

PRINCIPLES OF FIRE FIGHTING AND
DESCRIPTION AND USE OF EQUIPMENT AND APPARATUS

1. GENERAL

- 1.01 This section covers the principles of fire fighting and describes the construction and use of fire fighting equipment and apparatus.
- 1.02 The types of equipment and apparatus covered are:
- (A) Carbon Dioxide Type - Fire Extinguishers
 - (B) Water Type - Fire Extinguishers
 - (C) Foam Type - Fire Extinguishers
 - (D) Soda Acid Type - Fire Extinguishers
 - (E) Asbestos Gloves
 - (F) Tarpaulins
 - (G) Standpipe and Hose Systems
 - (H) Fire Shutters
- 1.03 Consideration should be given to the three basic lines of defense against fires when determining the proper equipment and method to use for fighting a central office fire. These lines of defense and the order in which they should be used are (1) fire extinguishers, (2) standpipe and hose, and (3) Fire Department.
- 1.04 Fire can be extinguished by two general methods. First, it can be extinguished by cooling the burning material to a temperature lower than that at which combustion occurs. Secondly, it can be extinguished by excluding the oxygen which is necessary to support combustion.
- 1.05 In the second method the condition must be maintained until the burned material has cooled sufficiently to prevent its rekindling upon removal of the oxygen excluding agent. Therefore, since oxygen ordinarily can not be permanently excluded from any material, the fundamental method of extinguishing fire is the cooling of the material below its kindling temperature.
- 1.06 Most extinguishing devices use both methods with one or the other predominating. The cooling effect predominates in extinguishing devices whose discharge is principally water. The smothering effect is prominent in devices such as the carbon dioxide gas extinguisher, foam type extinguisher, asbestos gloves, etc.
- 1.07 The cooling method can not be directly applied to fires in certain materials such as oils and greases. In these cases, it is necessary to smother the fire and allow the material to cool off itself.
- 1.08 The smothering method can not be applied successfully to fires which are too hot to permit the exclusion of oxygen long enough to allow the material to cool below the kindling temperature. The carbon dioxide extinguisher, for example, is not effective in fighting fires which have been burning long enough to produce a large mass of highly heated material.
- 1.09 Extinguishing agents in which the cooling effect predominates are best applied from the top down when used on telephone equipment fires. The liquid then will flow down onto the burning equipment and exert the maximum cooling effect. For other than telephone equipment fires, play the stream at the base of the flames and follow the flames with the stream.
- 1.10 Extinguishing agents such as carbon dioxide gas in which the smothering effect predominates are best applied from the bottom up. The gas is then drawn up around the burning material by the draft which the fire creates and thus smothers the fire.

2. DESCRIPTION AND USE

(A) Carbon Dioxide Type - Fire Extinguishers

- 2.01 Carbon dioxide type fire extinguishers are provided for fighting small fires which have just started or which have not gained appreciable headway, such as fires in wires, cables, switchboards, power boards, power plant apparatus, elevator machinery, and flammable liquids in certain locations.
- 2.02 There are two capacities of extinguishers most widely used in central offices, one containing about 10 pounds of carbon dioxide and the other, an older model, containing about 7-1/2 pounds.
- 2.03 Two types of 10-pound extinguishers are used, their principal difference being the method of operation. One type releases the gas by rotating a handwheel and the other by

SECTION 010-105-001

pressure on a trigger. The 10-pound trigger operated extinguisher supersedes the older hand-wheel type. Handwheel type extinguishers of 10-pound capacity have been furnished in two over-all weights differing by about 5 pounds. To readily identify these extinguishers, a yellow mark is furnished on the front of the cylinder of the lighter weight extinguisher. The trigger release extinguisher is about the same weight as the lighter of the two handwheel types.

2.04 Each extinguisher consists of a steel cylinder containing carbon dioxide under pressure which is discharged as a gas through a hose and a cone shaped nozzle when released. A general view of the 10-pound extinguisher having trigger release is shown in Fig. 1 and the 10-pound handwheel release unit is shown in Fig. 2.

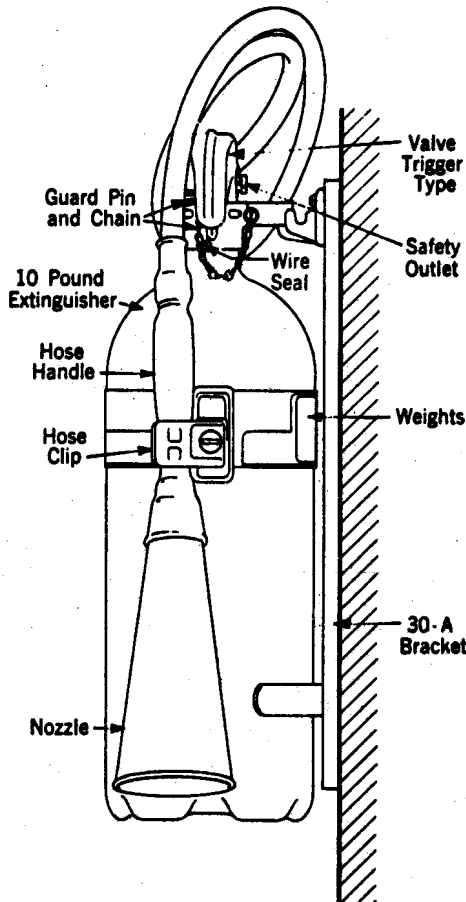

Fig. 1 - Carbon Dioxide Extinguisher - Newer Design

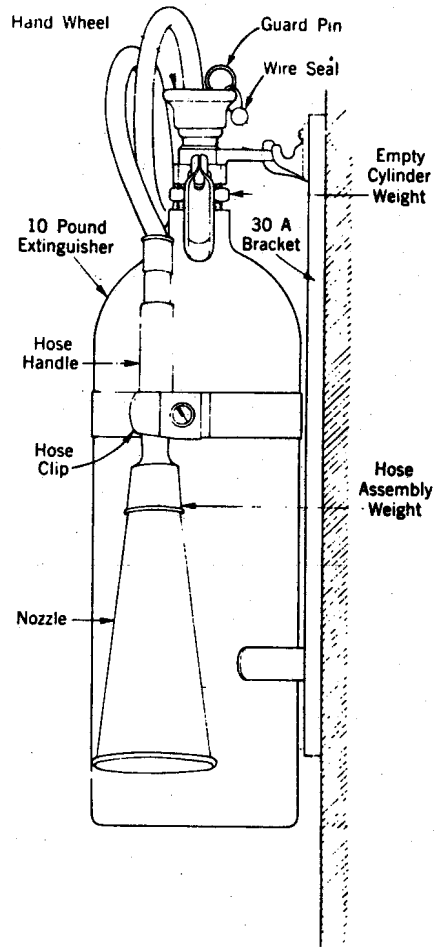

Fig. 2 - Carbon Dioxide Extinguisher - Former Design

2.05 The velocity of the gas emerging from the nozzle is quite low, therefore, the gas is most effective when the nozzle is held within 1 or 2 feet of the fire. The discharge for both the 10-pound and the 7-1/2-pound extinguishers continues for 40 to 45 seconds. The gas has no appreciable cooling effect in fighting fires, but extinguishes the fire by its smothering action.

2.06 The carbon dioxide when discharged is cooled to a very low temperature which results in the metal parts of the nozzle becoming intensely cold. Therefore, when discharging this type of extinguisher the nozzle should be held by the hose just back of the nozzle so that the hand does not come in contact with the metal parts of the nozzle. At the same time solidified gas in the form of "snow" appears in the gas cloud and collects on the floor and

other surfaces for a few minutes until it evaporates. This "snow" is extremely cold and should not be handled as frostbite may result.

Caution: Although the gas is not poisonous, care should be taken to avoid breathing the vapors or gases liberated by the extinguisher, especially when it is used in un-ventilated places.

2.07 Valve - 10-Pound Trigger Release: Internally this valve has a main and an auxiliary valve seat. Operation of the trigger initially opens the auxiliary valve which admits full gas pressure to both sides of the main valve seat. Further pressure of the trigger opens the main valve with little effort. When not in use both valves are held closed not only by spring pressure but by full pressure of the gas within the cylinder. The trigger can be latched in the open position or can be released at will to stop the flow of gas, thereby permitting temporary conservation of the gas for use on any rekindling action which may occur after the fire has apparently been extinguished. To prevent inadvertent operation, the trigger is locked in the inoperative position by a pin having a chain attachment to the body of the extinguisher. The pin must be withdrawn to permit operation of the trigger. A wire seal is provided which is broken by operating the trigger, thus furnishing a visible means for determining whether the extinguisher has been previously operated.

2.08 Valve - 10-Pound Handwheel Release: This valve also can be closed after it has been opened, thereby permitting temporary conservation of the gas. The seal is, however, only temporary and is not sufficiently tight to retain the gas for more than a short time. The valve is provided with a guard pin which prevents accidental operation of the handwheel by fixing it in position. A wire seal gives a visual indication of whether the guard pin and handwheel have been tampered with. To use the extinguisher, it is first necessary to withdraw the guard pin which breaks the wire seal.

2.09 Valve - 7-1/2 Pounds: The valve on the 7-1/2-pound extinguisher cannot be closed once it has been opened. A handwheel guard is available for this extinguisher to minimize the possibility of tampering with the handwheel and discharging the extinguisher while on the mounting bracket. This guard is shown in Fig. 3 and should be provided only in cases where tampering might be expected.

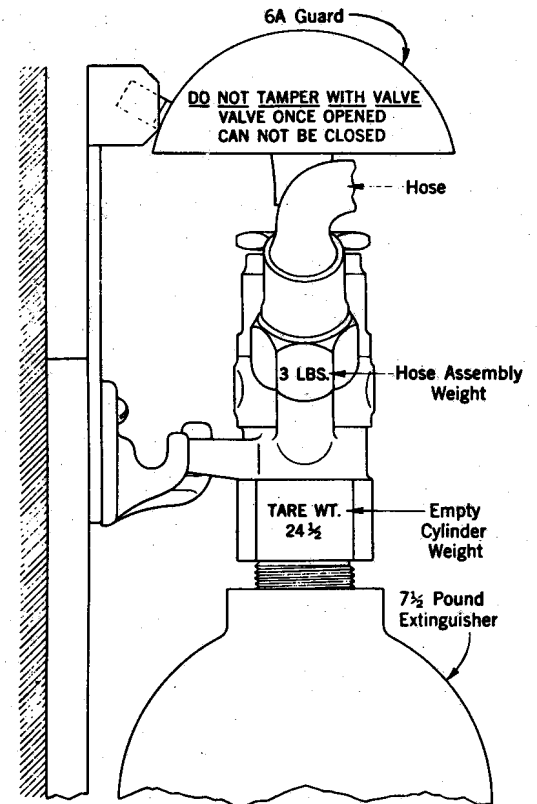

Fig. 3 - Handwheel Guard

2.10 Safety Cap - 7-1/2 Pounds: A safety cap is provided on the 7-1/2-pound extinguisher for use during shipment when the hose is not in place on the extinguisher. It is important that during shipment and storage this cap be in place, since otherwise if the extinguisher is accidentally discharged there is considerable recoil. The cap also provides mechanical protection for the threads of the valve outlet. When not on the valve outlet, the cap is normally attached to a bushing on the extinguisher handle. The 10-pound extinguishers are so designed that separate safety caps are not required.

2.11 Carbon dioxide type extinguishers may be provided in both heated and unheated spaces occupied by telephone equipment.

2.12 The carbon dioxide gas is subject to a rapid rise in pressure where temperatures above normal are experienced. It is, therefore, desirable to locate these extinguishers away from hot surfaces and out of the direct

SECTION 010-105-001

rays of the sun. In general the clearance between extinguishers and radiators or uncovered heating pipes will be at least 2 feet. This distance may be reduced to 6 inches in the case of covered pipes.

(B) Water Type - Fire Extinguishers

2.13 The water type extinguisher is used on fires in telephone equipment which have made some headway and which are beyond the scope of the carbon dioxide type due to insufficient range of discharge or to lack of cooling action of the gas on large masses of burning material. The water type is not suitable for use on fires involving flammable liquids, oils, greases, or live electrical equipment, such as power boards, power plant apparatus, or elevator machinery.

2.14 The water type extinguisher replaces the soda acid extinguisher in central office equipment areas and supplements the carbon dioxide extinguisher.

2.15 The extinguisher consists of a lead lined copper tank of about 2-1/2 gallons capacity and uses plain water which is expelled by the expansion of carbon dioxide from a small metal cartridge located within the tank. The cartridge is attached to the underside of the extinguisher cap and is removable with the cap. A grooved puncturing pin attached to a plunger extends through the extinguisher cap and is directly above and at right angles to a disc in the top of the cartridge. The details of the newer extinguisher are shown in Fig. 4.

2.16 A "U" shaped hinged guard is placed over the outside end of the plunger to prevent accidental puncturing of the cartridge disc. When the extinguisher is to be discharged this guard is pushed back and becomes fixed in the open position.

2.17 To discharge the extinguisher, the safety guard over the plunger is pushed aside and the tank turned bottom up and bumped against the floor. This causes the plunger to be forced in and the grooved pin to puncture the disc in the cartridge and releases the carbon dioxide into the extinguisher tank. The water in the tank is expelled with sufficient force to throw an effective stream some 30 feet and continues for about 50 seconds, after which gas is emitted for a few seconds. The discharge of liquid ceases when the extinguisher is turned right side up, but the gas continues to escape and can not be stopped until it is exhausted. A new cartridge must be inserted and the tank refilled before the extinguisher can be used again.

2.18 In case the guard is not pushed back when the extinguisher is to be used, the plunger will not be obstructed since the guard is of metal, light enough to collapse when crushed to the floor under the weight of the extinguisher.

2.19 A rubber jacket is provided over the cartridge for the purpose of preventing possible electrolytic corrosion.

2.20 All cartridges are supplied with a screw type safety cap which should be left in place until just before weighing the cartridge prior to its installation in an extinguisher.

2.21 The carbon dioxide which is held under pressure in the cartridge is subject to a rapid rise in pressure where temperatures above normal are experienced. It is desirable, therefore, to locate these extinguishers away from hot surfaces and out of the direct rays of the sun. In general the clearance between extinguishers and radiators or uncovered heating pipes will be at least 2 feet. This distance may be reduced to 6 inches in the case of covered pipes.

2.22 Water type extinguishers are subject to freezing and, therefore, are not located in areas where freezing temperatures may be encountered.

(C) Foam Type - Fire Extinguishers

2.23 The foam type fire extinguisher is one of the approved types to be used on fires in locations which involve flammable liquids, such as oil, grease, kitchen fats, and gasoline. It is not suitable for use on fires involving central office equipment or live electrical equipment, such as power boards, power plant apparatus, or elevator machinery. It is suitable for use, however, on grease or kitchen fat fires on electrical heating elements whether or not the power can be turned off.

2.24 The extinguisher consists of a lead lined copper tank of about 2-1/2 gallons capacity, using water mixed with sodium bicarbonate and a foam-producing agent and an inner container holding a solution of aluminum sulphate. The liquid is expelled by inverting the tank, causing the aluminum sulphate to be mixed with the sodium bicarbonate solution resulting in a chemical action which produces foam and generates pressure that forces the liquid out of the hose with sufficient force to throw an effective stream about 30 feet. This discharge starts almost immediately after the tank is inverted and continues for about 50 seconds until all the liquid is gone. The discharge of foam

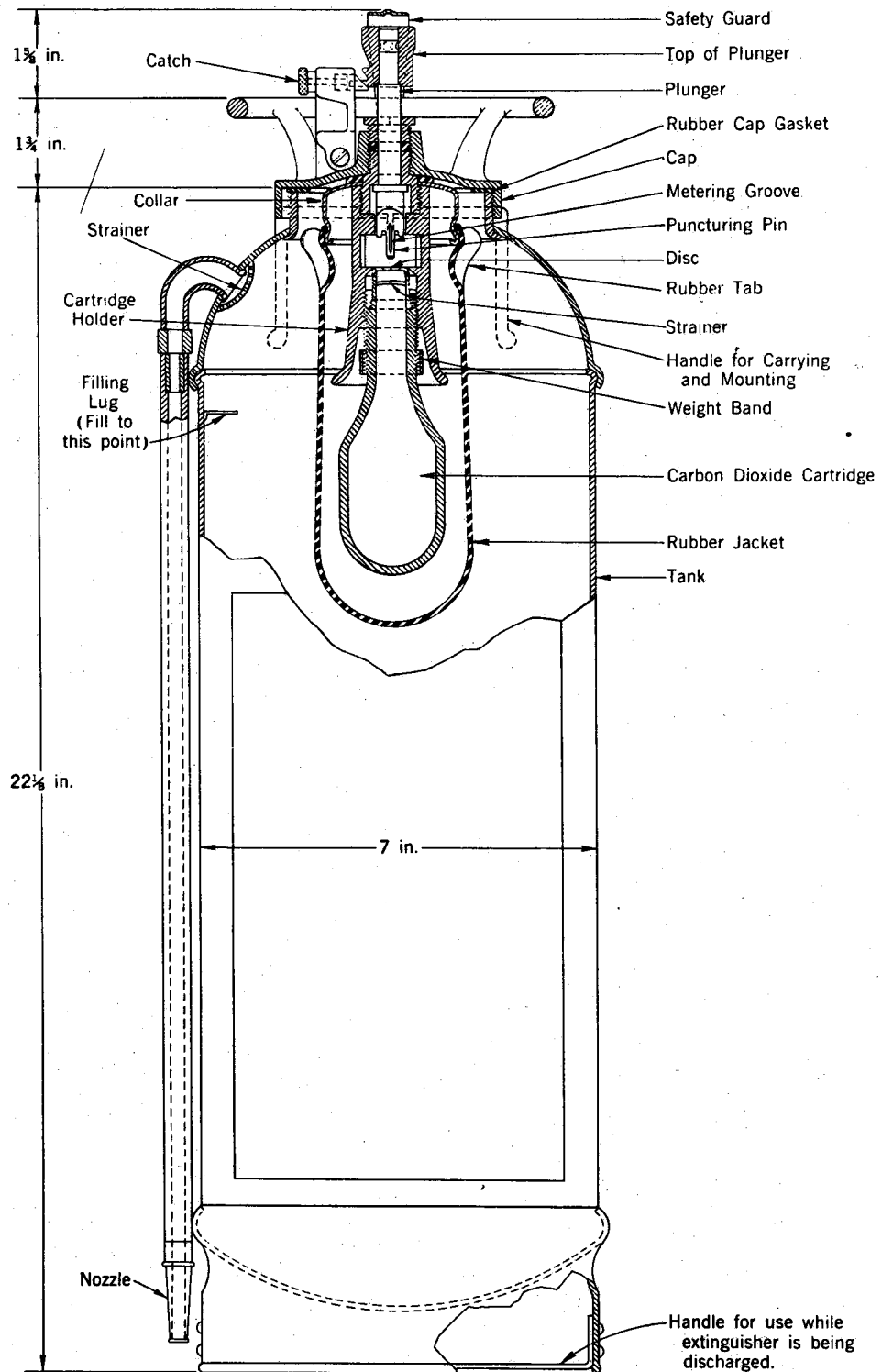

Fig. 4 - Water Extinguisher - Newer Design

slows up when the extinguisher is turned right side up, but a certain amount continues to escape and can not be stopped until the chemical action has been completed. The extinguisher must be recharged before it can be used again. The details of a typical extinguisher are shown in Fig. 5.

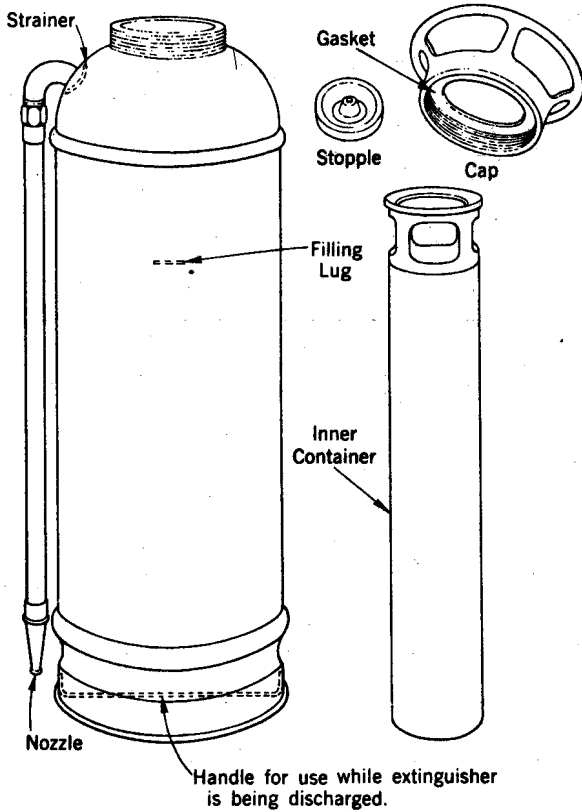

Fig. 5 - Foam Extinguisher

2.25 Foam extinguishers are subject to freezing and their action becomes sluggish at temperatures of 40° F or lower and, therefore, are not located in areas where the temperature may be lower than this figure.

(D) Soda Acid Type - Fire Extinguishers

2.26 The soda acid type fire extinguisher is used on paper, wood, and trash fires. The soda acid extinguisher is not suitable for use on fires involving telephone equipment, flammable liquids, oils, greases, or live electrical equipment, such as power boards, power plant apparatus, or elevator machinery.

2.27 Since the chemicals used in the soda acid extinguisher may cause considerable damage to telephone equipment, it is replaced by the water type extinguisher in central office equipment areas.

2.28 The extinguisher consists of a lead lined copper tank of about 2-1/2 gallons capacity, containing water mixed with sodium bicarbonate and a bottle half full of sulphuric acid. The liquid is expelled by inverting the tank causing sulphuric acid to be mixed with the sodium bicarbonate solution resulting in a chemical action generating carbon dioxide gas, the pressure of which forces the liquid out of the hose with sufficient force to throw an effective stream about 30 feet. This discharge starts almost immediately after the tank is inverted and continues for about 50 seconds until all the liquid is gone. The discharge of liquid ceases when the extinguisher is turned right side up, but the gas continues to escape and can not be stopped until the chemical action has been completed. The extinguisher must be recharged before it can be used again. The details of a typical extinguisher are shown in Fig. 6.

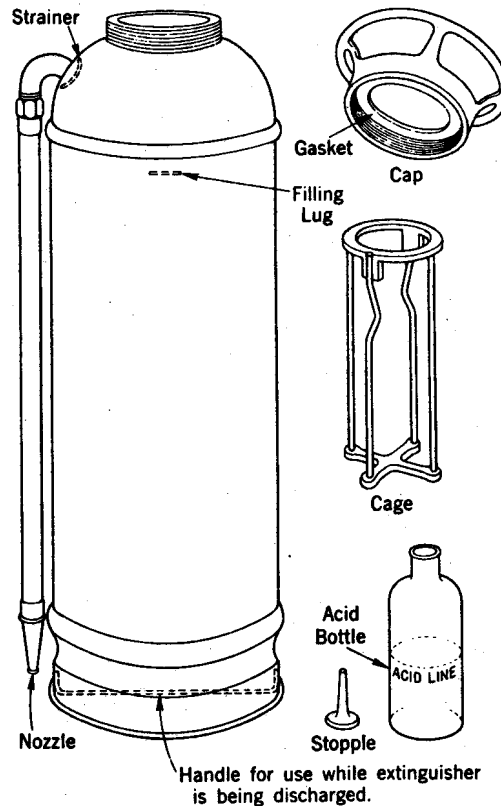

Fig. 6 - Soda Acid Extinguisher

2.29 Soda acid extinguishers are subject to freezing and their action becomes sluggish at temperatures of 40° F or lower and, therefore, are not located in areas where the temperature may be lower than this figure.

(E) Asbestos Gloves

2.30 Asbestos gloves are provided for extinguishing small fires in telephone equipment and for snuffing out small quantities of glowing embers after the flames have been smothered.

2.31 The glove consists of a 20-inch asbestos gauntlet having three fingers and two thumbs. It is large enough for any hand and arm, and having two thumbs it can be used on either hand without loss of time in arranging for proper fit (see Fig. 7).

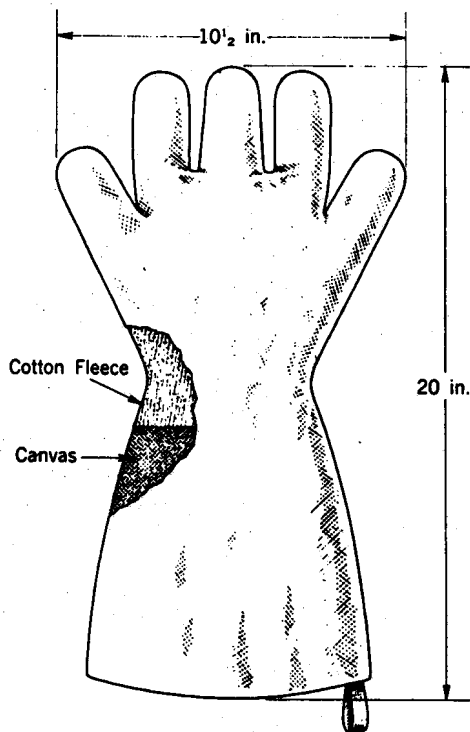

Fig. 7 - Asbestos Glove

2.32 Two gloves comprise a set and are kept in a metal container having a metal ring attached to a hinged cover on the bottom, which is pulled down in order to grasp the gloves. The glove container is designed for attachment to the mounting bracket of the carbon dioxide extinguisher and is perforated at four points so that it may be seen whether the gloves are in place.

(F) Tarpaulins

2.33 Tarpaulins are used to protect telephone equipment and in some cases other important apparatus or records from possible damage from water due to roof or plumbing leaks, or other emergency conditions.

2.34 The tarpaulins provided are generally of the portable type. The practice of furnishing stationary tarpaulins has been discontinued except in specific cases, but existing installations should be continued in service until replacement is necessary.

2.35 Portable tarpaulins are made of nylon or cotton twill cloth and are approximately 5 feet 10 inches by 12 feet in size with a 1-inch hem around the four sides to reinforce the edges. Eyelets are placed in the hem for the purpose of securing the tarpaulin in place when in use. The waterproof coating consists of two coats of polyvinyl chloride on each side with an additional top coating on one side of the type made from cotton twill cloth. Tarpaulins of these materials are comparatively light and reasonably pliable, permitting safe use with delicate telephone apparatus. Six tie cords, 2 feet 9 inches long, are furnished with each tarpaulin and they are stored between the folds when the tarpaulin is in the container.

(G) Standpipe and Hose Systems

2.36 The description of standpipe and hose systems covered in this section are based in general on the standards of the National Board of Fire Underwriters and of the National Fire Protection Association. Deviations from this would be where local or state regulations require higher degrees of protection than those covered in this section.

2.37 Standpipe and hose equipment is a complete and separate system of water piping connected to one or more water supplies designated for immediate use on interior fires should they reach such proportions that they can not be handled successfully with fire extinguishers. Hose lines are not used on small incipient fires (controllable by extinguishers) or on live electrical equipment, such as power boards, power plant apparatus, or elevator machinery.

2.38 Standpipe systems are provided with 1-1/2-inch hose lines for use by Telephone Company personnel as a first-aid measure against fires, and in addition, larger buildings are provided with 2-1/2-inch connections for use by the Fire Department.

2.39 First-aid hose stations and control valves are wall mounted or inside of a recessed wall cabinet with a glass door and are generally located near the standpipe in areas to be protected, but not in stairways or fire towers. Each 1-1/2-inch hose station inside the building, regardless of the standpipe size, is equipped with not more than 75 feet of unlined linen hose.

SECTION 010-105-001

2.40 Where hose stations are provided on the roof, they are for use by Telephone Company personnel and the Fire Department on roof fires and adjacent property fires menacing the telephone building. These hoses are 2-1/2 inches in size and of sufficient length to reach all edges of the roof.

2.41 Care should be taken to avoid unnecessary wetting of hoses, as they are made of linen and when wet are liable to rot. Therefore, after using a fire hose it is important that it be thoroughly dried before replacing it on the rack for future use. The danger of hoses becoming wet while on the rack can be avoided by placing them entirely above the outlet (coiled upward instead of downward) with a pin hole on the lower side of the nipple for slight possible drainage.

2.42 A fire hose should not be used under any circumstances for other than fire purposes. Violation of this rule may result in the hose being misplaced, defective, or useless at the time of a fire.

2.43 The primary water supply for the standpipe system is generally obtained from the street water main which can provide water under continuous and at usually adequate pressure and volume. This supply is capable of instantly furnishing water for one or two 1-1/2-inch hoses first operated. The supply will normally be capable of providing 70 gallons per minute per hose line for approximately 30 minutes at a pressure of 25 pounds per square inch to the highest 1-1/2-inch hose outlet in the building. In certain areas, however, the pressure in the street main may be inadequate for providing good hose streams. In such cases, an automatic or manually operated fire pump is installed for boosting the pressure. The secondary water supply, when provided, is required to furnish water under strong pressure for extended periods of time and is normally brought into play by furnishing 2-1/2-inch hose streams for use by the Fire Department in coping with larger fires.

2.44 In large, high-storied buildings, there are generally two water supplies provided for standpipe and hose equipment and they are referred to as the primary and secondary sources. The operating function of each supply is explained in Paragraph 2.43. A typical and most frequent example of two separate but interconnected water supplies would be a 5000-gallon gravity roof tank and/or a 4500-gallon pressure tank (water held under controlled air pressure) constituting one supply with the second supply being a separate water line connecting with the

street main and used only for fighting fires. A permanently installed building fire pump is usually necessary in the pipe line of the second supply for providing water at strong pressures for possible use by the Fire Department when operating 2-1/2-inch hose streams at the higher floors of the building.

2.45 As a precautionary measure, upon arrival, the Fire Department will usually connect their pumpers to the standpipe system's siamese connection, which is normally located on the street front wall. Under unusually severe fire conditions these pumpers, which obtain their water supply from fire hydrants, discharge additional water into the building standpipe system at strong pressures for serving 2-1/2-inch Fire Department hose streams.

(H) Fire Shutters

2.46 Fire shutters are mounted at window openings so that when closed they will protect the windows from external fires. Fire shutters are usually mounted on the exterior unless appearance is a factor and then they are mounted on the interior. There are two types of fire shutters used on telephone buildings, the "Automatic Rolling Fire Shutter" and the "Manually Operated Fire Shutter."

2.47 The automatic rolling fire shutter (see Fig. 8) consists of an interlocking steel curtain which coils on a steel tube in a housing above the window opening. The shutter when raised or dropped travels in vertical steel guides which may be secured to the window frame or the face of the window opening.

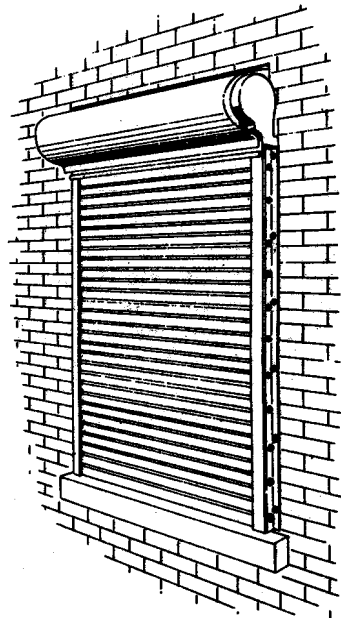

Fig. 8 - Automatic Rolling Fire Shutter

2.48 The fire shutter is held in the open position by a locking device controlled by a fusible link. This fusible link melts at a comparatively low temperature, automatically releasing the lock and dropping the shutter to close the window opening.

2.49 Manually operated fire shutters (see Figs. 9 and 10) sometimes known as the swinging type are of metal construction. Each shutter is equipped with hinges and a suitable latch arrangement to secure it in the closed position.

2.50 In the event of fire, the shutters are manually placed in their fully closed position and the latch arrangement set to hold them firmly in place.

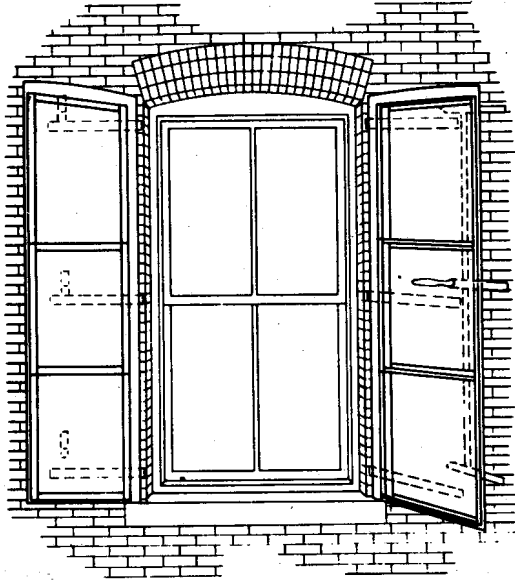

Fig. 9 - Manually Operated Fire Shutter - Open

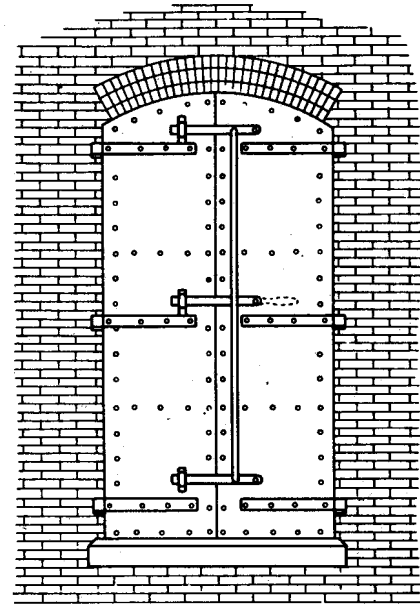

Fig. 10 - Manually Operated Fire Shutter - Closed