

KS-19739 L1 AMPLIFIER

TESTS

	CONTENTS	PAGE
1.	GENERAL	1
2.	TEST INTERVALS	1
3.	APPARATUS REQUIRED	1
4.	PREPARATION	1
5.	GAIN-FREQUENCY TEST	2
6.	POWER OUTPUT TEST	2
7.	OUTPUT REGULATION TEST	3
8.	NOISE TEST	3

1. GENERAL

1.01 This section outlines the transmission tests for the KS-19739 L1 amplifier as a unit. The KS-19221 L1 plug-in amplifier (included in the KS-19739 L1 amplifier unit) may be removed and tested separately, when necessary, in accordance with Section 024-181-100. The KS-19739 L1 amplifier may be used in systems requiring up to 4 watts output. A schematic diagram of the amplifier is shown in Fig. 1.

1.02 This section is reissued to change test equipment and to incorporate changes in the schematic diagram of the KS-19739 L1 amplifier. This reissue does not affect the Equipment Test List.

1.03 Tests other than those described in this section may be required as a result of trouble reports. The particular tests required in such cases must be determined by the nature of the reported trouble.

2. TEST INTERVALS

2.01 The tests outlined in this section should be performed every 3 months. Each test should

be performed before the amplifier is placed in service.

3. APPARATUS REQUIRED

3.01 The following apparatus is required for use in performing these tests. If the specified equipment is not available, a substitute which is electrically equivalent may be used.

1—Hewlett-Packard Model 200 CD Signal Generator or KS-19260 Oscillator

1—Tektronic Model 453 Oscilloscope or equivalent

2—Hewlett Packard Model 400 Series AC Voltmeter or equivalent

1—600-Ohm Resistor, ± 5 percent 5-watt noninductive

—Test cords and clips as required

3.02 When substitute test equipment is used, observe caution in the selection of such equipment. If an attenuator or pad circuit is necessary, because of the selection of substitute equipment, it should be capable of dissipating at least 4 watts of power and constructed of noninductive devices.

4. PREPARATION

4.01 All ac-operated test equipment should be allowed to warm up sufficiently before beginning any tests. This is important since it has a bearing on the stability of the equipment and accuracy of the tests. All test equipment should be calibrated before beginning the tests.

4.02 The amplifier should be removed from service before testing. The signal input and the amplifier output should be disconnected, or opened, at the most convenient point.

Note: Unless absolutely necessary, wire-wrap terminations should *not* be disturbed.

4.03 A good ground should be connected to terminal 26 of TB1 to reduce the possibility of induced noise.

4.04 Refer to the manufacturer's instructions and/or the appropriate BSPs for proper operation of test equipment.

4.05 Connect the oscilloscope to the signal generator output, and observe the sine wave to ensure that no distortion exists in the oscillator output.

5. GAIN-FREQUENCY TEST

5.01 The test setup for this test is shown in Fig. 2. This test is conducted with the amplifier set at maximum gain. The test is performed as follows:

STEP	PROCEDURE
1	Carry out the preparations described in Part 4.
2	Connect the 600-ohm, 5-watt resistor and model 400 voltmeter across the amplifier output terminals 37 and 38. See Fig. 2.
3	Connect model 400 voltmeter and the 600-ohm balanced output signal generator across amplifier input terminals 11 and 12. Connect the shields of the test cables to terminal 13.
4	Turn the amplifier gain control R6 to its maximum clockwise position, and leave it there throughout this test.
5	Set the signal generator to 1000 Hz, and adjust the oscillator output to give an indication of 24.5 volts (1 watt) on the meter connected across the 600-ohm amplifier output termination.
6	Note the meter indications, in dB, of both meters. <i>Requirement:</i> The 1000-Hz gain (difference in meter indications plus attenuation inserted) shall be 62 ± 2 dB.
7	Repeat Steps 5 and 6 with the oscillator set on 150 Hz and 8000 Hz. <i>Requirement:</i> The 150-Hz gain and the 8000-Hz gain shall not differ from the 1000-Hz gain, previously measured, by more than $+0, -3$ dB.

6. POWER OUTPUT TEST

amplifier set at maximum gain. The test is performed as follows:

6.01 The test setup for this test is shown in Fig. 2. This test is conducted with the

STEP	PROCEDURE
1	With all the test equipment connected as in the previous test (except the voltmeter across the input terminals), connect an oscilloscope across the 600-ohm, 5-watt terminating resistor and the model 400 voltmeter. See Fig. 2.

STEP	PROCEDURE
2	Set the oscillator to 1000 Hz.
3	Adjust the oscillator output to give an indication of 49 volts (4 watts) on the model 400 voltmeter connected across the 600-ohm load resistor.
4	Observe the oscilloscope.
Requirement: There shall be no flattening of the peaks observed on the oscilloscope.	

7. OUTPUT REGULATION TEST

amplifier set at maximum gain. The test is performed as follows:

7.01 The test setup for this test is shown in Fig. 2. This test is conducted with the

STEP	PROCEDURE
1	Connect the test equipment as described in the previous test. See Fig. 2.
2	Adjust the oscillator to give an indication at 1000 Hz of 49.0 volts (4 watts) into the 600-ohm load.
3	Observe the oscilloscope.
Requirement: The oscilloscope shall show a clean sine wave (no distortion).	
4	Observe the voltmeter reading in dB.
5	Remove the 600-ohm, 5-watt load resistor.
Requirement 1: The amplifier output voltage shall not increase more than 3 dB when the load is removed.	
Requirement 2: The oscilloscope shall show a clean sine wave.	
6	Disconnect the test equipment.

8. NOISE TEST

to reduce the possibility of induction noise. The test is performed as follows:

8.01 The test setup for this test is shown in Fig. 3. The amplifier should be grounded

STEP

PROCEDURE

- 1 Terminate the amplifier with the 600-ohm, 5-watt resistor and the model 400 voltmeter connected across terminals 37 and 38 of TB1. See Fig. 3.
- 2 Connect a 600-ohm ± 5 percent resistor across the amplifier input terminals 11 and 12.
- 3 Adjust the amplifier gain control to its maximum clockwise position.
- 4 Observe the voltmeter.

Requirement: The reading of the voltmeter shall not exceed 0.015 volt.

- 5 Remove the test equipment, and restore the amplifier to service if all requirements are met.

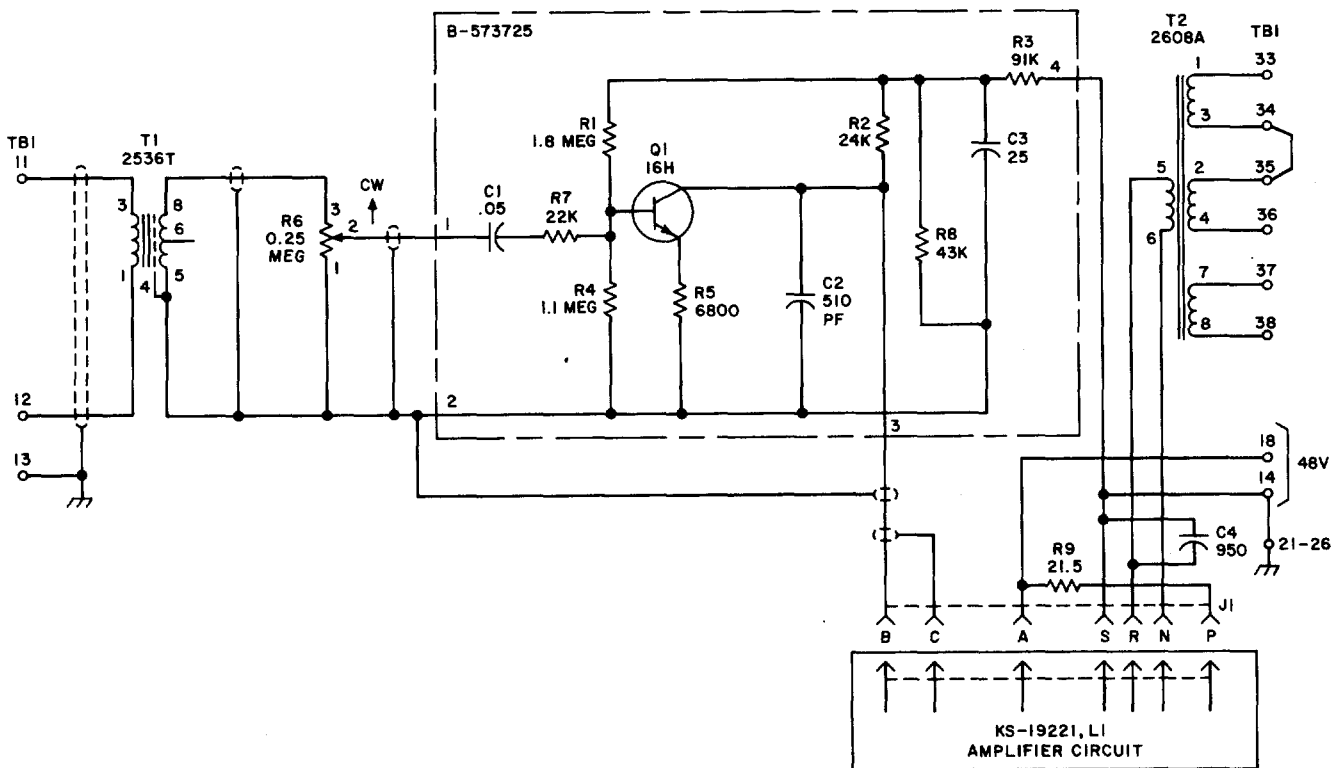

Fig. 1—KS-19739 L1 Amplifier, Schematic Diagram

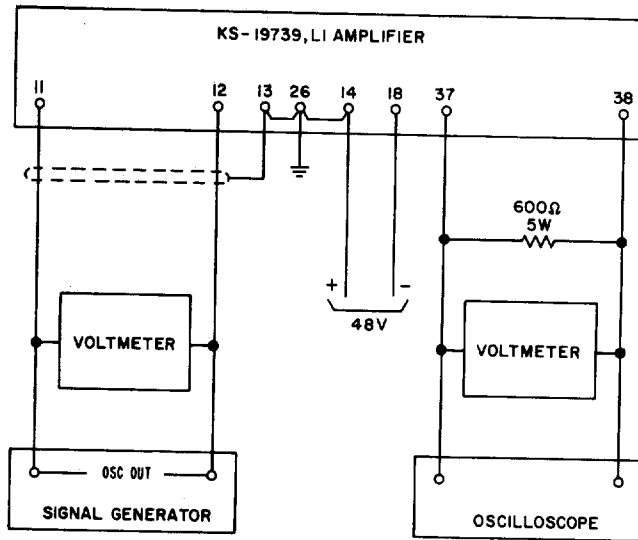

Fig. 2—Test Setup for Gain-Frequency, Power Output, and Output Regulation Tests

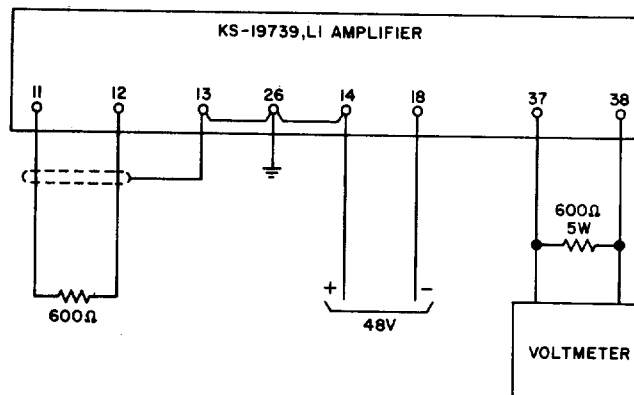

Fig. 3—Test Setup for Noise Test