

RESISTOR AND ACROSS-THE-LINE TYPE STARTERS

ALLEN-BRADLEY COMPANY AND WARD LEONARD COMPANY

REQUIREMENTS AND ADJUSTING PROCEDURES

1. GENERAL

1.01 This section covers the following starters. Some have KS designations, the remainder have only the manufacturer's code number.

Allen-Bradley		Ward Leonard	
KS-5309	KS-15584	K-40796	K-40908
		K-40797	K-40910
		K-40798	K-40923
Ward Leonard		K-40799	K-40947
KS-5505	KS-5543	K-40807	K-40985
	KS-5770		
		K-40808	K-40986
KS-15841	KS-15861	K-40809	K-40987
		K-40855	K-40988
		K-40907	

1.02 This section is reissued to:

- Incorporate the information contained in Addendum 026-356-701, Issue 1
- Revise paragraph 3.02(4).

1.03 The starters covered in this section consist mainly of ac contactors of various forms in combination with overload and control relays of various types. For maintenance of the control relays, refer to Section 040-811-701.

1.04 Reference shall be made to Section 020-010-711 covering general requirements and definitions for additional information necessary for the proper application of the requirements listed herein.

1.05 *Phi* (ϕ): Requirements are marked with a phi when they are not required to be checked before turnover.

1.06 *Asterisk* (*): Requirements are marked with an asterisk when to check for them would necessitate dismantling or dismounting of apparatus, or would affect the adjustment involved, or other adjustments. No check need be made for these requirements unless the apparatus or part is made

accessible for other reasons, or its performance indicates that such a check is advisable.

1.07 For the purpose of this section, whether contacts are *normally open* (NO) or *normally closed* (NC) depends on the position of these contacts when no operating current is flowing in the coil and not on the position the contact may normally be in for a particular application.

1.08 A contactor is said to *release* when the armature or plunger has moved sufficiently for normally open contacts to open and normally closed contacts to close with reliable contact.

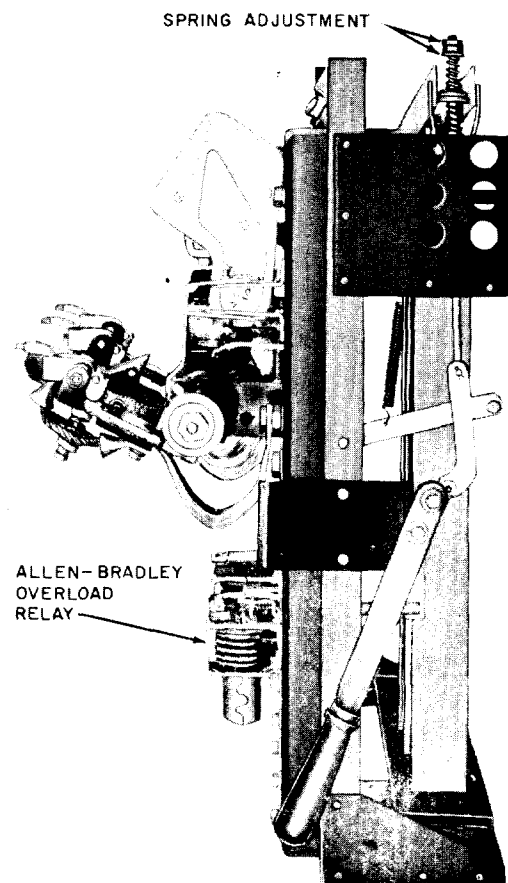

Fig. 1—KS-5309 Starter

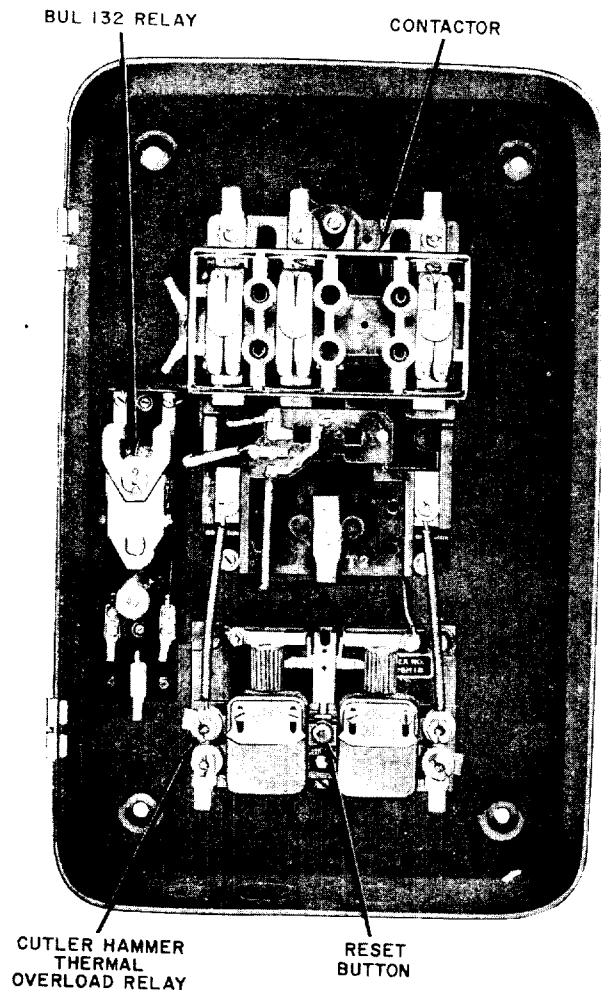

Fig. 2—KS-5505 Starter

1.09 A contactor is said to *operate* when the armature or plunger has moved sufficiently for normally closed contacts to open and normally open contacts to close with reliable contact.

Caution: Before performing any work on the starter or checking requirements other

than electrical requirements, disconnect the starter from the power supply. If the starter operates in an automatic control circuit, the automatic control should be made inoperative as described in the appropriate section covering the apparatus.

1.10 Where the construction is such that adjustments or other procedures are not practicable, failure to operate satisfactorily should be corrected by replacing the appropriate parts or the entire unit.

1.11 Orders for parts needed for replacement should give the nameplate data of the starter, including manufacturer's name, type, or bulletin number, and serial number, KS and list numbers if any, together with a description of the part.

2. REQUIREMENTS

2.01 Mounting: The mounting bolts and the fasteners which hold the component parts together shall be secure.

Gauge by feel.

Caution: Do not touch or short-circuit live terminals or parts.

2.02 Cleaning Contacts and Removing Buildups: Contacts shall be clean and free from buildups which might interfere with reliable contact.

Gauge by eye.

2.03 Contact Alignment: Each pair of contacts shall be aligned so that, when the contactor is operated, the outer edge of one contact does not overlap the outer edge of the other by more than 1/8 of its diameter or width at turnover, and not more than 1/4 during life. In no case shall the overlap exceed 1/8 inch.

Gauge by eye.

2.04 Contact Sequence

(a) All main contacts of multipole contactors shall make or break approximately at the same time.

Gauge by eye.

(b) Auxiliary NO contacts, where present, shall make just before the main contacts make.

Gauge by eye or use an 81A test set (buzzer) as necessary.

2.05 Contact Separation

(a) Contact separation shall be as specified in the circuit requirements table.

Use the R-8550 scale.

Ward Leonard Equipment

(b) Unless otherwise specified, the contact separation shall be

CONTACTORS (main contacts)	MIN (inches)
K-42506 and K-42814	3/4
Bulletin 1901, Size 2	9/16
Bulletin 4401, Size 4	3/4

Use the R-8550 scale.

(c) If the contact separation is not specified, like contacts on the same contactor shall have approximately the same separation. In no case shall the gap be so small that the arc formed at the opening of the circuit is not extinguished promptly.

Gauge by eye.

2.06 Contact Pressure and Follow

(a) Contact pressure, as measured with the contacts closed, shall be as specified in the circuit requirements table.

(b) When not specified in the circuit requirements table, the minimum contact pressure shall be as specified in the following table.

Ward Leonard

CONTACTORS	LBS	MINIMUM	
		OZS	GRAMS
K-42506	5	8	2500
K-42814	2	0	925
Bulletin 1901, Size 2 Main Contacts	1	12	800
Bulletin 4401, Size 4 Main Contacts	5	8	2500

Use spring balance or gram gauge, as applicable.

(c) In general, there is an additional movement of the operating mechanism after the contacts touch. This usually results in the sliding of one contact on the other or in an increase in the contact pressure and is known as follow. It is necessary that the follow be checked where, due to the construction, contact pressure cannot be measured, or where specific values of contact pressure are not available. In such cases, contact follow shall be as specified in the following table.

Allen-Bradley Contactors	MIN (inches)
Bulletin 702	1/16

Ward Leonard Starters

KS-5770, KS-15841, and KS-15861	1/16
---------------------------------	------

Gauge by eye and feel.

2.07 Overload Relays

(a) **Adjustable Types**

φ(1) Overload relays, where present and adjustable, shall be adjusted to operate at a value not exceeding 115 percent of the full-load running current given on the motor nameplate.

* (2) With 200 percent of the relay current rating as given on the relay nameplate multiplied by the percentage settings as read on the scale plate of the relay flowing in the heater coil of the overload relay, the relay shall operate within 5 minutes.

*(b) **Nonadjustable Types:** With 250 percent of the full-load current of the motor as given on the motor nameplate flowing in the heater coil of the overload relay, the relay shall operate within 5 minutes.

φ(c) The operate requirements of all overload relays shall be checked annually.

2.08 KS-5309 Starter

(a) The starter shall be capable of starting and smoothly accelerating its associated motor.

Gauge by sound.

2.09 Electrical Requirements

(a) The contactor shall meet the electrical requirements specified in the circuit requirements table or other job information.

(b) Where electrical requirements are not specified in the circuit requirements table, operation of the contactor shall be checked at any voltage available within the voltage range on the relay nameplate. Where a specific value of voltage is given, the range shall be taken as ±10 percent.

(c) Check of electrical requirements may be at the temperature at which the relay is found, unless H (hot) or C (cold) is specified in the circuit requirements table.

Note: Where electrical requirements are not specified in the circuit requirements table or other job information, normal operation of the contactor is considered a satisfactory check, as indicated by (b) and (c), and this would also apply where no nameplate range or other operate values are available.

(d) Where H is specified in the circuit requirements table without heating instructions, the operating coil shall be energized for at least 1 hour prior to the test.

(e) Where C is specified in the circuit requirements table without cooling instructions, the operating coil shall be de-energized for at least 2 hours prior to the test.

*2.10 **Temperature:** The temperature rises of the various parts above an ambient

temperature between the limits of 10°C and 40°C shall not exceed the following values.

	MAXIMUM RISE ABOVE AMBIENT
Operating Coils	
Class A insulation	65 C (149 F)
Class H insulation	85 C (185 F)
Contacts (measured at the terminals for contactors)	75 C (167 F)
Resistors	250 C (482 F)

Use a thermometer.

If the temperature is thought to be excessive, check as follows. Hold the bulb of the thermometer against the hottest spot in question, covering the part of the bulb not in contact with the part being measured by a pad of asbestos. Observe the highest temperature indicated after it has stabilized.

Caution: Various parts reach temperatures at which it is dangerous to touch them.

3. ADJUSTING PROCEDURES

3.001 List of Tools, Gauges, Materials, and Test Apparatus

CODE OR SPEC NO.	DESCRIPTION
TOOLS	
373D	Contact Burnisher Holder
374A	Burnisher Blade
KS-2662	File
KS-6320	Orange Stick
KS-14208 (2 reqd)	Brush
R-1102	Fiber Spudger
R-1542	6-Inch Single-End Adjustable Wrench
—	P Long-Nose Pliers

CODE OR SPEC NO.	DESCRIPTION	CODE OR SPEC NO.	DESCRIPTION
TOOLS		TEST APPARATUS	
—	3-Inch C Screwdriver		230-volt input, type V-5HMT, General Radio Co, or equivalent)
—	4-Inch E Screwdriver	—	Fuse, 3 Amperes, 250 Volts
—	5-Inch E Screwdriver		
GAUGES		3.01 Mounting (Reqt 2.01)	
79B	0-1000 Gram Push-Pull Tension Gauge	(1) Tighten loose mounting screws and terminal nuts.	
79F	0-6000 Gram Push-Pull Tension Gauge	3.02 Cleaning Contacts and Removing Buildups (Reqt 2.02)	
R-2771	0- to 6-Pound Spring Balance	(1) General	
R-8550	6-Inch Steel Scale	(a) Before cleaning contacts or removing buildups, disconnect the power supply from the contacts. (Refer to 1.10.)	
—	−10° to +400 C Thermometer, Fisher Scientific Co No. 14-985	Caution: Be sure to disconnect the power supply before removing the arc hood covers of the contactors. Never operate starters with covers removed.	
—	Voltmeter, AC, Weston Model No. 528, Ranges 300-150	(b) Silver contacts of the contactors and relays must be replaced before the silver is completely gone. Do not file or use sandpaper or abrasive cloth on the contacts as it only results in a loss of silver and a reduction of life. Clean as in (2) or smooth with a burnisher as in (3). If buildups are excessive, the contacts should be replaced.	
—	Ammeter, AC, Weston Model No. 528, Range 50 Amperes	(c) Replace contacts which are badly worn. When replacing worn movable contacts of a control relay, or elsewhere when necessitated by the construction, install a complete contact spring.	
—	Ammeter, AC, Weston Model No. 528, Range 1 Ampere	(2) Cleaning Contacts: To remove dirt and gummy substance, clean the contacts with ♦KS-19578 L1 trichloroethane♦ as covered in (a) and (b) and then brush them with a dry, clean KS-14208 brush as covered in (c).	
—	Current Transformer, Weston Model No. 539 (used with Weston Model No. 528 AC Ammeter, 1 ampere, for measuring current values higher than 50 amperes)	(a) Pour a small quantity of the ♦trichloroethane♦ into a 1-ounce bottle. It is important to avoid the use of contaminated ♦trichloroethane♦ in cleaning the contacts. Therefore, discard	
MATERIALS			
KS-2423	Cleaning Cloth		
KS-6232	Light Mineral Oil		
KS-7187	Bond Paper		
KS-8321	Dashpot Oil		
KS-19578 L1	Trichloroethane	←	
—	Abrasive Cloth, 150 Grade		
—	Asbestos Pad		
—	1-Ounce Bottle		
TEST APPARATUS			
81A	Test Set (buzzer)		
352AL	Transformer		
—	Autotransformer, Continuous Tap (Variac, 2.5-ampere,		

the trichloroethane as soon as it appears slightly dirty.

(b) Dip the hairs of a clean KS-14208 brush their full length in the trichloroethane. Remove excess fluid by wiping the brush on the edge of the bottle. Then, with the pair of contacts open, brush the entire surface of the contact to be cleaned with the moist brush.

(c) Brush the contacts with a dry, clean KS-14208 brush.

(3) **Removing Buildups:** There shall be as little smoothing of contacts as is consistent with satisfactory operation. Contacts should be smoothed while closed, where practicable. To remove buildups, use the 374A burnisher blade held in the 373D contact burnisher holder. Insert the blade between the contacts and move it back and forth until the buildups are reduced enough to ensure reliable contact. Exercise care to avoid reducing the height of the contact. After burnishing, brush the contacts with a dry KS-14208 brush. For large copper contacts, a KS-2662 file may be used if necessary. Clean the contacts as outlined in (2) after smoothing.

Allen-Bradley Solenoid-Type Contactors

(4) Access to the main contacts can be had by removing the arc hood cover. Use the 3-inch C screwdriver for the smaller contactor and the R-1542 adjustable wrench for the larger. The instruction relative to the contacts, "Never clean, etc." which appears on some nameplates, refers to the use of a file. Contact condition should be checked primarily by a temperature rise measurement and also visually. Severely eroded contacts, ie, those with minimal contact material remaining should be replaced even though meeting the temperature rise requirement. If any of the contacts should require replacement, replace the entire set. The stationary contacts are replaced by replacing the entire arc chamber in which they are mounted. To replace the movable contacts, press down with the fingers, rotate the contact bar 90 degrees, and lift it off the stud. Install the new contacts by a reverse operation.

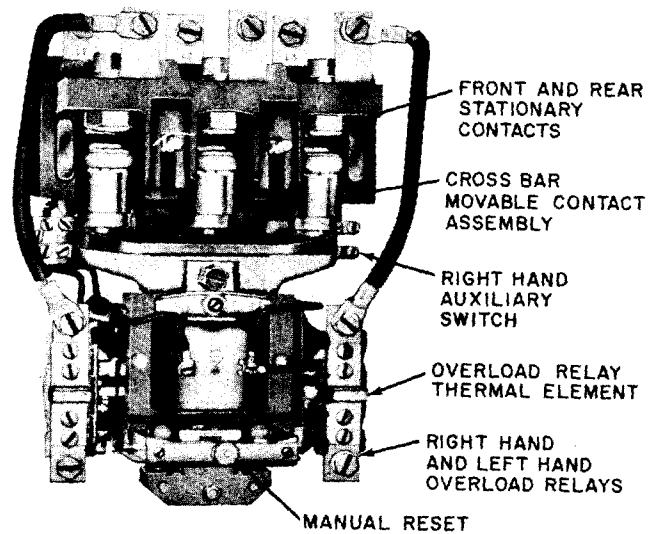

Fig. 3—Allen-Bradley Solenoid Type Contactor (with ARC Hood Removed)

(5) Where auxiliary contacts are present, they may be cleaned as outlined above. To replace them, it will be necessary to dismantle the contactor.

Ward Leonard Contactors

(6) Access to the main contacts in the type of contactors shown in Fig. 4 can be had by removing one screw from each side of the contactor, thus releasing the head. One screw is located close to the auxiliary switch and the other in a corresponding position on the other side of the contactor.

(7) The movable contacts can be released for replacement by removing the slotted collars. The stationary contacts can be removed with a screwdriver.

(8) The contacts in totally enclosed auxiliary switches are not accessible. If they fail to make reliable contact, or if oil or grease is observed in the mechanism, remove as much of the oil or grease as possible using trichloroethane on a cloth wrapped around the flat end of an R-1102 fiber spudger. If, after operating the switch manually, the contacts still fail to make reliable contact, replace the switch.

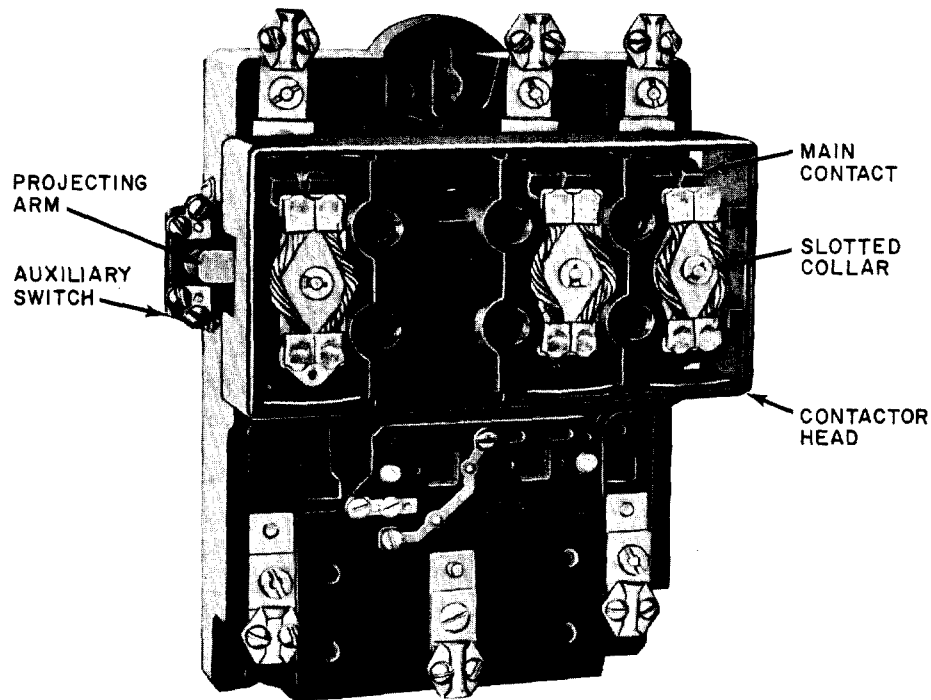

Fig. 4—Ward Leonard K-40818 Contactor

KS-5770, KS-15841, and KS-15861 Starters

(9) To obtain access to the main contacts, remove the steel strap (1) and slide out the contact assembly. The stationary main contacts (7) can be removed individually for replacement by removing the associated key (8) and rotating the contact. To remove movable contacts, press down, rotate 90 degrees, and withdraw. If the contacts fail to meet the requirements for freedom of buildups, they may be smoothed with the burnisher or with 150-grade abrasive cloth while the contact assembly is removed from the starter. See Fig. 5.

3.03 Contact Alignment (Reqt 2.03)

(1) Where feasible, correct by making necessary adjustments with pliers. In other cases, correct by loosening the bolts which hold the contact carrying arm on the shaft to obtain

play, and moving the arm as required. Tighten the bolts before leaving.

(2) If alignment cannot be obtained, make replacements as required.

3.04 Contact Sequence (Reqt 2.04)

(1) If contacts do not make or break approximately at the same time, inspect the group for any that are out of alignment with the others. Correct by shaping the contact springs with the P long-nose pliers or raising or lowering stationary contact assemblies, as required, to bring them into alignment with the others of the group. When the contacts are supported by heavy members which cannot be shaped with the pliers, check for mechanical trouble which may require the replacement of parts. Check 2.03, 2.05, 2.06, and 2.08 after any change.

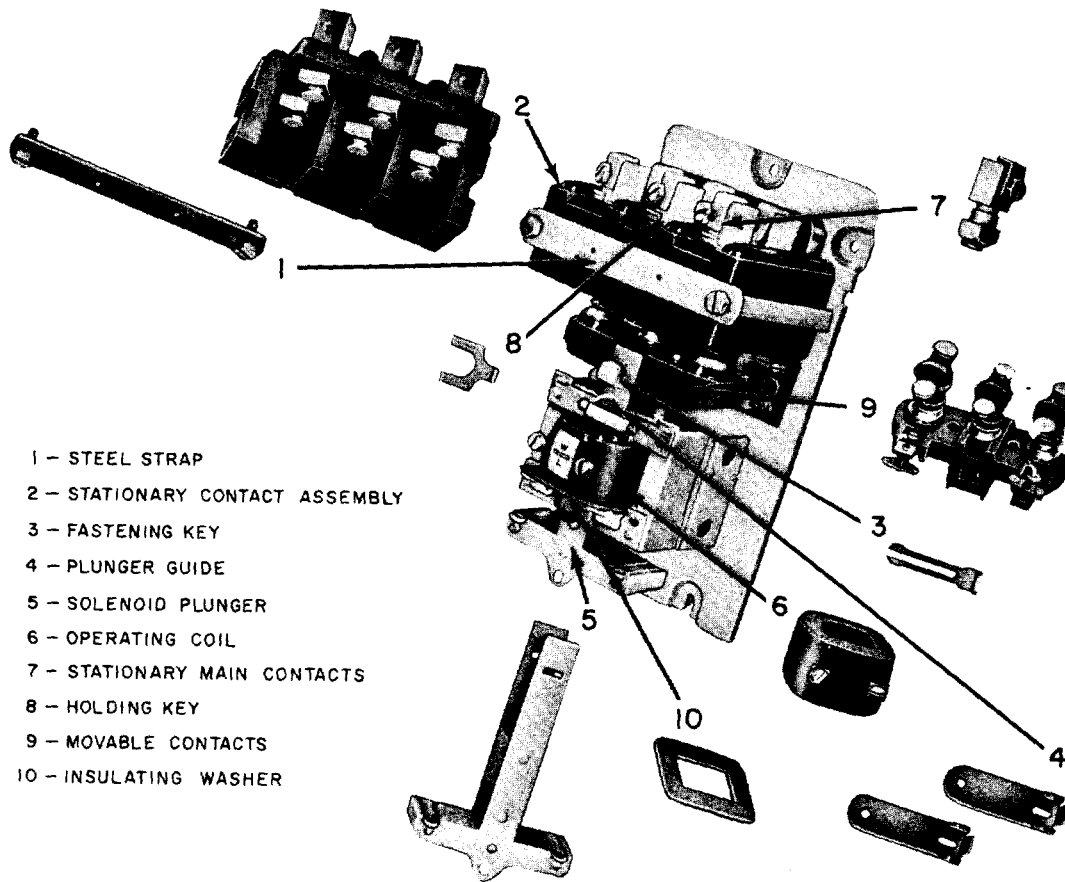

Fig. 5—General Construction of KS-5770, KS-15841, KS-15861 Starters—KS-5770 Illustrated

3.05 Contact Separation (Reqt 2.05)

(1) For contactors of the general type of the Ward Leonard Bulletin 4401 (Fig. 6), measure contact separation of NC contacts with the contactor operated and of NO contacts with the contactor released. Adjust by shaping the movable contact support.

3.06 Contact Pressure and Follow (Reqt 2.06)

Clapper-Type Contactors

(1) To check the contact pressure of NC contacts, attach a short loop of cord around the movable contact and insert a small piece of KS-7187 bond paper between the contact surfaces. Hook the gauge or spring balance in the loop

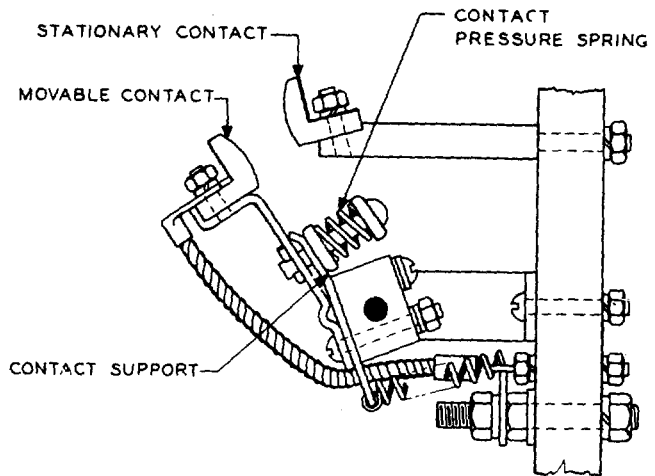

Fig. 6—Ward Leonard Bulletin 4401 Contactor

and pull away from the stationary contact. Observe the indication of the gauge or spring balance at the instant the paper can be moved.

(2) To check the contact pressure of NO contacts, proceed as above with the contactor operated. The contactor may be operated manually or electrically by means of a temporary connection to the operating coil. See that the contacts are not connected to the service voltage while being handled.

(3) If the requirement is not met, examine the contacts and contact support for mechanical trouble. Replace weak contact spring and badly worn contacts as necessary.

Solenoid-Type Contactors

(4) When checking contacts for follow, close the contactor or starter slowly by hand observing the distance the support can move after the contact is first made. An 81A test set (buzzer) connected across the contacts will be helpful in determining the point at which they make.

(5) In general, correction for the lack of follow involves either the adjustment of contacts to increase the contact pressure or, if this is not feasible, the replacement of weakened springs or other appropriate parts.

3.07 Overload Relays (Reqt 2.07)

(1) To adjust the Cutler Hammer relay (Fig. 7), loosen the screws that hold the covers in place and reposition both covers to bring the indicators opposite the desired graduation on the calibration plate. Adjust both covers of the relay to the same graduation.

(2) To adjust the Allen-Bradley relay which is shown in Fig. 8, remove the dashpot. Turn the core until the desired calibration line is flush with the top edge of the dashpot. Use care to avoid spilling oil out of the dashpot. If there is reason to believe that the oil in the dashpot has become gummy or dirty, it may be replaced, first removing the piston which is carried by the core. To remove, gently knock the coverplate loose from the top of the dashpot by pulling upward on the core. Clean out the old oil and refill with KS-8321 dashpot oil, if readily available,

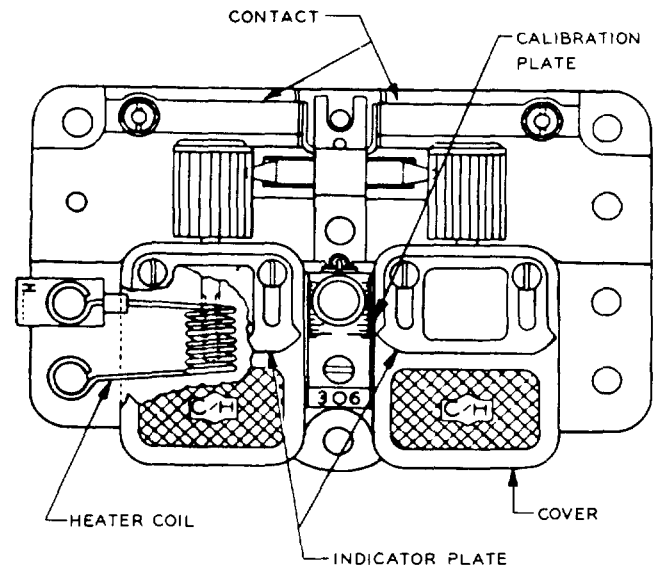

Fig. 7—Cutler Hammer Overload Relay

or with KS-6232 light mineral oil, and fill until the projections on the top of the piston are just covered.

Test Procedure

(3) This procedure applies for the test requirement of single-phase starters and 3-phase starters having a full-load motor current of 25 amperes or less.

(4) Open the ac supply at the switch and fuse unit by removing fuses or opening the motor circuit disconnect switch. Set up a test circuit as shown in Fig. 9. Connect terminals 1 and 3 of the 352AL transformer to the L and T terminals of the overload relay; terminals 4 and 210, 230, or 250, depending on line voltage, are connected to the output of the autotransformer. With the above arrangement, current up to 62-1/2 amperes at 2.5 volts ac can be obtained by manipulation of the autotransformer. With the test autotransformer, adjust the current to the required value.

(5) If no current flows when voltage is applied with the autotransformer, replace the heater coil. If a nonadjustable relay does not operate within 5 minutes, replace the relay. If an adjustable relay does not operate within 5 minutes, readjust the relay as covered in (1) or

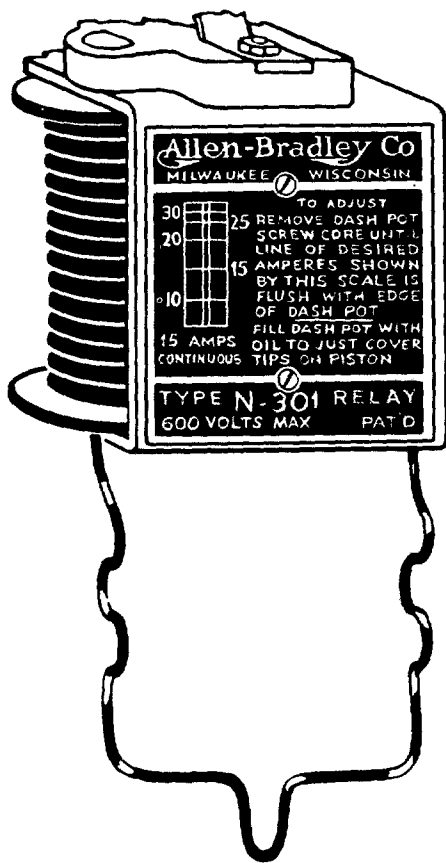

(2). Reset the relay after test. For 3-phase starters, repeat for the other heater coils.

Note: If the overload relay is thought to be at fault on starters having a full-load motor current of 25 amperes or more, it is suggested that a new overload relay be installed and the defective relay be sent to the supplier for repair.

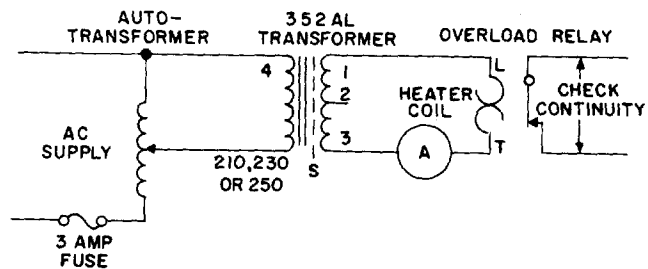

Fig. 9—Test Circuit for Checking Overload Relays

3.08 KS-5309 Starter (see Fig. 1) (Reqt 2.08)

(1) If the motor experiences a heavy surge when the RUN contactor closes, change the spring adjustment to increase the compression on the spring. Loosen the nuts, turn them down on the rod, and retighten.

Note: The lines on the core correspond to the ampere scale on the nameplate.

3.09 Electrical Requirements (Reqt 2.09)

(1) **AC Contactors:** A check of the operation of a clapper or solenoid-type contactor is made as follows. With power removed from the contactor as covered in 1.10, connect the coil of the contactor to be tested across the output of a continuous tap autotransformer. Connect the Weston Model 528 voltmeter across the output of the autotransformer. Connect the input of the autotransformer to the ac supply through 3-ampere fuses. Adjust the output of the autotransformer to the desired value.

(2) Failure to operate with rated voltage at the coil terminals may sometimes be corrected by readjustment, but, in some cases, may be

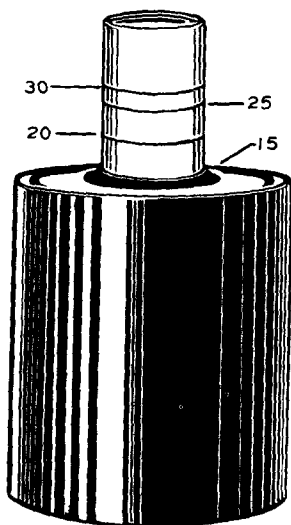

Fig. 8—Allen-Bradley Overload Relay

due to an open coil. To check for an open coil, connect the voltmeter in series with the operating voltage and the coil. The absence of an indication on the voltmeter when so connected shows that the coil is open and should be replaced.

(3) If the contactor does not release, check for binding of the armature, solenoid, linkage, etc. Clean with ♦KS-19578 L1 trichloroethane♦ on a KS-2423 cloth wrapped around a KS-6320

orange stick. When any change is made in mechanical settings, care should be taken that the other requirements continue to be met.

3.10 Temperature (Reqt 2.10)

(1) If the temperature exceeds the specified limits and the other requirements are met, refer the matter to the supervisor.