

## CONTACTORS

### KS-15514 AND KS-15934

### REPLACEMENT PARTS AND PROCEDURES

#### 1. GENERAL

**1.01** This section covers the information necessary for ordering parts to be used in the maintenance of KS-15514 and KS-15934 contactors manufactured by the Automatic Switch Company.

**1.02** This section is reissued to:

- Add ordering information for the conversion of KS-15934 L1 through L11 to KS-15934 L21 through L31 contactors.
- Revise ordering information for the conversion of KS-15514 to KS-15934 contactors.

**1.03** Part 2 of this section covers the various parts which it is practicable to replace in the field in the maintenance of this equipment. No attempt should be made to replace parts not designated. Part 2 also contains explanatory figures showing the different parts. This information is called Replacement Parts.

**1.04** Part 3 of this section covers the approved procedures for the replacement of the parts covered in Part 2. This information is called Replacement Procedures.

#### 2. REPLACEMENT PARTS

**2.01** The figures included in this part show the various replacement parts in their proper relation to other parts of the apparatus together with their corresponding names.

**2.02** When ordering replacement parts, give the name of the part as shown in the figures of this section and the complete nameplate data of the contactor including the manufacturer's name, for example, 4 auxiliary stationary contacts for the Automatic Switch Company contactor, Bulletin No. 906-1055, control voltage 190/253, 60 Hz, 600

amperes per KS-15934 L9. Do not refer to this section number.

**2.03** Information enclosed by parentheses ( ) is not ordering information. This information may be references to notes, parts referred to in other portions of the section and not considered replaceable, or part names in general use in the field if these names differ from those assigned by the manufacturer.

**2.04** Miscellaneous parts, ie, screws, cotter pins, etc, which are not named in the illustrations and which cannot be obtained locally should be ordered by describing the part and giving the complete nameplate data of the contactor as covered in 2.02.

**2.05** *KS-15514 Contactors:* Fig. 1 and 2

- (a) It is recommended that the KS-15514 contactor be converted or replaced by the KS-15934 contactor in those areas where the KS-15514 contactor fails to transfer completely or where coil burnouts have been experienced. It is also recommended that the KS-15514 contactor be converted or replaced in those field installations having normal voltages of 208. The telephone companies may change sets of any other voltage.

**Note:** The conversion consists of substituting the ac solenoid of the KS-15514 contactor with a dc solenoid and rectifier unit. In addition, a new nameplate is furnished to indicate that the changed contactor corresponds to the new KS number.

- (b) Kits containing all the necessary parts and detailed instructions to convert existing KS-15514 contactors to KS-15934 are available on order. Kits should be ordered by specifying the Automatic Switch Company drawing number, the ampere capacity, and the applicable KS number as follows:

A. S. CO DWG NO.	AMPERES	LIST NO.	
		KS-15514	KS-15934
73-400M	150	L1	L21
73-401M	100	L2	L22
73-402M	150	L3	L23
73-403M	200	L4	L24
72-973M	300	L5	L25
76-536M	30	L6	L26
76-537M	75	L7	L27
76-538M	75	L8	L28
73-404M	600	L9	L29
73-405M	400	L10	L30
73-406M	200	L11	L31

2.06 ♦KS-15934 Contactors (Fig. 2)♦

(a) ♦It is recommended that the KS-15934 L1 through L11 contactors be converted or replaced by the KS-15934 L21 through L31 contactors in those areas having a history of rectifier failure and where transient high voltage sources are known to exist. The KS-15934 L9 contactor is particularly susceptible to failure due to the large switching current.♦

**Note:** ♦The conversion consists of substituting the diode rectifier bridge and R.C. network

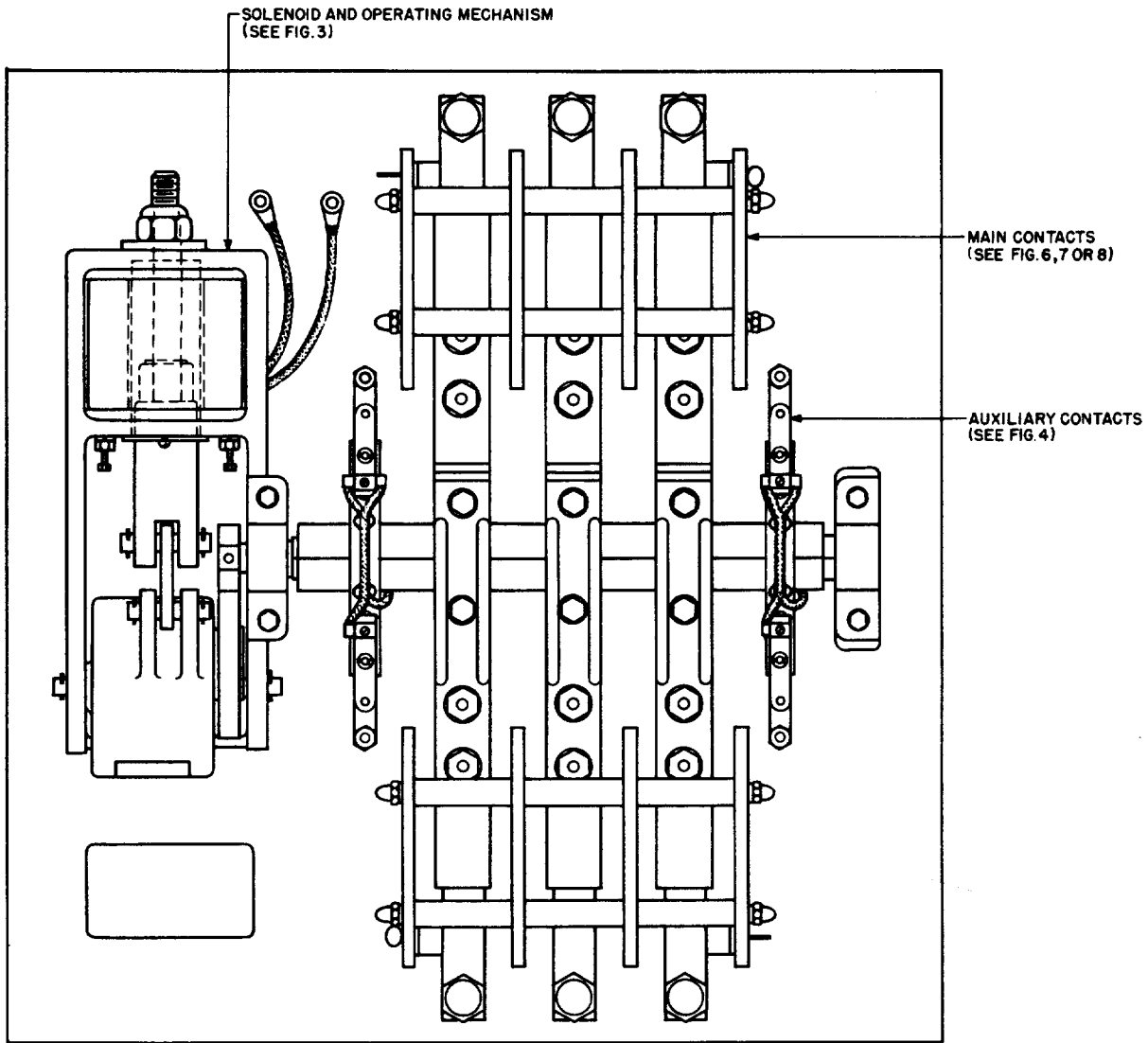

Fig. 1—Typical KS-15514, 30-, 75-, 100-, and 150-Ampere Contactors and KS-15934, 100- and 150-Ampere Contactors

of the KS-15934 L1 through L11 contactors with a new rectifier unit and a selenium surge protector. In addition, a new nameplate is furnished to indicate the changed contactor corresponds to the new number.◆

(b) ◆Kits containing all the necessary parts and detailed instructions to convert existing KS-15934 L1 through L11 contactors to L21 through L31. Contactors are available on order. Kits should be ordered by specifying the Automatic Switch Company, KS-15934 L101 Modification Kit. The KS and list number, serial number, and wiring number obtained from the nameplate should also be included.◆

### 3. REPLACEMENT PROCEDURES

#### 3.01 List of Tools:

CODE OR SPEC NO.	DESCRIPTION
<b>TOOLS</b>	
417A	1/4- by 3/8-inch Open Double-end Flat Wrench
418A	5/16- by 7/32-inch Open Double-end Flat Wrench
KS-6367	7/16- by 5/8-inch Open Double-end Flat Wrench
KS-6854	Screwdriver
R-3193	9/32- by 11/32-inch Open Double-end Flat Wrench

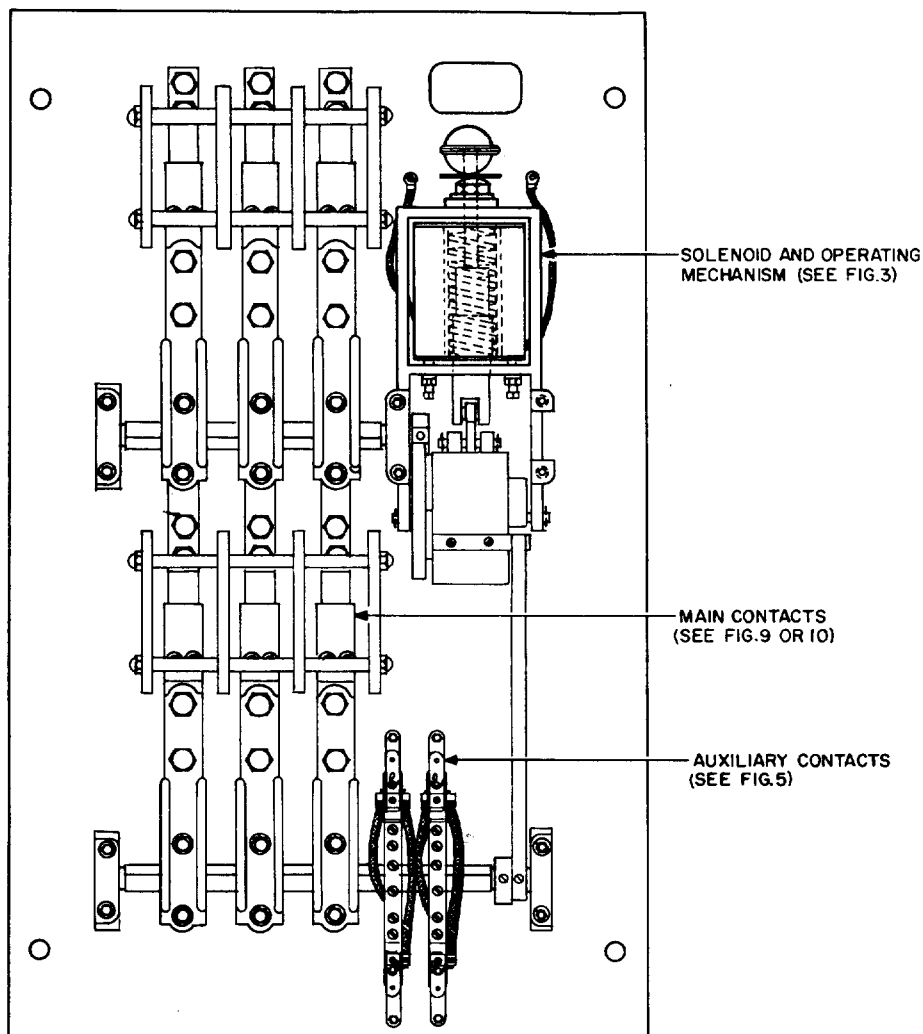

Fig. 2—Typical KS-15514 and KS-15934, 200-, 300-, 400-, and 600-Ampere Contactors

CODE OR SPEC NO.	DESCRIPTION
—	P Long-nose Pliers
—	4-inch E Screwdriver

**3.02** Disconnect the contactor from the power supply before making any replacement of parts. If the contactor operates in an automatic control circuit, the automatic control should be made inoperative as described in the appropriate section covering the apparatus.

**3.03** Before making any replacements, tag all leads if they are to be removed. After making any replacements, connect all leads to the proper terminals, making certain that they are secure.

**3.04** After making any replacement of parts, the part or parts replaced shall meet the readjust requirements involved as specified in Section 026-360-701. Other parts whose adjustments may have been directly disturbed by the replacing operations shall be checked to the readjust requirements and an over-all operation check shall be made before restoring the circuit to service.

**3.05 Operating Coil—Fig. 3**

(a) To replace the coil on contactors of 400 amperes and below, remove the stopnut and associated flat washer and threaded leather washer. Remove the weight pivot pin and draw out the weight and core assembly, and core spring from the frame. Remove the screw holding the core tube in place and pull out the core tube. Loosen the screws holding the coil in the frame and remove the coil. Reassemble new coil and parts in the reverse order. (3.04)

(b) To replace the coil on contactors of 600 amperes, remove the stopnut and associated flat washer and threaded leather washer. Since the coverplate is under pressure of the main core spring, exercise care in removing the screws holding the coverplate to the top of the frame. Remove the core link pin and lift the core tube out from the frame. Loosen the screws holding the coil in the frame and remove the coil. Reassemble new coil and parts in the reverse order. (3.04.)

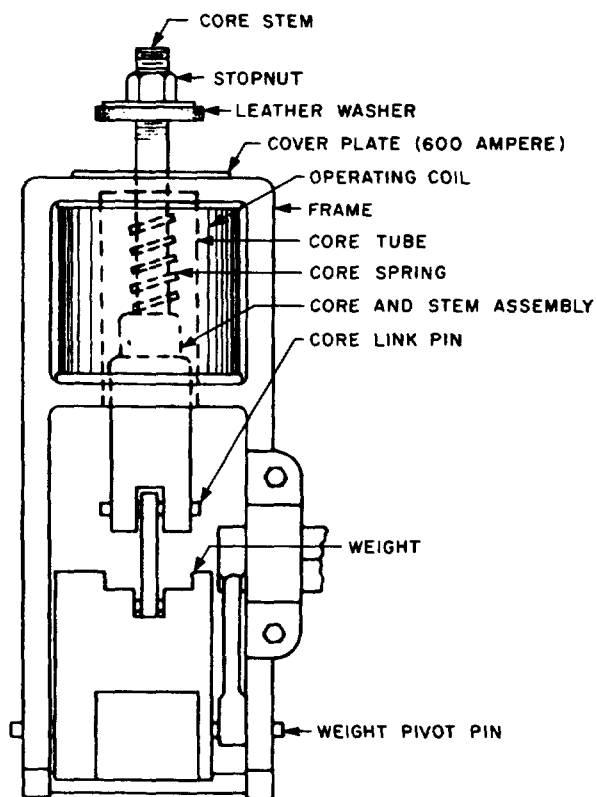

**Fig. 3—Typical Operating Solenoid Assembly**

**3.06 Movable Butt-Type Contacts—Fig. 4 to 7**

(a) To replace a movable contact, remove the cotter pin or nuts and washers on the movable contact spring stud and remove the spring and spring cup washers. Remove the pigtail holding screw or back pin and release the pigtail. Install new contact and spring as required. When replacing movable contacts, replace the associated pigtails and pigtail jumpers.

**3.07 Stationary Butt-Type Contacts—Fig. 4 to 7**

(a) Replace stationary contacts using a suitable open-end wrench.

**3.08 Brush Contacts—Fig. 8, 9, and 10**

(a) Remove the bolt and clamp holding the laminated brush contact and replace the contact. Where an arcing contact is provided,

replace both arcing contact and brush contact as an assembly.

### 3.09 Brush Contact Plate—Fig. 8

- (a) Remove the nut holding the pigtail to the brush contact plate and release the pigtail. Remove the locknuts on the bushings and remove the brush contact plate. When replacing brush contact plates, replace the associated pigtails.

### 3.10 Graphalloy Contact—Fig. 9 and 10

- (a) The graphalloy contact is held by a clamp-type holder and is easily replaced by loosening

the single clamping screw. When replacing parts of the graphalloy holder, replace the associate pigtail.

### 3.11 Brush and Graphalloy Contact Plates—Fig. 9 and 10

- (a) Both plates can be removed as an assembly by disconnecting the pigtail from the brush contact plate and removing the locknuts on the bushings. When replacing the contact plates, replace the associated main contact pigtails.

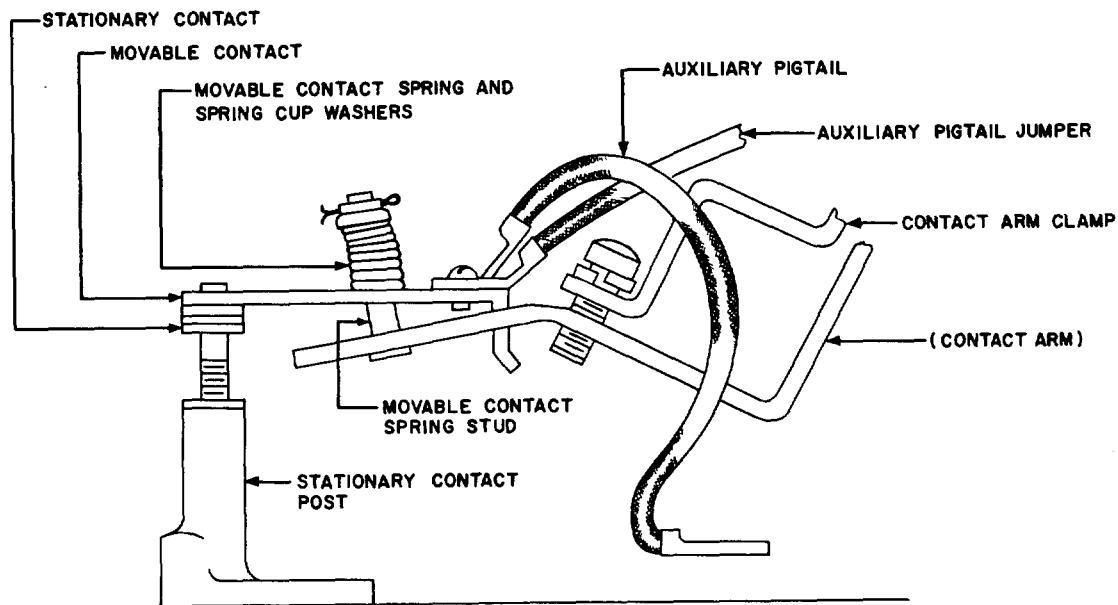

Fig. 4—Auxiliary Contact Structure (Butt Type) of 30-, 75-, 100-, and 150-Ampere Contactors

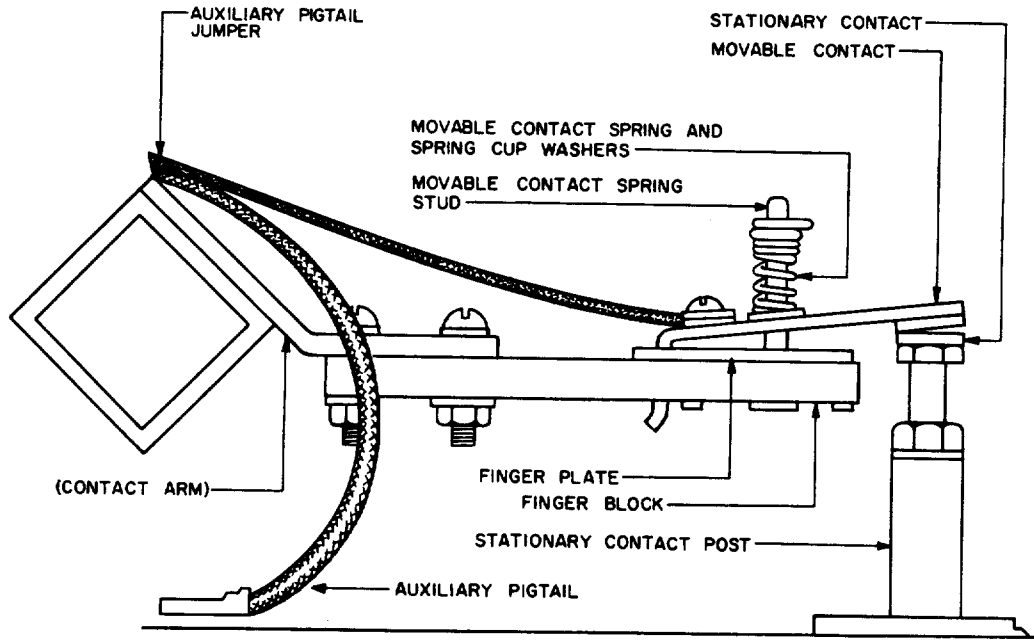

Fig. 5—Auxiliary Contact Structure (Butt Type) of 200-, 300-, 400-, and 600-Ampere Contactors

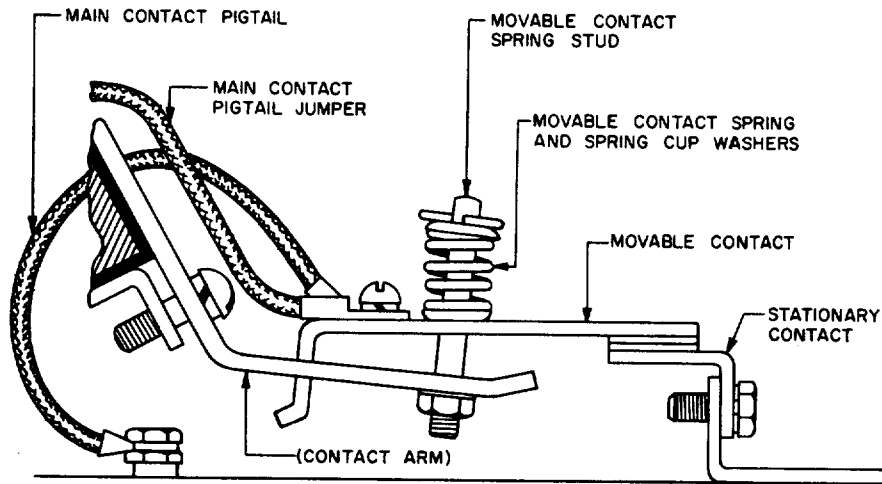

Fig. 6—Main Contact Structure (Butt Type) of 30-Ampere Contactors

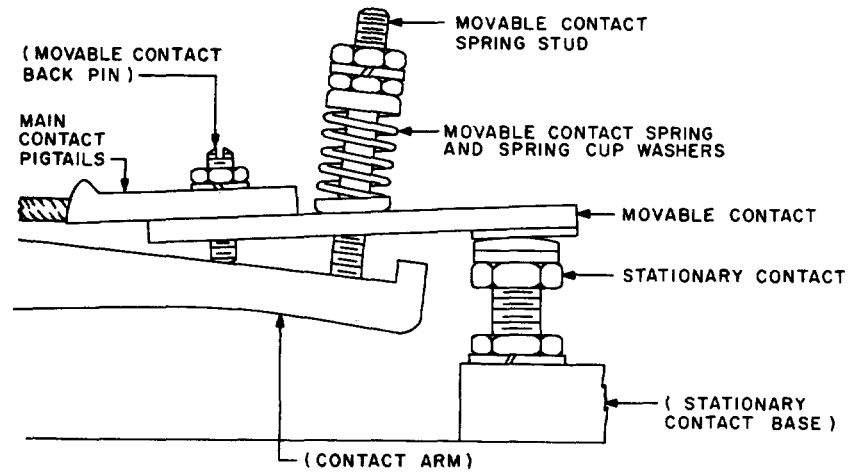

Fig. 7—Main Contact Structure (Butt Type) of 75- and 100-Ampere Contactors

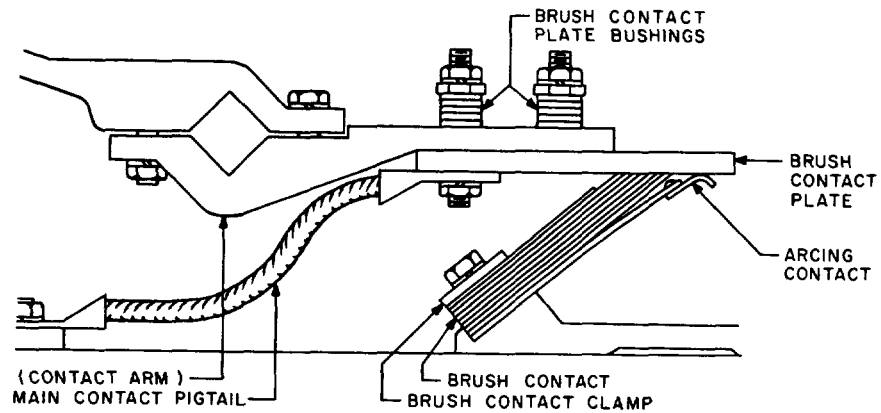

Fig. 8—Main Contact Structure of 150-Ampere Contactors

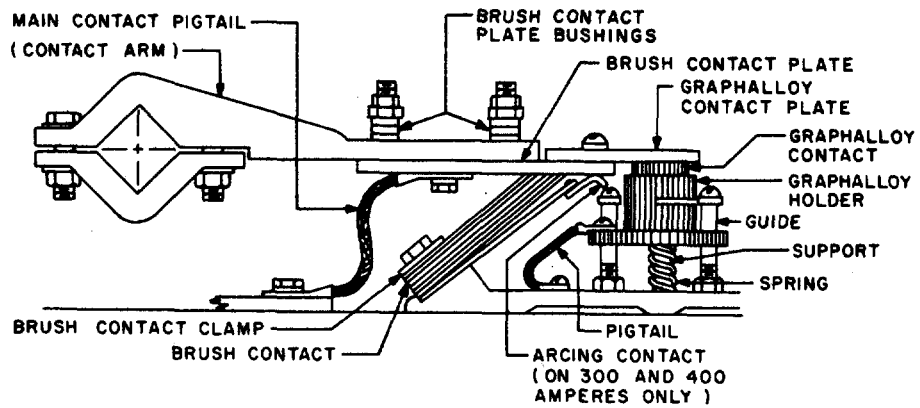

Fig. 9—Main Contact Structure of 200-, 300-, and 400-Ampere Contactors

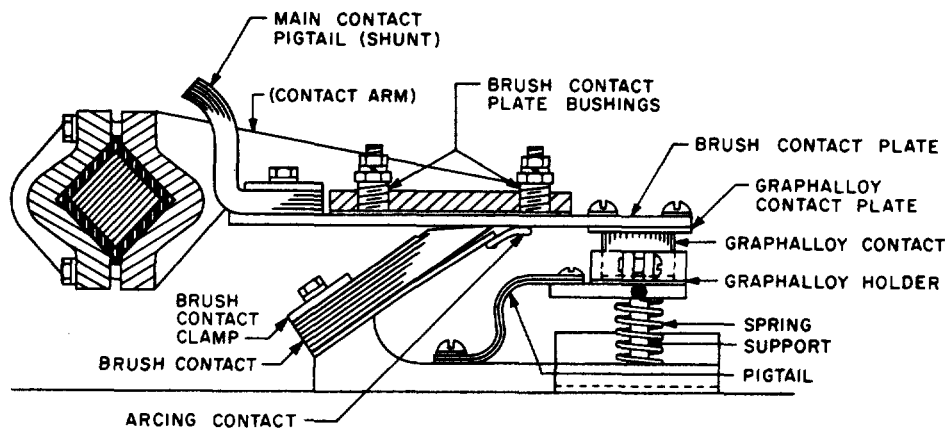

Fig. 10—Main Contact Structure of 600-Ampere Contactors