

## FUSE CAPS, BLOCKS, CLIPS, HOLDERS, MOUNTINGS, PANELS, AND POSTS REPAIR AND REPLACEMENT PROCEDURES

CONTENTS	PAGE	CONTENTS	PAGE
1. GENERAL . . . . .	2	9. Tooth in Locked Position . . . . .	9
2. APPARATUS . . . . .	4	10. Spring Stretched . . . . .	9
3. REPLACEMENT PROCEDURES . . . . .	4	11. P-344900 Fuse Caps . . . . .	10
A. Fuse Caps for Nonindicating-Type Fuses . . . . .	4	12. KS-14170 Fuse Block . . . . .	10
B. Fuse Caps for 70-Type Fuses . . . . .	5	13. KS-14473 Fuse Block . . . . .	10
C. Neoprene Washers for Fuse Caps for 70- Type Fuses . . . . .	5	14. KS-16364 Fuse Block . . . . .	10
D. Insertion and Removal of P-11F667 Fuse Cap Using 821A Insertion Tool . . . . .	5	15. KS-19393, L22, Fuse Block . . . . .	11
E. Fuse Blocks . . . . .	6	16. 20A Fuse Block Mounting Methods . . . . .	11
F. Fuse Clips . . . . .	12	17. 20A Fuse Block (Head Mounting Using 64A Bracket) . . . . .	11
G. Fuse Holders, Mountings, Panels, and Posts . . . . .	13	18. KS-20521 Typical Mounting Arrangement . . . . .	12
<b>Figures</b>		19. KS-21613, L1, Fuse Clip (Battery Terminal) . . . . .	13
1. KS-14169 Fuse Block . . . . .	3	20. KS-21613, L2, Fuse Clip (Load Terminal) . . . . .	13
2. P-21E517 and P-12F160 Fuse Caps . . . . .	4	21. KS-21613, L3, Fuse Clip (Alarm Terminal) . . . . .	13
3. P-11F667 and P-344900 Fuse Caps . . . . .	5	22. KS-5842 Fuse Holder . . . . .	14
4. Identification of Old and New Design Fuse Block Covers . . . . .	6	23. KS-15715 Fuse Holder . . . . .	15
5. 820B Tool . . . . .	7	24. KS-15858 Fuse Mounting . . . . .	15
6. 958A Fuse Block Repair Tool . . . . .	8	25. KS-19392, L2, Fuse Panel . . . . .	15
7. Fuse Panel . . . . .	8	26. KS-5083 Fuse Post . . . . .	16
8. Tool Insertion Into Spring Tang . . . . .	8	27. KS-14473, L4, Fuse Holder Puller Tool . . . . .	16

**NOTICE**

Not for use or disclosure outside the  
Bell System except under written agreement

CONTENTS PAGE

Table

A. KS-20521 Fuse Clips . . . . . 12

1. GENERAL

1.01 This section provides the information necessary for repairing and replacing the following fuse caps, blocks, clips, holders, mountings, panels, and posts used in telephone power plants:

9A	21A	30 Type
12 Type	22 Type	31 Type
13A	23 Type	34 Type
14A	24 Type	KS-14169
15 Type	25 Type	KS-14170
18 Type	26A	KS-14473
19A	27A	KS-16364
20A	29A	KS-19393

1.02 Revision arrows are used to emphasize significant changes. The Equipment Test List is not affected. The reasons for reissue are listed below.

- (a) To change the title
- (b) To add information on the replacement of the 20A fuse block
- (c) To rate the 820A tool Mfr Disc. and replaced by the 820B tool
- (d) To add a note on the KS-14169 fuse block
- (e) To add a note on link-type fuses.

1.03 **DANGER:** *Extreme care must be taken when working on or near equipment with high current capability and/or when high voltage is present. To prevent bodily injury, bracelets, rings, key chains, wrist watches, metal belts, and buckles should not be worn while inspecting or maintaining electrical equipment. Insulated tools (see Section 074-000-001), gloves, and mats should be used at all times. However; it is not necessary to use an insulated mat when working on dc distributing boards which do not exceed 135 volts.*

1.04 **DANGER:** *For link-type fuses, covers are to be left in place when no service is being performed. A fuse upon failing, particularly the link-type where the fuse metal is unprotected, usually becomes molten metal instantly and, if spattered, may cause serious injury to a person nearby.*

1.05 **DANGER:** *When it is not possible to remove potential from the fuse, clips, or current-carrying connections of high-voltage/current circuits, the adjacent clips or connections of opposite polarity shall be wrapped with canvas or friction tape to prevent accidental contact which might result in a short circuit or injury to the person. Terminals that are spring loaded and must be free to move to generate contact pressure (terminals such as the load terminals on fuse block KS-14169) should not be taped. The contact that is made through the movable terminal may be broken during the application or removal of the tape causing a service interruption. (See Fig. 1 for terminal identification.)*

1.06 **DANGER:** *Uninsulated metal tools, such as pliers, screwdrivers, and wrenches used for working on or near high-voltage/current circuits, should be insulated with three wrappings of friction tape, each wrapping applied with a half lap. If access to a nut or bolt is difficult and safety conditions warrant, the use of a box-end wrench may be advisable.*

1.07 **Caution:** *It is recommended that work on live equipment be performed during periods of light traffic. Each exception, including the temperature test of discharge fuses or removal of defective fuses, should be discussed with the supervisor before work is started since the removal of even an apparently minor fuse may result in a service interruption.*

1.08 **Warning:** *A fuse cap containing a fuse should not be removed from a "live" circuit for the purpose of de-energizing the equipment which the fuse is protecting. Accidental bumping of fuse caps in "live" circuits should also be avoided. Either of these occurrences can cause arcing of the current-carrying connections, and thus shorten fuse block life.*

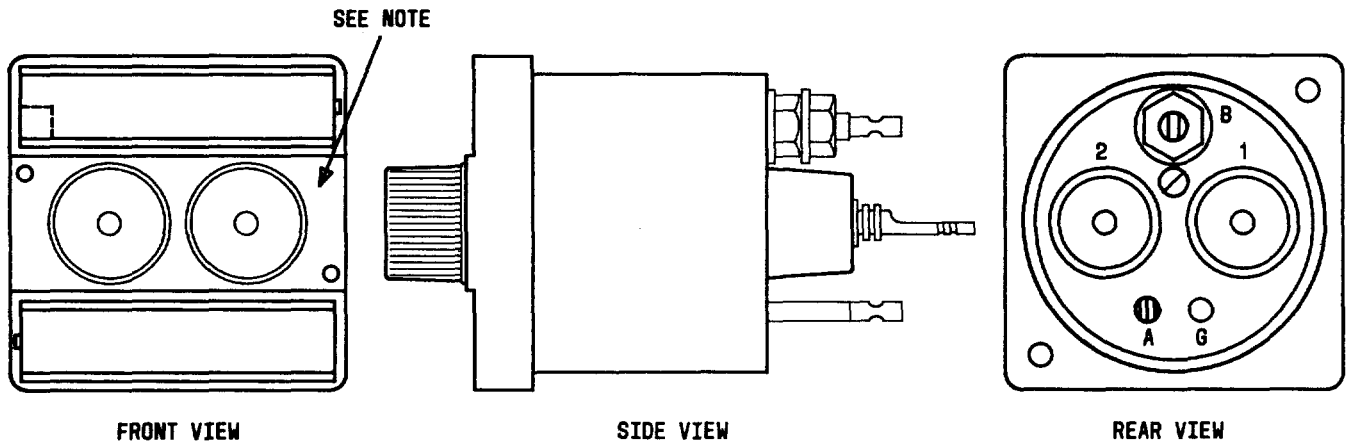

**NOTE:**  
 RAISED DOT OR RED "X" - FUSE BLOCK WITH MOVABLE LOAD TERMINALS (TERMINALS 1 AND 2)  
 RED "S" OR NO MARKING - FUSE BLOCK WITH FIXED LOAD TERMINALS (TERMINALS 1 AND 2)  
 "F" - FUSE BLOCK WITH FIXED LOAD TERMINAL IS (MOST RECENT DESIGN)

Fig. 1—KS-14169 Fuse Block

1.09 The following Bell System Practices are referenced within this section:

SECTION	TITLE
026-370-701	Fuses, Mountings, and Enclosures—Requirements and Adjusting Procedures
074-000-001	Index of Tools—Switching System and Power
074-220-125	Tools, Gauge and Glass, Reading—Description
074-226-119	Tools, Inserters—Description
074-257-133	Tools, Stretchers—Description

1.10 A fuse puller should be used for protection against voltage possibly present on circuits when removing or inserting spring clip mounted, cartridge-type fuses.

1.11 Potentials on fuses, clips, and connections, such as those found in grounded telegraph circuits and various power circuits, may be high.

1.12 When possible, service shall be disconnected at power distribution boards and from battery sources before working on fuses, fuse clips, or current-carrying connections.

1.13 If service must be maintained, no fuse shall be removed without first making provision for the maintenance of service. In some equipment, such as battery distribution panels, duplicate fuses are provided that should be switched into the active circuit to substitute for active fuses while they are being replaced.

1.14 When a fault occurs and it becomes necessary to remove a fuse, the matter should be reported to the supervisor. Such action is considered advisable since the removal or even an apparently minor fuse may result in a service interruption.

**SECTION 026-370-801**

**2. APPARATUS**

**2.01 List of Tools, Materials, and Equipment:**

The following tools, materials, and equipment are used in this section:

TOOLS	DESCRIPTION
34-001	Fuse Puller, Midget, Ideal Industries, Inc. (or equivalent)
34-002	Fuse Puller, 7-1/2 Inches, Ideal Industries, Inc. (or equivalent)
34-003	Fuse Puller, 12 inches, Ideal Industries, Inc. (or equivalent)
AT-7825	5-inch, E Screwdriver
417A	1/4-Inch and 3/8-Inch Open Double-End Flat Wrench
418A	5/16-Inch and 7/32-Inch Open Double-End Flat Wrench
820B	Tool
821A	Insertion Tool
958A	Fuse Block Repair Tool
KS-14473, L4	Fuse Holder Puller Tool
R-2512	Adjustable Wrench
<b>MATERIALS</b>	
—	Canvas or Tape
KS-20521	Fuse Clip (see Table A)
KS-21613	Fuse Clip (see Fig. 16, 17, and 18)
P-12F160	Fuse Cap (see Fig. 2)
P-21E517	Fuse Cap (see Fig. 2)
P-21E546	Neoprene Washer
—	Solder

EQUIPMENT	DESCRIPTION
KS-14510, L1	Volt-Ohm Milliammeter or Digital Type
—	Soldering Iron.

**3. REPLACEMENT PROCEDURES**

**3.01** After replacement of parts, the replacing parts shall meet the requirements specified in Section 026-370-701.

**A. Fuse Caps for Nonindicating-Type Fuses**

**3.02** It is recommended that a "two dot" fuse cap (Fig. 2) be substituted for the "one dot" (center dot only) fuse cap on the 20A nonmodular fuse block and the 22B, 23B, 25A, 26A, and 27A modular fuse blocks where trouble has been encountered or heating is evident.

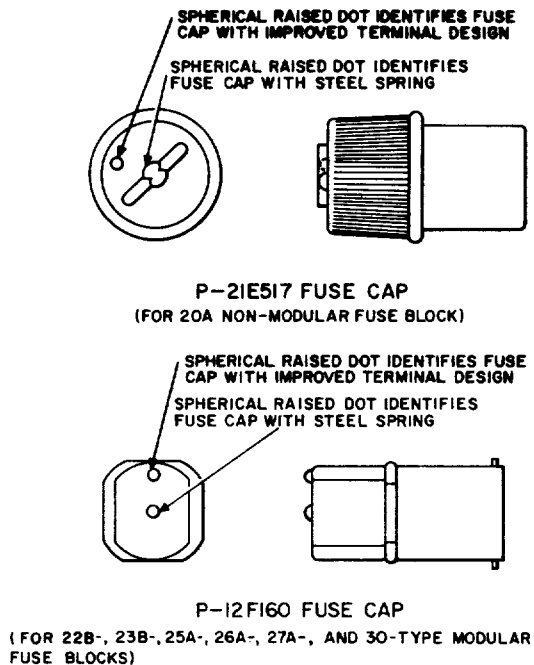

**Fig. 2—P-21E517 and P-12F160 Fuse Caps**

**3.03** To replace the old fuse cap, fully depress the cap, rotate approximately one-fourth turn counterclockwise, and remove the cap from the block. Insert and fully depress the new cap in the fuse block and turn approximately one-fourth turn clockwise. The latest design fuse cap, P-12F160 or P-21E517, can be identified by two raised dots and by the color of the spring. Fuse caps of the modular- and nonmodular-type fuse blocks are not interchangeable. No attempt should be made to replace the spring.

#### B. Fuse Caps for 70-Type Fuses

**3.04 DANGER:** *The P-11F667 fuse caps were intended for use with modular blocks and not with the KS-14169 blocks. The P11F667 caps will function electrically with the KS-14169 blocks, but do not completely shield the battery and alarm terminal slots. During violent fuse operation, these openings could act as vents for hot gases resulting in potential serious injury to personnel within 6 inches of the panel.* When removing or replacing a fuse cap (Fig. 3) containing a 70-type fuse, the fuse cap must be depressed fully before attempting to rotate approximately one-fourth turn into or out of position. Failure to follow this procedure on the new design 18- through 24-type fuse blocks (Fig. 4) could result in bending of the battery terminal.

#### C. Neoprene Washers for Fuse Caps for 70-Type Fuses

**3.05** The neoprene washer should not be used on fuse caps that are used on the 18-, 19-, or 21-type nonmodular fuse blocks. In addition, it should not be used on fuse caps that are used on new design 22-, 23-, and 24-type modular fuse blocks. These blocks have been redesigned and do not require the neoprene washer on the fuse cap. The use of the washer with the new design 22-, 23-, and 24-type blocks will prevent the fuse cap from being fully depressed. Hence, when the fuse cap is rotated into position, the battery terminal will probably be bent. In order to identify the new production 22-, 23-, and 24-type fuse blocks (Fig. 4), circular mounting screw holes are used on the new design fuse block cover whereas rectangular holes are used on the old design. Neoprene washers should only be added to fuse caps now in the field where interruptions to the battery supply have been experienced due to a slight movement to the fuse cap on old design 22-, 23-, and 24-type modular blocks and all 25-, 26-, and 27-type modular blocks.

#### D. Insertion and Removal of P-11F667 Fuse Cap Using 821A Insertion Tool

**3.06** The 821A insertion tool has been designed and produced to reduce the manual effort required to insert and remove the P-11F667 fuse cap (Fig. 3), used in modular-type fuse blocks, when equipped with the neoprene washer.

(a) To remove the fuse cap, proceed as follows:

- (1) Locate the 821A inserter tool over the fuse cap, and push in slightly.
- (2) Rotate the tool counterclockwise to its maximum position.
- (3) Retract the 821A insertion tool.

(b) To insert the fuse cap, proceed as follows:

- (1) Locate the 821A insertion tool over the end of the cap.

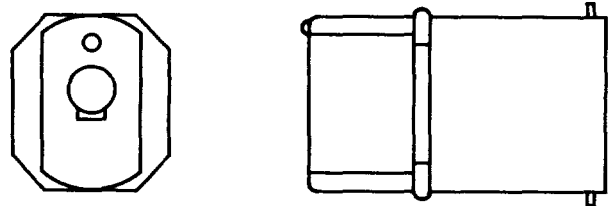

P-11F667 FUSE CAP

(FOR MODULAR FUSE BLOCKS TYPE NO. 22, 23, 24, 25, 26, 27, AND 29)

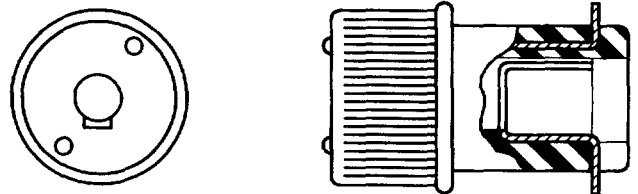

P-344900 FUSE CAP

(FOR NON-MODULAR FUSE BLOCKS TYPE NO. 18, 19 21 KS-14169, KS-14170, KS-14473, AND KS-16364)

Fig. 3—P-11F667 and P-344900 Fuse Caps

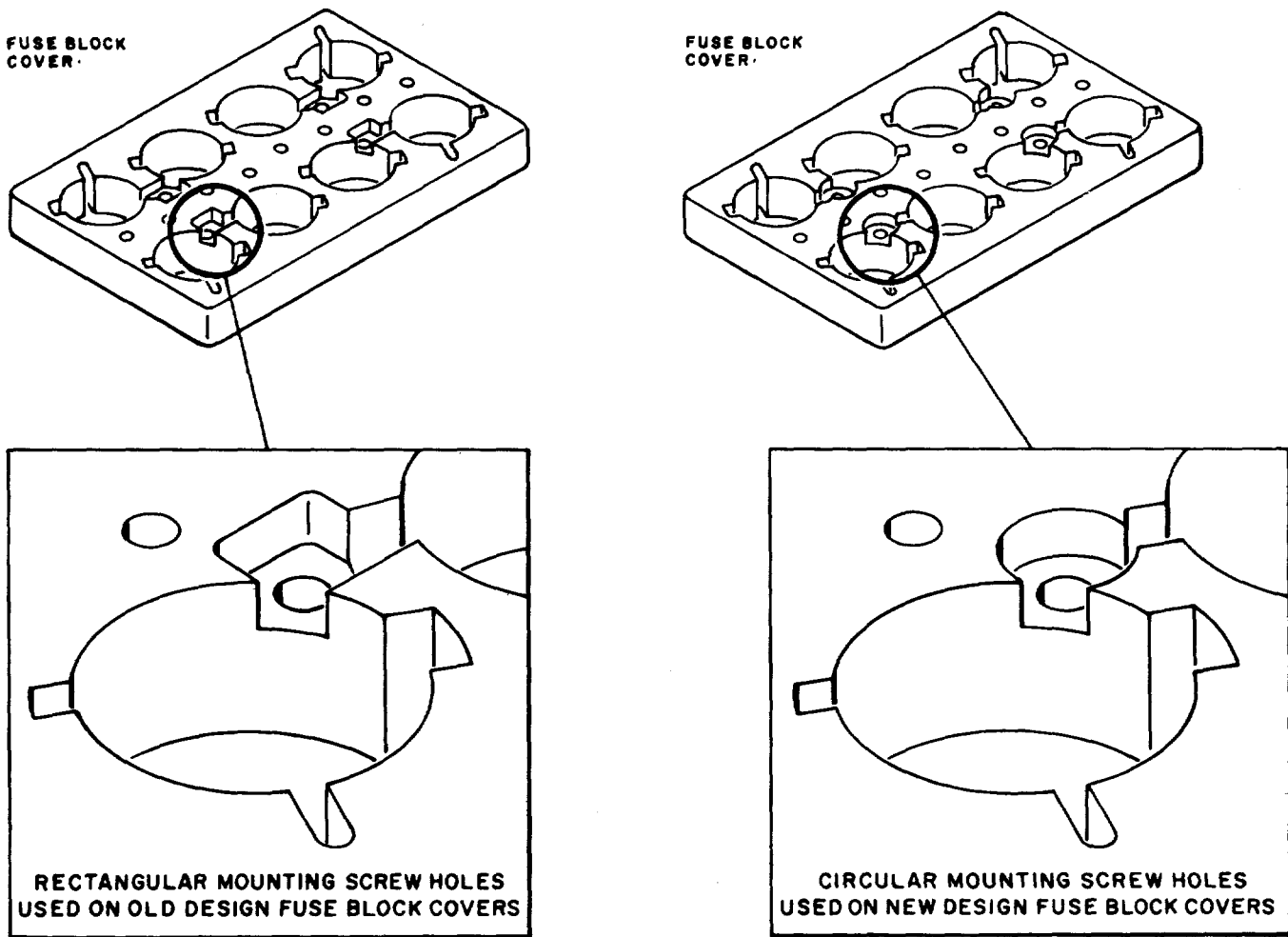

Fig. 4—Identification of Old and New Design Fuse Block Covers

- (2) Push in, without rotating, until the neoprene washer is slightly compressed between the face of the fuse block and the flange of the fuse cap.
- (3) Rotate the tool clockwise to its maximum position.
- (4) Retract the 821A insertion tool.

**Note:** See Section 074-226-119 for a description of the 821A insertion tool.

#### E. Fuse Blocks

**3.07 Silent Failures: Caution:** While maintaining equipment which contains KS-14169 fuse blocks, care must be taken to avoid creating silent failures (failures with no alarm) by moving individual wires or cables containing wires connected to spring loaded movable load terminals of the KS-14169 fuse block. (See Fig. 1.) Terminals 1 and 2 in the rear view are load terminals.

**After the maintenance work is completed, check to insure that continuity has been maintained in the circuits served by the KS-14169 fuse blocks, in and adjacent to the area, where the work was performed.** Silent failures (failure with no alarm) have generally occurred in KS-14169 fuse block installations where one or a combination of the conditions listed below exists or did exist.

◆**Note:** The latest design of the KS-14169 fuse blocks provides fixed terminals to eliminate silent failures.◆

- (1) Slack loops are inadequate.
- (2) Heavy wire (14 gauge or larger) has been soldered directly to the load terminals.
- (3) Load terminal leads are tied in a cable so that cable movement is transferred to the movable load terminals.
- (4) Leads have been soldered to the load terminals without removing a dummy fuse (72-type fuse) before soldering. This causes partial melting of the dummy fuse and a subsequent loss of clearance necessary for functioning of the movable load spring-loaded terminals.
- (5) Tape had been used to insulate terminals while working on adjacent apparatus. Either during tape application or tape removal, forces were applied to the movable, spring-loaded load terminal causing a loss of contact between the terminal and the fuse. (See paragraph 1.05.)

**3.08 ◆Spring Resilience:** To check the spring resilience of the 18-, 19-, 21- through 27-, 29-, 30B-, and 30D-type fuse blocks, proceed as follows:◆

- (1) Either place necessary jumpers across fuse line to continue service or check while service is disconnected.
- (2) Remove the fuse cap from the position to be checked.
- (3) Insert the ◆820B◆ tool with the tool flat (Fig. 5) positioned so that the tool clears the block designation pin (colored dot on the block).

- (4) If surface A of the ◆820B◆ tool (Fig. 5) contacts the fuse block before any force is felt against the spring, the spring is considered unsatisfactory. The spring is satisfactory if there is a gap, no matter how small, between the fuse block face and surface A, when the tool makes contact with the spring.

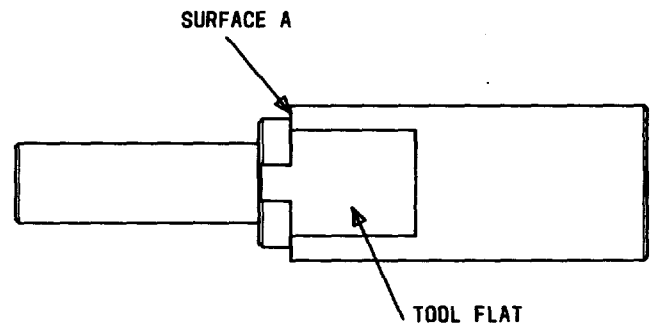

◆Fig. 5—820B Tool◆

**Note:** See Section 074-220-125 for description of the ◆820B◆ tool.

**3.09 Spring Extension Repair:** To stretch the spring of the 18-, 19-, or 21-type fuse blocks, or similar internal springs of modular fuse blocks (22-through 27-, 29-, 30B-, and 30D-type fuse blocks), using the 958A fuse block repair tool (Fig. 6), proceed as follows:

- (1) Either place necessary jumpers across fuse line to continue service or repair while service is disconnected.
- (2) Remove fuse cap and fuse.
- (3) Visually locate the position of the spring tang (Fig. 7) in the fuse block. Use a portable light if necessary.
- (4) Insert the tool into the block until the spring enters the slot of the stationary shaft of tool. (See Fig. 8.)
- (5) While applying a slight inward pressure on the tool, rotate the knurled wheel clockwise until it stops. This process engages the tooth into the first helix of the spring (Fig. 9).

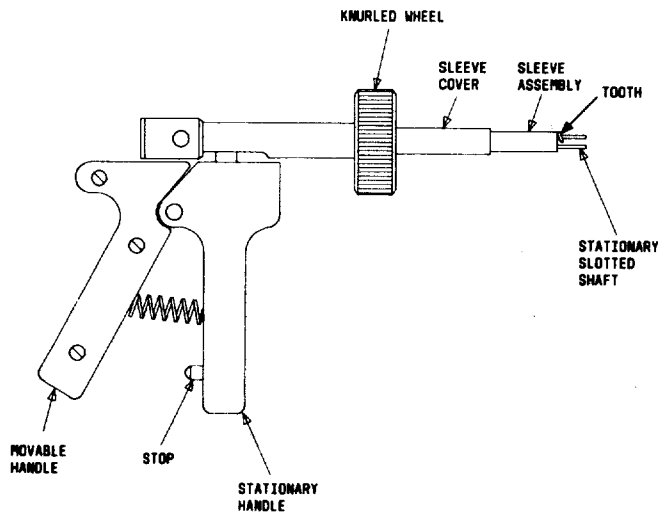

Fig. 6—958A Fuse Block Repair Tool

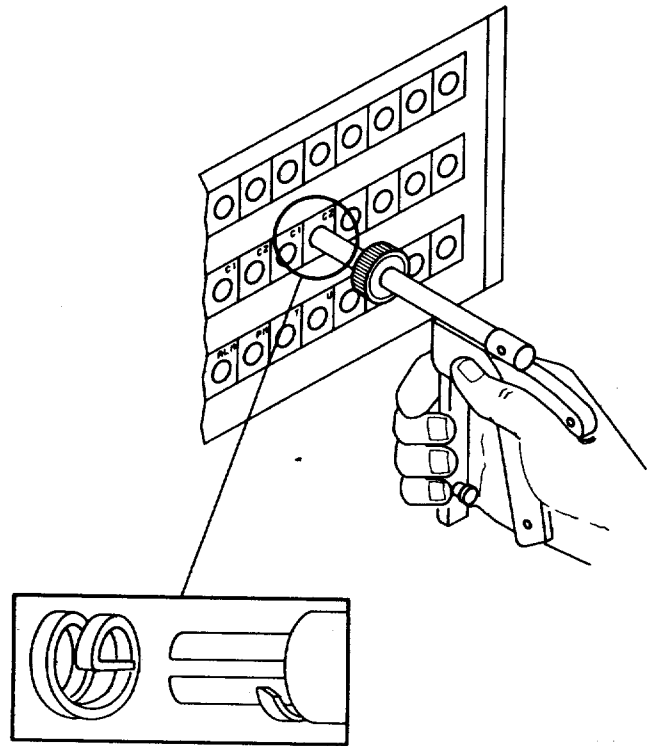

Fig. 8—Tool Insertion Into Spring Tang

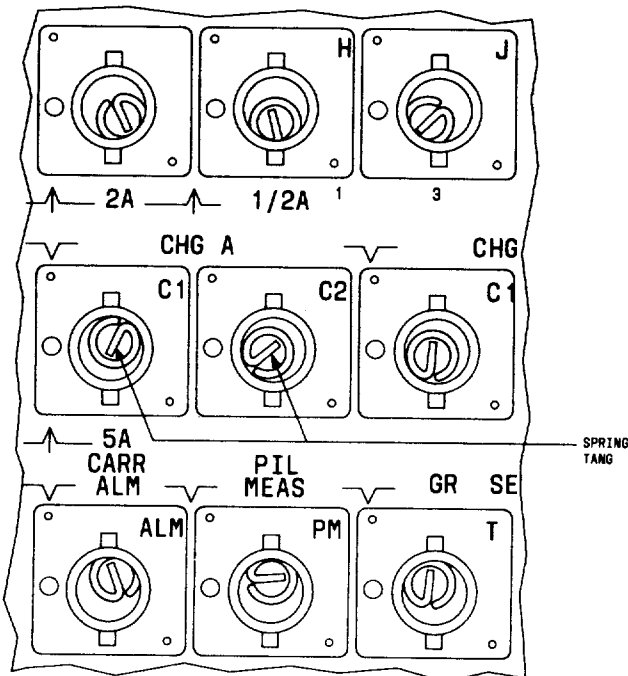

Fig. 7—Fuse Panel

- (6) Squeeze the handles until the movable handle contacts the stop of the stationary handle. This process stretches the spring between the sleeve and the end of the stationary shaft as shown in Fig. 10.
- (7) Release the handle and rotate the knurled wheel counterclockwise at least one-half of a turn to disengage the tooth of the sleeve from the spring.
- (8) Remove the tool from the fuse block.
- (9) **Warning:** The fuse cap used after spring stretching must be per latest design with the wide battery terminal. [See Fig. 11(a).] A fuse cap with a narrow battery terminal [Fig. 11(b)] should not be used after a spring is stretched. Replace fuse and fuse cap.



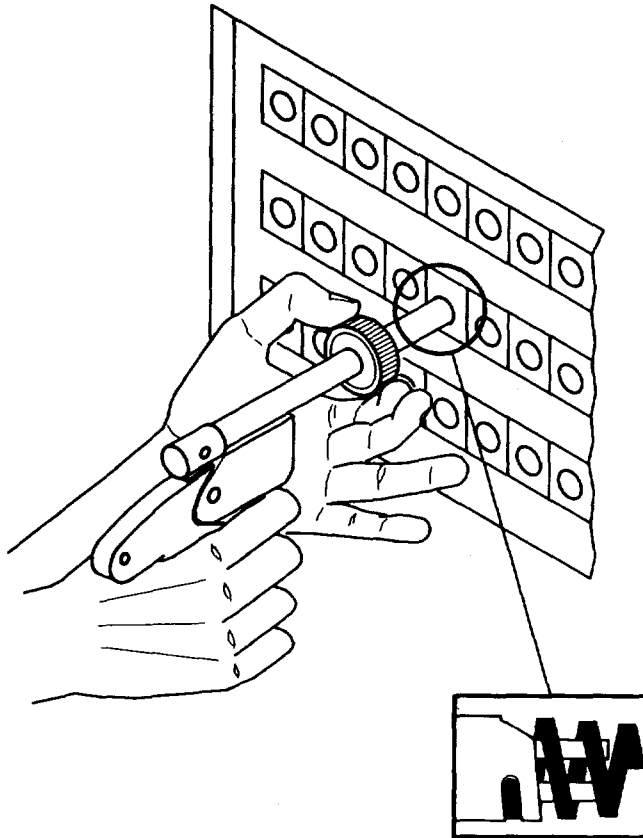

Fig. 9—Tooth in Locked Position

- (10) Remove jumper or restore the service.

**Note:** See Section 074-257-133 for description of the 958A fuse block repair tool.

**3.10** To replace all types of fuse blocks (Fig. 12 through 15), except the 31- and 34-type fuse blocks, proceed as follows:

- (1) Shut the power off.
- (2) **Warning: When using a soldering iron in the removal of the fuse block, remove the fuse from the block to prevent heat damage to the fuse.** Disconnect the wires from the terminals (note the wire color of each terminal). See subparagraph 3.11(2).

**Note 1:** Detailed circuit diagrams, showing terminal functions and position, should be available for reference. Even with circuit and wiring diagram information, each pin should be

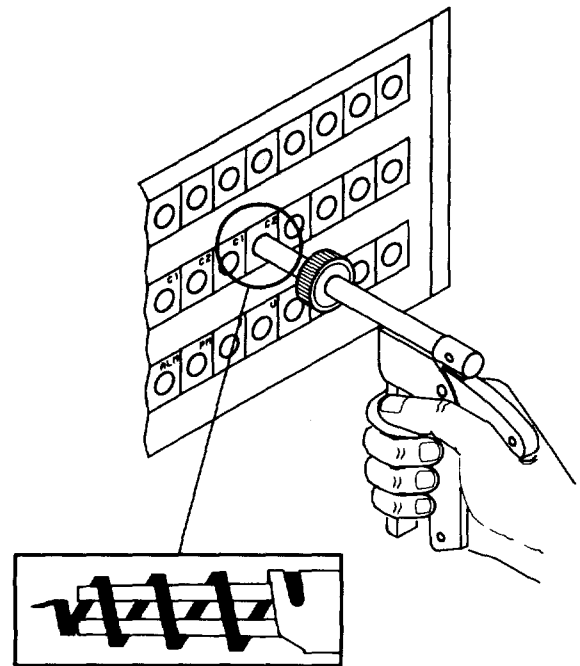
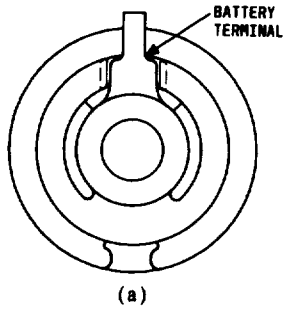

Fig. 10—Spring Stretched

checked, using a meter on a test probe, prior to initiating work.

**Note 2:** The KS-19393 fuse block and KS-19392 fuse panel are usually bus bar connected and extra care, such as taping exposed bus bars or covering the bus bars with insulating blankets, should be used to prevent accidental short circuits.

- (3) Remove the old fuse block from the unit and replace it with the new fuse block. [See subparagraph 3.11(5).]
- (4) **Warning: Do not connect the neutral wire to the alarm terminal, as this will damage the fuse block. The KS-14169, L3, fuse block is provided with a terminal marked G (ground).** Reconnect the wires on the terminals.
- (5) Replace the fuse and turn the power on.



(a)

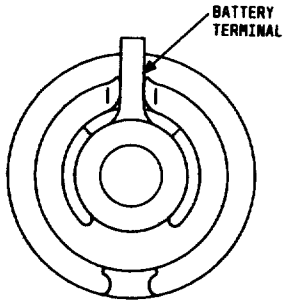

(b)

NOTE: FUSE CAPS P-344900 AND P-11F667 OF THE LATEST DESIGN (MANUFACTURED SINCE 1975) HAVE THE WIDE BATTERY TERMINAL SHOWN IN (a). FUSE CAPS P-344900 AND P11F667 OF THE OLDER DESIGN (MANUFACTURED PRIOR TO 1975) HAVE THE NARROWER BATTERY TERMINAL SHOWN IN (b).

Fig. 11 — P-344900 Fuse Caps

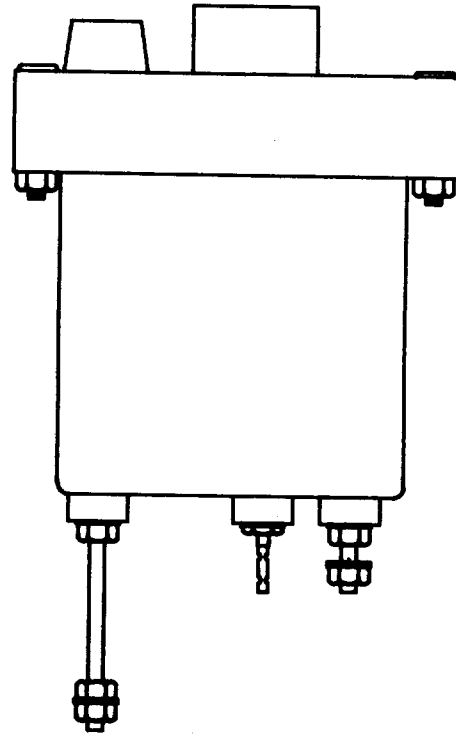

Fig. 13 — KS-14473 Fuse Block

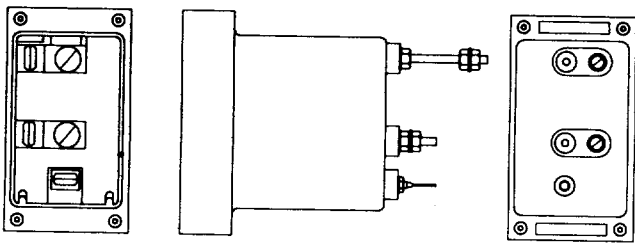

Fig. 12 — KS-14170 Fuse Block

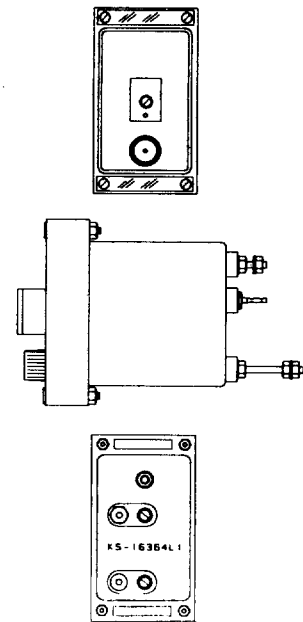

Fig. 14 — KS-16364 Fuse Block

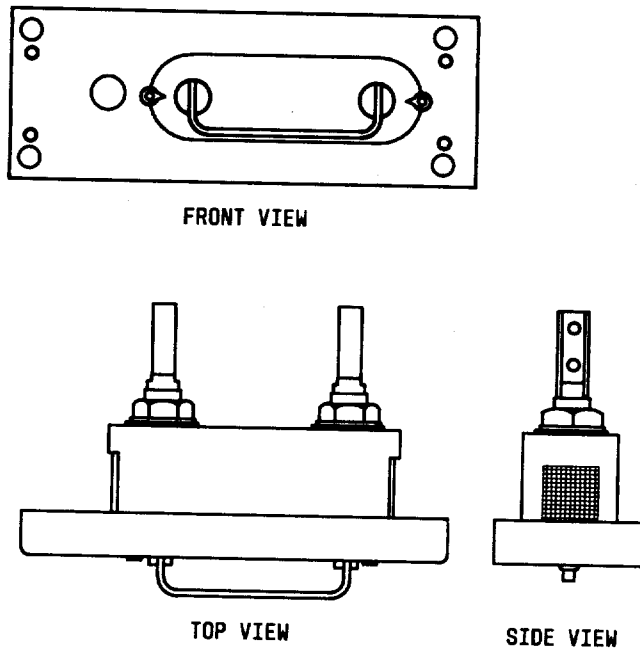

Fig. 15—KS-19393, L22, Fuse Block

3.11 ♦To replace the 20A fuse block, proceed as follows:

- (1) Shut the power off.
- (2) Remove the lead from the battery terminal by holding inner hex nut with a wrench while loosening the outer nut.
- (3) Remove the lead from the load terminal. [See subparagraph 3.10 (2).]
- (4) Remove the fuse block from the mounting panel.

**Note 1:** The 20A fuse block may either be head mounted or rear mounted (Fig. 16). The rear mounting is the preferred method for reason of strength and maximum voltage rating.

**Note 2:** If head mounting is necessary, 20A fuse block breakage can be alleviated by using the 64A bracket (a phosphor bronze bracket designed specifically for use with the 20A fuse block). (See Fig. 17.)

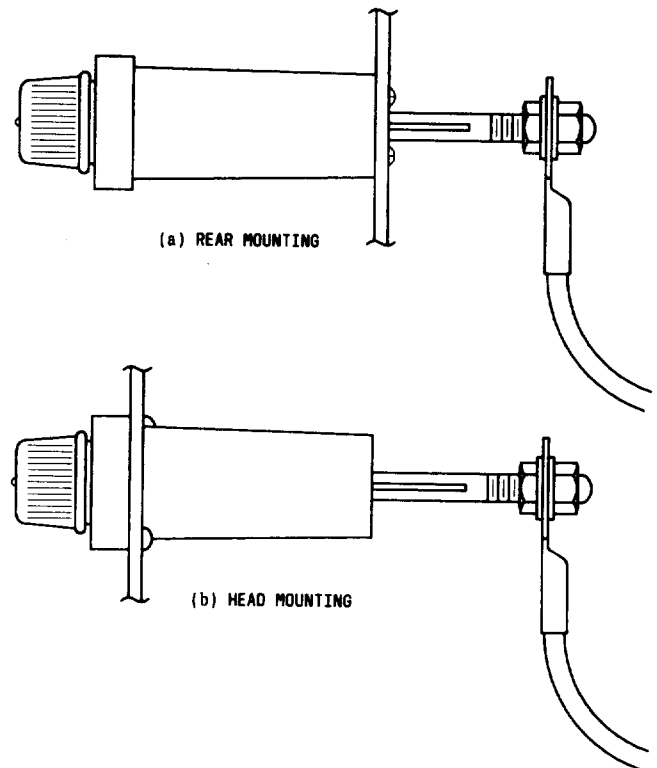

♦Fig. 16—20A Fuse Block Mounting Methods♦

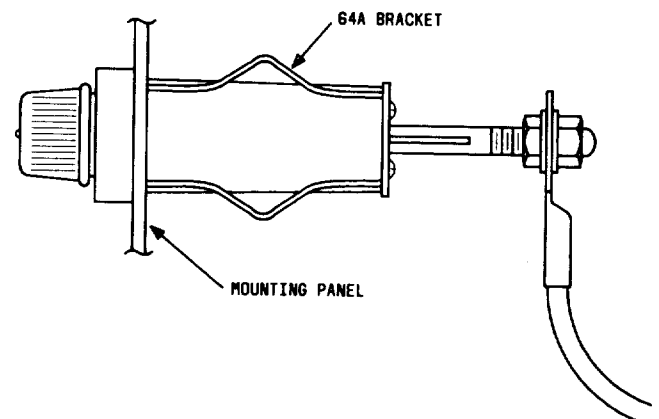

♦Fig. 17—20A Fuse Block (Head Mounting Using 64A Bracket)♦

**Note 3:** Where large leads are likely to exert loads which stress the fuse block, consideration should be given to the use of modular-type fuse blocks which have much greater strength.

(5) **Warning:** Regardless of whether the 20A fuse block is head mounted or rear mounted, leads should be performed prior to termination to minimize stress on the fuse block. The only acceptable method for securing the connection to the battery terminal is to hold one nut with a wrench while tightening the other nut with a second wrench to avoid imparting torque to other parts of the fuse block. Care must be taken to avoid applying side loads to the terminal during this operation.♦

**3.12** To replace the 31- or 34-type fuse block, proceed as follows:

- (1) Shut the power off.
- (2) Remove the solder from around the pins on the printed circuit board.
- (3) Remove the fuse block from the printed circuit board.
- (4) Replace with new fuse block and resolder the pins.
- (5) Turn power on.

#### F. Fuse Clips

**3.13** The KS-20521 fuse clips are used with cartridge, ferrule-type fuses and supersede the P-49472, P-65287, P-65288, and P-65289 fuse clips. Table A lists the KS-20521 fuse clips used with the specified ampere- and voltage-rated cartridge fuses.

**3.14** To replace the KS-20521 fuse clip, remove the old clip from the base. Substitute the new fuse clip, and replace as shown in Fig. 18.

TABLE A

KS-20521 FUSE CLIPS

FUSE CLIP PART NO.	FUSE RATING	
	AMPERES	VOLTS
KS-20521, L1	0-30	250
KS-20521, L2	31-60	250
KS-20521, L3	0-30	250

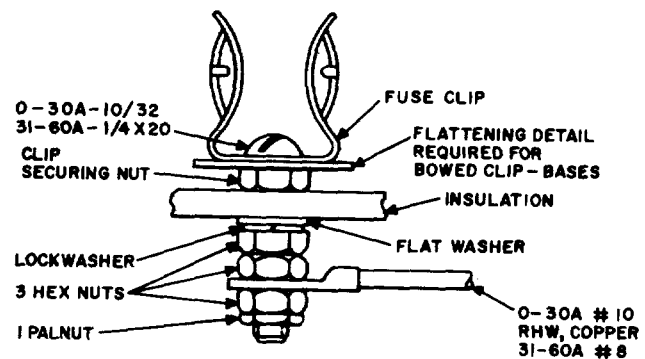

Fig. 18—KS-20521 Typical Mounting Arrangement

**3.15** The KS-21613 fuse clips are used with low-voltage 70-type fuses. The fuse clips are mounted on printed circuit boards. The KS-21613, L1, (Fig. 19) is a battery terminal. The KS-21613, L2, (Fig. 20) is the load terminal, and the KS-21613, L3, (Fig. 21) is the alarm terminal.

**3.16** To replace the fuse clip, proceed as follows:

- (1) Shut the power off.
- (2) Remove the solder from the terminals of the fuse clip.
- (3) Replace with new fuse clips and resolder.
- (4) Turn power on.

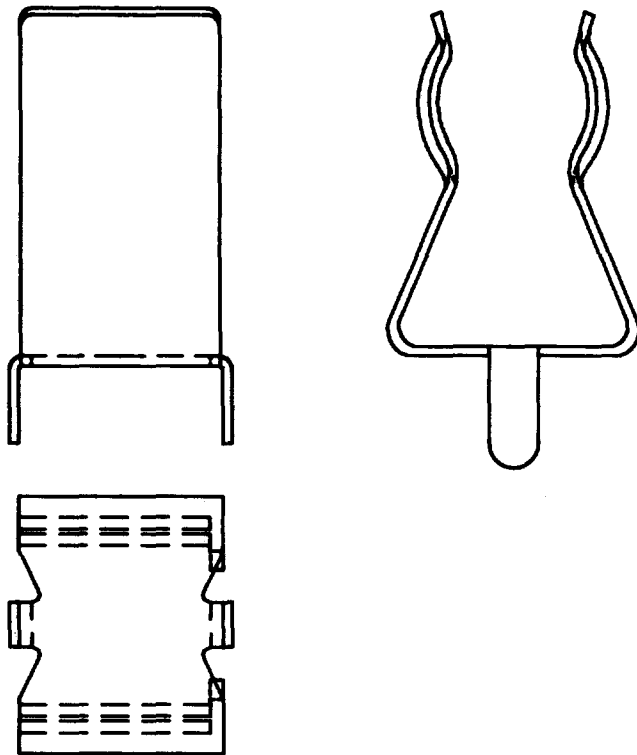

Fig. 19—KS-21613, L1, Fuse Clip (Battery Terminal)

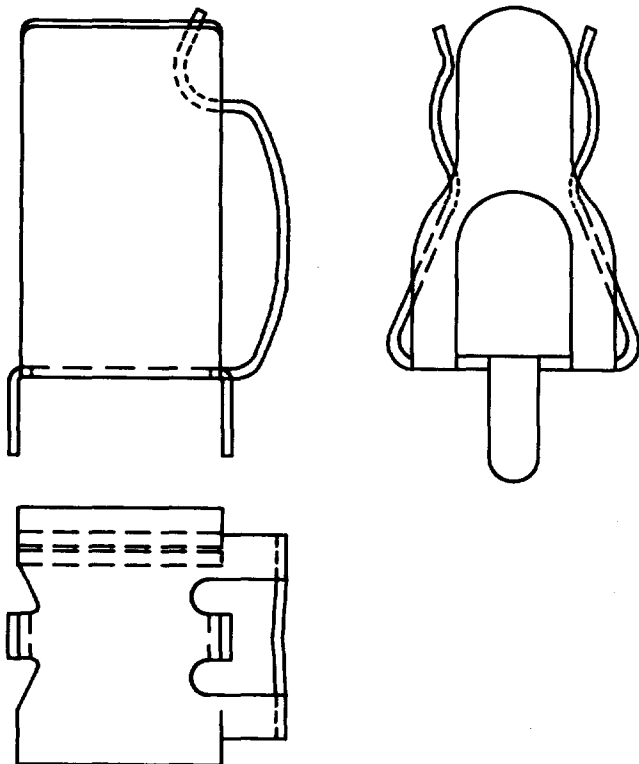

Fig. 20—KS-21613, L2, Fuse Clip (Load Terminal)

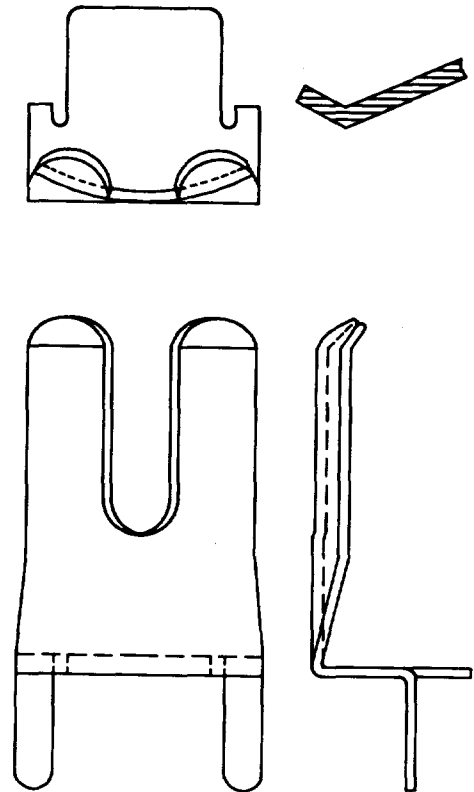

Fig. 21—KS-21613, L3, Fuse Clip (Alarm Terminal)

**G. Fuse Holders, Mountings, Panels, and Posts**

3.17 To replace all fuse holders (except KS-14170, KS-14473, and KS-16364), fuse mountings, fuse panels, and fuse posts (Fig. 22 through 26), proceed as follows:

- (1) Shut the power off.
- (2) **Warning:** When using a soldering iron in the removal of the unit, remove the fuse to prevent heat damage to the fuse. Disconnect the wires from the terminals (note the wire color on each terminal).

**Note 1:** Detailed circuit diagrams, showing terminal functions and position, should be available for reference. Even with circuit and wiring diagram information, each pin should be checked, using a meter on a test probe, prior to initiating work.

**Note 2:** The KS-19393 fuse block and KS-19392 fuse panel are usually bus bar connected and extra care, such as taping exposed bus bars

SECTION 026-370-801

or covering the bus bars with insulating blankets, should be used to prevent accidental short circuits.

- (3) Remove the old unit from the system. Replace it with the new unit.
- (4) Reconnect the wires or bus bar on the terminals.
- (5) Replace the fuse and turn the power on.

◆**Note:** When replacing a link-type fuse on the KS-19392 fuse panel, refer to Section 026-370-701.◆

**3.18** To replace or remove the KS-14170, KS-14473, or KS-16364 fuse holder from their associated fuse block, proceed as follows:

- (1) Place the T bar of the KS-14473, L4, fuse holder puller tool (Fig. 27) over the handle of the fuse holder.
- (2) Place the probes against the top and bottom of the fuse block.
- (3) Grip the T bar and pull toward the handle of the KS-14473, L4, tool to remove the fuse holder.

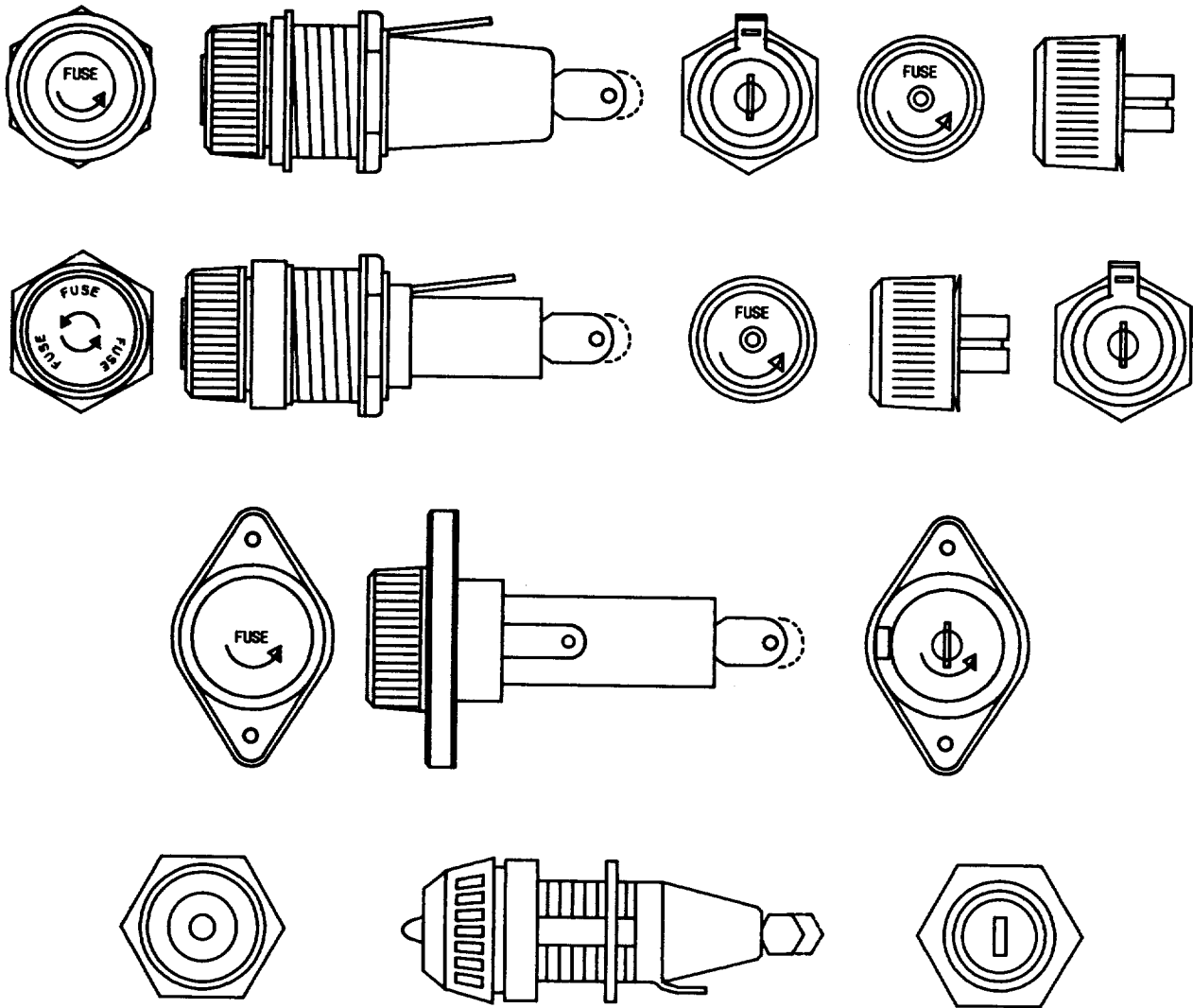

Fig. 22—KS-5842 Fuse Holder

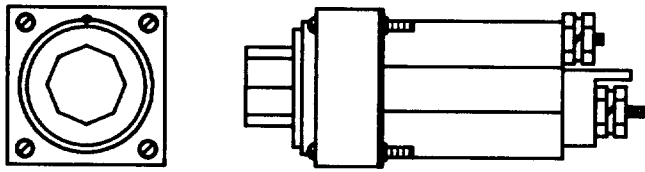
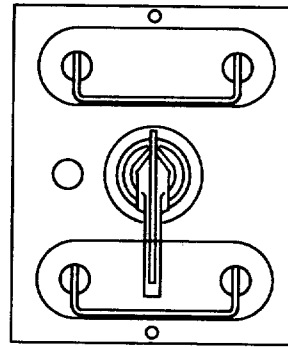
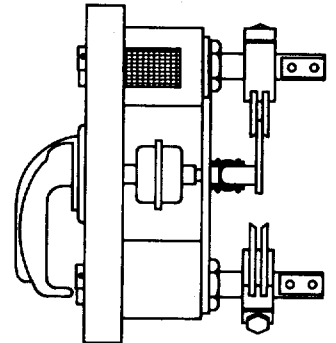

Fig. 23—KS-15715 Fuse Holder



FRONT VIEW



SIDE VIEW

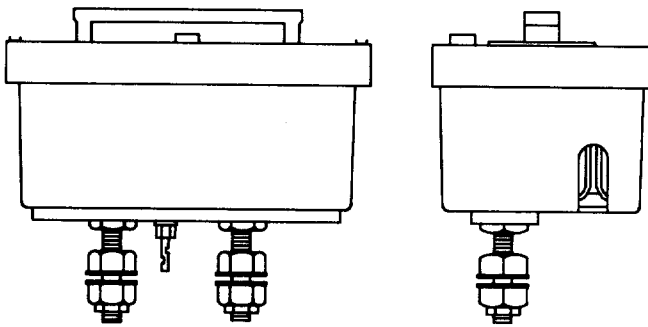
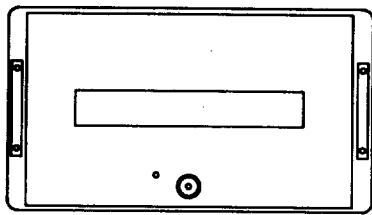
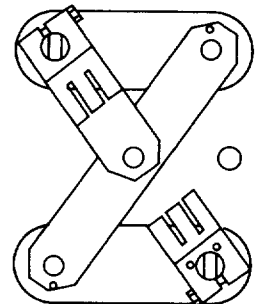

Fig. 24—KS-15858 Fuse Mounting



REAR VIEW TO SHOW TERMINALS

Fig. 25—KS-19392, L2, Fuse Panel

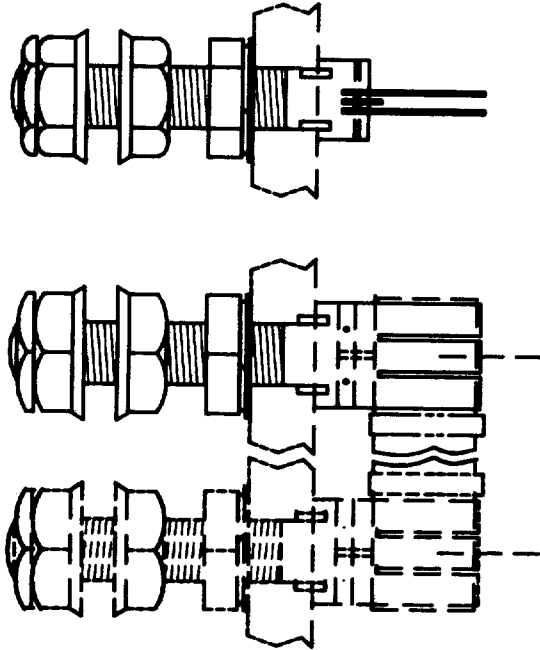

Fig. 26—KS-5083 Fuse Post

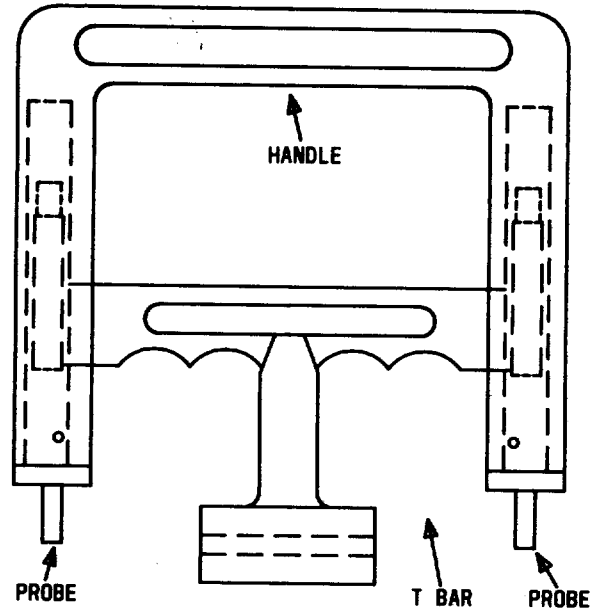

Fig. 27—KS-14473, L4, Fuse Holder Puller Tool