

## KS-15582 STARTER (FOR DC MOTOR) REQUIREMENTS AND ADJUSTING PROCEDURES

### 1. GENERAL

**1.01** This section covers the KS-15582 L1 through L6, motor starters manufactured by the Ward-Leonard Electric Company.

**1.02** This section is reissued to specify the use of KS-19578 L1 trichloroethane instead of KS-8372 trichloroethylene. The same precautions that apply for KS-8372 trichloroethylene shall apply to the KS-19578 L1 trichloroethane.

**1.03** Reference shall be made to Section 020-010-711 covering general requirements and definitions for additional information necessary for the proper application of the requirements listed herein.

**1.04** *Phi* ( $\phi$ ): Requirements are marked with a phi when they are not required to be checked before turnover.

**1.05** *Asterisk* (\*): Requirements are marked with an asterisk when to check for them would necessitate dismantling or dismantling of apparatus, or would affect the adjustment involved, or other adjustments. No check need be made for these requirements unless the apparatus or part is made accessible for other reasons, or its performance indicates that such a check is advisable.

**1.06** For the purpose of this section, contacts are normally open (NO) or normally closed (NC), if the contacts are open or closed, respectively, with no operating current flowing in the coil. NO and NC contacts are sometimes referred to as front and back contacts, respectively.

**1.07** *Operate*: A relay or contactor is said to operate if, when current is connected to its winding, the armature moves sufficiently to meet the following conditions.

- (a) All normally open contacts close and all normally closed contacts open.

- (b) The armature rests against the core or stops.

**1.08** *Release*: A relay or contactor is said to release when the armature has moved sufficiently for NO contacts to open and NC contacts to close with reliable contact.

**1.09** The double-coil AR relay provided on KS-15582 L1, L2, and L3 starters is adjusted and sealed at the factory and is not checked in the field. If this relay is defective, it must be replaced. An improved heavy-duty single-coil AR contactor furnished on KS-15582 L4, L5, and L6 starters can be checked in the field. This contactor is also available for application to lists 1, 2, and 3 starters as follows. Ward-Leonard Kit K-45011 provides for the replacement of the double-coil AR relay with the contactor for the KS-15582 L1 starter and Kit K-45011.1 for the replacement on the KS-15582 L2 and L3 starters.

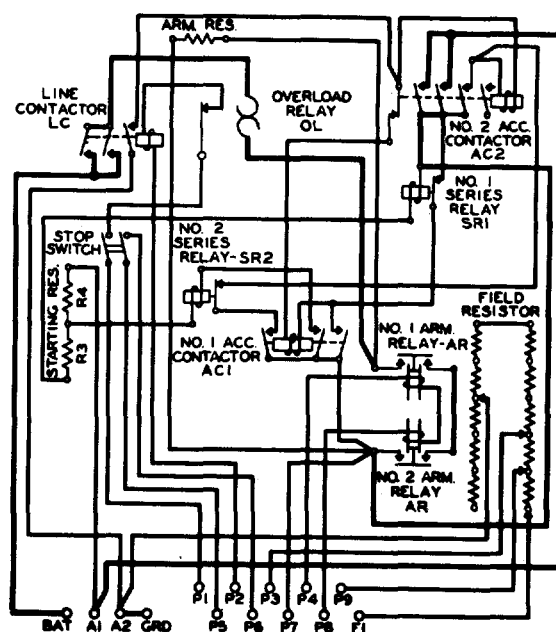

Fig. 1 - Schematic for KS-15582 L1

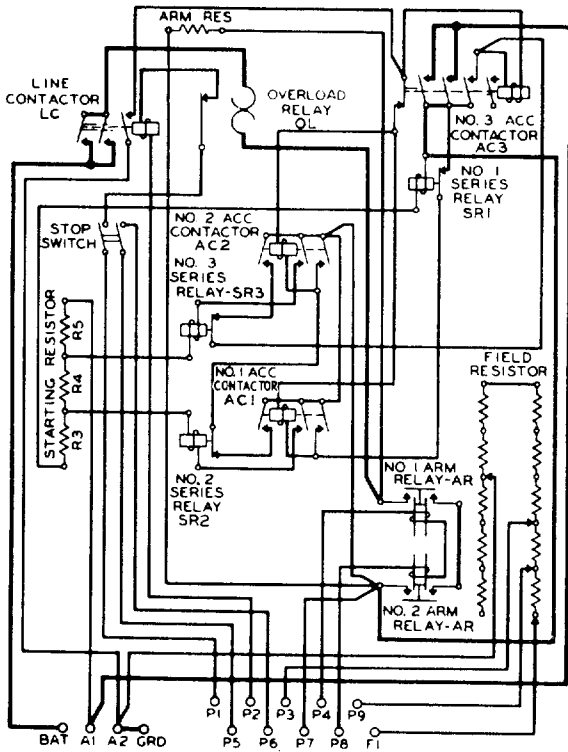

Fig. 2 – Schematic for KS-15582 L2 and L3

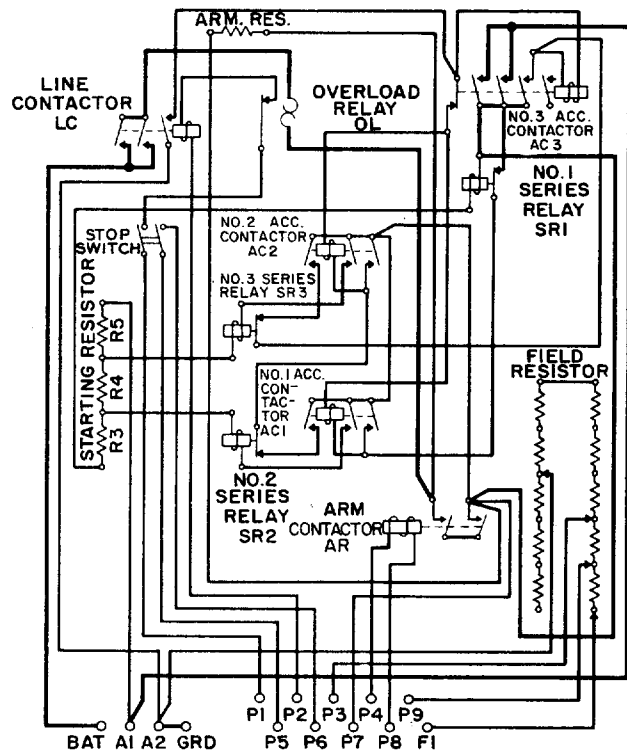

Fig. 4 – Schematic for KS-15582 L5 and L6

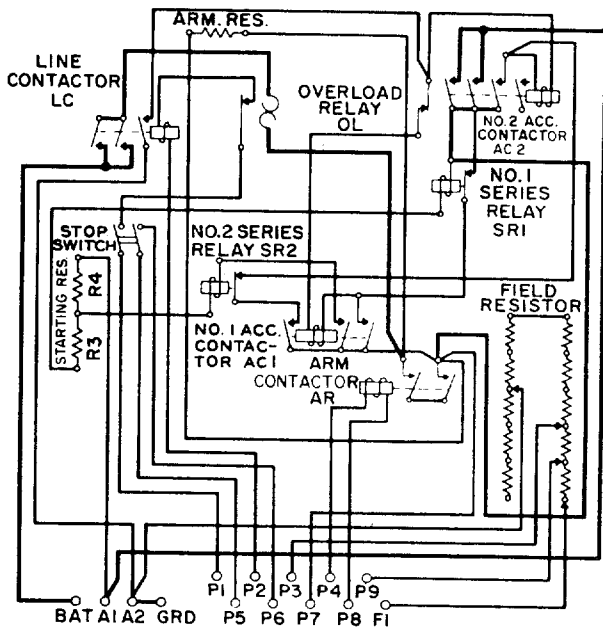

Fig. 3 – Schematic for KS-15582 L4

1.10 When checking requirements or making adjustments, disconnect the relay or contactor from the power supply, if practicable. If this is not practicable, bridge around and insulate the contacts as covered in 3.003. In some cases, it may be necessary to disconnect leads to maintain service.

1.11 *Caution: Use care when working in close quarters with live parts.*

2. REQUIREMENTS

φ2.01 *Cleaning Contacts and Removing Build-ups:* Contacts shall be clean and free from build-ups which might interfere with reliable contact.

Gauge by eye.

φ2.02 *Mounting of Starter and Its Component Parts:* The starter and its component parts shall be mounted securely.

Gauge by feel.

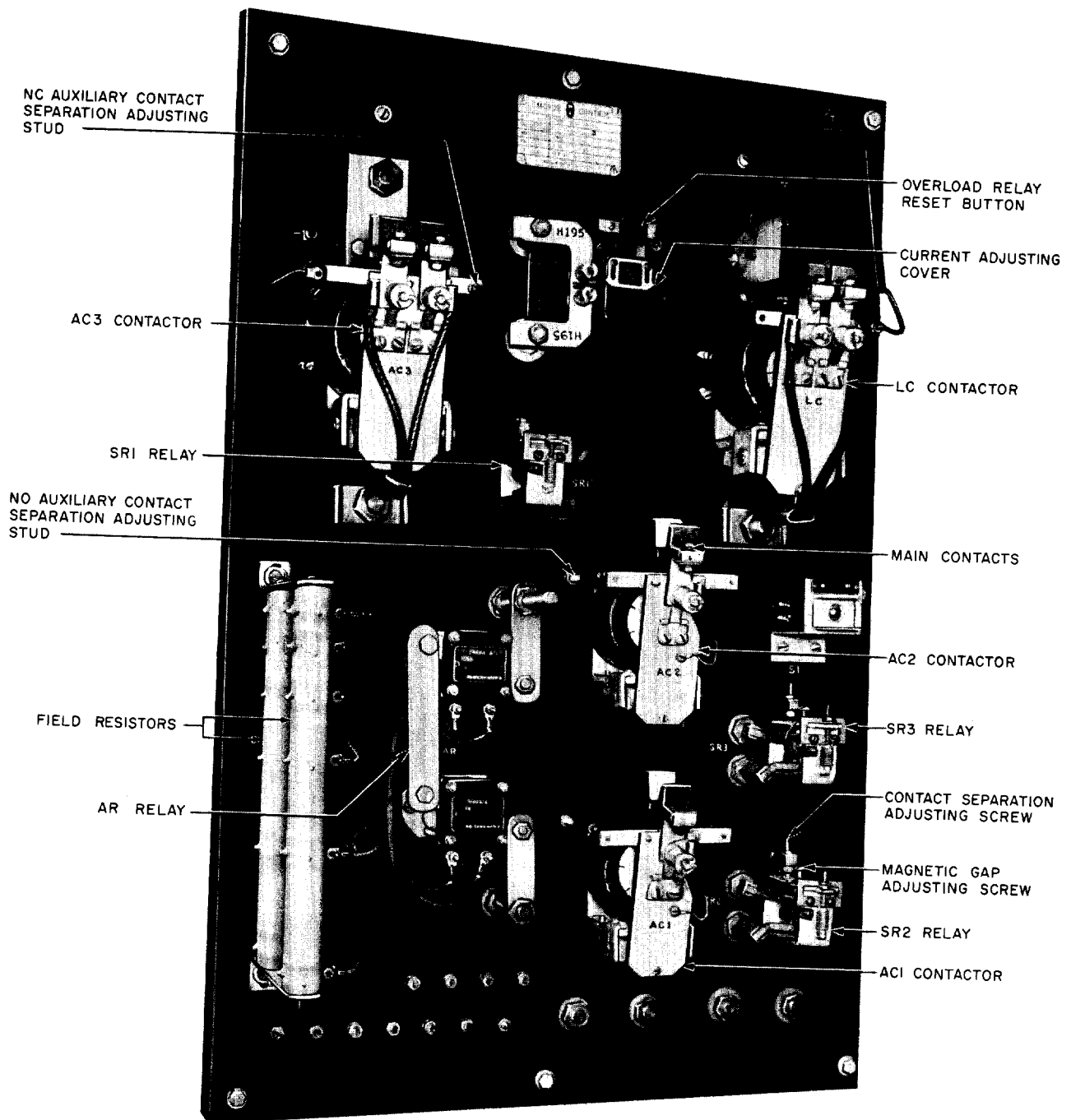

Fig. 5 - KS-15582 L2 Starter

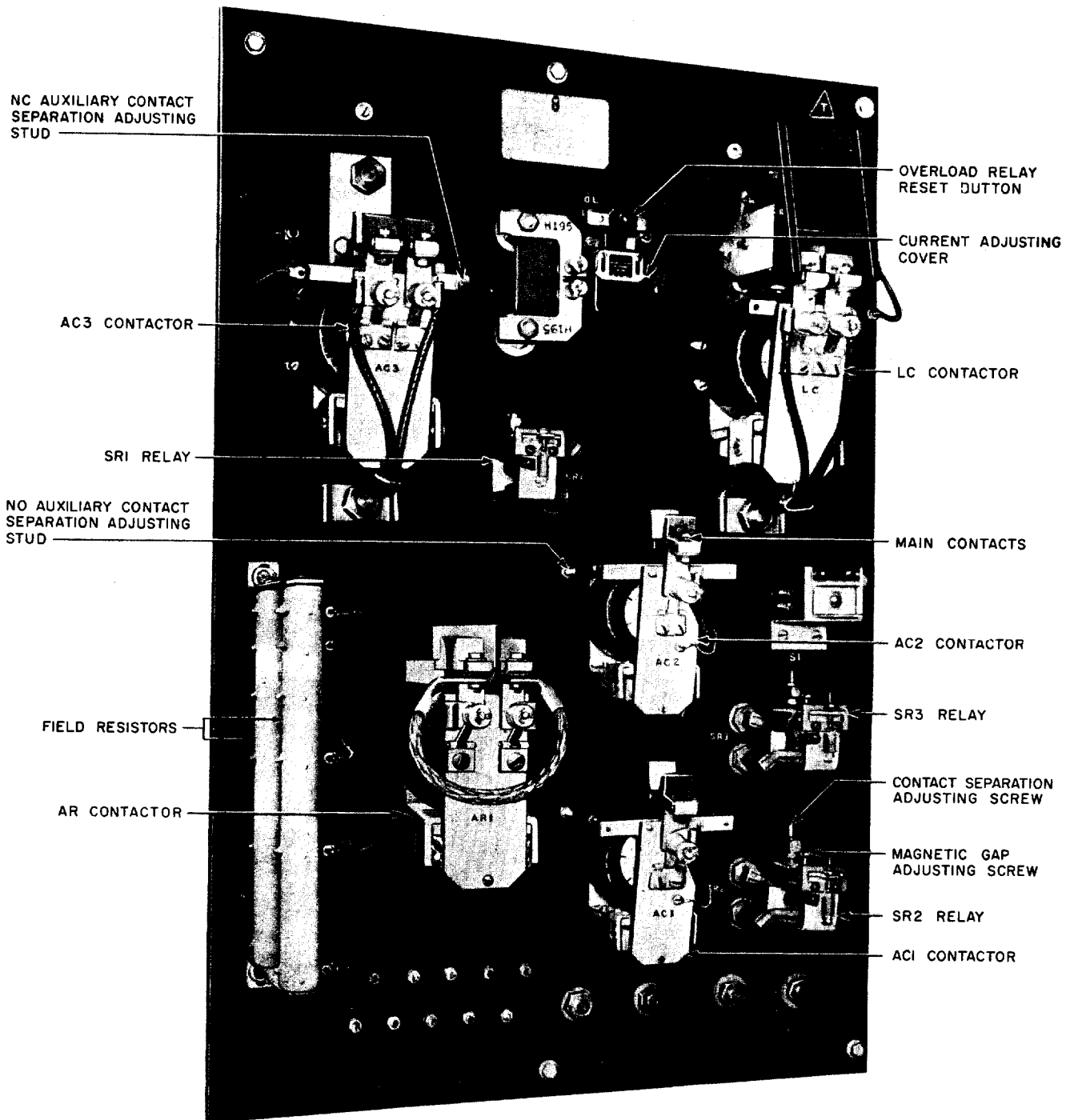

Fig. 6 - KS-15582 L5 Starter

**2.03 Contact Pressure**

(a) The pressure of the main contacts shall be

CONTACTOR DESIGNATION	CONTACT PRESSURE
<b>KS-15582 L1 Starter</b>	
AC1, AC2, and LC	Min 4 pounds
<b>KS-15582 L2 Through L6 Starters</b>	
AC1 and AC2	Min 5 pounds
AC3 and LC	Min 5-1/2 pounds
<b>KS-15582 L4, L5, and L6 Starters</b>	
AR	Min 5 pounds

Use R-2771 spring balance.

To check this requirement, loop a cord around the contact mounting screw, in line with the contact. Engage the loop with the hook of the spring balance and manually hold the armature firmly against the core. Measure the contact pressure just as the contacts open.

**2.04 Contact Separation and Operated Magnetic Gap**

(a) With the contactor in the unoperated position, the separation of NO main contacts shall be

CONTACTOR DESIGNATION	CONTACT SEPARATION
<b>KS-15582 L1 and L4 Starters</b>	
AC1, AC2, and LC	Min 3/4 inch
<b>KS-15582 L2, L3, L5, and L6 Starters</b>	
AC1 and AC2	Min 7/8 inch
AC3 and LC	Min 3/4 inch
<b>KS-15582 L4, L5, and L6 Starters</b>	
AR	Min 1/4 inch

Use R-8550 steel scale.

(b) With the contactor in the unoperated position, the separation of NO auxiliary contacts shall be

CONTACTOR DESIGNATION	CONTACT SEPARATION
<b>KS-15582 L1 and L4 Starters</b>	
AC1, AC2, and LC	Min 1/2 inch
<b>KS-15582 L2, L3, L5, and L6 Starters</b>	
AC1, AC2, AC3, and LC	Min 1/2 inch

Use R-8550 steel scale.

(c) With the contactor in the operated position, the separation of NC auxiliary contacts shall be

CONTACTOR DESIGNATION	CONTACT SEPARATION
<b>KS-15582 L1 and L4 Starters</b>	
AC2	Min 3/16 inch
<b>KS-15582 L2, L3, L5, and L6 Starters</b>	
AC3	Min 3/16 inch

Use R-8550 steel scale.

(d) **SR Relays:** Fig. 7(A) and (B) — With the relay in the operated position, the following requirements shall be met

Contact Separation	Min 0.025 inch
Operated Magnetic Gap	Max 3/16 inch

Use KS-6909 gauge for checking contact separation and R-8550 steel scale for checking operated magnetic gap.

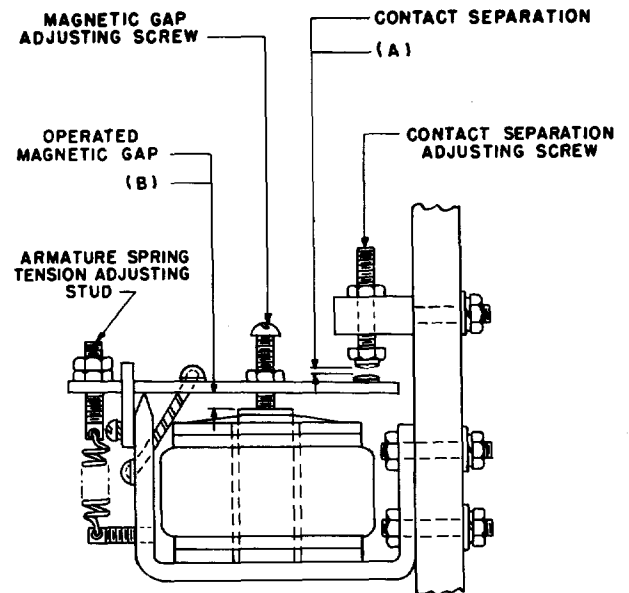

Fig. 7 — SR Relay (shown in operated position)

**2.05 Electrical Requirements**

(a) The relays and contactors shall meet the electrical requirements specified in the circuit requirements table or other job information.

(b) If electrical requirements are not specified on the circuit requirements table, the following requirements shall apply.

(1) **AC and LC Contactors:** The contactors shall operate on

- AC contactors — Min 120 volts
- LC contactors — Min 20 volts

Use 35-type test set.

To check this requirement, use a 35-type test set having a voltmeter. If this test set is not available, use the external voltmeter in conjunction with the test set. If test set preparation is not specified on the circuit requirements table, disconnect the relay from the circuit and furnish battery and ground through the test set with B/G/V preparation.

(2) **SR Relays:** The SR relays shall operate in succession on the motor inrush current, and their NC contacts shall open before their associated AC contactors operate. The SR relays shall meet the following release requirements.

STARTER	SR RELAY RELEASE CURRENT	
	AMPERES	
	MIN	MAX
KS-15582 L1 and L4	135	145
KS-15582 L2 and L5	223	237
KS-15582 L3 and L6	290	310

Use Weston Model 901 ammeter.

To check the operate requirement, start the motor and observe the operation of the SR relays and their associated AC contactors. To check the release requirement, connect the ammeter in series with the SR relay and observe at what point the SR relay releases as the current decreases.

**Note:** 2/0 gauge insulated wire (equipped with KS-5517 L20 lugs) should be used when connecting the ammeter in the circuit.

(3) **OL Relay:** The OL relay shall meet the following operate requirement.

STARTER	OL RELAY OPERATE CURRENT
	AMPERES
KS-15582 L1 and L4	124
KS-15582 L2 and L5	196
KS-15582 L3 and L6	260

Use test circuit as shown in Fig. 8.

To check this requirement, remove the leads from the OL relay coil terminals, and connect the test circuit across these terminals. Adjust the output of the test circuit to the specified operate current value of the relay by varying the autotransformer.

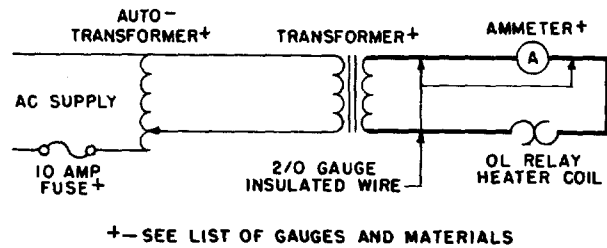

Fig. 8 – Circuit for Checking Operate Current of OL Relay

(c) Check of electrical requirements may be made at the temperature at which the relay or contactor is found unless H (hot) or C (cold) is specified on the circuit requirements table.

(d) If H is specified on the circuit requirements table without heating instructions, the relay or contactor coils shall be energized for at least 1 hour prior to the check. See 3.002.

(e) If C is specified on the circuit requirements table without cooling instructions, the relay or contactor shall be de-energized for at least 2 hours prior to the check. See 3.002.

ϕ2.06 **Temperature:** The temperature shall not exceed

	MAX
Coils and Contacts	105 C (221 F)
Frames and other parts in contact with insulation	95 C (203 F)

Use R-1032 thermometer.

To check this requirement, hold the bulb of the thermometer against the part. Cover the portion of the bulb not in contact with the part with the asbestos pad. Observe the maximum temperature reading.

## 3. ADJUSTING PROCEDURES

3.001 *List of Tools, Gauges, Materials, and Test Apparatus*

CODE OR SPEC NO.	DESCRIPTION	CODE OR SPEC NO.	DESCRIPTION
		<b>GAUGES</b>	
		—	Voltmeter, dc, Weston Model 931, Ranges 300/150/75/30 (if 35-type test set having voltmeter is not available)
		<b>TOOLS</b>	
246	1/2-Inch Open Single-End Flat Wrench		
365 (As reqd)	Connecting Clip	<b>MATERIALS</b>	
373D	Contact Burnisher Holder	108 (As reqd)	Cord Tip
374A	Burnisher Blade	KS-7187	Bond Paper
417A	1/4- and 3/8-Inch Hex. Open Double-End Flat Wrench	KS-19578 L1	Trichloroethane
418A	5/16- and 7/32-Inch Hex. Open Double-End Flat Wrench	KS-14666	Cleaning Cloth
KS-2662	File	—	Abrasive Cloth, 150 Grade
KS-6320	Orange Stick	—	Asbestos Pad
KS-6367	7/16- and 5/8-Inch Open Double-End Flat Wrench	—	1-Ounce Bottle
KS-6780 (As reqd)	Connecting Clip	—	14 Gauge Insulated Wire
KS-6854	Screwdriver	—	2/0 Gauge Insulated Wire (each end equipped with KS-5517 L20 lugs)
KS-14208 (Two reqd)	Brush		
		<b>TEST APPARATUS</b>	
R-3193	9/32- and 11/32-Inch Open Double-End Flat Wrench	35 Type	Test Set
—	5-Inch E Screwdriver	1W13A	Cord (each end equipped with a 365 connecting clip or KS-6278 connecting clip)
		1W13B	Cord (each end equipped with a 365 connecting clip or KS-6278 connecting clip)
		<b>GAUGES</b>	
KS-6909	Gauge		
R-1032, Detail 1	Thermometer (-5 to 150 C)		
R-2771	0- to 6-lb Spring Balance	—	Autotransformer, Continuously Tapped (Variac, 8-amp, 230-volt input, type V-20HM, General Radio Co, Cambridge, Mass., or equivalent)
R-8550	6-Inch Steel Scale		
—	Ammeter, dc, Weston Model 901, With KS-9442, List 6 Shunt for 150-Ampere Range or KS-9442, List 14 Shunt for 1500-Ampere Range	—	Fuse 10-amp, 250 volts

SECTION 026-384-701

CODE OR  
SPEC NO.

DESCRIPTION

TEST APPARATUS

— Transformer, current,  
5:800 amperes, General  
Electric Co, Type JKR-2,  
Cat. No. 416 X515

— Ammeter, AC-DC  
clamp-on Columbia  
Electric Manufacturing  
Co, Type CS with 75, 200,  
and 500-amp scale ranges

**3.002** *Caution: Use care when working in close quarters with live parts.*

**3.003** *Maintaining Service While Working on Relays or Contactors*

(1) **Bridging Contacts:** To maintain service while work is being done affecting closed contacts carrying current in working circuits, bridge the contacts at the most convenient points in the circuit other than at the relay or contactor, if practicable. No. 1W13A cords (3 feet long), 1W13B cords (6 feet long) with KS-6278 connecting clips (jaws insulated with No. 108 cord tips), and 2/0 gauge insulated wire (equipped with KS-5517 L20 lugs) are satisfactory for strapping purposes. Lengths of 14 gauge insulated wire, or flexible cord such as is commonly used in lighting circuits, with KS-6780 connecting tips (jaws insulated with No. 108 insulated tips) are also satisfactory.

(2) **Insulated Contacts and Parts:** KS-7187 bond paper should be used for insulating live parts, including open contacts, and should be shaped or bent as necessary to provide protection with the minimum interference to the work being done.

**3.01** *Cleaning Contacts and Removing Build-ups* (Reqt 2.01)

(1) **Cleaning Contacts:** The purpose of cleaning contacts is to remove any gummy or dirty substance that would interfere with reliable contact. It is not necessary or desirable to keep contacts polished or shining. Clean contacts with KS-19578 L1 trichloroethane as covered in (a) and (b) and then brush them with a dry, clean KS-14208 brush as covered

in (c). If necessary, burnish the contacts as covered in (d).

→ (a) Pour a small quantity of the trichloroethane into a 1-ounce bottle. It is important to avoid the use of contaminated trichloroethane in cleaning the contacts. Therefore, discard the trichloroethane as soon as it appears dirty.

→ (b) Dip the hairs of a clean KS-14208 brush full length into the trichloroethane. Remove excess fluid by wiping the brush on the edge of the bottle. Then, with the contacts open, brush the entire surface of the contact to be cleaned with the moist brush.

(c) Brush the contacts with a dry, clean KS-14208 brush.

(d) To burnish contacts, insert the 374A burnisher blade held in the 373D contact burnisher holder between the contacts. If the contacts are normally open, press them together by holding the armature firmly against the pole face with the KS-6320 orange stick. Move the burnisher blade back and forth until the contacts are clean as determined by visual inspection. After burnishing, brush the contacts as covered in (c).

(2) **Removing Build-ups**

(a) To remove build-ups in dead circuits, use a strip of 150 grade abrasive cloth or the KS-2662 file. For contacts in live circuits, use the abrasive paper only.

(b) Insert the abrasive cloth or file between the contacts. Draw the cloth or file back and forth until the build-ups are removed. Exercise care to avoid reducing the height of the contact. After removing build-ups, brush the contacts with a dry, clean KS-14208 brush.

**3.02** *Mounting of Starter and Its Component Parts* (Reqt 2.02)

(1) Tighten all loose screws and nuts using the screwdriver or wrench required.

**3.03** *Contact Pressure* (Reqt 2.03)

(1) No adjustment can be made for contact pressure on these contactors. If the requirement is not met, replace the contact or spring as required.



**Note:** The contact pressure will fall below the minimum value only as a result of excessive wear or filing of the contacts, or weakening of the pressure spring.

### 3.04 *Contact Separation and Operated Magnetic Gap* (Reqt 2.04)

- (1) If the separation of the main contacts on the AC, LC, or AR contactor is less than the minimum specified, check the contactor for obstructions which prevent it from fully releasing. Remove any obstructions. No adjustment can be made for separation on these contactors, and if the requirement can not be met replace the contactor.
- (2) To adjust the separation of NO auxiliary contacts of AC and LC contactors, loosen the nut on the stationary stud. Position the stud to meet the requirement, by turning the stud in the nuts. Securely tighten the nuts.
- (3) To adjust the separation of NC auxiliary contacts of the AC2 contactor on the KS-15582 L1 and L4 starters or the AC3 contactor on the KS-15582 L2, L3, L5, and L6 starters proceed as follows. Loosen the nuts on the armature stud. Position the stud to meet the requirement by turning the stud in the nuts. Securely tighten the nuts.
- (4) To adjust the contact separation and operated magnetic gap on the SR relay, hold the relay operated. Loosen the nut on the magnetic gap adjusting screw. Position the screw to the maximum requirement by turning the

screw in the armature. Securely tighten the nut. After adjusting the magnetic gap, loosen the nut on the contact separation adjusting screw. Position the screw to meet the minimum requirement by turning the screw in its support. Securely tighten the nut.

### 3.05 *Electrical Requirements* (Reqt 2.05)

- (1) **AC and LC Contactors:** If the requirement is not met, replace the contactor.
- (2) **SR Relays:** If the SR relay operates too slowly, decrease the armature spring tension as follows. Loosen the spring tension adjusting stud locknut. Turn both nuts nearer the outer end of the stud and securely tighten the locknut. Increasing the armature spring tension or the contact separation will increase the operating time. To increase or decrease the release current, increase or decrease the operated magnetic gap.
- (3) **OL Relay:** To adjust the OL relay, loosen the screws which hold the cover in place. To increase or decrease the operate current, lower or raise the cover. Securely tighten the screws.

### 3.06 *Temperature* (Reqt 2.06)

- (1) If the temperature exceeds the specified limit, check that requirements 2.02, 2.03, and 2.05 are met. If these requirements are met and the temperature is still above the specified limit, refer the matter to the supervisor.