

*BSP # 788B*

**CALCULAGRAPHS**  
**MODELS 6 AND 30**  
**PIECE-PART DATA AND REPLACEMENT PROCEDURES**

**1. GENERAL**

**1.01** This section covers the information necessary for ordering parts to be used in the maintenance of Model 6 and 30 Calculagraphs. It also covers approved procedures for replacing these parts.

**1.02** This section is reissued to revise the piece-part data for the ticket plate.

**1.03** Part 2 of this section covers the piece-part numbers and the corresponding names of the parts which it is practicable to replace in the field in the maintenance of the above apparatus. No attempt should be made to replace parts not designated. Part 2 also contains explanatory figures showing the different parts. This information is called Piece-part Data.

**1.04** Part 3 of this section covers the approved procedures for the replacement of the parts covered in Part 2. This information is called Replacement Procedures.

**2. PIECE-PART DATA**

**2.01** The figures included in this part show the construction of the apparatus and the

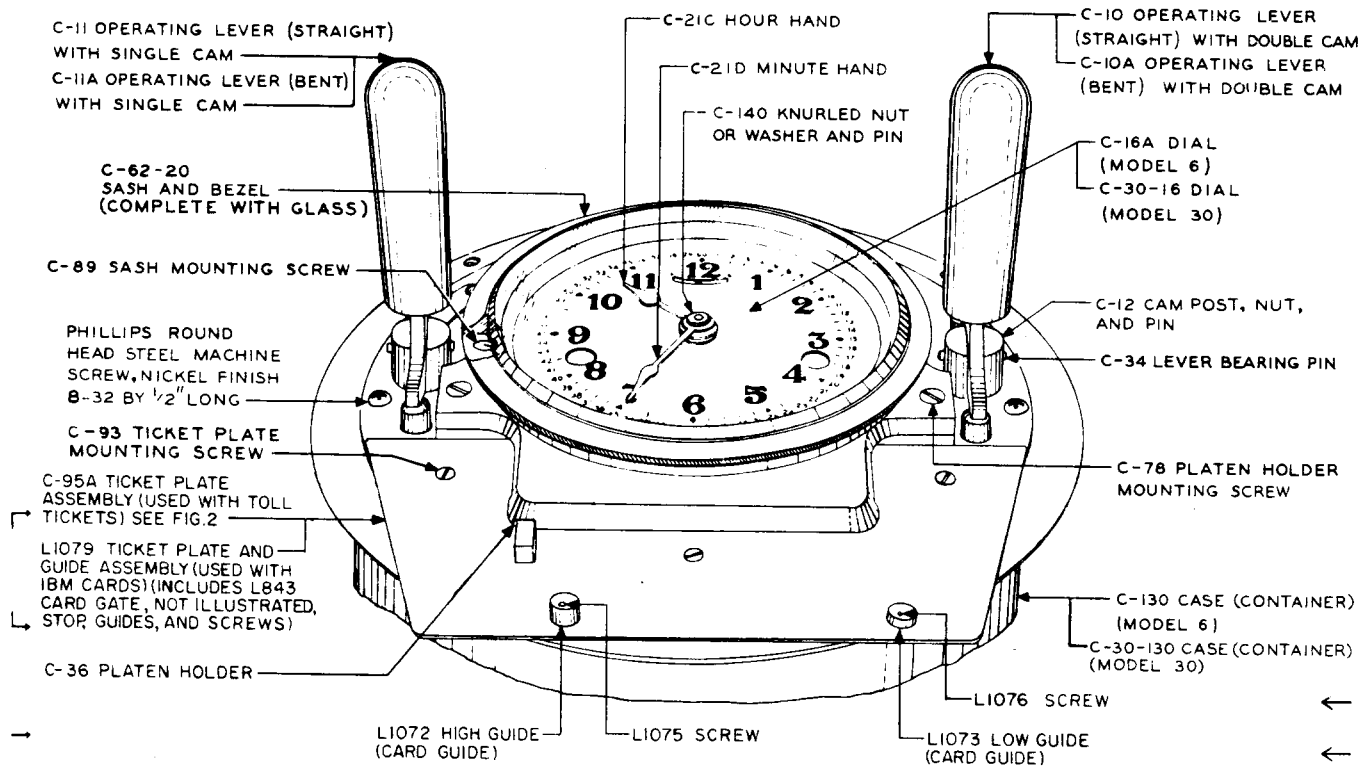
piece-part numbers of the various parts together with their corresponding names.

**2.02** When ordering piece parts for replacement purposes, give both the number and the name of the piece part and also specify that the part is for the Model 6 or 30 Calculagraph, for example, C-35 Platen for Model 6 Calculagraph. When ordering pins to secure the various wheels, shafts, or pinions, order C-138 Pins, Tapered, Assorted, for Model 6 Calculagraph. When ordering washers, order Washers, Assorted, for Model 6 Calculagraph. The piece-part designations and numbers specified in this section are those assigned by the Calculagraph Company. Do not refer to the BSP number.

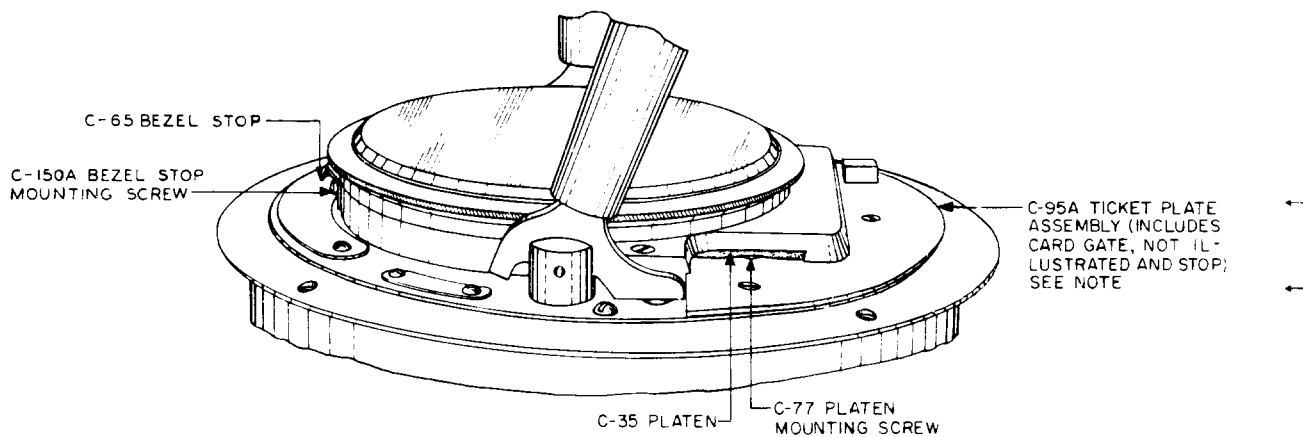
**2.03** Information enclosed by parentheses ( ) is not ordering information. This information may be references to notes, parts referred to in other portions of the section and not considered replaceable, or part names in general use in the field if these names differ from those assigned by the manufacturer.

**2.04** The following figures show the variable piece parts as well as the parts which are common to both types of Calculagraphs.

**SECTION 030-100-801**

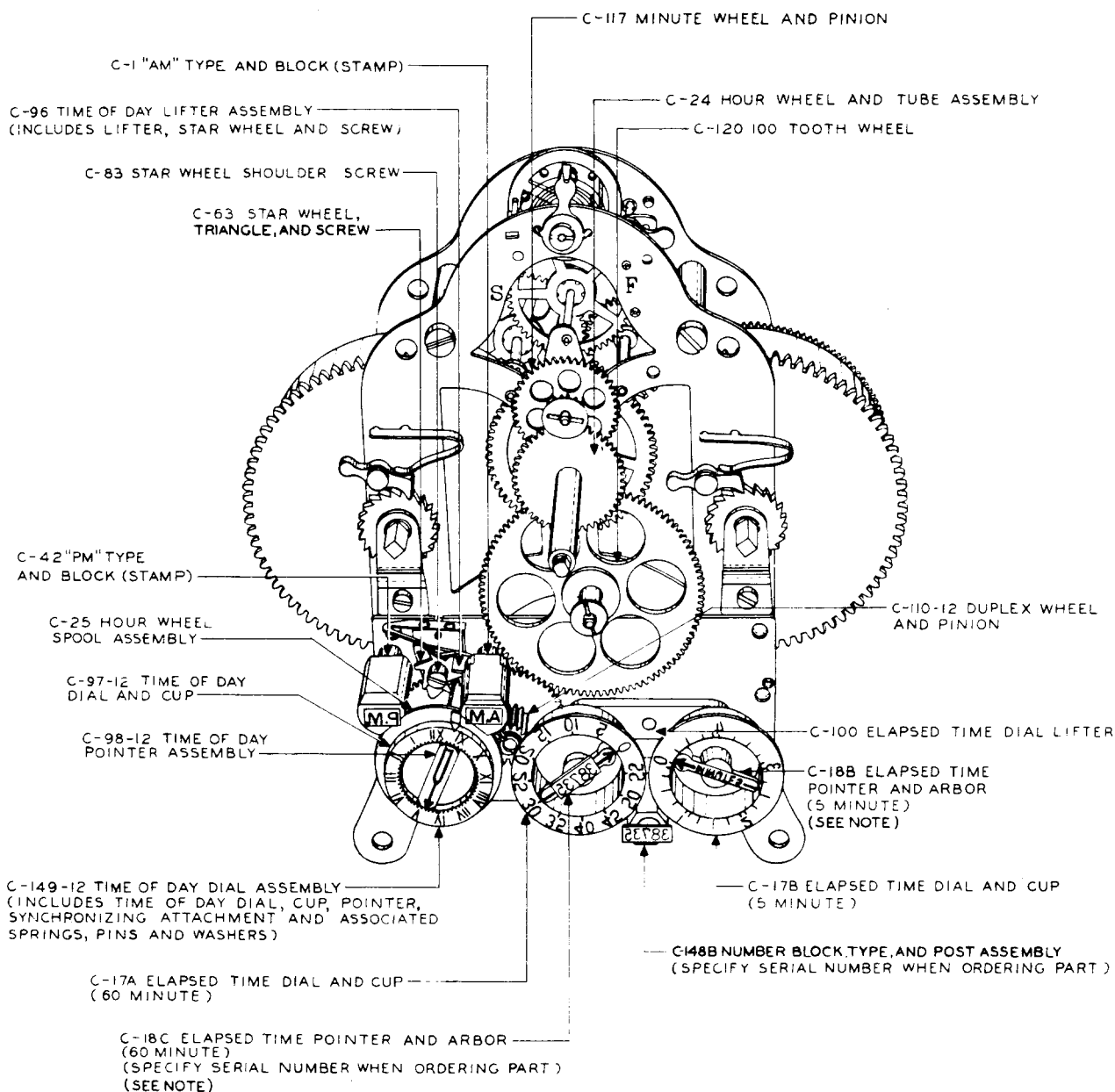


**Fig. 1 - Top View of Calculagraph**



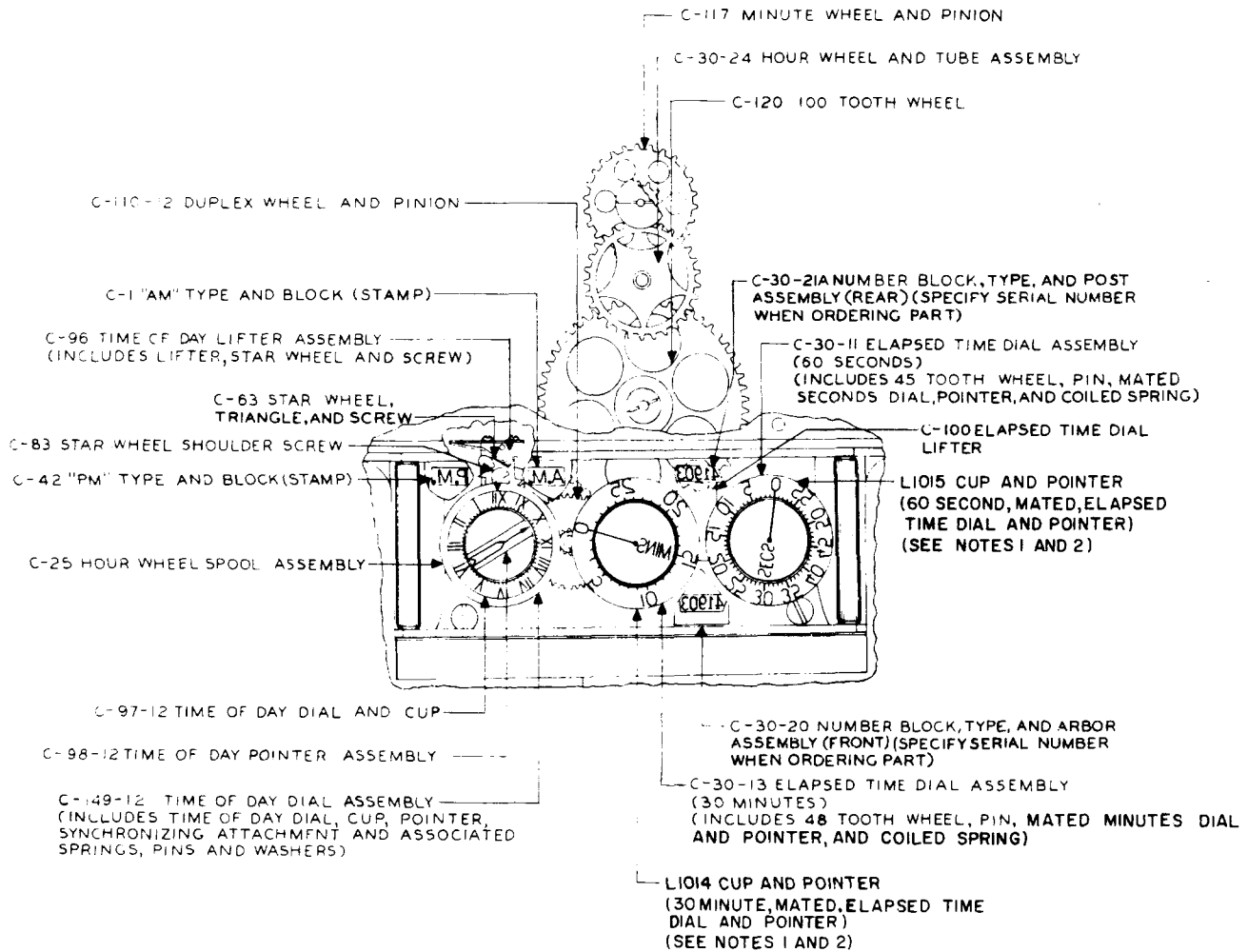
NOTE:  
 EARLIER TICKET PLATE ASSEMBLIES WERE EQUIPPED WITH CARD GATES WHICH HAD STRAIGHT EDGES. LATER TICKET PLATE ASSEMBLIES ARE EQUIPPED WITH L843 CARD GATES WHICH HAVE A SCALLOPED EDGE ON THE SIDE NEAREST THE RIBBON. WHEN REPLACING EITHER GATE ORDER L843 CARD GATE.

**Fig. 2 - Side View of Calculagraph**



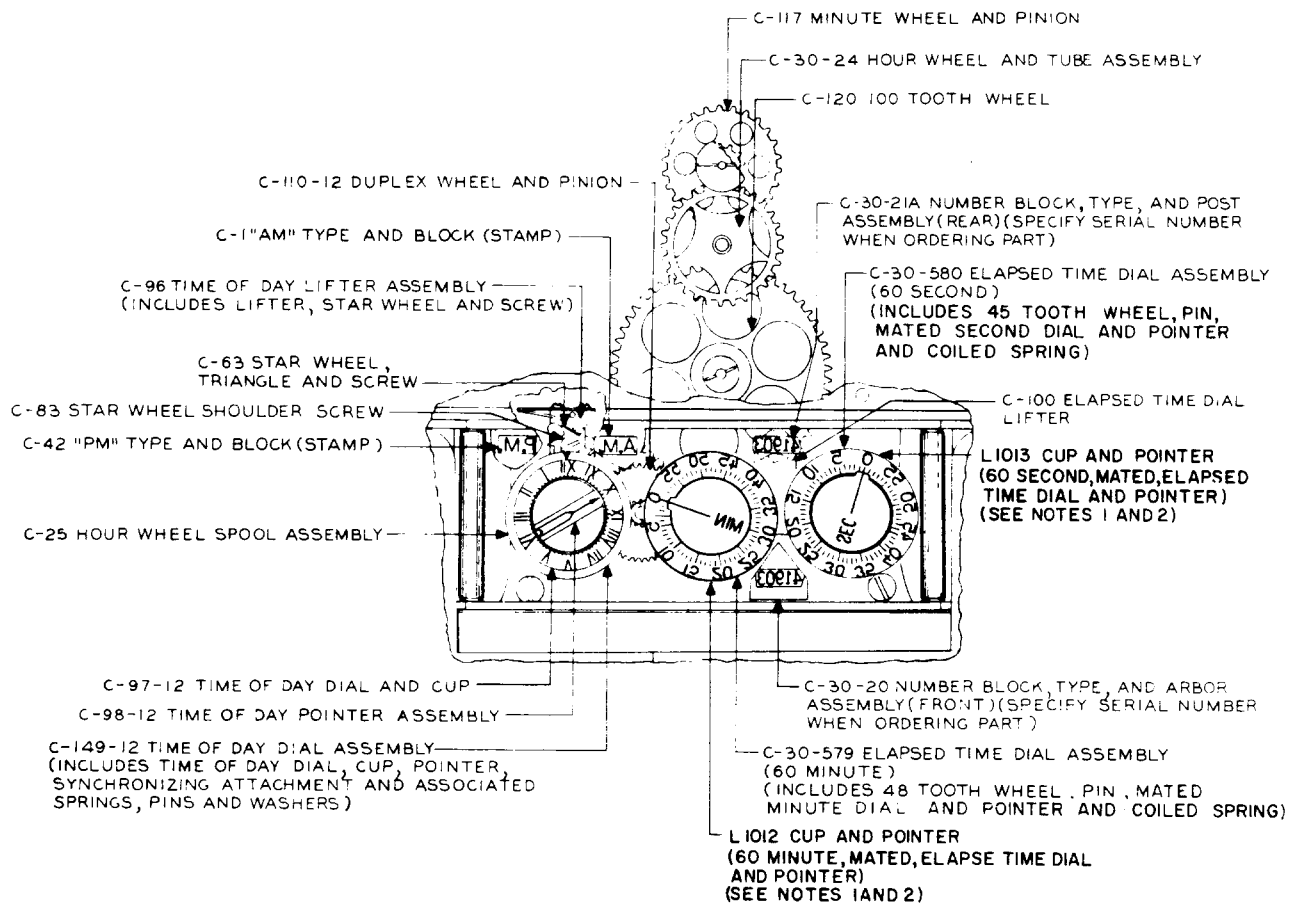
NOTE: WHEN ORDERING THE POINTER ASSEMBLY, ORDER A POINTER ARBOR COILED SPRING (SEE FIG. 7) AND PINS AS REQUIRED WHEN THE CALCULAGRAPH IS EQUIPPED WITH A POINTER ARBOR FLAT SPRING.

**Fig. 3 — Clock Movement and Dials — Model 6 Calculagraph Equipped With 12-Hour Time-of-Day Dial**



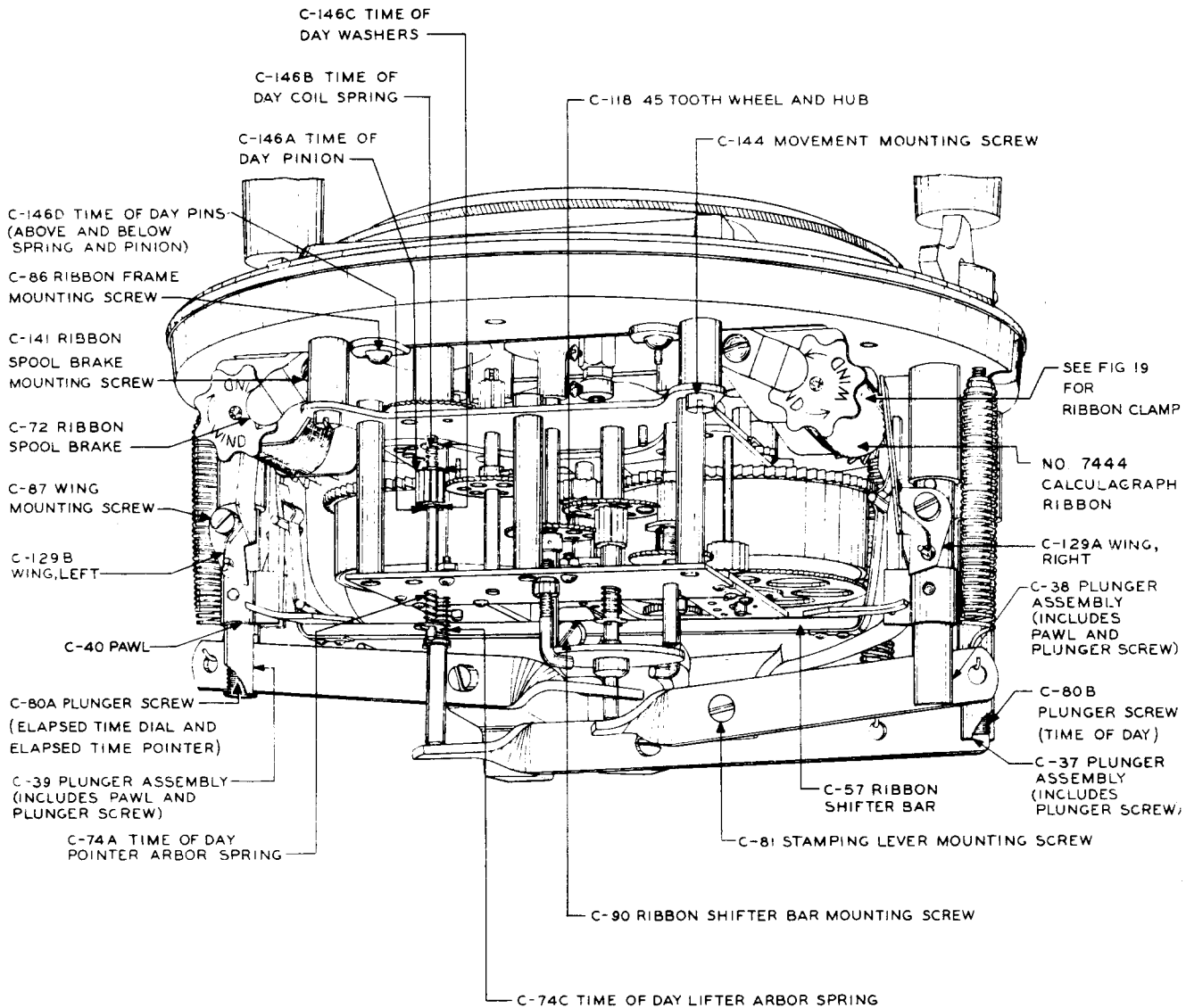
NOTES: 1 WHEN ORDERING THE CUP AND POINTER, ORDER A POINTER ARBOR COILED SPRING (SEE FIG. 8) AND PINS AS REQUIRED WHEN THE CALCULAGRAPH IS EQUIPPED WITH A POINTER ARBOR FLAT SPRING.  
 2 WHEN REPLACING EITHER CUP OR POINTER REPLACE BOTH PARTS.

**Fig. 4 — Clock Movement and Dials — Model 30 Calculagraph Equipped With 12-Hour Time-of-Day Dial and 30-Minute Elapsed-Time Dial**



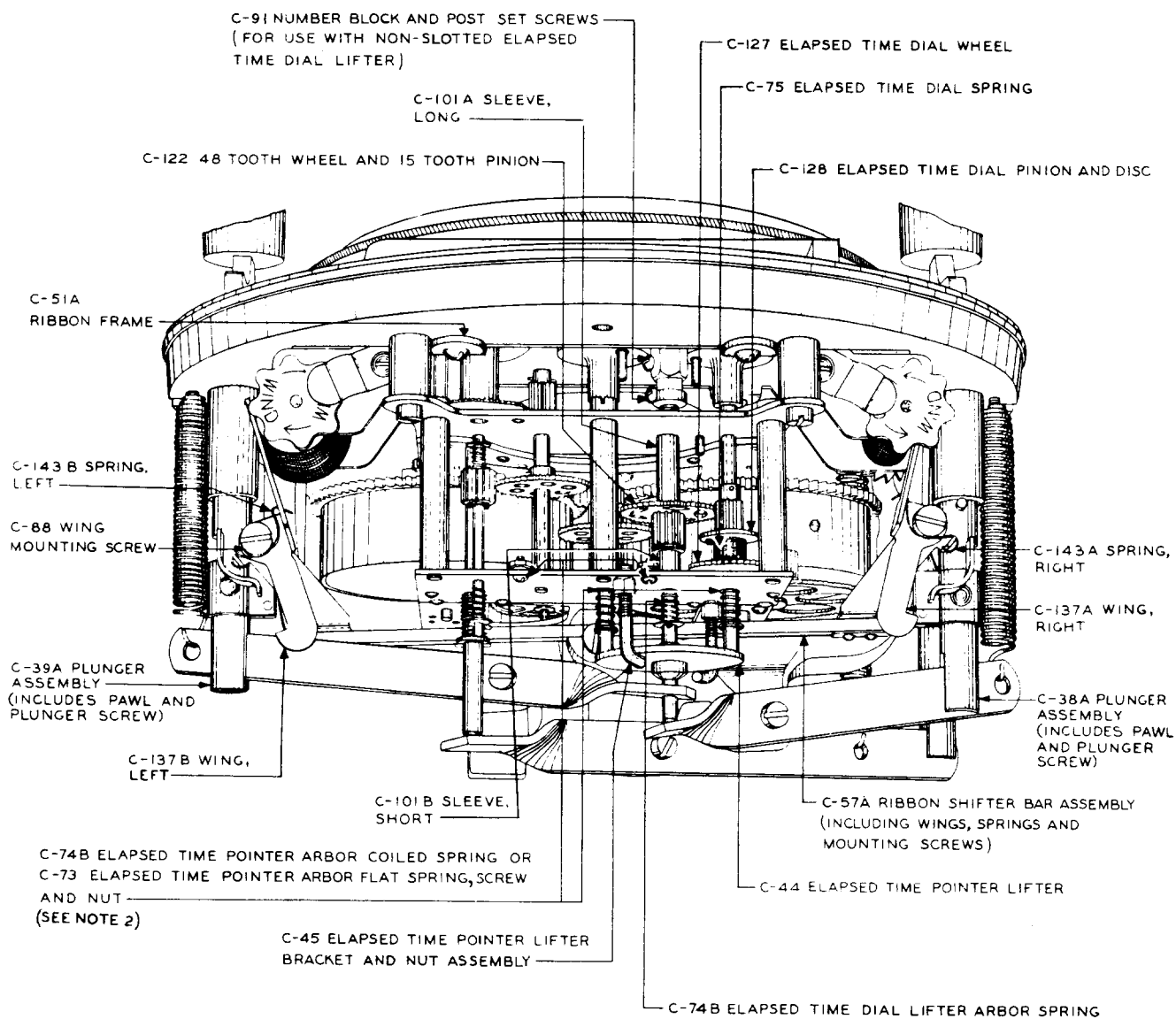
NOTES: 1. WHEN ORDERING THE CUP AND POINTER, ORDER A POINTER ARBOR COILED SPRING (SEE FIG 8) AND PINS AS REQUIRED WHEN THE CALCULAGRAPH IS EQUIPPED WITH A POINTER ARBOR FLAT SPRING.  
 2. WHEN REPLACING EITHER CUP OR POINTER REPLACE BOTH PARTS.

**Fig. 5 – Clock Movement and Dials — Model 30 Calculagraph Equipped With 12-Hour Time-of-Day Dial and 60-Minute Elapsed-Time Dial**



NOTE: THE PARTS SHOWN ON THIS FIGURE, WITH THE EXCEPTION OF THOSE ASSOCIATED WITH THE REVERSING MECHANISM, ARE COMMON TO MODEL 6 CALCULAGRAPHS EQUIPPED WITH EITHER THE FULL SPOOL OR UNWOUND SPOOL RIBBON REVERSE MECHANISM. REPLACEABLE PARTS NOT DESIGNATED ON THIS FIGURE ARE DESIGNATED ON FIG 7

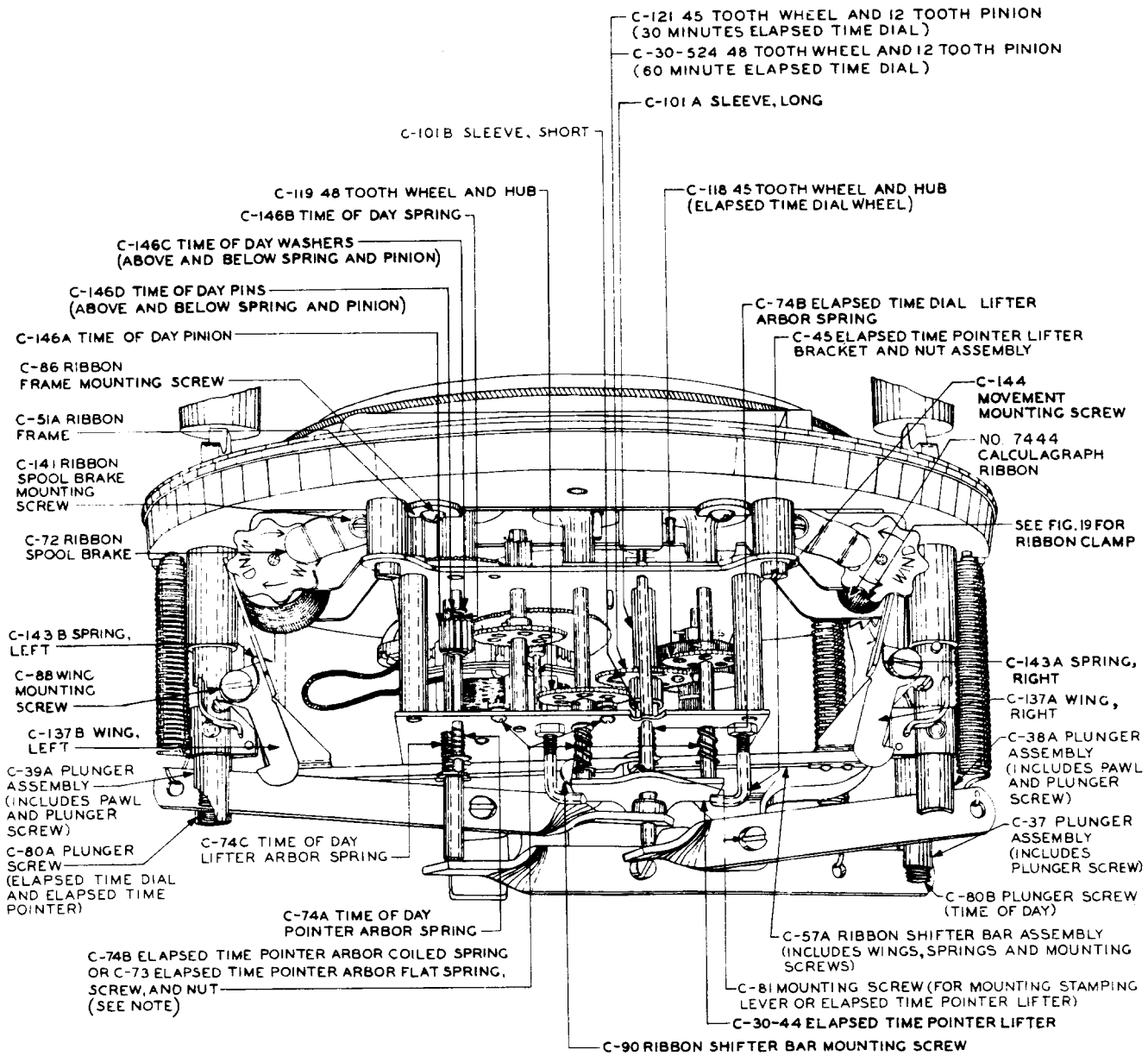
**Fig. 6 – Model 6 Calculagraph Equipped With Full Spool Ribbon Reverse Mechanism and 12-Hour Time-of-Day Dial**



NOTE 1 THE PARTS SHOWN ON THIS FIGURE, WITH THE EXCEPTION OF THOSE ASSOCIATED WITH THE REVERSING MECHANISM, ARE COMMON TO MODEL 6 CALCULAGRAPHS EQUIPPED WITH EITHER THE FULL SPOOL OR UNWOUND SPOOL RIBBON REVERSE MECHANISM. REPLACEABLE PARTS NOT DESIGNATED ON THIS FIGURE ARE DESIGNATED ON FIG 6.

2 WHERE A CALCULAGRAPH IS EQUIPPED WITH A COILED SPRING ORDER A C-74B ELAPSED TIME POINTER ARBOR COILED SPRING. WHERE A CALCULAGRAPH IS EQUIPPED WITH A FLAT SPRING ORDER A C-73 ELAPSED TIME POINTER ARBOR FLAT SPRING, SCREW, AND NUT. SEE FIG 3 FOR ORDERING THE SPRING WHEN ORDERING A POINTER ASSEMBLY FOR A CALCULAGRAPH EQUIPPED WITH A FLAT SPRING.

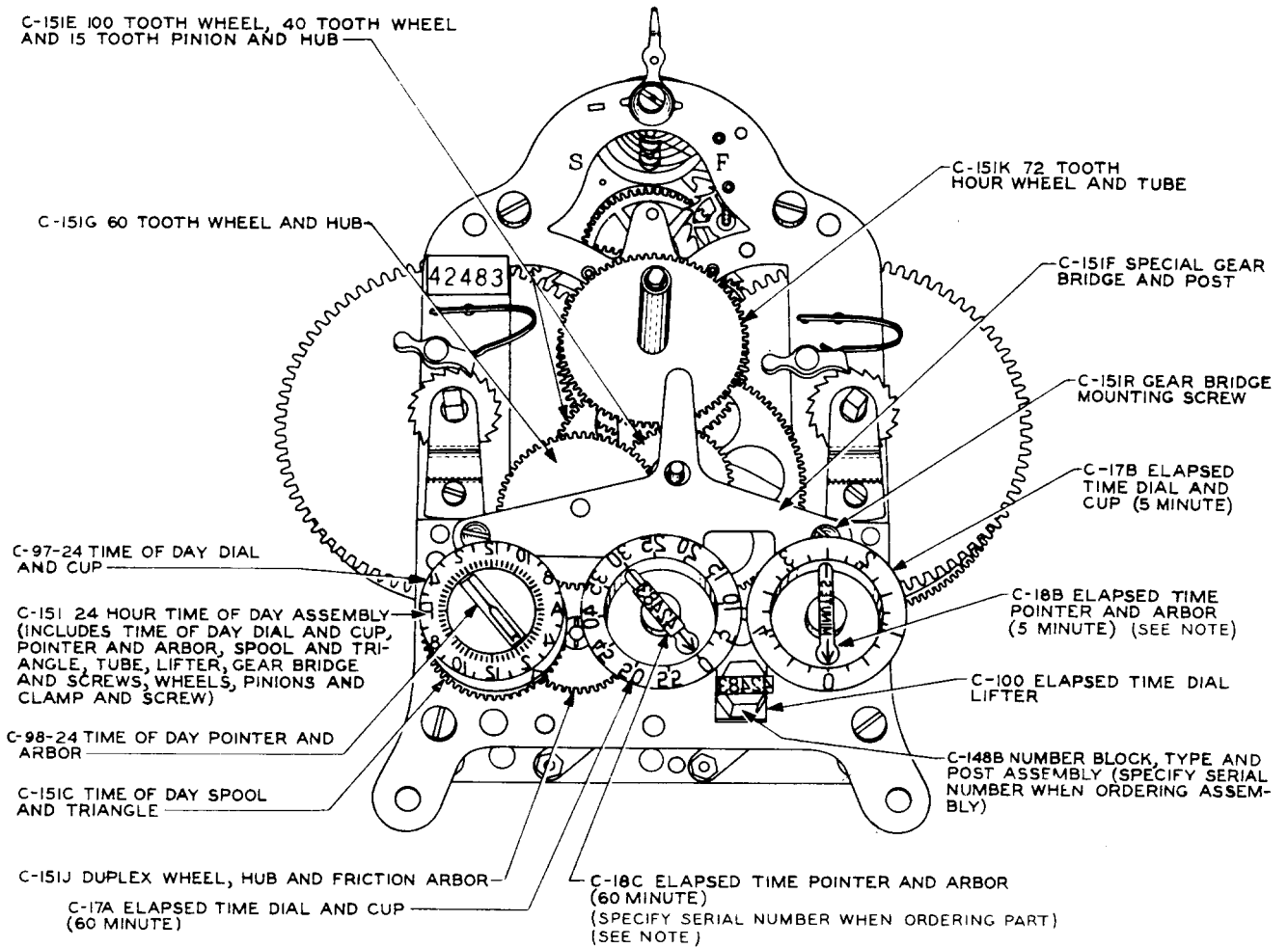
**Fig. 7 – Model 6 Calculagraph Equipped With Unwound Spool Ribbon Reverse Mechanism and 12-Hour Time-of-Day Dial**



NOTE: WHERE A CALCULAGRAPH IS EQUIPPED WITH A COILED SPRING  
ORDER A C-74B ELAPSED TIME POINTER ARBOR COILED SPRING.  
WHERE A CALCULAGRAPH IS EQUIPPED WITH A FLAT SPRING  
ORDER A C-73 ELAPSED TIME POINTER ARBOR FLAT SPRING,  
SCREW AND NUT. SEE FIG. 4 FOR ORDERING THE SPRING WHEN  
ORDERING A POINTER ASSEMBLY FOR A CALCULAGRAPH  
EQUIPPED WITH A FLAT SPRING.

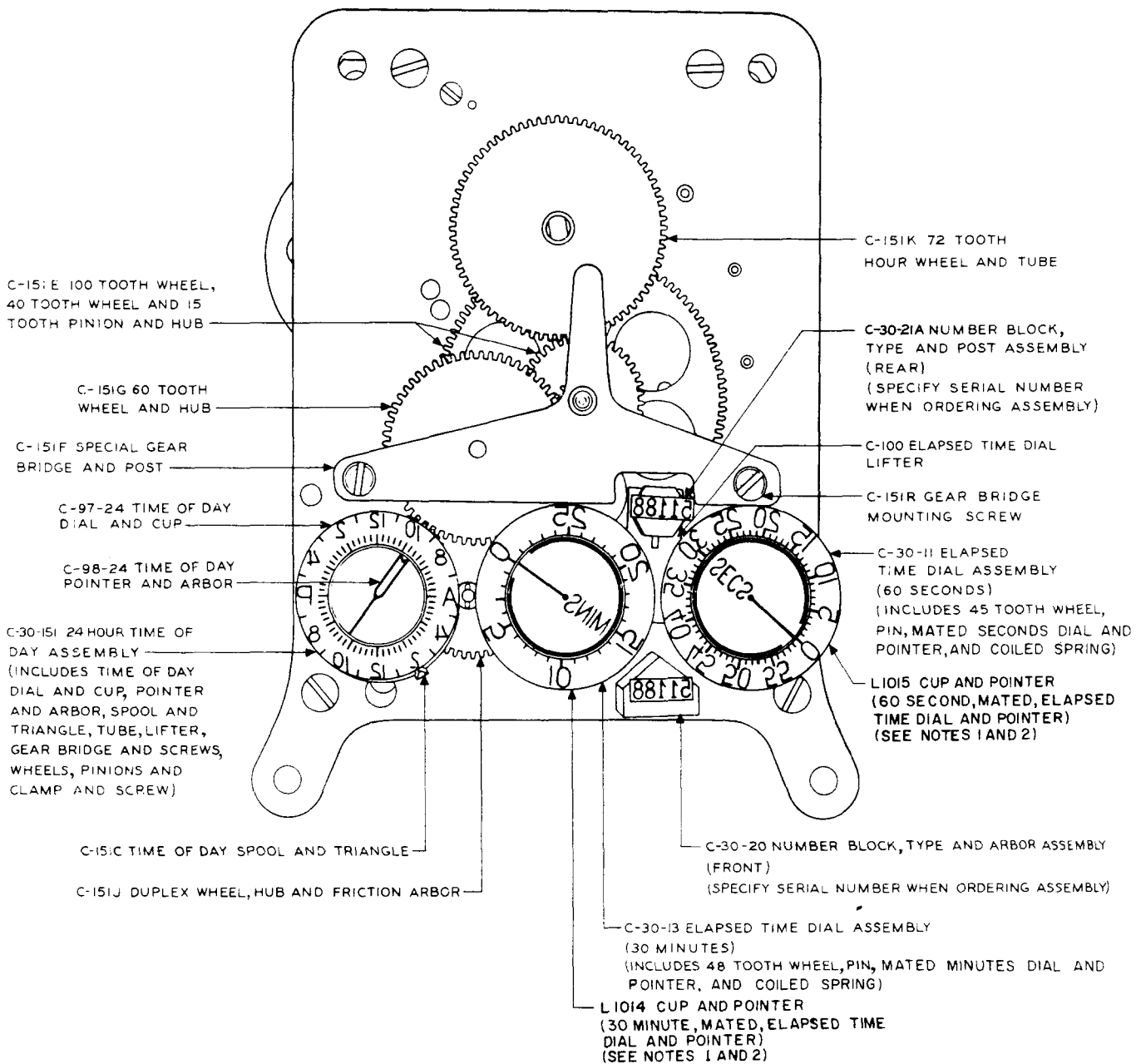
**Fig. 8 – Model 30 Calculagraph Equipped With Unwound Spool Ribbon Reverse Mechanism and 12-Hour Time-of-Day Dial (See Fig. 6 for Parts of Full Spool Ribbon Reverse Mechanism)**





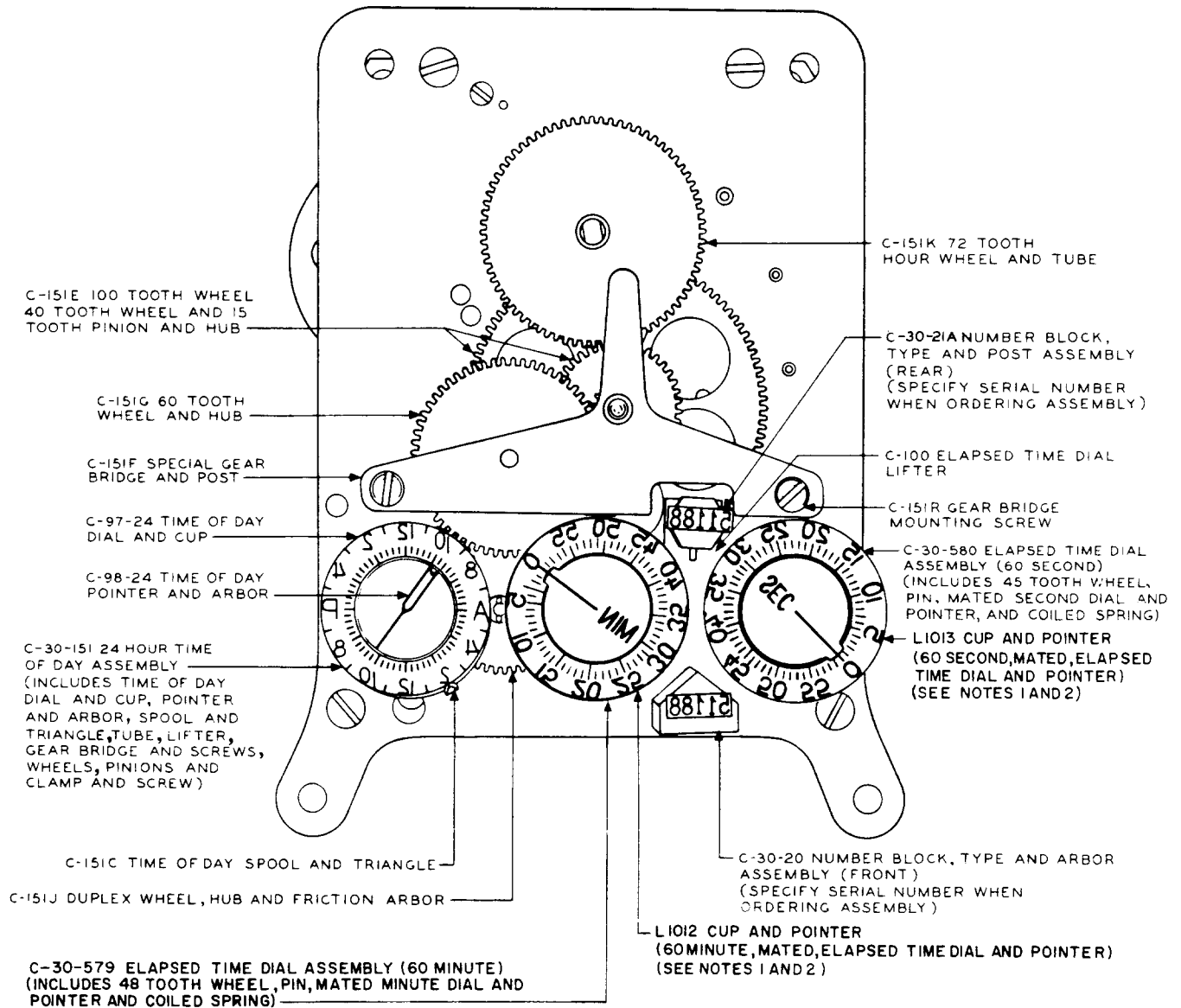
NOTE: WHEN ORDERING THE POINTER ASSEMBLY, ORDER A POINTER ARBOR COILED SPRING (SEE FIG. 13) AND PINS AS REQUIRED WHEN THE CALCULAGRAPH IS EQUIPPED WITH A POINTER ARBOR FLAT SPRING

**Fig. 9 – Clock Movement and Dials — Model 6 Calculagraph Equipped With 24-Hour Time-of-Day Dial**



NOTES: 1 WHEN ORDERING THE CUP AND POINTER, ORDER A POINTER ARBOR COILED SPRING (SEE FIG 14) AND PINS AS REQUIRED WHEN THE CALCULAGRAPH IS EQUIPPED WITH A POINTER ARBOR FLAT SPRING  
 2 WHEN REPLACING EITHER CUP OR POINTER, REPLACE BOTH PARTS.

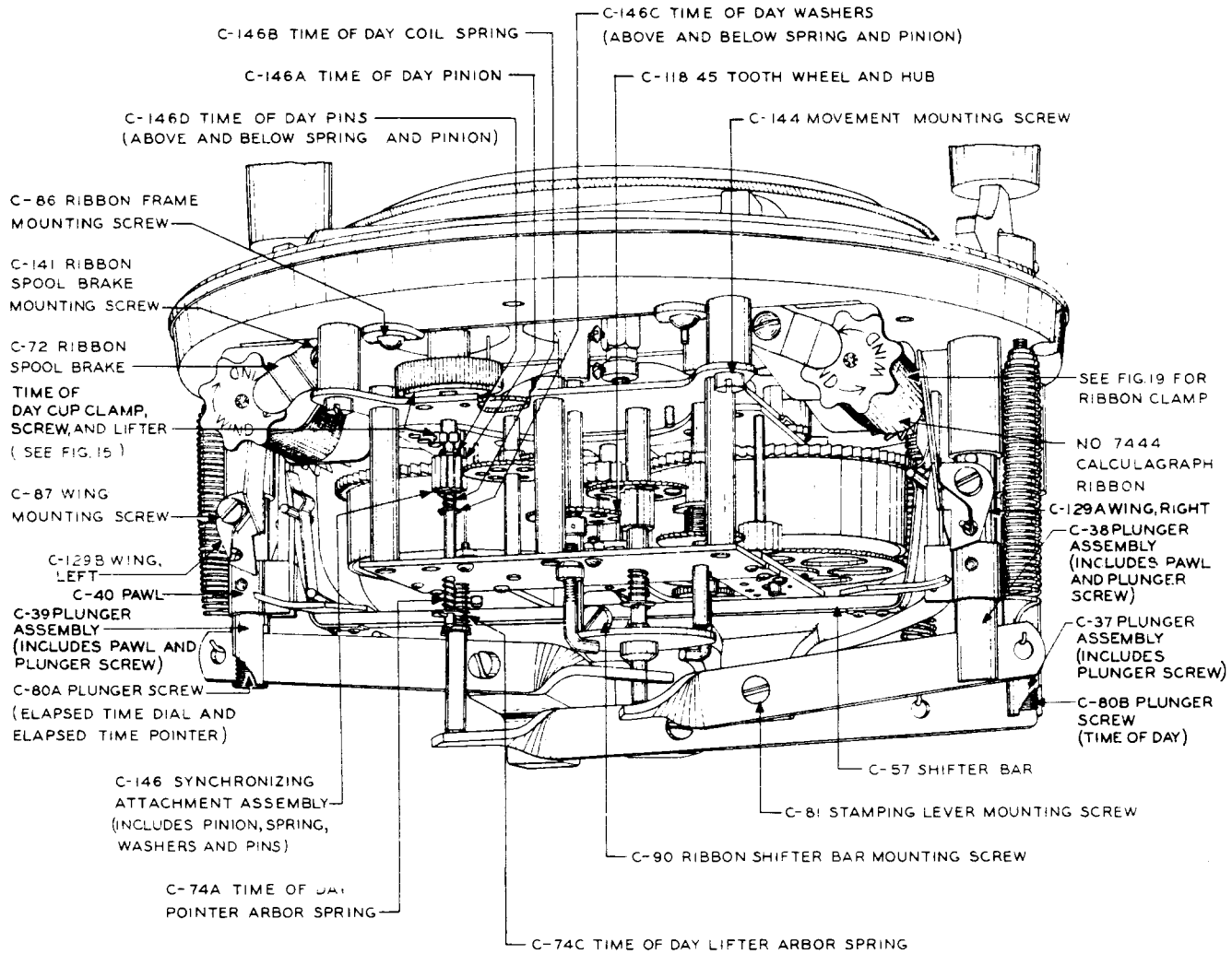
**Fig. 10 – Clock Movement and Dial — Model 30 Calculagraph Equipped With 24-Hour Time-of-Day Dial and 30-Minute Elapsed-Time Dial**



NOTES: 1 WHEN ORDERING THE CUP AND POINTER, ORDER A POINTER ARBOR COILED SPRING (SEE FIG 14) AND PINS AS REQUIRED WHEN THE CALCULAGRAPH IS EQUIPPED WITH A POINTER ARBOR FLAT SPRING

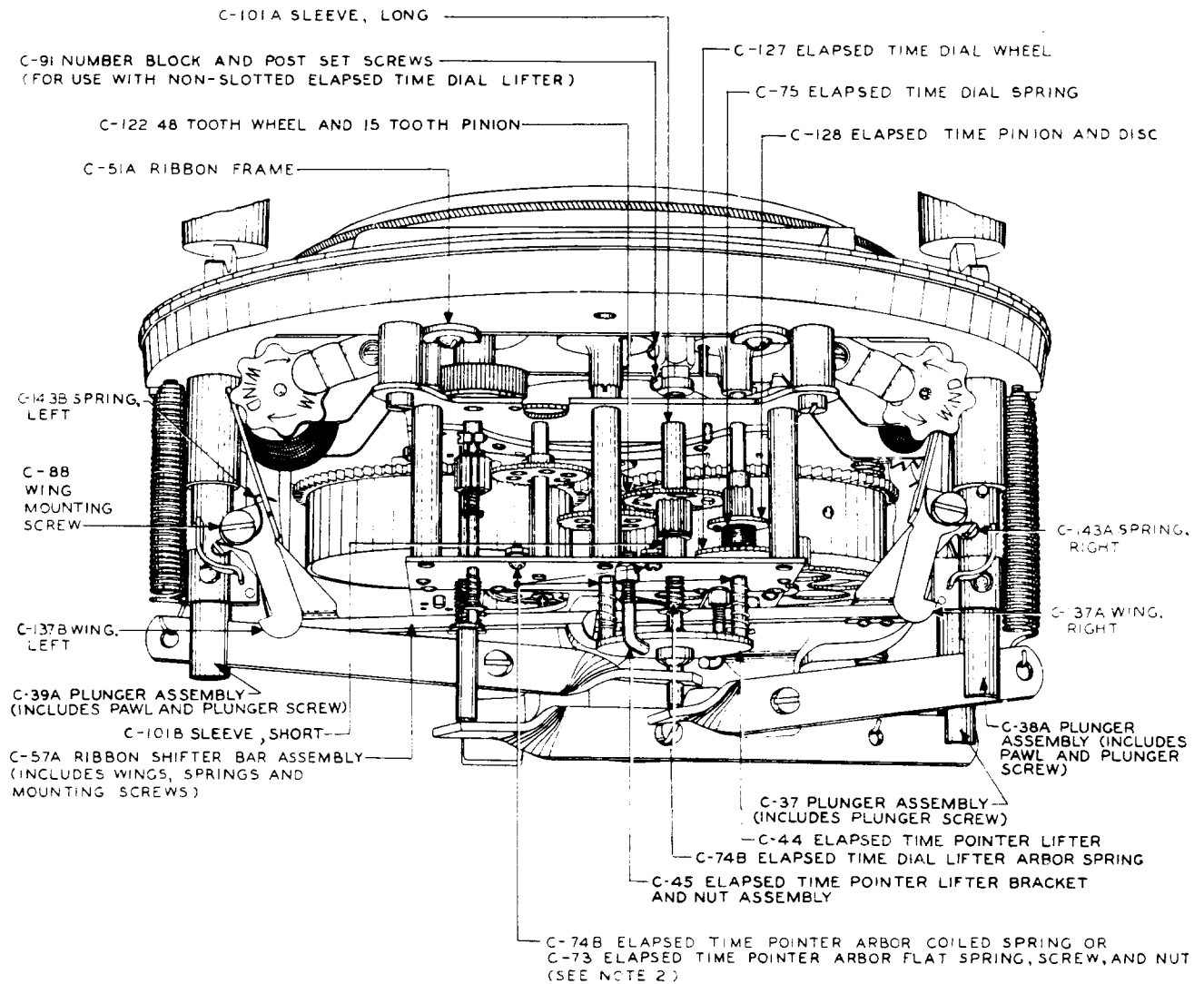
2 WHEN REPLACING EITHER CUP OR POINTER, REPLACE BOTH PARTS.

**Fig. 11 – Clock Movement and Dial — Model 30 Calculagraph Equipped With 24-Hour Time-of-Day Dial and 60-Minute Elapsed-Time Dial**



NOTE: THE PARTS SHOWN ON THIS FIGURE, WITH THE EXCEPTION OF THOSE ASSOCIATED WITH THE REVERSING MECHANISM, ARE COMMON TO MODEL 6 CALCULAGRAPHS EQUIPPED WITH EITHER THE FULL SPOOL OR UNWOUND SPOOL RIBBON REVERSE MECHANISM. REPLACEABLE PARTS NOT DESIGNATED ON THIS FIGURE ARE DESIGNATED ON FIG. 13

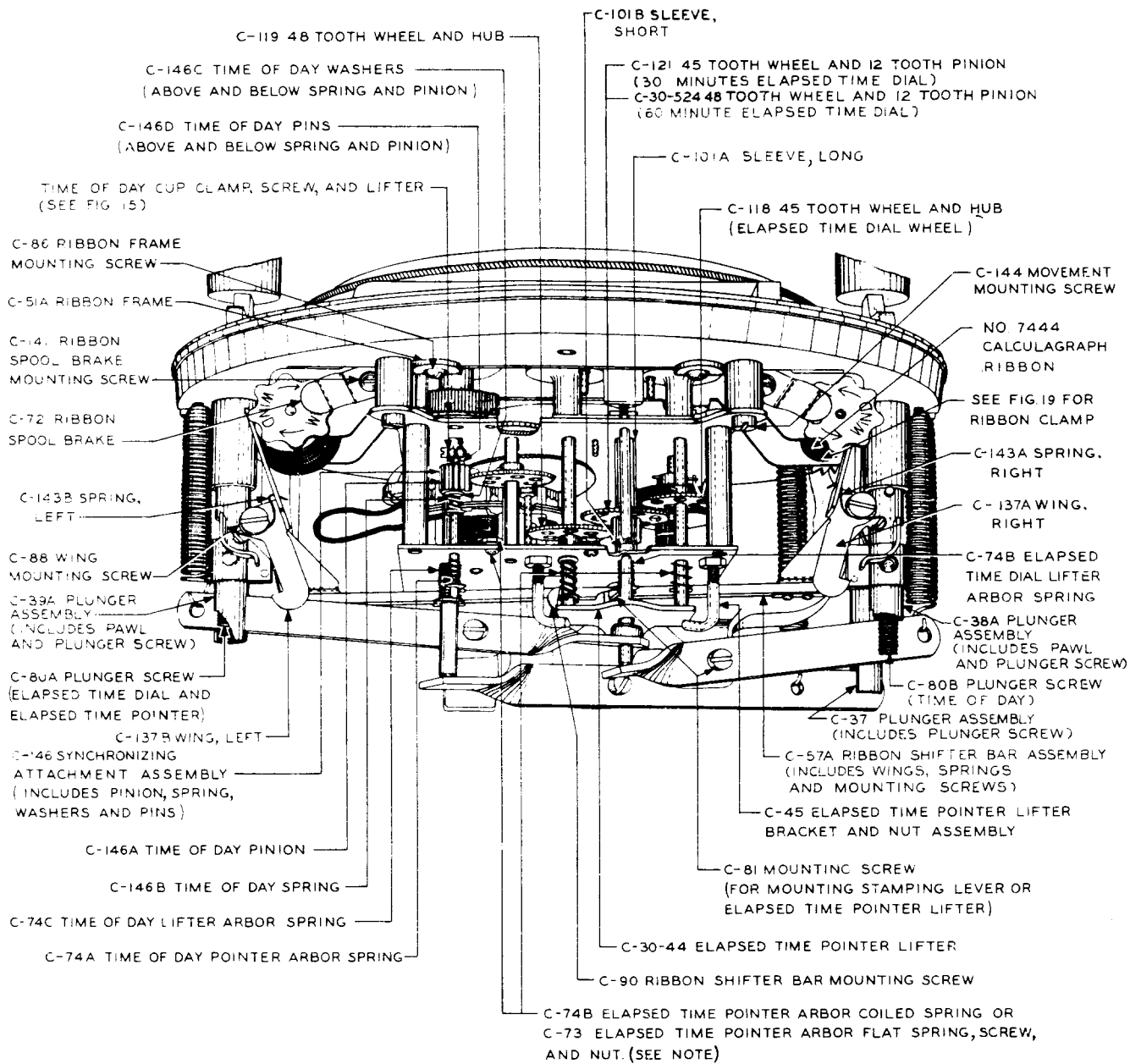
**Fig. 12 – Model 6 Calculagraph Equipped With Full Spool Ribbon Reverse Mechanism and 24-Hour Time-of-Day Dial**



NOTE 1 THE PARTS SHOWN ON THIS FIGURE, WITH THE EXCEPTION OF THOSE ASSOCIATED WITH THE REVERSING MECHANISM, ARE COMMON TO MODEL 6 CALCULAGRAPHS EQUIPPED WITH EITHER THE FULL SPOOL OR UNWOUND SPOOL RIBBON REVERSE MECHANISM REPLACEABLE PARTS NOT DESIGNATED ON THIS FIGURE ARE DESIGNATED ON FIG. 12

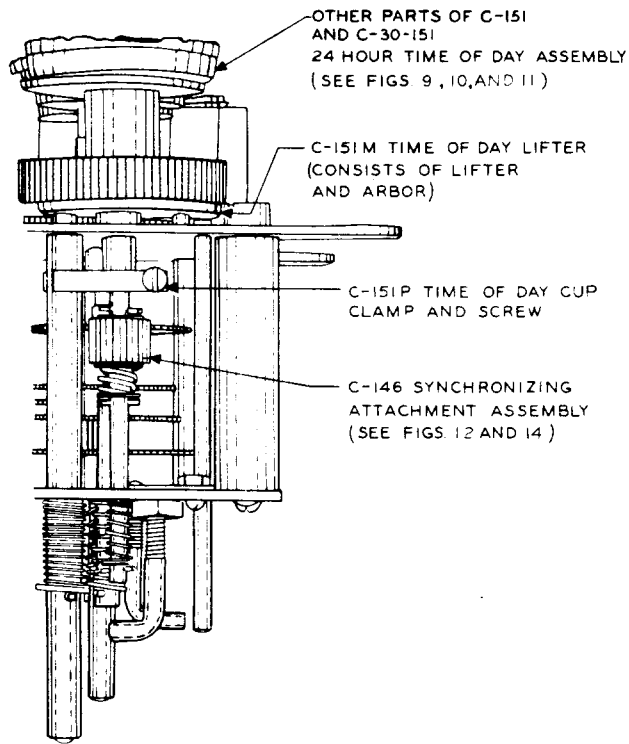
2 WHERE A CALCULAGRAPH IS EQUIPPED WITH A COILED SPRING ORDER A C-74B ELAPSED TIME POINTER ARBOR COILED SPRING WHERE A CALCULAGRAPH IS EQUIPPED WITH A FLAT SPRING ORDER A C-73 ELAPSED TIME POINTER ARBOR FLAT SPRING SEE FIG 8 FOR ORDERING THE SPRING WHEN ORDERING A POINTER ASSEMBLY FOR A CALCULAGRAPH EQUIPPED WITH A FLAT SPRING.

**Fig. 13 – Model 6 Calculagraph Equipped With Unwound Spool Ribbon Reverse Mechanism and 24-Hour Time-of-Day Dial**

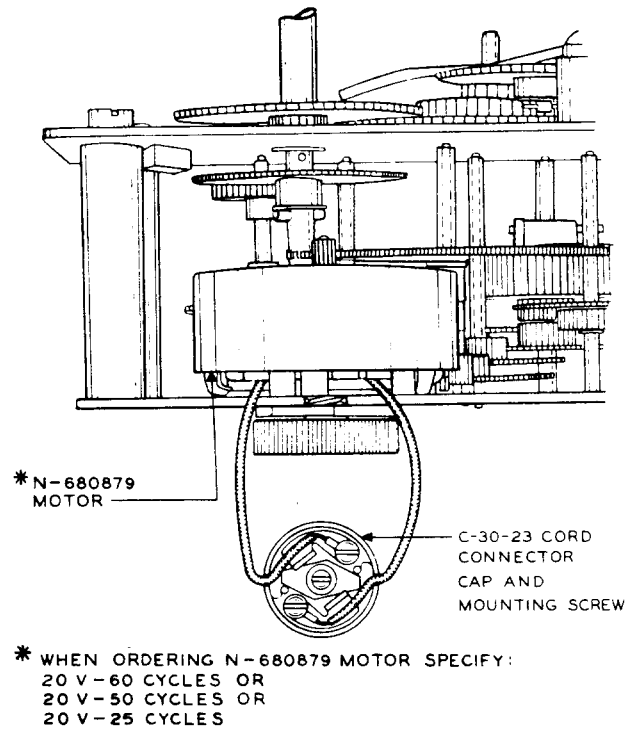


NOTE WHERE A CALCULAGRAPH IS EQUIPPED WITH A COILED SPRING ORDER A C-74B ELAPSED TIME POINTER ARBOR COILED SPRING. WHERE A CALCULAGRAPH IS EQUIPPED WITH A FLAT SPRING ORDER A C-73 ELAPSED TIME POINTER ARBOR FLAT SPRING. SEE FIG 10 FOR ORDERING THE SPRING WHEN ORDERING A POINTER ASSEMBLY FOR A CALCULAGRAPH EQUIPPED WITH A FLAT SPRING.

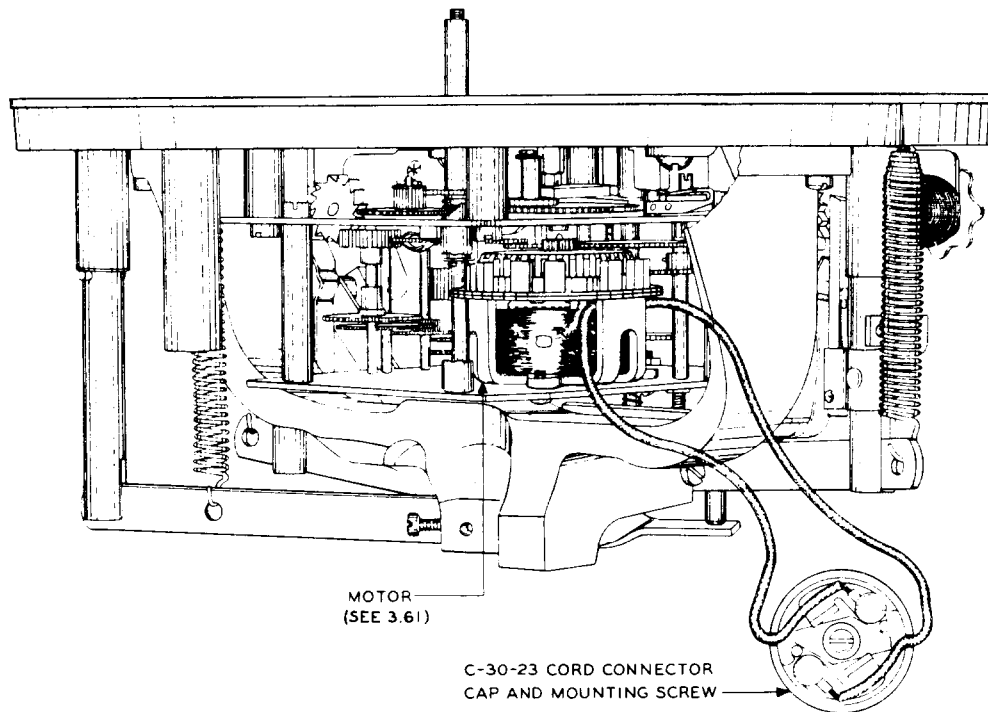
**Fig. 14 – Model 30 Calculagraph Equipped With Unwound Spool Ribbon Reverse Mechanism and 24-Hour Time-of-Day Dial (See Fig. 12 for Parts of Full Spool Ribbon Reverse Mechanism)**



**Fig. 15 - Clamping Arrangement for 24-Hour Time-of-Day Assembly**



**Fig. 16 - Motor Mechanism - Model 30 Calculagraph (Motor With Aluminum Cap Rotor)**



**Fig. 17 - Motor Mechanism - Model 30 Calculagraph (Motor With Copper Bar Rotor)**

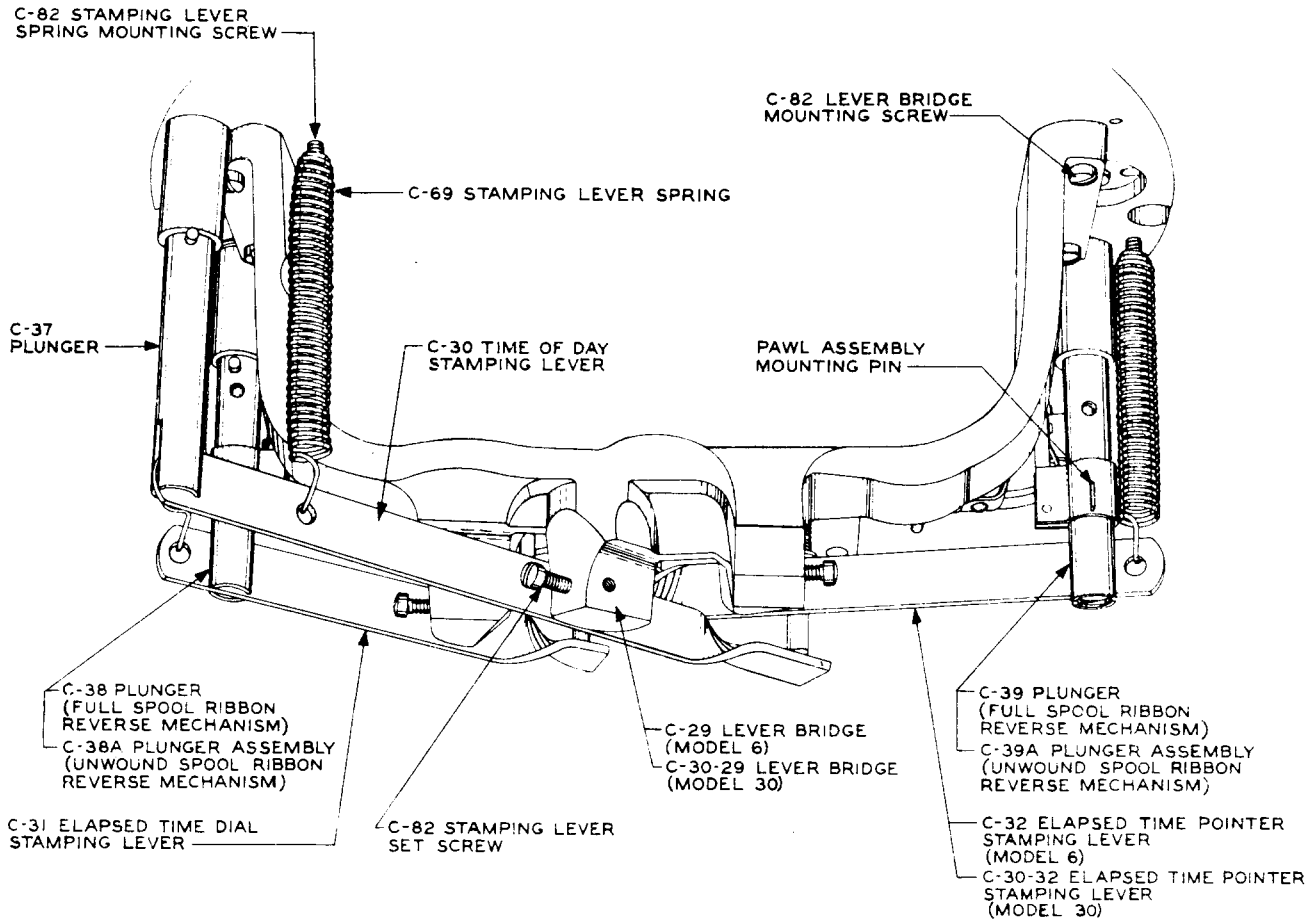


Fig. 18 – Stamping Mechanism — Models 6 and 30 Calculagraphs

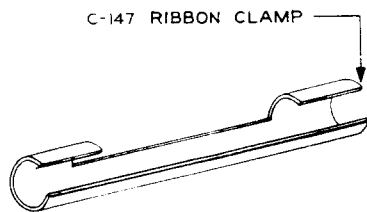


Fig. 19 – Ribbon Clamp



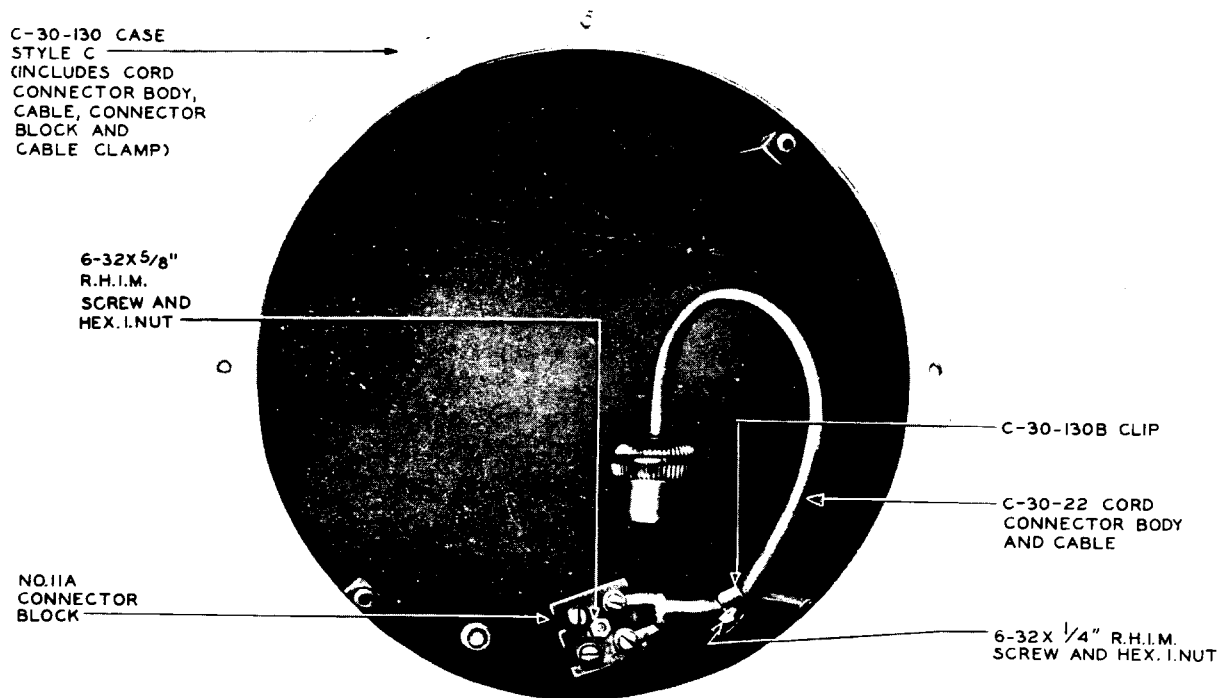


Fig. 20 — Case and Associated Parts — Model 30 Calculagraph

### 3. REPLACEMENT PROCEDURES

#### 3.01 List of Tools

CODE OR SPEC NO.	DESCRIPTION	CODE OR SPEC NO.	DESCRIPTION
		—	Long-Nose Pliers (or the replaced P-long-nose pliers)
417A	1/4- and 3/8-Inch Open Double-End Flat Wrench	—	3/32-Inch Drive Pin Punch, L.S. Starrett Co, No. 565 (or equivalent)
418A	5/16- and 7/32-Inch Open Double End Flat Wrench	—	5/32-Inch Drive Pin Punch, L.S. Starrett Co, No. 565 (or equivalent)
KS-6854	3-1/2 Inch Screwdriver	—	3-Inch C Screwdriver (or the replaced 3-inch cabinet screwdriver)
R-2512	8-Inch Adjustable Single-End Wrench	—	4-Inch E Screwdriver (or the replaced 4-inch regular screwdriver)
—	6-Inch Smooth-Cut Flat File	—	4-Inch B Screwdriver (or the replaced No. 2, 4-inch Phillips-type screwdriver)
—	4-Ounce Riveting Hammer		
—	5-Inch Diagonal Pliers		

## SECTION 030-100-801

**3.02** At the time of making the replacement of parts, clean and lubricate them in accordance with Section 030-100-701. After making any replacement of parts, check the Calculagraph and, where necessary, readjust it to meet the requirements specified in the section mentioned above.

**3.03** No replacement procedures are specified for screws or other small parts where the replacement consists of a simple operation.

**3.04** If in effecting the replacement of any part it has been necessary to stop the clock, check the hands of the clock with the time recorded by the time-of-day stamp for synchronization. To synchronize a clock that is not equipped with the synchronizing attachment, proceed as covered in Section 030-100-701. If it is equipped with the synchronizing attachment, proceed as follows. Calculagraphs equipped with a synchronizing attachment may be distinguished by the pinion on the time-of-day shaft being held in position by a spring under tension. Take an impression of the time-of-day dial. Hold the pinion with the fingers and grasp the end of the time-of-day shaft with the long-nose pliers and turn the shaft as required. Restore the Calculagraph to service and synchronize the Calculagraph with the other Calculagraphs in the operating room by turning the hands of the clock in a clockwise direction until the desired position is reached.

### HANDS

### SASH AND BEZEL, AND ASSOCIATED PARTS

### DIAL (FACE)

### PLATEN HOLDER AND PLATEN

### OPERATING LEVERS

### CAM POSTS

### AM AND PM STAMPS

### TICKET PLATE ASSEMBLY (TICKET PLATE AND CARD GATE)

**3.05 Hands:** In order to replace either the hour or minute hand, raise the bezel and loosen the knurled nut that secures the hands in place and remove the hands. Substitute the new part. If the hands are secured in place by a

washer and pin, remove them before removing the hands.

**3.06 Sash and Bezel, and Associated Parts:** If the glass in the bezel is cracked or broken, or the sash or bezel is defective, remove the sash mounting screws with the 3-inch C screwdriver and remove the sash and bezel. Replace these parts as a unit and secure the sash in place with the mounting screws. If the bezel stop is defective, remove the mounting screw with the 3-inch C screwdriver and replace the stop.

**3.07 Dial (Face):** If the dial (face) is defective, remove the hands and sash and bezel as covered above. Substitute the new part and then remount the sash and bezel and secure them in place with the mounting screws. Then mount and secure the hands in place on their respective shafts.

**3.08 Platen Holder and Platen:** If the platen holder is defective, remove the hands and sash and bezel as covered above and remove the platen holder mounting screws with the 4-inch E screwdriver. Remove the platen mounting screws with the 3-inch C screwdriver and remove the platen. Remount and secure the platen on the new holder with the platen mounting screws and then mount the holder on the main plate with the platen holder mounting screws. Securely fasten the sash and bezel on the platen holder and remount the hands on the minute and hour shafts, securing them in place as required. If the platen is defective, remove the hands as covered in 3.05. Remove the platen holder mounting screws with the 4-inch E screwdriver and remove the sash and bezel and platen holder as a unit. Then remove the platen mounting screws as covered above. Substitute the new part and securely tighten it in place with the mounting screws. Then remount the platen holder.

**3.09 Operating Levers:** Remove the platen holder as covered in 3.08. Drive the lever bearing pin from the mounting post with the 3/32-inch drive pin punch and 4-ounce riveting hammer and remove the lever. Substitute the new part and secure it in place with the bearing pin.

**3.10 Cam Posts:** To replace a cam post, remove the lever bridge as covered in 3.25. Remove the cam post nut, driving it in the direction so as to loosen it using the 5/32-inch drive pin punch and 4-ounce riveting hammer with the

punch applied to one of the notches in the nut. Remove the operating lever and cam post as a unit. Drive the lever bearing pin from the cam post with the 3/32-inch drive pin punch and 4-ounce riveting hammer. Substitute the new cam post and secure it in place with the bearing pin. Remount the operating lever and cam post as a unit and securely tighten the cam post nut using the punch and hammer. Remount and secure the lever bridge as covered in 3.25.

**3.11 *AM and PM Stamps:*** If either AM or PM stamp is defective, remove the platen holder as covered above. Unwind a portion of the ribbon and fold it back so that the AM and PM stamps are exposed. Then remove the defective stamp with the long-nose pliers. Substitute the new part on its associated post and press it into position. If there is not a perceptible clearance between the stamp and ribbon frame, remove the stamp from the shaft. Place the stamp in a vise and remove the excess material from the surface that is normally adjacent to the ribbon frame with the smooth-cut flat file. Take care in doing this that too much is not removed, that the amount that is removed is approximately the same for the entire surface, and that the surface is smooth after the operation is completed. Remove the stamp from the vise and mount it on the shaft. Repeat the operation until the desired clearance is obtained. Remount the platen holder and associated parts as covered above.

**3.12 *Ticket Plate Assembly (Ticket Plate and Card Gate):*** If the ticket plate assembly is to be replaced, remove the ticket plate mounting screws with the 3-inch C screwdriver and remove the ticket plate. Substitute the new part and tighten the mounting screws securely. If a card gate is to be replaced, remove the ticket plate assembly and remove the card gate by applying a slight pressure to the gate so as to remove the gate from the mounting grooves in the ticket plate. Note that the rounded corners of the card gate are slightly bent. Hold the ticket plate with the ticket stop on the underside. Slip the new gate into the grooves and under the springs of the ticket plate so that, *after* the ticket plate is positioned on the Calculagraph, the corner of the gate will be bent in the downward direction. Position the ticket plate and tighten the mounting screws.

## RIBBON

### RIBBON CLAMPS

**3.13** To replace an old or defective ribbon, remove the Calculagraph mounting screws with the 4-inch E screwdriver or the 4-inch B screwdriver, as required, and remove the Calculagraph from the container. Remove the ticket plate assembly from the Calculagraph as covered in 3.12. Remove the ribbon by withdrawing it upward so that it is unwound from both spools. Remove the ribbon clamps from the spools. If the clamps are old or defective, replace them at this time. Remove the new ribbon from the container and unroll about 12 inches. Replace the roll of ribbon in the container leaving the loose 12 inches of ribbon outside. Close or replace the cover making sure that the ribbon is not twisted. Place the loose end of the ribbon over one of the spools and secure it in place by placing the clamp over the ribbon and spool with the prongs of the clamp toward the loose end of the ribbon. If the spool has an annular slot, slide the clamp left or right so that the prongs of the clamp clear the slot. Wind all but 12 inches of the new ribbon on that spool. Then pass the free end of the ribbon over the roller and draw it over the time-of-day and elapsed-time dials. Slip the ribbon over the other roller and clamp it to the other ribbon spool as covered above. Take up whatever slack there may be in the ribbon by operating the operating lever.

**3.14** After the ribbon is satisfactorily mounted on the ribbon frame, remount and secure the ticket plate assembly as covered in 3.12. Then remount the Calculagraph in the container and insert and securely tighten the mounting screws.

### STAMPING LEVER SPRING

#### ELAPSED-TIME DIAL STAMPING LEVER

#### ELAPSED-TIME POINTER STAMPING LEVER

#### TIME-OF-DAY STAMPING LEVER

**3.15 *General:*** Before replacing any part covered by these procedures, remove the Calculagraph from the container as covered in 3.13. Then invert the Calculagraph, supporting it on the edge of the main plate and the operating

## SECTION 030-100-801

levers. Grasp the hooked end of the stamping lever springs associated with the parts to be replaced with the long-nose pliers and remove the spring from the stamping levers. After the replacement has been made and the parts are reassembled in place, insert the hooked end of each spring through the hole in the associated stamping lever with the long-nose pliers.

**3.16 Stamping Lever Spring:** To replace a stamping lever spring, insert the blade of the 3-inch C screwdriver down through the length of the spring and remove the stamping lever spring mounting screw. Then remove the screw from the spring and insert it in the new part. Remount and securely tighten the mounting screw in place.

**3.17 Elapsed-Time Dial, Elapsed-Time Pointer, and Time-of-Day Stamping Levers:** To replace a stamping lever, loosen the stamping lever setscrew and remove the stamping lever mounting screw with the 3-inch C screwdriver. Remove the lever from the slot in the plunger. Substitute the new part, insert and securely tighten the mounting screw and setscrew. If the elapsed-time pointer stamping lever is defective, remove the elapsed-time dial stamping lever before removing the faulty stamping lever. After substituting the new part, remount the elapsed-time dial stamping lever.

### PLUNGER SCREW (ALL PLUNGERS)

### FULL SPOOL RIBBON REVERSE MECHANISM

### PAWL

### WING

### PLUNGER ASSEMBLY

### UNWOUND SPOOL RIBBON REVERSE MECHANISM

### WING AND WING RETRACTILE SPRING

### PLUNGER ASSEMBLY

**3.18 General:** Before replacing a plunger screw, pawl, or plunger assembly, remove the associated stamping lever as covered in 3.17. Then, except when replacing a plunger screw, remove the plunger from the socket. Remount the parts in the reverse order of removal.

**3.19 Plunger Screw (All Plungers):** To replace the plunger screw, remove the screw from the plunger with the 3-inch C screwdriver.

Substitute the new part and adjust it as covered in Section 030-100-701. Remount the stamping lever.

### Full Spool Ribbon Reverse Mechanism

**3.20 Pawl:** If the pawl is defective, straighten the pin which mounts the pawl to the plunger with the long-nose pliers and drive it from the socket with the 4-ounce riveting hammer. Remove the pawl and substitute the new part in place, aligning the hole in the socket with the hole in the plunger. Insert the pin in the socket and drive it in place with the hammer. Then bend the pin to secure the assembly in place.

**3.21 Wing:** To replace the wing associated with either the elapsed-time dial or elapsed-time pointer, remove the wing mounting screw with the 4-inch E screwdriver and remove the wing. Substitute the new part and securely tighten the mounting screw. Take care in making this replacement that the pin on the plunger is inserted in the hole in the wing and that the retractile spring is in position to cause the wing to rest against the ribbon.

**3.22 Plunger Assembly:** If the plunger assembly is defective, replace it as a unit.

### Unwound Spool Ribbon Reverse Mechanism

**3.23 Wing and Wing Retractable Spring:** To replace the wing or wing retractile spring, remove the wing mounting screws with the 4-inch E screwdriver. Remove the loop of the retractile spring from the shifter bar with the long-nose pliers and remove the spring and wing from the bar. Take care not to distort the spring. Then remove the spring from the wing. Substitute the new part and remount the spring and wing on the shifter bar. Insert and securely tighten the mounting screw. Then place the loop of the spring over the post on the shifter bar.

**3.24 Plunger Assembly:** If a plunger assembly is defective, replace it as a unit.

### LEVER BRIDGE

### RIBBON SHIFTER BAR ASSEMBLY

**3.25** To replace a lever bridge or ribbon shifter bar assembly, remove the stamping levers and plungers as covered in 3.15, 3.17, and 3.18. Remove the lever bridge mounting screws using

the 3-inch C screwdriver. On the Model 30 Calculagraph, also free the elapsed-time pointer lifter. To free the lifter, loosen each of the lifter bracket locknuts using the long-nose pliers if the locknut is round or the No. 418A wrench if the locknut is hexagonal and turn the lifter brackets aside. Remove the lever bridge. In removing the bridge, take care that the ribbon shifter bar assembly which is mounted on the bridge is not damaged. Then remove the ribbon shifter bar mounting screw with the 3-inch C screwdriver and remove the bar. If the ribbon shifter bar of the full spool ribbon reverse mechanism is defective, replace the bar and the parts mounted on it as a unit. If the ribbon shifter bar of an unwound spool ribbon reverse mechanism is defective, remove the wing mounting screws with the 3-inch C screwdriver, remove the wing and associated parts as covered in 3.23, and securely mount these parts on the new shifter bar. Remount the ribbon shifter bar assembly on the lever bridge and secure it in place with the mounting screw. Then place the bridge in place on the main plate and securely tighten the lever bridge mounting screws. On the Model 30 Calculagraph, adjust the lifter brackets so that they support the lifter and tighten the locknuts securely. Remount the plungers and the stamping levers as covered in 3.15, 3.17, and 3.18.

#### **TIME-OF-DAY POINTER ARBOR SPRING**

#### **TIME-OF-DAY LIFTER ARBOR SPRING**

#### **TIME-OF-DAY DIAL, TIME-OF-DAY POINTER ASSEMBLY, TIME-OF-DAY PINION, AND SYNCHRONIZING ATTACHMENT (INCLUDES TIME-OF-DAY PINION)**

#### **STAR WHEEL**

#### **HOUR WHEEL SPOOL ASSEMBLY**

#### **TIME-OF-DAY LIFTER ASSEMBLY**

#### **DUPLEX WHEEL AND PINION**

**3.26 *Time-of-Day Pointer Arbor Spring:*** To replace a time-of-day pointer arbor spring, remove the time-of-day pointer arbor spring pin with the long-nose pliers and remove the washer. Substitute the new part, remount the washer on the shaft, and insert the pin in the hole in the shaft.

**3.27 *Time-of-Day Lifter Arbor Spring:*** To replace the time-of-day lifter arbor spring, remove the time-of-day lifter arbor spring pin with the long-nose pliers and remove the washer and spring. Substitute the new part, remount the washer, and insert the pin in the hole in the shaft.

#### **Time-of-Day Dial, Time-of-Day Pointer Assembly, Time-of-Day Pinion, Synchronizing Attachment, and Associated Parts**

**3.28 *General:*** To replace a time-of-day dial, time-of-day pointer, time-of-day pinion, or any part of the synchronizing attachment, remove the platen holder as covered in 3.08. Unroll about 12 inches of ribbon and lay it on the main plate. After replacing the parts, restore the ribbon and remount the platen holder.

#### ***Where Calculagraph Is Equipped With 12-Hour Time-of-Day Dial***

**3.29 *Where Calculagraph Is Not Equipped With Synchronizing Attachment:*** To replace the time-of-day dial, time-of-day pointer, and time-of-day pinion, remove the time-of-day pointer arbor spring as covered above. Then remove the time-of-day pinion pin and shaft pin with the long-nose pliers. Remove the time-of-day dial and time-of-day pointer assembly from the clock movement. Where the time-of-day dial does not fully seat in the time-of-day plate tube, the hub of the dial is too long. To correct, remove the dial from the Calculagraph. Place the smooth-cut flat file on a flat surface and file off the lower end of the hub as necessary. In removing the pointer assembly, the time-of-day pinion will drop off the shaft. Hold the pinion in position in mesh with the gear and with the hub of the pinion at the bottom, then substitute the shaft of the new time-of-day pointer assembly through the hour wheel spool, upper plate of the clock movement, pinion, and then through the lower plate of the clock movement. Locate the shaft so that the lower hole in the shaft is in alignment with the hole in the hub of the pinion. Then insert the pin through the hub and shaft, securing them together. Remount the shaft pin, arbor spring, washer, and arbor spring pin as covered above.

**3.30 Where Calculagraph Is Equipped With Synchronizing Attachment:** Remove all pins from the time-of-day pointer shaft with the long-nose pliers and remove the time-of-day pointer arbor spring. Raise the time-of-day pointer enough beyond the lower plate of the clock movement to permit the removal of the washers, pinion, and spring. If the pointer or dial is to be replaced, remove them at this time. Substitute the new part and reassemble the parts in the following order. Place one washer over the end of the pointer shaft, then the compression spring, another washer, the pinion, and another washer. Place the shaft in the lower plate bearing and place the arbor spring and washer over the end of the shaft. Insert the pin through the hole near the end of the shaft. Insert the pin in the uppermost hole in the shaft. Mesh the teeth of the pinion with its associated gear. Compress the compression spring by placing the thumb of one hand under the washer that is beneath the pinion and raise the entire assembly until the pin can be inserted in the hole in the shaft beneath the washer. If a pin is too long, cut it off to a satisfactory length with the diagonal pliers.

**3.31 Star Wheel:** To replace the star wheel, remove the star wheel shoulder screw with the KS-6854 screwdriver and remove the AM and PM stamps as covered in 3.11. Then remove the star wheel. Substitute the new part and remount and securely tighten the shoulder screw. Then remount the AM and PM stamps on their respective posts.

**3.32 Hour Wheel Spool Assembly:** To replace the hour wheel spool assembly, remove the time-of-day dial and star wheel as covered above. Remove the hour wheel spool assembly and substitute the new part. Then reassemble as covered above.

**3.33 Time-of-Day Lifter Assembly:** To replace the time-of-day lifter assembly, remove the time-of-day dial, star wheel, and hour wheel spool assembly as covered above. Remove the time-of-day lifter arbor spring as covered in 3.27 and remove the lifter from the clock movement. Substitute the new part and remount the arbor spring, washer, and pin. Then reassemble the hour wheel spool assembly, star wheel, and time-of-day dial as covered above.

**3.34 Duplex Wheel and Pinion:** To replace the duplex wheel and pinion, remove the hour wheel spool assembly as covered in 3.32. Then remove the duplex wheel pin from the shaft with the long-nose pliers and remove the duplex wheel and pinion. Substitute the new part and insert the pin. Then reassemble the hour wheel spool assembly as covered in 3.32.

***Where Calculagraph Is Equipped with 24-Hour Time-of-Day Dial***

**3.35 Time-of-Day Pinion and Time-of-Day Pointer (Where Calculagraph Is Not Equipped With Synchronizing Attachment):** Remove the time-of-day shaft spring as covered in 3.26 and remove the pin from the hub of the time-of-day pinion with the long-nose pliers. To replace the time-of-day pinion, raise the pointer enough beyond the lower plate of the clock movement to permit the pinion to be removed. Substitute the new part, mount the pinion on the shaft, and mesh it with its associated gear. Secure the pinion in place on the shaft with the pin. To replace the time-of-day pointer, proceed as covered above and remove the pointer shaft through the upper plate of the clock movement. Substitute the new part and insert it down through the upper plate. Mount the time-of-day pinion on the shaft and proceed as covered above.

**3.36 Synchronizing Attachment and Time-of-Day Pointer (Where Calculagraph Is Equipped With Synchronizing Attachment):** Remove the time-of-day shaft spring as covered in 3.26 and then remove all other pins from the time-of-day pointer shaft with the long-nose pliers. If any part of the synchronizing attachment is to be replaced, raise the time-of-day pointer enough beyond the lower plate of the clock movement to permit the removal of the washers, compression spring, or time-of-day pinion, as required. Make the necessary replacement of parts and reassemble the parts in the reverse order from which they were removed. If the entire assembly was removed, proceed as follows. Place one washer over the end of the pointer shaft, then the pinion, another washer, the compression spring, and another washer. Insert the shaft through the lower plate and place the shaft spring and washer over the end of the shaft. Insert a pin through the hole near the end

of the shaft. Insert a pin through the uppermost hole in the shaft. Mesh the teeth of the pinion with its associated gear. Compress the compression spring by placing the thumb of one hand under the washer that is beneath the spring and raise the entire assembly until the pin can be inserted in the hole in the shaft beneath the washer. If the pin is too long, cut it off to a satisfactory length with the diagonal pliers. To replace the time-of-day pointer, remove the parts mounted on the shaft as covered above and remove the pointer shaft through the upper plate of the clock movement. Substitute the new part and insert the shaft down through the upper plate and reassemble the parts on the shaft as covered above.

**3.37 *Time-of-Day Dial, Clamping Collar, and Time-of-Day Spool and Triangle:*** To replace the time-of-day dial, clamping collar, or time-of-day spool and triangle, remove the time-of-day pointer as covered in 3.35 or 3.36 depending on whether or not the Calculagraph is equipped with a synchronizing attachment. Loosen the clamping collar screw with the KS-6854 screwdriver and remove the clamping collar from the time-of-day dial shaft. Remove the dial and spool, as required. Make the necessary replacement of parts and reassemble them in place on the upper plate. Mount the clamping collar on the time-of-day shaft and secure it in place as covered in Section 030-100-701. Reassemble the time-of-day pointer and associated parts as covered in 3.35 and 3.36.

**3.38 *Time-of-Day Lifter:*** To replace the time-of-day lifter, remove the time-of-day dial and spool and triangle as covered in 3.37. Remove the pin from the time-of-day lifter shaft with the long-nose pliers and remove the washer and spring. Remove the lifter from the clock movement. Substitute the new part and mount it through the clock movement. Mount the shaft spring and washer in place and insert the pin through the shaft. Reassemble the other parts that were removed as covered in 3.37.

**3.39 *Duplex Wheel and Hub:*** To replace the duplex wheel and hub, remove the time-of-day lifter as covered in 3.38. Remove the pin from the hub of the duplex wheel with the long-nose pliers and remove the duplex wheel.

Substitute the new part on the shaft and insert the pin through the hub and shaft. Remount the parts that were removed as covered in 3.38.

**ELAPSED-TIME POINTER LIFTER AND ELAPSED-TIME POINTER LIFTER BRACKET**

**ELAPSED-TIME POINTER ARBOR SPRING (HELICAL SPRING) AND ELAPSED-TIME DIAL LIFTER ARBOR SPRING**

**ELAPSED-TIME POINTER ARBOR SPRING (FLAT SPRING)**

**(MODEL 6) ELAPSED-TIME DIAL ASSEMBLY (60 MINUTE), POINTER ASSEMBLY, AND WHEEL**

**(MODEL 6) ELAPSED-TIME DIAL ASSEMBLY (5 MINUTE), POINTER ASSEMBLY, PINION ASSEMBLY, WHEEL, AND SPRING**

**(MODEL 30) ELAPSED-TIME CUP AND POINTER (60 SECOND, 30 OR 60 MINUTE) AND WHEEL**

**ELAPSED-TIME DIAL LIFTER, WHEEL AND PINION, SLEEVES, WASHERS, AND NUMBER BLOCK, TYPE, AND POST ASSEMBLY**

**NUMBER BLOCK (ASSOCIATED WITH ELAPSED-TIME POINTER LIFTER — MODEL 30)**

**3.40 *General:*** To raise any of the parts through the upper plate of the clock movement, as covered in 3.44 to 3.51, inclusive, remove the platen holder as covered in 3.08 and pull the ribbon loose to free the stamping dials and associated parts. After making the necessary replacement of parts, restore the ribbon and remount the platen holder.

**3.41 *Elapsed-Time Pointer Lifter and Elapsed-Time Pointer Lifter Bracket:*** To replace the elapsed-time pointer lifter bracket, remove the bracket with the long-nose pliers if the locknut is round or with the No. 418A wrench if the nut is hexagonal. Remove the locknut and place it on the new part. Mount the new part in place on the frame and turn it into position with the long-nose pliers or wrench as required. Turn the locknut in until it holds the bracket in place. If on the Model 6 Calculagraph the elapsed-time pointer lifter does not lie flat on the brackets, remove the bracket at fault and file the upper surface of the bracket as required with the smooth-cut flat file. Then remount the bracket as covered above. If the elapsed-time pointer

lifter is defective, loosen the locknuts on both lifter brackets and turn the brackets aside. Remove the elapsed-time pointer and dial stamping levers as covered in 3.15 and 3.17 and then, on a Model 6 Calculagraph, remove the pointer lifter from the shaft. On a Model 30 Calculagraph, proceed further by removing the lever bridge and the ribbon shifter bar assembly as covered in 3.25. Then remove the pointer lifter mounting screw using the 3-inch C screwdriver and remove the pointer lifter. Substitute the new part, remount the parts, reposition the pointer lifter brackets, and tighten the bracket locknuts.

**3.42 *Elapsed-Time Pointer Arbor Spring (Helical Spring) and Elapsed-Time Dial Lifter Arbor Spring:*** Remove the elapsed-time pointer lifter as covered above. Then remove the arbor spring pin with the long-nose pliers. Remove the washer and then the spring. Substitute the new part, remount the washer, and insert the pin in the hole of the arbor. Then remount the pointer lifter and brackets as covered above.

**3.43 *Elapsed-Time Pointer Arbor Spring (Flat Spring):*** To replace a flat-type elapsed-time pointer arbor spring, loosen the arbor spring mounting screw with the 3-inch C screwdriver and remove the screw, mounting nut, and spring. Substitute the new part, insert the mounting screw, and secure it in place with the mounting nut. To do this, hold the mounting nut in place with the long-nose pliers and tighten the screw with the 3-inch C screwdriver.

**3.44 *(Model 6 Calculagraph Equipped With a Pointer Arbor Flat Spring) Elapsed-time Dial Assembly (60 Minute), Pointer Assembly, and Wheel:*** To replace any of these parts, remove the arbor spring as covered in 3.43. Remove the elapsed-time dial wheel pin with the long-nose pliers. To replace the wheel, hold it with the fingers of one hand and raise the pointer shaft up through the upper plate of the clock movement far enough to remove the wheel. Insert a new wheel on the shaft and mesh it with its associated gear. Lower the shaft in place holding the wheel in position. Align the hole in the shaft with the hole in the hub of the wheel. Insert the pin through the holes. Remount the arbor spring. If either the elapsed-time dial assembly or pointer assembly is to be replaced, remove the

shaft through the upper plate of the clock movement. Substitute the new dial or pointer assembly as required. Insert the pointer shaft down through the plates placing the wheel on the shaft in mesh with its associated gear. If the pointer assembly is replaced, do not remount the pointer arbor flat spring, but substitute a helical-type spring. Mount the helical spring over the end of the pointer shaft. Insert a pin in the hole at the end of the shaft to hold the helical spring in place. Then pin the wheel to the shaft. If the pointer assembly is not replaced, proceed as covered above, but remount the pointer arbor flat spring instead of mounting the helical spring.

**3.45 *(Model 6 Calculagraph Equipped With a Pointer Arbor Helical Spring) Elapsed-Time Dial Assembly (60 Minute), Pointer Assembly, and Wheel:*** Remove the pins holding the wheel and helical spring on the pointer shaft using the long-nose pliers. Then to replace any of these parts, proceed as covered in 3.44 as applicable to the pointer arbor helical spring. If a washer associated with the helical spring is removed, remount the washer.

**3.46 *(Model 6 Calculagraph Equipped With a Pointer Arbor Flat Spring) Elapsed-Time Dial Assembly (5 Minute), Pointer Assembly, Pinion Assembly, Wheel, and Spring:*** To replace any of these parts, remove the arbor spring as covered in 3.43. Remove the pins that secure the pinion and wheel in place with the long-nose pliers. To replace a wheel, spring, or pinion, hold the parts with the fingers of one hand and raise the pointer shaft up through the upper plate of the clock movement far enough to remove the part. Remove the part to be replaced and substitute the new part. Engage the spring over the posts on the pinion and wheel and mesh the parts with their associated wheels or gears. Lower the shaft in place holding the pinion and wheel in position. Align the holes in the parts with the holes in the shaft. Insert the pins through the holes. Remount the arbor spring. If either the dial assembly or pointer assembly is to be replaced, remove the shaft through the upper plate of the clock movement. Substitute the new dial or pointer assembly as required. Insert the pointer shaft down through the plates, placing the pinion and wheel on the shaft with the pinion in mesh with its associated gear. Engage the



spring over the posts on the pinion and wheel. If the pointer assembly is replaced, do not remount the pointer arbor flat spring, but substitute a helical-type spring. Mount the helical spring over the end of the pointer shaft. Insert a pin in the hole at the end of the shaft to hold the helical spring in place. Then pin both the pinion and wheel to the shaft. If the pointer assembly is not replaced, proceed as above, but remount the pointer arbor flat spring instead of mounting the helical spring.

**3.47** (*Model 6 Calculagraph Equipped With a Pointer Arbor Helical Spring*) *Elapsed-Time Dial Assembly (5 Minute), Pointer Assembly, Pinion Assembly, Wheel, and Spring*: Remove the pins holding the pinion assembly, wheel, and helical spring on the pointer shaft using the long-nose pliers. Then, to replace any of these parts, proceed as covered in 3.46 as applicable to the pointer arbor helical spring. If a washer associated with the helical spring is removed, remount the washer.

**3.48** (*Model 30 Calculagraph Equipped With a Pointer Arbor Flat Spring*) *Elapsed-Time Cup and Pointer (60 Second, 30 or 60 Minute) and Wheel*: To replace any of these parts, remove the arbor spring as covered in 3.43. Remove the pin that secures the wheel in place with the long-nose pliers. If the wheel is to be replaced, hold the wheel and raise the pointer shaft up through the upper plate of the clock movement far enough to remove the wheel. Mount a new wheel on the shaft and lower the shaft in place. Mesh the wheel with its associated gear. Align the hole in the hub of the wheel with the hole in the shaft and secure it in place with a pin. Remount the arbor spring. If either the cup (dial) or pointer (pointer shaft) is to be replaced, replace the parts as a fitted unit consisting of a mated cup and pointer. To replace the cup and pointer, raise the pointer shaft and remove the wheel. Raise the shaft through the upper plate of the clock movement. Substitute the new mated dial and pointer. Insert the pointer shaft down through the plates placing the wheel on the shaft in mesh with its associated gear. If the cup and pointer are replaced, do not remount the pointer arbor flat spring, but substitute a helical-type spring. Mount the helical spring over the end of the pointer shaft. Insert a pin in the

hole at the end of the shaft to hold the helical spring in place. Then pin the wheel to the shaft. If the cup and pointer are not replaced, proceed as above, but remount the pointer arbor flat spring instead of mounting the helical spring.

**3.49** (*Model 30 Calculagraph Equipped With a Pointer Arbor Helical Spring*) *Elapsed-Time Cup and Pointer (60 Second, 30 or 60 Minute) and Wheel*: Remove the pins holding the wheel and helical spring on the pointer shaft, using the long-nose pliers. Then, to replace any of these parts, proceed as covered in 3.48 as applicable to the pointer arbor helical spring. If a washer associated with the helical spring is removed, remount the washer.

**3.50** *Elapsed-Time Dial Lifter, Wheel and Pinion, Sleeves, Washers, and Number Block, Type, and Post Assembly*: To replace the number block, type, and post assembly, loosen the post setscrew, if furnished, with the 3-inch C screwdriver. On a Model 30 Calculagraph, remove the front number assembly by lifting the assembly up through the upper plate. Remove the post assembly with the No. 417A wrench. Mount the new post assembly, tighten the setscrew, where furnished, and remount the front number assembly where removed. To replace any other parts, remove the elapsed-time dials as covered above. Remove the elapsed-time dial lifter arbor spring pin with the long-nose pliers and remove the elapsed-time dial lifter washer and arbor spring. Raise the lifter through the upper plate of the clock movement enough to clear the part to be replaced and make the necessary replacement of parts. Take care in removing it that the sleeves, washers, and wheel and pinion are not damaged. When the lifter is to be replaced, raise the entire shaft through the upper plate and remove the post assembly as covered above. Mount the post assembly on the new lifter and place the long sleeve in position on the underside of the upper plate. Then insert the shaft of the new elapsed-time dial lifter through the hole in the upper plate and through the long sleeve. With the shaft extending slightly beyond the lower end of the long sleeve, place a washer over the end of the shaft. Then place the wheel in position with the pinion at the bottom. Lower the shaft through the wheel and pinion. Then place the washers on the shaft below the

pinion and the short sleeve in position between the washers and the upper surface of the lower plate. Lower the shaft through the sleeve and lower plate. Remount the elapsed-time dial lifter arbor spring and the washer.

**3.51 Number Block (Associated With Elapsed-Time Pointer Lifter — Model 30 Calculagraphs):** Lift the block shaft through the upper plate of the clock movement. If either the number block or shaft is defective, disengage the parts by grasping the shaft with the long-nose pliers and turning the block out. Make the necessary substitution of parts and reassemble the block and shaft. Insert the shaft down through the upper and lower plates of the clock movement.

**HOURLY WHEEL AND TUBE ASSEMBLY, MINUTE WHEEL AND PINION, 100-TOOTH WHEEL, AND GEAR BRIDGE AND 60-TOOTH WHEEL**

**3.52 General:** To replace these parts, remove the Calculagraph from the container and remove the dial as covered in 3.07. To remove the 100-tooth wheel, remove the lever bridge as covered in 3.25 and remove the clock movement mounting screws with the 4-inch E screwdriver. Remove the clock movement from the main plate. After making the necessary replacement of parts, remount the clock movement, insert and securely tighten the mounting screws, and remount the lever bridge as covered in 3.25.

**Where Calculagraph Is Equipped With 12-Hour Time-of-Day Dial**

**3.53 Hour Wheel and Tube Assembly:** To replace the hour wheel and tube assembly, remove the pin from the shaft of the minute wheel and pinion with the long-nose pliers, exercising care not to bend the shaft, and remove the washer. Then remove the hour wheel and tube assembly from the main shaft. Substitute the new part on the shaft, meshing it with the minute wheel and pinion. Then remount the minute wheel and pinion washer and insert the pin in place.

**3.54 Minute Wheel and Pinion:** To replace the minute wheel and pinion, remove the hour wheel and tube assembly, as covered above, and then remove the wheel. Substitute the new part

and mesh it with the gear on the main shaft. Then remount the hour wheel and tube assembly, as covered above, and remount the washer and insert the pin in place.

**3.55 100-Tooth Wheel:** To replace the 100-tooth wheel, proceed as follows. On Model 6 Calculagraphs, remove the hour wheel and the tube assembly as covered in 3.53, remove the pin from the shaft of the 100-tooth wheel with the long-nose pliers exercising care not to bend the shaft, and remove the washer. Remove the wheel. Substitute the new part and mesh the teeth of the wheel with the teeth of the gear on the main shaft and teeth of the duplex wheel. Then remount the washer and pin of the 100-tooth wheel and reassemble the hour wheel and tube assembly as covered in 3.53. Reassemble the other parts that were removed as covered in their associated procedures. On Model 30 Calculagraphs, remove the elapsed-time dial lifter as covered in 3.50 and proceed as covered above. After making the necessary replacement of parts, reassemble as covered above and in 3.50.

**Where Calculagraph Is Equipped With 24-Hour Time-of-Day Dial**

**3.56 Gear Bridge and 60-Tooth Wheel:** To replace either the gear bridge or 60-tooth wheel, remove the gear bridge mounting screws with the 3-inch C screwdriver and remove the bridge. Remove the pin from the bridge post with the long-nose pliers and remove the wheel. Substitute the new part and mount the wheel on the post. Insert the pin through the post. Mount the bridge on the posts and insert and securely tighten the mounting screws.

**3.57 Hour Wheel and Tube:** To replace the hour wheel and tube, remove the gear bridge as covered in 3.56. Remove the hour wheel and tube and substitute the new part meshing the teeth with its associated wheel. Remount the gear bridge securely in place.

**3.58 100-Tooth Wheel and Associated Parts:** To replace the 100-tooth wheel or any of the associated parts mounted on the same post, remove the gear bridge and hour wheel and proceed as follows. On Model 6 Calculagraphs, remove the assembled gears from the mounting

post and substitute the new parts, meshing the teeth with the associated parts. Remount the parts that were removed as covered in 3.56 and 3.57. On Model 30 Calculagraphs, it will be necessary to remove the elapsed-time dial lifter as covered in 3.50 and to remove the assembled gears from the mounting post. Substitute the new parts and mesh the teeth with the associated parts. Remount the parts that were removed as covered in 3.50, 3.56, and 3.57.

#### **RIBBON SPOOL BRAKE**

#### **RIBBON FRAME**

**3.59** To replace the ribbon spool brake, remove the Calculagraph from the container as covered in 3.13. Remove the ribbon spool brake mounting screw with the 3-inch C screwdriver. Remove the brake. Substitute the new part and insert and securely tighten the mounting screw.

**3.60** To replace the ribbon frame, remove the hands, bezel, platen holder, and ticket plate as covered in 3.05, 3.06, 3.08, and 3.12 and remove the lever bridge and clock movement as covered in 3.25 and 3.52. Remove the ribbon frame mounting screws with the 3-inch C screwdriver and remove the frame. Substitute the new frame and securely tighten the mounting screws. If the frame does not project slightly above the upper surface of the main plate, adjust the position of the frame as covered in Section 030-100-701. Reassemble the Calculagraph as covered in 3.52.

**3.61** *Motor (Model 30 Calculagraph):* When a Calculagraph is equipped with a motor having a copper bar rotor, return the motor to the Calculagraph Company for the replacement. However, when the motor has an aluminum cap

rotor, proceed as follows. Remove the lever bridge as covered in 3.25. Remove the knurled cap of the motor. Remove the bearing assembly using the R-2512 wrench. Remove the motor from the lower plate. Mount the new motor in the reverse order, engaging the pinion of the motor with its associated gear as covered in Section 030-100-701. Remount and secure the lever bridge as covered in 3.25.

#### **PACKING CALCULAGRAPHS**

**3.62** If it is necessary to ship a Calculagraph out of the office in order to make repairs or adjustments not covered in this section or Section 030-100-701, proceed as follows.

**3.63** On a Model 6 Calculagraph, remove the Calculagraph mounting screws with the 4-inch E screwdriver and remove the Calculagraph from its container. Stop the clock movement by looping a string through the balance wheel and tying the string to an adjacent stud or post on the clock movement frame. Remount the Calculagraph in the container and insert and tighten the mounting screws securely.

**3.64** Insert a ticket in the ticket slot and then wrap the Calculagraph in paper.

**3.65** Pack and completely block the Calculagraph in a Calculagraph packing box. If required, use excelsior, felt, or paper as additional packing around the Calculagraph to block the Calculagraph securely. If a wooden box is used, secure the box cover in place with screws.

**3.66** Then stencil or paint the number of the Calculagraph and the necessary shipping directions on the box.