

**CALCULAGRAPHS**  
**KS-7769 (MODEL 33)**  
**PIECE-PART DATA AND REPLACEMENT PROCEDURES**

**1. GENERAL**

**1.01** This section covers the information necessary for ordering parts to be used in the maintenance of KS-7769 Calculagraphs. It also covers approved procedures for replacing these parts.

**1.02** This section is reissued to revise the piece-part data for the ticket plate and to revise Fig. 1.

**1.03** Part 2 of this section covers the piece-part numbers and the corresponding names of the parts which it is practicable to replace in the field in the maintenance of the above apparatus. No attempt should be made to replace parts not designated. Part 2 also contains explanatory figures showing the different parts. This information is called Piece-Part Data.

**1.04** Part 3 of this section covers the approved procedures for the replacement of the parts listed under Part 2. This information is called Replacement Procedures.

**2. PIECE-PART DATA**

**2.01** The figures included in this part show the various piece parts in their proper relation to other parts of the apparatus. The piece-part numbers of the various parts are given together with the names of the parts assigned by the manufacturer.

**2.02** When ordering piece parts for replacement purposes, give both the number and the name of the part. For example, 33-160 time-of-day cup. Except where a specific number is given, when ordering pins to secure the various wheels, shafts, or pinions, order C-138 Pins, Tapered, Assorted, for KS-7769 Calculagraph. Except where a specific number is given when ordering washers, order Washers, Assorted, for KS-7769 Calculagraph. Do not refer to the section number or to any information shown in parentheses following the piece-part numbers.

**2.03** Information enclosed by parentheses ( ) is not ordering information. This information may be references to notes, parts referred to in other portions of the section and not considered replaceable, or part names in general use in the field if these names differ from those assigned by the manufacturer.

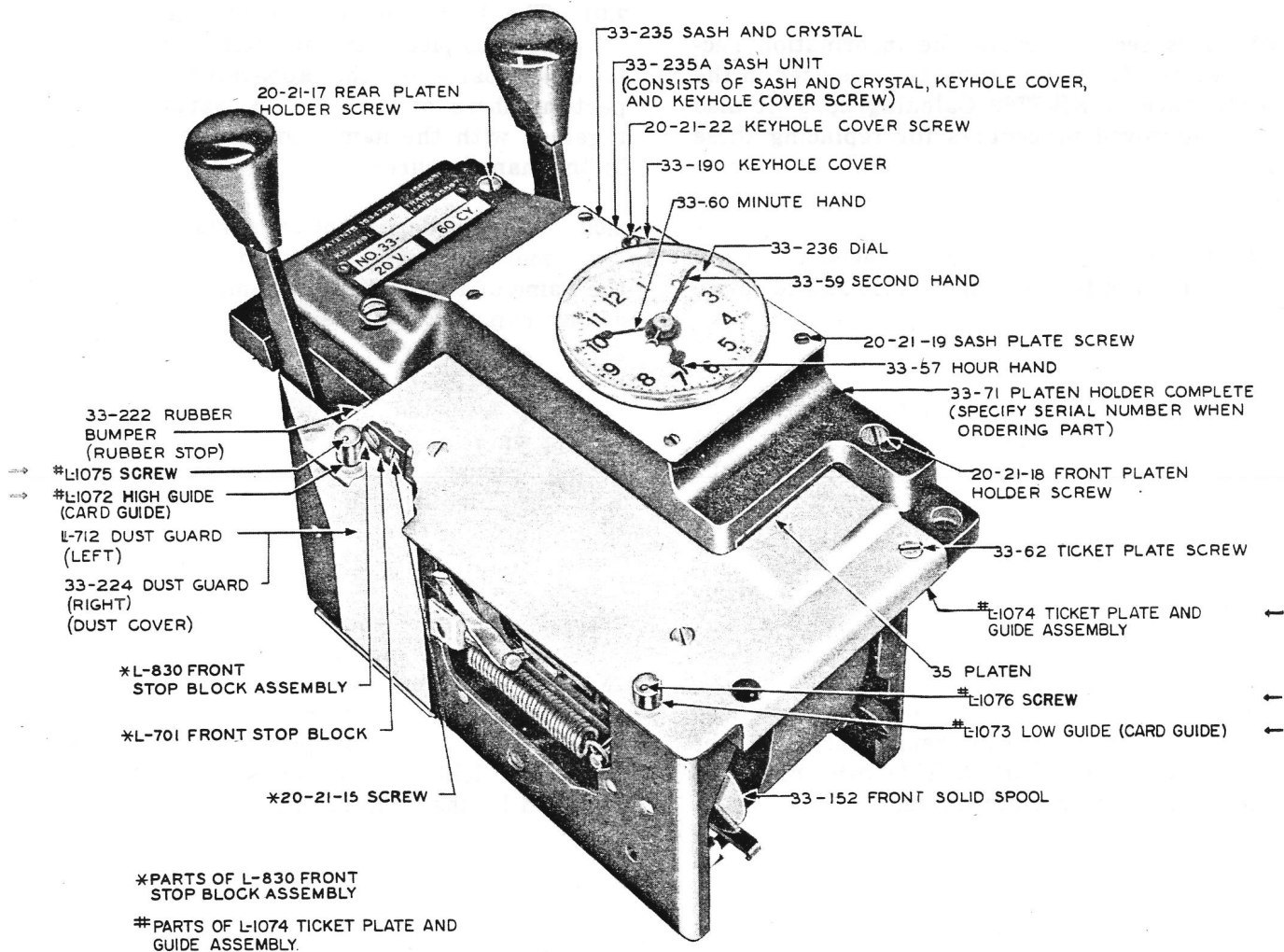
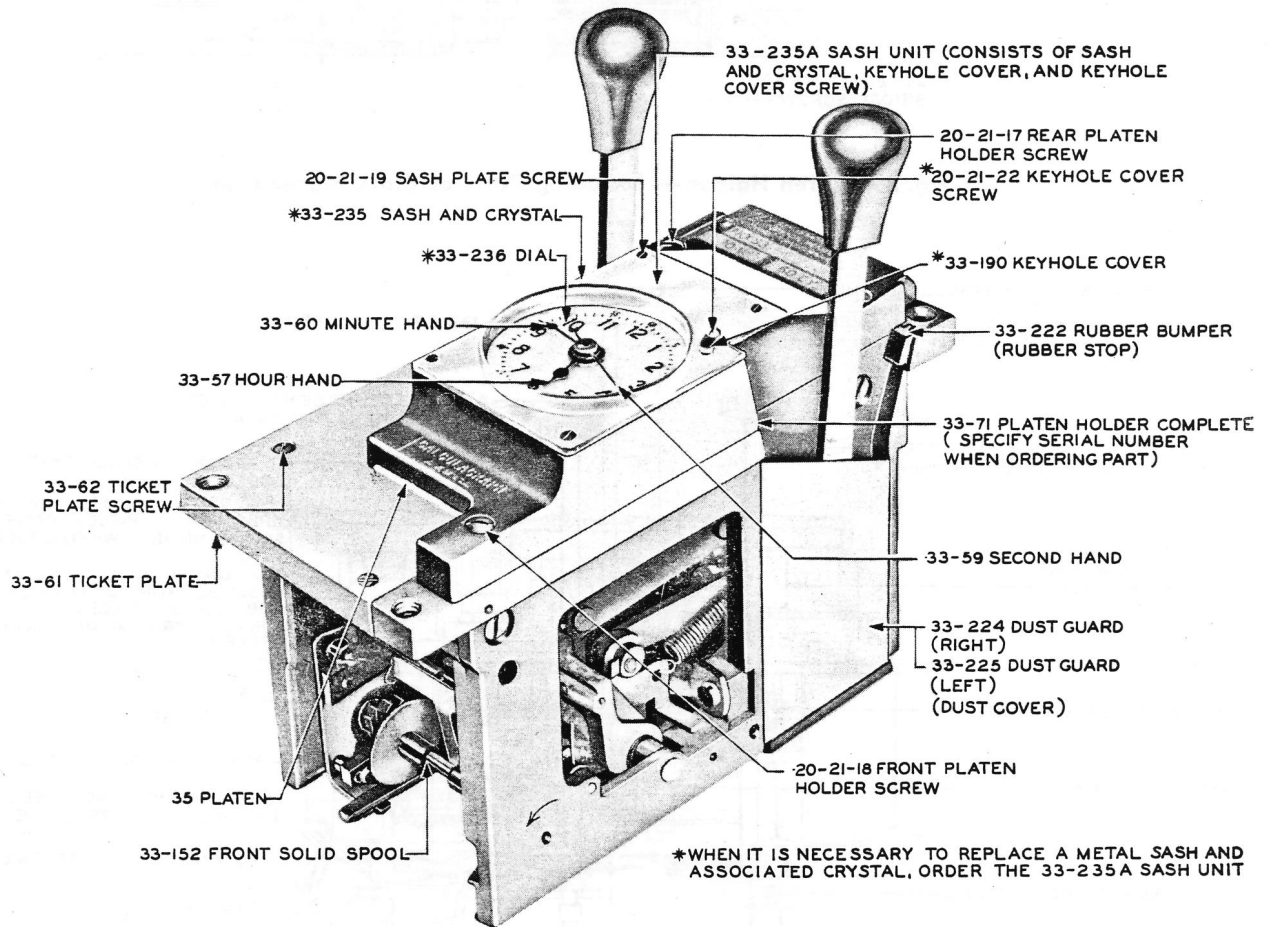

Fig. 1 – Ticket Plate, Platen Holder, and Associated Parts (KS-7769, L14 Calculagraph Illustrated)



**Fig. 2 – Ticket Plate, Platen Holder, and Associated Parts (KS-7769, L8 Calculagraph Illustrated)**

FOR OTHER PARTS OF PLATEN HOLDER ORDER  
33-71 PLATEN HOLDER COMPLETE  
(SPECIFY SERIAL NUMBER  
WHEN ORDERING PART)

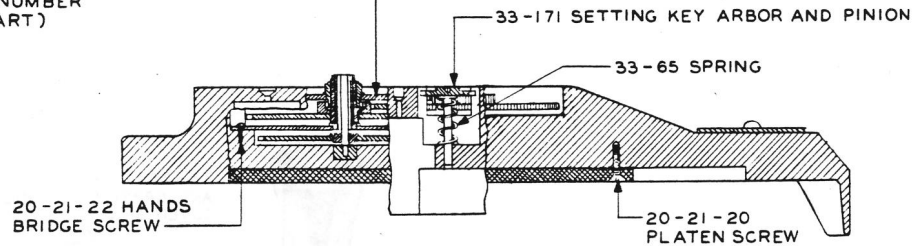
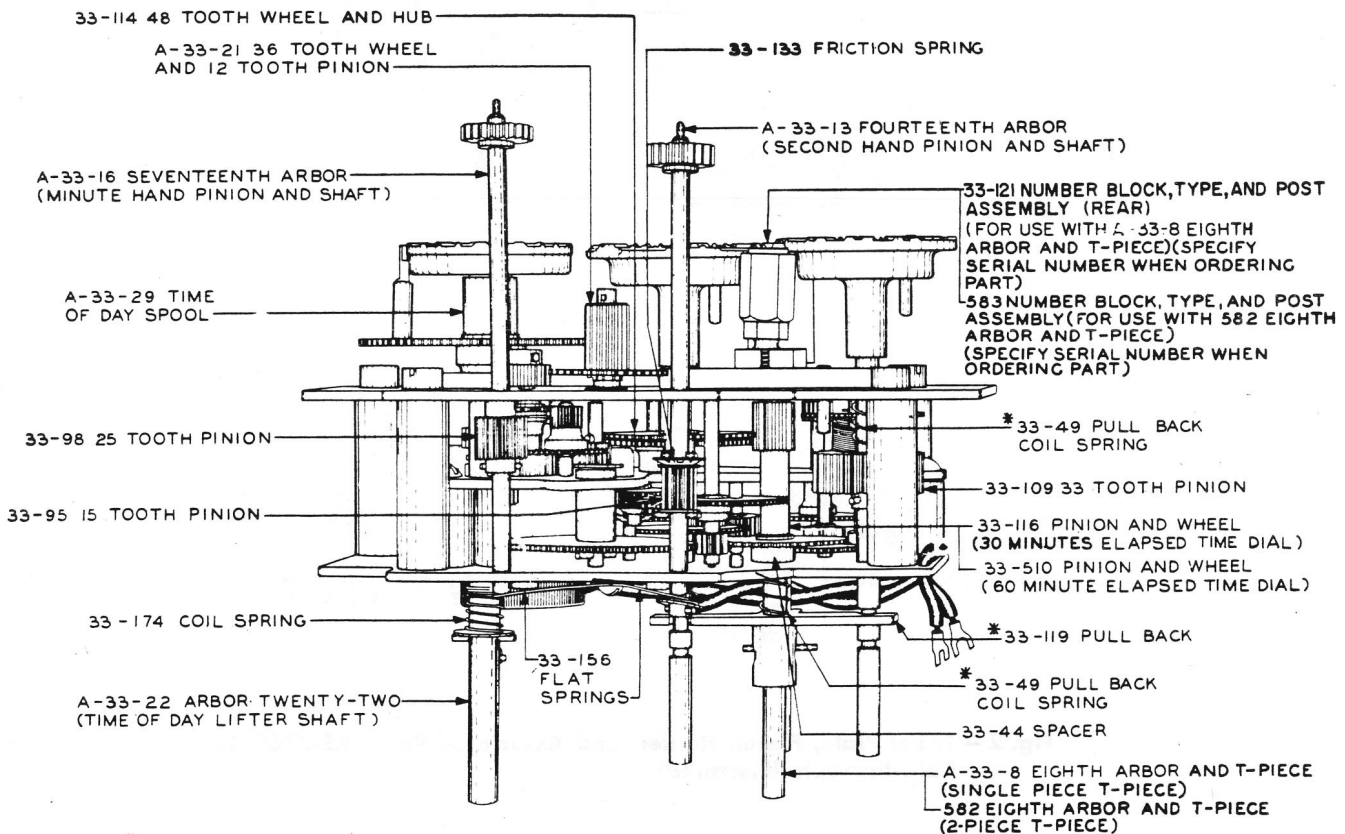

Fig. 3 — Platen Holder — Including Parts of Clock Mechanism



\* IN LATER MODEL CALCULAGRAPHS, ONE 33-119 PULLBACK AND TWO 33-49 PULLBACK COIL SPRINGS, AS SHOWN IN FIG. 4, AND ONE 33-175 MINUTES ARBOR DRAG SPRING, AS SHOWN IN FIG. 6, ARE REPLACED BY THREE 18D COIL SPRINGS, MOUNTED DIRECTLY BELOW THE BOTTOM CLOCK PLATE, ON THE ARBORS. THE ARBORS OF THE LATER MODEL ARE NOT GROOVED BELOW THE BOTTOM CLOCK PLATE, BUT ARE FURNISHED WITH PINS TO HOLD THE SPRINGS IN PLACE.

Fig. 4 — Clock and Stamping Mechanism

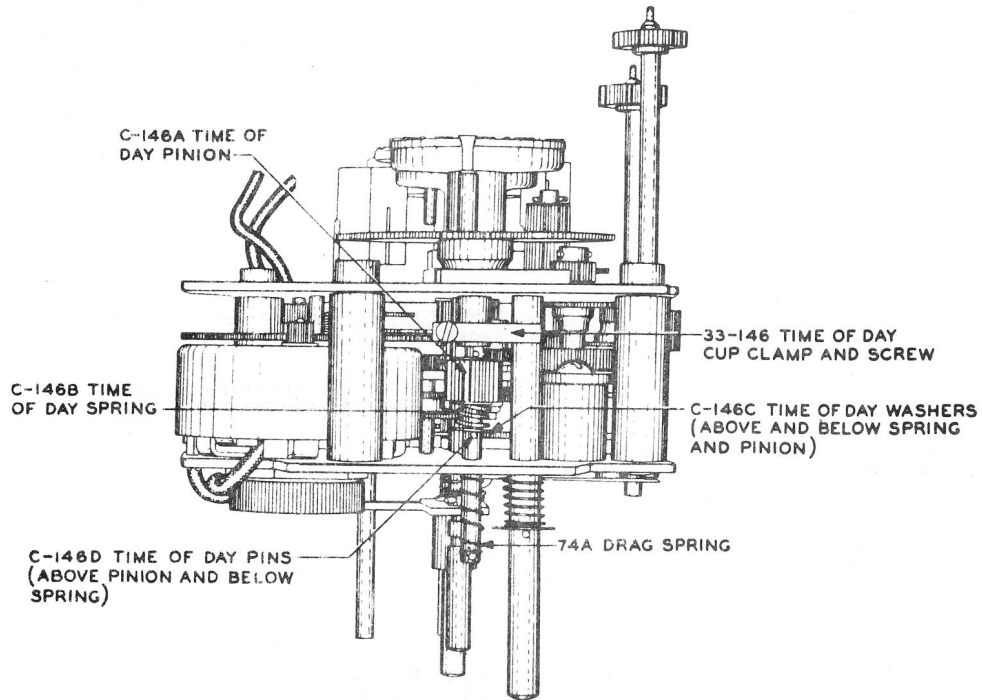
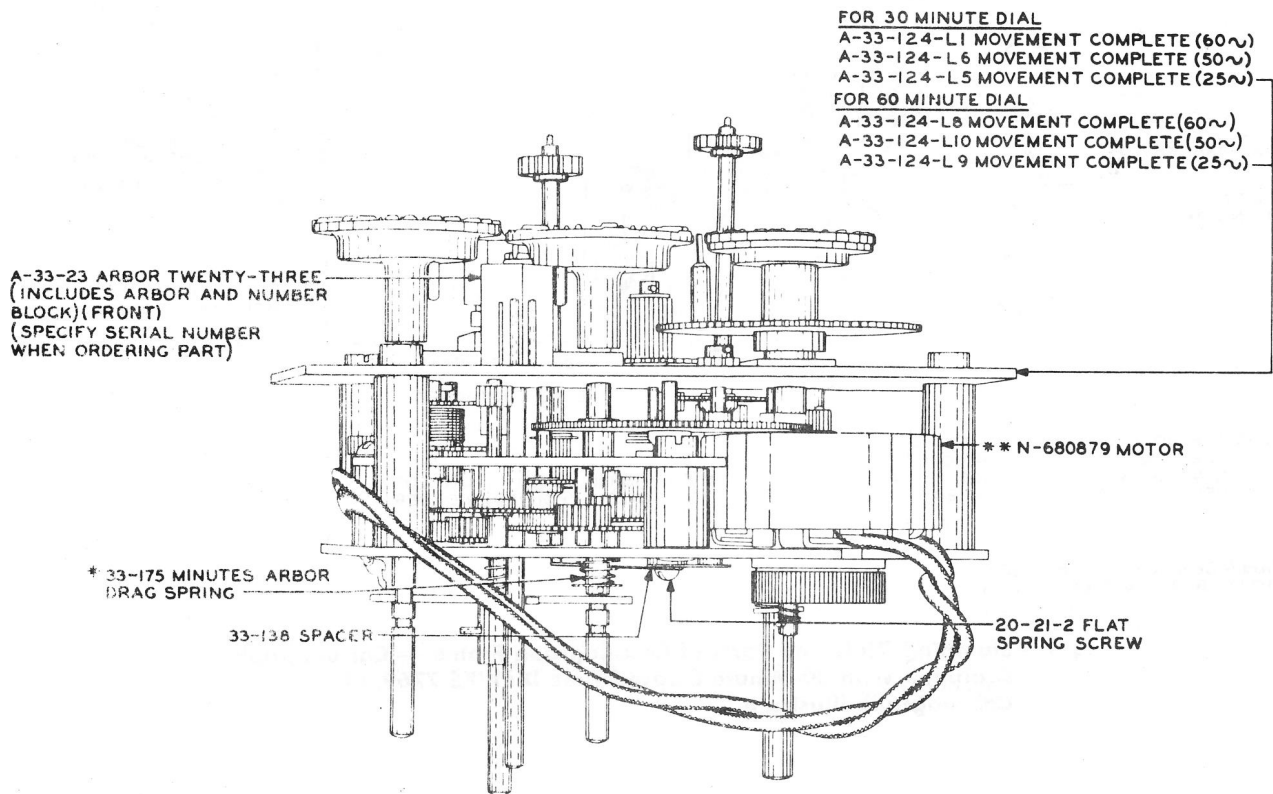

Fig. 5 – Synchronizing Attachment and Associated Parts



- \* SEE NOTE UNDER FIG. 4
- \*\* WHEN ORDERING N-680879 MOTOR SPECIFY 20V-60~ OR 20V-50~ OR 20V-25~

Fig. 6 – Motor Mechanism and Other Parts

**SECTION 030-102-801**

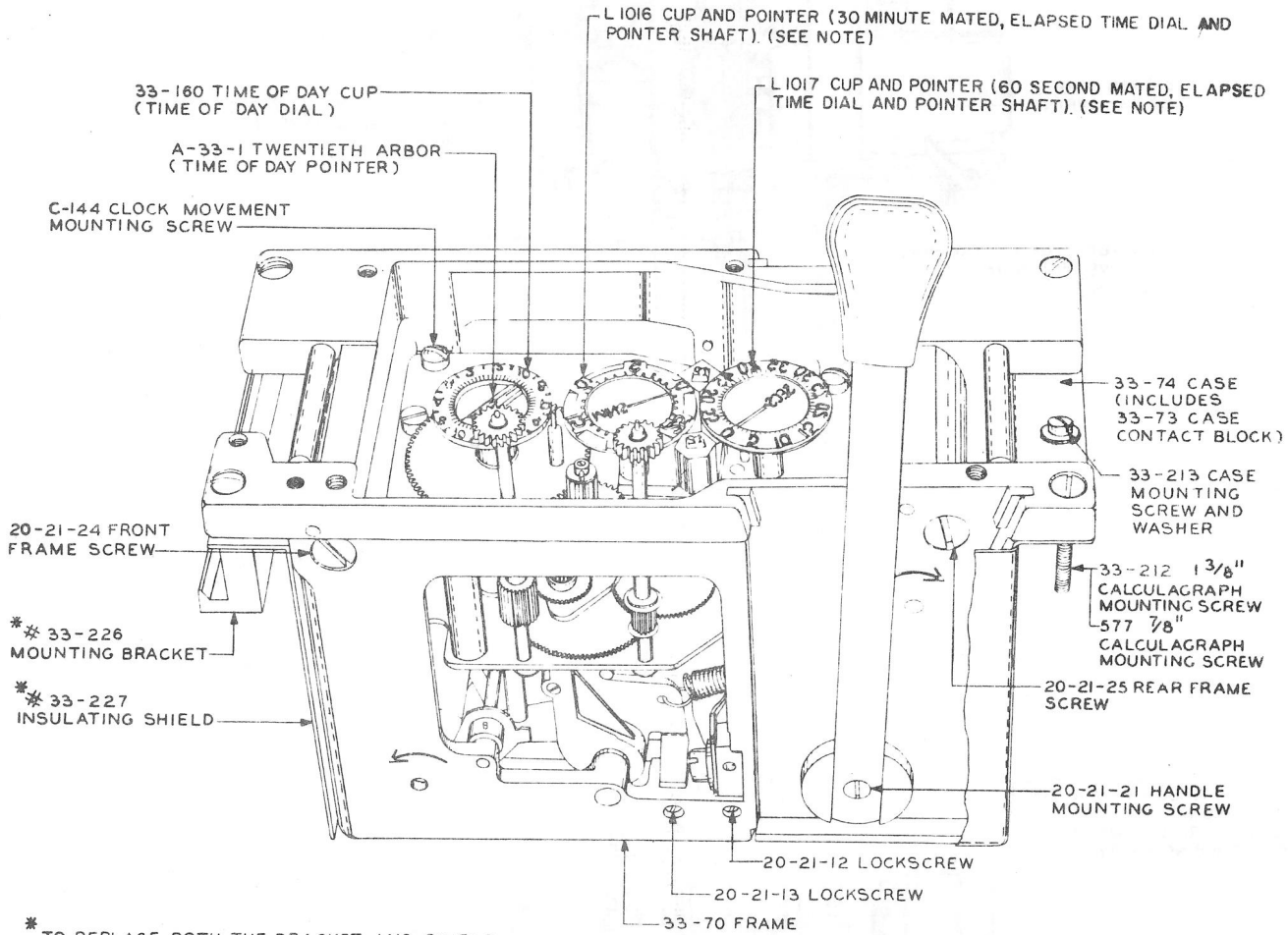

\* TO REPLACE BOTH THE BRACKET AND SHIELD, ORDER 33-226-227 MOUNTING BRACKET ASSEMBLY, WHICH WILL BE FURNISHED IN PAIRS UNLESS OTHERWISE SPECIFIED IN ORDER.

\* FURNISHED IN PAIRS UNLESS OTHERWISE SPECIFIED IN ORDER.

NOTE: WHEN REPLACING EITHER CUP OR POINTER REPLACE BOTH PARTS.

**Fig. 7 — Stamping Dials and Parts of Calculagraph Frame — Calculagraph Equipped With 30-Minute Elapsed-Time Dial (KS-7769, L1 Calculagraph Illustrated)**

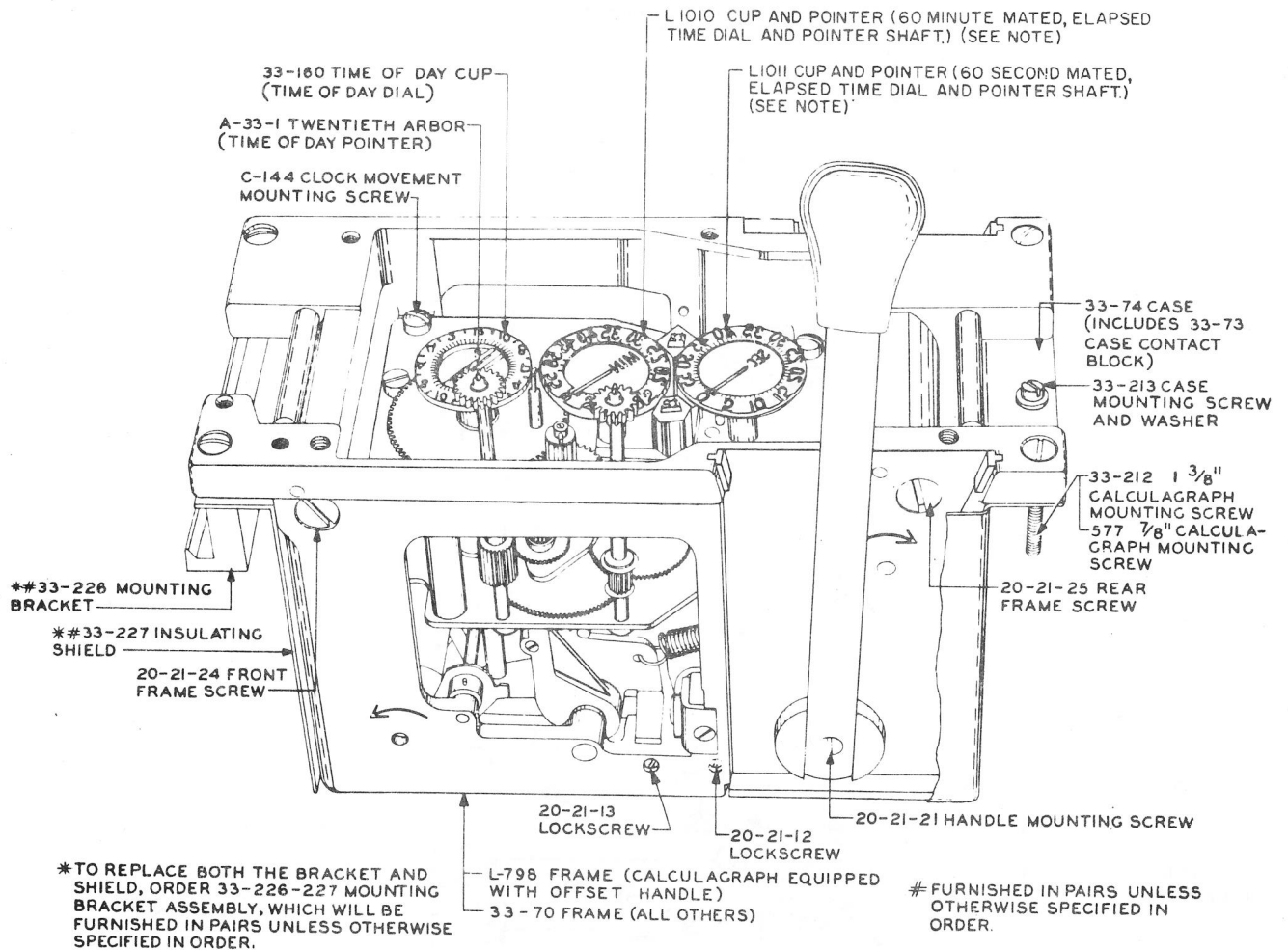

NOTE:  
WHEN REPLACING EITHER CUP OR POINTER REPLACE BOTH PARTS.

**Fig. 8 – Stamping Dials and Parts of Calculagraph Frame — Calculagraph Equipped With 60-Minute Elapsed-Time Dial (KS-7769, L11 Calculagraph Illustrated)**

SECTION 030-102-801

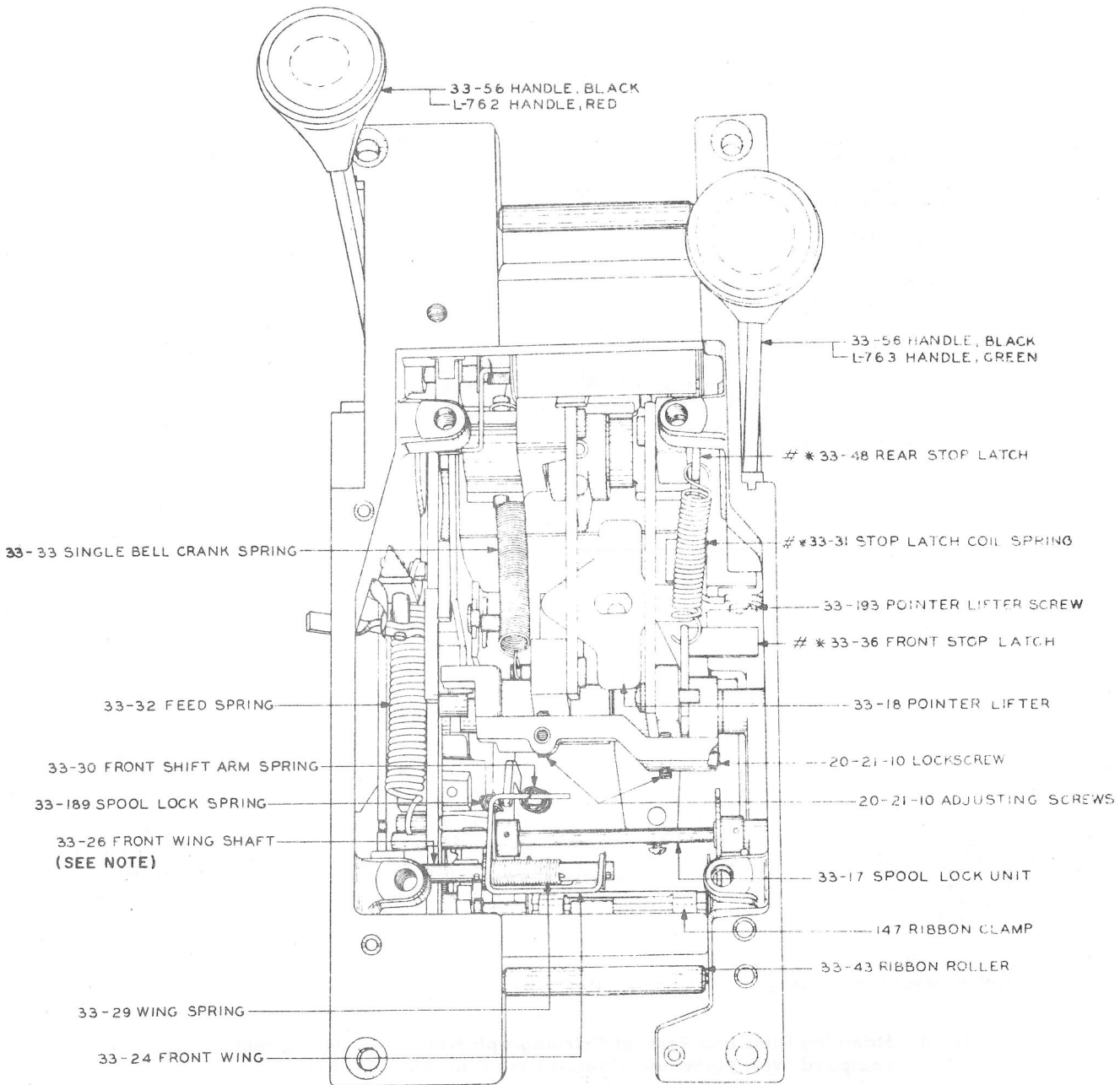

\* PARTS OF 33-28 LEVER MECHANISM. (KS-7769 L1, L5, L6, L8, L9 & L10 CALCULAGRAPHS)  
ORDER INDIVIDUAL PARTS AS REQUIRED. SEE FIG. 10

# PARTS OF L762 LEVER MECHANISM. (KS-7769 L11 TO L16 CALCULAGRAPHS)  
ORDER INDIVIDUAL PARTS AS REQUIRED. SEE FIG. 10

NOTE: LATER TYPE 33-26 FRONT WING SHAFT IS NOT EQUIPPED WITH TAPER PINS FOR HOLDING THE FRONT WING IN PLACE BUT IS FURNISHED WITH TWO L-607 RETAINING RINGS

Fig. 9 - Ribbon Reverse Mechanism and Lever Mechanism (KS-7769, L11  
Calculagraph Illustrated)



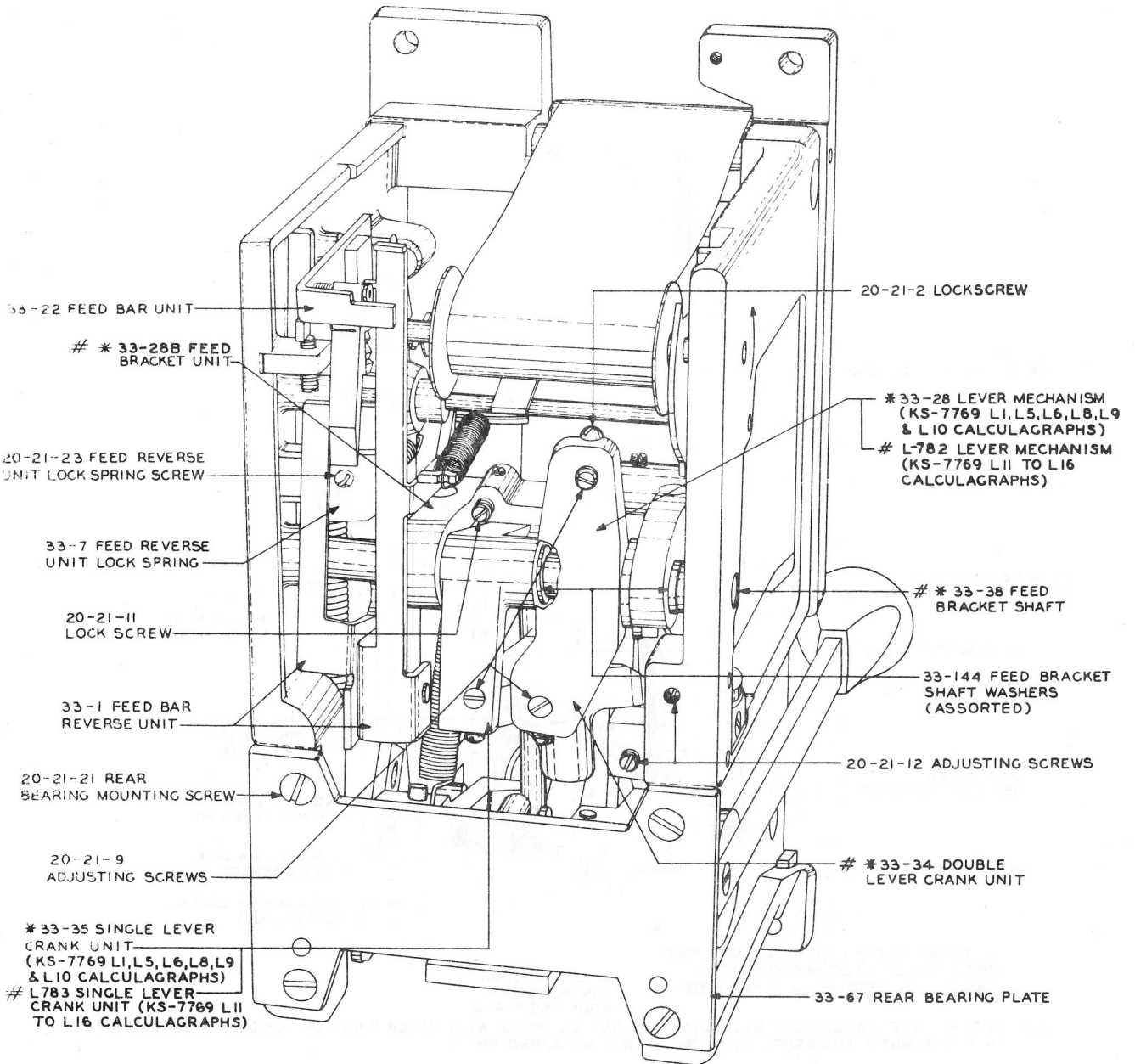

\* PARTS OF 33-28 LEVER MECHANISM. (KS-7769 L1, L5, L6, L8, L9, & L10 CALCULAGRAPHS). ORDER INDIVIDUAL PARTS AS REQUIRED.  
 # PART OF L782 LEVER MECHANISM. (KS-7769 L11 TO L16 CALCULAGRAPHS). ORDER INDIVIDUAL PARTS AS REQUIRED.

Fig. 10 - Ribbon Reverse Mechanism, Lever Cranks, and Associated Parts

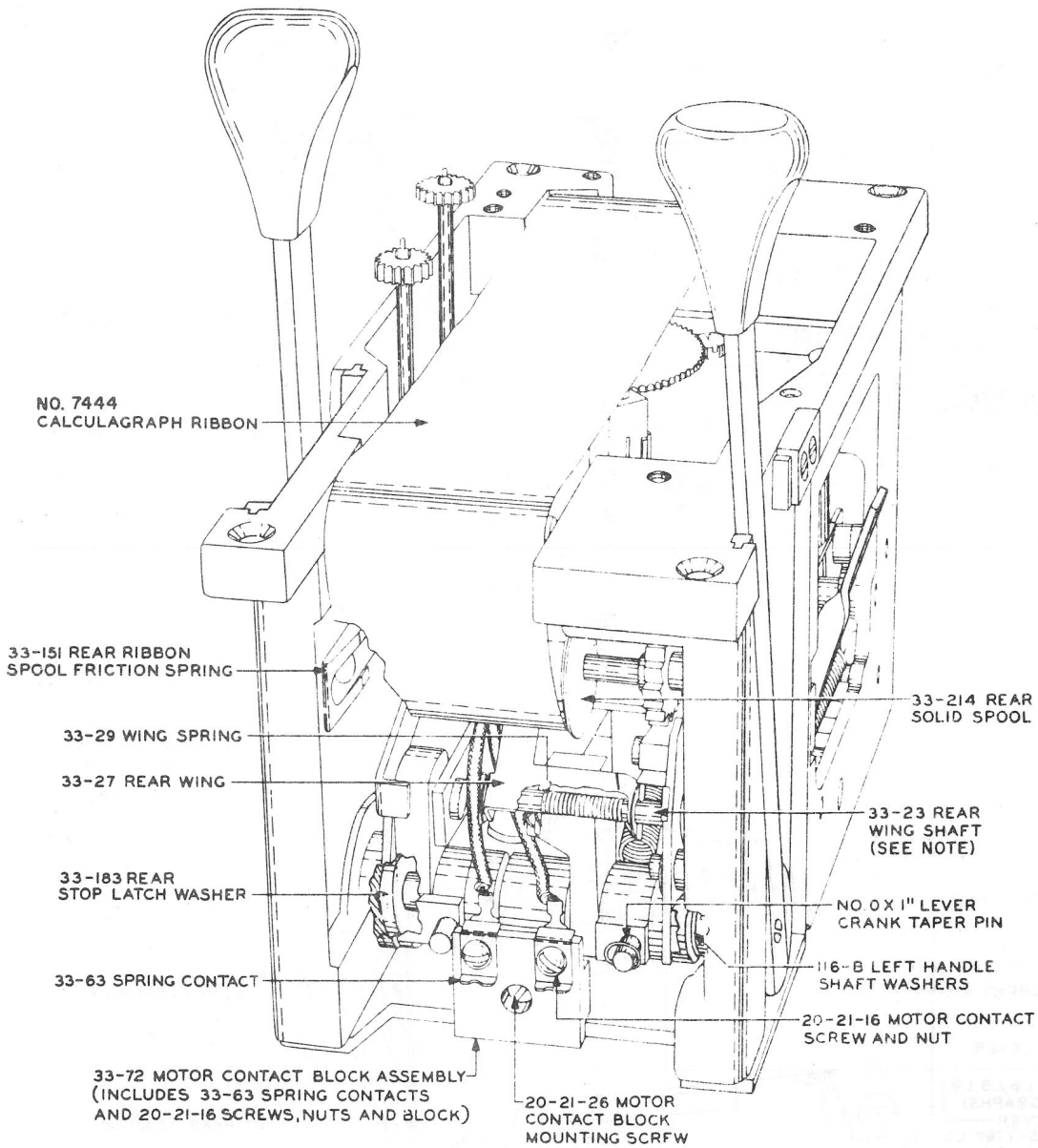

NOTE: LATER TYPE 33-23 REAR WING SHAFT IS NOT EQUIPPED WITH TAPER PINS FOR HOLDING THE REAR WING IN PLACE BUT IS FURNISHED WITH TWO L-607 RETAINING RINGS.

Fig. 11 - Rear View of Calculagraph (KS-7769, L11 Calculagraph Illustrated)

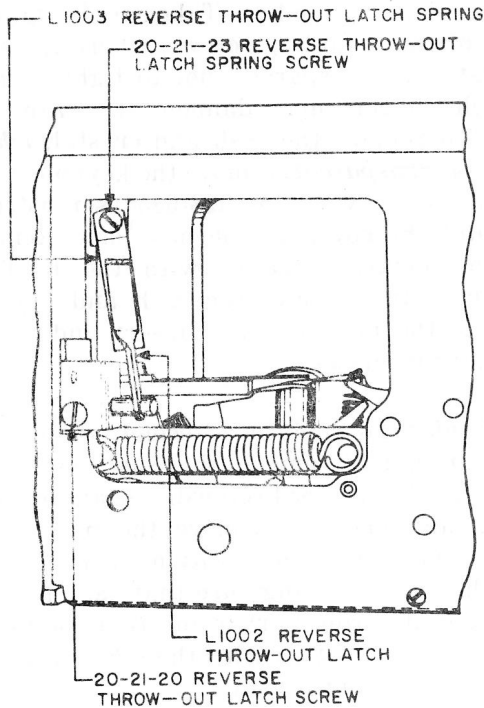

Fig. 12 -- Reverse Throw-Out Latch Mechanism (Later-Type Reverse Throw-Out Latch Illustrated)

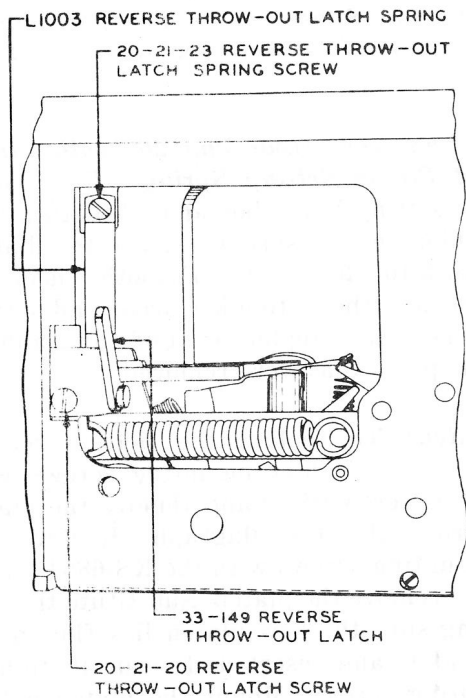

Fig. 13 -- Reverse Throw-Out Latch Mechanism (Earlier-Type Reverse Throw-Out Latch Illustrated)

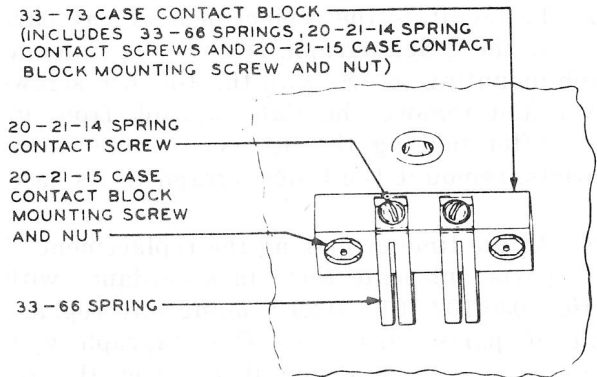

Fig. 14 -- Case Contact Block and Associated Parts

### 3. REPLACEMENT PROCEDURES

#### 3.01 List of Tools and Materials

CODE OR SPEC NO.	DESCRIPTION
<b>TOOLS</b>	
417A	1/4- and 3/8-Inch Open Double-End Flat Wrench
485A	Smooth-Jaw Pliers
573A	3/4-Inch Hex. Single-End Box Wrench
KS-6854	3-1/2 Inch Screwdriver
KS-7769,L3	Ribbon Winding Key
R-1005	Jewelers Screwdriver
—	4-Ounce Riveting Hammer
—	3/32-Inch Drive Pin Punch, L. S. Starrett Co, No. 565 (or equivalent)
—	5-Inch Diagonal Pliers
—	3-Inch C Screwdriver (or the replaced 3-inch cabinet screwdriver)
—	4-Inch E Screwdriver (or the replaced 4-inch regular screwdriver)
—	E-15 Truarc Applicator, Waldes Kohinoor Inc
<b>MATERIALS</b>	
—	Pliobond Adhesive No. 30, Obtained Locally or From Bond Adhesive Co, 120 Johnston Ave, Jersey City, N. J.

## SECTION 030-102-801

**3.02** To facilitate the replacement of any part of the Calculagraph, remove the Calculagraph mounting screws with the 4-inch E screwdriver and remove the Calculagraph from its case. After making the necessary replacement of parts, remount the Calculagraph in its case.

**3.03** At the time of making the replacement of parts, lubricate them in accordance with Section 030-102-701. After making any replacement of parts, check the Calculagraph and, where necessary, readjust it to meet the requirements specified in the section mentioned above.

**3.04** No replacement procedures are specified for screws or other small parts when the replacement consists of a simple operation.

**3.05** If, in effecting the replacement of any part, it has been necessary to stop the clock, check the hands of the clock with the time recorded by the time-of-day stamp for synchronization as covered in Section 030-102-701.

### **Ticket Plate**

**3.06 Ticket Plate:** To replace the ticket plate, remove the ticket plate mounting screws with the KS-6854 screwdriver and remove the ticket plate. Substitute the new part and insert and securely tighten the mounting screws.

### **Platen Holder and Associated Parts**

**3.07 Keyhole Cover:** To replace the keyhole cover, remove the cover mounting screw with the KS-6854 screwdriver and remove the cover. Substitute the new part and insert and securely tighten the cover mounting screw.

**3.08 Sash and Crystal:** To replace the sash and crystal, *where the sash is metal*, it will also be necessary to replace the keyhole cover and the dial. Remove the sash mounting screws with the KS-6854 screwdriver and remove the sash and crystal. Remove the hands as covered in 3.09 and remove the dial. Substitute the new dial in place and remount the hands as covered in 3.09. Mount the new sash and crystal, which is transparent, in place and insert and tighten the mounting screws. Mount the new key-

hole cover securely in place. Take care in tightening any of the mounting screws, where the sash and crystal is transparent, not to tighten them too much as this may damage the sash and crystal. To replace the sash and crystal, *where the part is transparent*, remove the keyhole cover mounting screw with the KS-6854 screwdriver and mount the cover on the new part. Remove the sash mounting screws with the KS-6854 screwdriver and remove the sash and crystal. Substitute the new part and insert and secure the mounting screws.

**3.09 Hands:** To replace a second, minute, or hour hand, remove the sash mounting screws with the KS-6854 screwdriver and remove the sash and crystal. Remove the hands and make the necessary substitution of parts. Remount the parts, making sure that each hand is mounted on its proper arbor and that the hands do not interfere with each other. Securely remount the sash and crystal.

**3.10 Dial:** To replace the dial associated with a metal sash, proceed as covered in 3.08. To replace the dial, where the sash is transparent, remove the hands as covered in 3.09 and remove the dial. Substitute the new part and remount the parts that were removed as covered in 3.09.

**3.11 Setting Key Arbor and 20-Tooth Pinion and Pinion Setting Spring:** To replace either the setting key arbor and 20-tooth pinion or the pinion setting spring, remove the dial as covered in 3.10. Remove the 75-tooth wheel and hub and remove the setting key arbor and spring. Make the necessary replacement of parts and remount the parts that were removed.

**3.12 Platen:** To replace the platen, remove the platen holder mounting screws with the 3-inch C screwdriver and remove the platen holder from the Calculagraph. Remove the platen mounting screws with the KS-6854 screwdriver and remove the platen. Substitute the new part, being sure the new platen lies flat in the platen holder, and insert and securely tighten the mounting screws. Mount the platen holder securely on the frame, inserting the shortest mounting screw in the hole at the front and the two other screws in the holes at the rear.

Test the Calculagraph to see if a dark, sharp, and even stamp is obtained on the ticket. If such is not the case, consider banking the platen holder to produce the proper imprint on the ticket.

**3.13 Platen Holder and Other Associated Parts:** If the platen holder or any of the gears of the clock train mounted in the platen holder are defective, refer the matter to the supervisor.

**Note:** When replacing a platen holder where the new holder has two studs but the frame has only one hole for a stud, proceed as follows. Remove the extra stud by putting it in a vise and rotating and pulling up on the holder.

#### **Clock Movement and Associated Parts**

**3.14 General:** Remove the ticket plate and platen holder as covered in 3.06 and 3.12, respectively. Loosen the spring contact on the motor connecting block and remove the wires from the block. Remove the clock movement mounting screws with the 4-inch E screwdriver and remove the clock movement from the frame. After the replacements have been made, remount the parts in the reverse order.

**3.15 Motor:** To replace the motor, pull the wires through the bottom plate of the clock movement. Remove the knurled cap from the bearing assembly. Remove the bearing assembly with the No. 573A wrench and remove the motor from the clock plate. Remove the bearing assembly from the new motor and remove the knurled cap from the bearing assembly. Make sure that the new motor is adequately lubricated. Mount the motor on the clock plate and engage the pinion on the rotor with the teeth of the associated gear. Mount the bearing assembly over the shaft. Do not tighten the bearing assembly. To insure good alignment of the parts, engage the teeth of the gear and pinion at least 1/2 the depth of the teeth but not the full depth. Then, while holding the parts in position, securely tighten the bearing assembly. Mount and securely tighten the knurled cap.

**3.16 Front Number Block and Shaft:** To replace either the front number block or shaft, replace the parts as an assembly. Lift the assembly through the upper plate of the clock movement. Make the necessary substitution of parts and insert the assembly down through the upper and lower plates of the clock movement. After the apparatus is reassembled, check that a satisfactory impression of the number block is obtained. If it is not, raise or lower the number block on the shaft as required.

**3.17 Pullback and Spring:** To replace either the pullback or spring, remove the taper pin that extends through the pullback collar and the shaft with the No. 485A pliers. Rotate the pullback so as to clear the other shafts and remove the pullback and spring. Make the necessary substitution of parts and mount the spring and pullback in place. Insert the taper pin through the pullback collar and shaft. In the later model Calculagraphs, where the pullback has been omitted, use the No. 485A pliers to remove the three pins which are located beneath the bottom clock plate on the arbors. Then, remove the helical springs. Make the necessary substitution of parts and remount the springs and pins in place.

**3.18 Elapsed-Time Cup and Pointer (60 Seconds) and 33-Tooth Pinion:** To replace the elapsed-time cup (dial) and pointer (pointer shaft) or 33-tooth pinion, proceed as follows. Remove the pullback as covered in 3.17. Remove the pin that secures the pinion in place with the No. 485A pliers. If the pinion or associated spring is to be replaced, hold the pinion and raise the pointer shaft up through the upper plate of the clock movement far enough to remove the pinion and, if necessary, the spring. Substitute the new part on the shaft and lower the shaft in place. Mesh the pinion with its associated gear so that the holes in the pinion and shaft are in alignment and are in such a position that the holes are accessible. Insert the pin through the holes to secure the parts in place. If either the cup (dial) or pointer (pointer shaft) is to be replaced, replace the parts as a fitted unit consisting of a mated cup and pointer. To replace the cup and pointer, proceed as covered above, except that the shaft is entirely removed through the upper plate. Substitute the

new mated parts and insert the pointer shaft down through the plate and mount, mesh, and align the pinion and shaft as covered above. Remount the pullback and spring as covered in 3.17. After assembly of the Calculagraph, test to see if a dark, sharp, and even stamp is obtained on the ticket. If such is not the case, consider banking the platen holder to produce the proper imprint on the ticket.

**3.19 Elapsed-Time Cup and Pointer (30 or 60 Minutes), and 48-Tooth Wheel:** To replace the elapsed-time cup (dial) and pointer (pointer shaft) or 48-tooth wheel, proceed as follows. Remove the pullback and spring as covered in 3.17. Remove the pin that holds the shaft spring in place with the No. 485A pliers and remove the washer and spring. If necessary, replace the spring at this time. Remove the pin that secures the wheel in place with the No. 485A pliers. If the wheel is to be replaced, hold the wheel and raise the pointer shaft up through the upper plate of the clock movement far enough to remove the wheel. Remove the wheel from the clock movement. Substitute the new part on the shaft and lower the shaft in place. Mesh the wheel with its associated gear so that the holes in the wheel and shaft are in alignment and are in such a position that the holes in the shaft and wheel are accessible. Insert the pin through the holes to secure the parts in place. If either the cup (dial) or pointer (pointer shaft) is to be replaced, replace the parts as a fitted unit consisting of a mated cup and pointer. To replace the cup and pointer, proceed as covered above, only, in this case, the shaft is entirely removed from the clock plate. Substitute the new mated parts and insert the pointer shaft down through the plate and mount the wheel on the shaft as covered above. Mount the shaft spring and washer on the shaft and insert the taper pin. Remount the pullback and spring as covered in 3.17. After assembly of the Calculagraph, test to see if a dark, sharp, and even stamp is obtained on the ticket. If such is not the case, consider banking the platen holder to produce the proper imprint on the ticket.

**3.20 Rear Number Block, Type, and Post Assembly:** To replace the rear number block, type, and post assembly, remove the block and post assembly from the elapsed-time lifter

with the No. 417A wrench. Mount the new block and post assembly in place on the elapsed-time lifter.

**3.21 Elapsed-Time Dial T-Piece, Pinion and Wheel, and T-Piece Spacer:** To replace the elapsed-time dial T-piece, pinion and wheel, or T-piece spacer, proceed as follows. Remove the pullback and spring as covered in 3.17 and the elapsed-time dial assemblies (30 or 60 minutes and 60 seconds) as covered in 3.18 and 3.19. If the T-piece spacer or pinion and wheel is to be replaced, raise the shaft of the elapsed-time dial T-piece enough so that the part may be removed. If the T-piece is to be replaced, raise it until it clears the upper plate of the clock movement. Take care not to lose the washer mounted above the pinion and wheel. Remove the rear number block and post from the T-piece using the No. 417A wrench. Mount the block and post on the new T-piece and insert the assembly down through the upper plate. Locate the washer, wheel and pinion, and T-piece spacer in place and insert the shaft down through the parts. Remount the elapsed-time dial assemblies as covered in 3.18 and 3.19 and then the pullback and spring as covered in 3.17.

**3.22 Flat-Type Arbor Springs and Spacer:** To replace either of the flat-type arbor springs or the spacer, remove the spring-mounting screw with the KS-6854 screwdriver and remove the defective part. Make the necessary substitution of parts and insert and securely tighten the mounting screw. Place each spring under its associated arbor to hold it in position.

**3.23 Second-Hand Pinion and Shaft and Assembly:** To replace the rear number pinion and shaft or any of the associated parts, proceed as follows. Slide the flat-type shaft spring away from the end of the shaft. Remove the taper pins from the shaft with the No. 485A pliers. Raise the second-hand pinion and shaft through the lower plate of the clock movement. If the 15-tooth pinion, associated washers, or spring is to be replaced, it will not be necessary to remove the shaft from the clock movement; merely raise the shaft enough to slip off the defective part. Make the necessary substitution of parts. If the pinion and shaft is to be replaced, remove it through the upper plate. Take

care not to lose the 15-tooth pinion or associated parts. Substitute the new part and insert the shaft down through the upper plate of the clock movement. Mount the parts on the shaft in the following order: first a small washer, then the tension spring, the large washer, the 15-tooth pinion, and then the other small washer. Insert a taper pin through the upper hole in the shaft, then, while compressing the spring, insert the other taper pin through the lower hole so that the parts are held in place between the two taper pins and the pinion is in mesh with its associated wheel. Slide the flat-type shaft spring into place.

**3.24 Minute-Hand Pinion and Shaft and 25-Tooth Pinion:** To replace the minute-hand pinion and shaft or the 25-tooth pinion, proceed as follows. Slide the flat-type shaft spring away from the end of the arbor. Remove the taper pin from the shaft with the No. 485A pliers. Raise the minute-hand pinion and shaft through the lower plate of the clock movement. If the 25-tooth pinion is to be replaced, it will not be necessary to remove the shaft from the clock movement; merely raise the shaft enough so that the pinion may be slipped off. Replace the pinion with a new one if the pinion being removed is defective. If the pinion and shaft is to be replaced, remove it through the upper plate. Substitute the new part and insert the shaft down through the upper plate. Mount the 25-tooth pinion on the shaft with the solid collar toward the top. Align the holes in the collar with the holes in the shaft and insert the taper pin through the parts. Slide the flat-type shaft spring into place.

**3.25 Time-of-Day Drag Spring:** To replace the time-of-day drag spring, remove the taper pin from the shaft with the No. 485A pliers and remove the spring. Substitute the new part and insert the taper pin in place.

**3.26 Synchronizing Attachment and Time-of-Day Pointer:** To replace any part of the synchronizing attachment or the time-of-day pointer, remove the time-of-day drag spring as covered in 3.25 and proceed as follows. Remove the taper pins from above and below the time-of-day pinion. If any part of the synchronizing attachment is to be replaced, raise the time-of-day

pointer shaft enough beyond the lower plate of the clock movement to permit the removal of the washers, compression spring, or time-of-day pinion as required. Make the necessary replacement of parts and reassemble the parts in the reverse order from which they were removed. If the entire assembly was removed, proceed as follows. Place one washer over the end of the pointer shaft, then the pinion, another washer, the compression spring, and another washer. Insert the shaft through the lower plate and place the shaft spring and washer over the end of the shaft. Insert the taper pins through the hole near the end of the shaft and the hole nearest the upper plate. Mesh the teeth of the pinion with its associated gear. Compress the compression spring by placing the thumb of one hand under the washer that is beneath the spring and raise the entire assembly until the other taper pin can be inserted in the hole in the shaft beneath the lowest washer. If the pin is too long, cut it off to a satisfactory length with the diagonal pliers. To replace the time-of-day pointer, remove the parts mounted on the shaft as covered above and remove the pointer shaft through the upper plate of the clock movement. Substitute the new part and insert the shaft down through the upper plate and reassemble the parts on the shaft as covered above.

**3.27 Time-of-Day Dial, Clamping Collar, and Time-of-Day Spool and Triangle:** To replace the time-of-day dial, clamping collar, or time-of-day spool and triangle, remove the time-of-day pointer as covered in 3.26. Loosen the clamping collar setscrew with the KS-6854 screwdriver and remove the clamping collar from the time-of-day dial shaft. Remove the dial and spool as required. Make the necessary replacement of parts and reassemble them in place on the upper plate. Mount the clamping collar on the time-of-day shaft and secure it in place. Reassemble the time-of-day pointer and associated parts as covered in 3.26. Check the time-of-day dial and pointer shaft for bind and, if they appear to bind, back off the clamping screw with the KS-6854 screwdriver from 1/4 to 1/2 turn. After assembly of the Calculagraph, test to see if a dark, sharp, and even stamp is obtained on the ticket. If such is not the case, consider banking the platen holder to produce the proper imprint on the ticket.

**3.28 Time-of-Day Lifter:** To replace the time-of-day lifter, remove the time-of-day dial and spool and triangle as covered in 3.27. Remove the taper pin from the time-of-day lifter shaft with the No. 485A pliers and remove the washer and spring. Remove the lifter from the clock movement. Substitute the new part and mount it through the clock movement. Mount the shaft spring and washer in place and insert the taper pin through the shaft. Reassemble the other parts that were removed as covered in 3.27.

**3.29 36-Tooth Wheel and 12-Tooth Pinion:** To replace the 36-tooth wheel and 12-tooth pinion, remove the time-of-day lifter as covered in 3.28. Remove the taper pin in the shaft of the 36-tooth wheel and 12-tooth pinion with the No. 485A pliers. Remove the washer and the wheel and pinion. Substitute the new part, remount the washer, and insert the taper pin in the shaft. Remount the time-of-day lifter and other parts as covered in 3.28.

**Lever Mechanism, Ribbon Reverse Mechanism, and Associated Parts**

**3.30 Operating Levers:** To replace either operating lever, remove the lever mounting screw with the 4-inch E screwdriver. Substitute the new part and insert and securely tighten the mounting screw.

**3.31 Ribbon and Ribbon Clamps:** To replace an old or defective ribbon or ribbon clamp, remove the platen holder mounting screws with the 3-inch C screwdriver and remove the platen holder. Remove the ticket plate mounting screws with the KS-6854 screwdriver and remove the ticket plate. Remove the ribbon by withdrawing it upward so that it is unwound from both spools. Remove the ribbon clamps from the spools. If the clamps are old or defective, replace them at this time. Remove the new ribbon from the container and unroll about 12 inches. Replace the roll of ribbon in the container leaving the loose 12 inches of ribbon outside. Close or replace the cover, making sure that the ribbon is not twisted. Place the loose end of the ribbon over the front spool and secure it in place by placing the clamp over the ribbon and spool with the long, straight portion of the clamp upwards. Slide the clamp toward the left or right so that the prongs of the

clamp clear the slot in the spool. Wind all but 12 inches of the ribbon on the spool, using the KS-7769, L3 ribbon winding key. Pass the ribbon over the ribbon roller at the front end and draw it over the roller at the rear end and clamp it in place with the clamp. Wind it over the other ribbon spool, using the key. Take care in doing this not to twist the ribbon. Remount and securely tighten the ticket plate and platen holder.

**3.32 Front Ribbon Spool, Front Wing, and Associated Parts:** To replace the front ribbon spool, front wing, front shift arm spring, the retractile spring, or front shaft, proceed as follows. To replace the front ribbon spool, remove the ribbon from the spool as covered in 3.31 and push back the ribbon spool locking unit arms and remove the spool. Substitute the new part and rewind the ribbon. To replace the front shift arm spring, remove it from the wing arm and ribbon reverse mechanism and substitute the new part. To replace other parts, remove the three taper pins or the taper pin and two retaining rings, as furnished, from the front wing shaft with the No. 485A pliers. Unlatch the front shift arm spring and remove the washers, wing, and spring. If the shaft is to be replaced, remove it at this time and substitute a new one. Make sure that the shaft is firmly held in the frame of the Calculagraph. If it is not, place the 3/32-inch drive pin punch on the free end of the shaft and hit the punch sharply with the 4-ounce riveting hammer. If the retractile spring or wing is to be replaced, replace the part at this time. Remount the parts as follows. Loop the square bent end of the spring under the wing. Slide the washer, wing, and spring over the shaft and latch the front shift arm spring over the front wing arm. Place the other washer over the end of the shaft. When the shaft is arranged for three pins, insert the spring and wing taper pins through the shaft. When the shaft is arranged for one pin and two retaining rings, insert the spring taper pin through the shaft and mount the wing retaining rings using the E-15 Truarco applicator. Engage the free end of the retractile spring with the spring taper pin.

**3.33 Rear Wing and Associated Parts:** To replace the rear wing, the retractile spring, or rear shaft, proceed as covered in 3.32 except that there is insufficient space to use the pin



punch and what the wing is not connected to the ribbon reverse mechanism by means of a spring, but the arm is inserted in a slot in the mechanism.

**3.34 Ribbon Reverse Throw-Out Latch (Later Type) and Spring:** Fig. 12 — To replace a ribbon reverse throw-out latch, remove the latch mounting screw with the 3-inch C screwdriver and remove the latch. Substitute the new part and insert and securely tighten the mounting screw. To replace the ribbon reverse throw-out spring, remove spring mounting screw with the 3-inch C screwdriver and remove the spring. Substitute the new part and insert and securely tighten the mounting screw.

**3.35 Ribbon Reverse Throw-Out Latch (Earlier Type) and Spring:** Fig. 13 — If the earlier type throw-out latch is to be replaced, replace both the latch and the spring. If the spring is to be replaced, replace the spring only. To replace the parts, proceed as covered in 3.34. Make sure to position the spring so that the lower end of the spring is behind the throw-out latch as shown in Fig. 12 or 13 as applicable.

**3.36 Ribbon Feed Bar Spring:** To replace the ribbon feed bar spring, remove the spring from the ribbon feed bar with the No. 485A pliers and remove the pin from the ribbon feed bar mounting stud on the casting at the rear of the Calculagraph with the No. 485A pliers. Remove the washer and move the ribbon feed bar away from the casting. Remove the ribbon feed bar spring from the spring-mounting stud. Substitute the new part on the stud, remount the washer, and insert the pin through the mounting stud, securing the ribbon feed bar in place. Mount the other end of the spring on the ribbon feed bar.

**3.37 Operating Lever Spring:** To replace the operating lever spring, remove the spring from the stud on the single lever crank. Loop the closed end of the new spring under and around the rear crank and over the taper pin. Loop the other end around the stud on the front crank.

**3.38 Stop Connecting Spring:** To replace the stop connecting spring, open the end loops of the spring with the No. 485A pliers enough to remove the spring from the front and

rear stops. Substitute the new spring on the stops and close the loops to hold the spring in place.

**3.39 Elapsed-Time Pointer Lifter:** To replace the elapsed-time pointer lifter, remove the lifter mounting screw and washer with the 4-inch E screwdriver and slide the lifter out through the connecting links. Substitute the new part, sliding it down through the links. Insert the washer and screw through the lifter. Make sure that the lifter is centered over the adjusting screw on the double-lever crank and that the shoulder of the mounting screw is satisfactorily located through the washer and lifter. Then tighten the mounting screw securely in place.

**3.40 Reverse Unit Lock Spring:** To replace the reverse unit lock spring, remove the spring mounting screw with the 3-inch C screwdriver and remove the spring. Substitute the new part and insert and securely tighten the mounting screw.

**3.41 Motor Connecting Block and Associated Parts:** To replace a contact, remove the contact mounting screw and nut with the 3-inch C screwdriver and remove the contact. Substitute the new part and insert the mounting screw through the contact and connecting block. Mount the nut in place behind the block and securely tighten the mounting screw on the nut, holding the contact securely in place. To replace the motor connecting block, remove the block mounting screw with the 3-inch C screwdriver and remove the block. Substitute the new part and insert and securely tighten the mounting screw in place.

**3.42 Adjusting Screws and Setscrews:** To replace a setscrew, remove the screw with the R-1005 screwdriver. Substitute the new screw and tighten it securely in place. To replace an adjusting screw, loosen the setscrew. Note the position of the adjusting screw and then remove the adjusting screw with the R-1005 screwdriver. Substitute the new part and run it into approximately the position of the replaced screw. Tighten the setscrew securely in position.

**3.43 Lever Crankshaft, U-Bar, and Front Lever Stop:** To replace the lever crankshaft or front lever stop, proceed as follows. Note the

position of each part before removing the shaft. Remove the two taper pins with the No. 485A pliers. Remove the operating lever spring from the stud on the single-lever crank. Drive the shaft from the frame and through the parts with the 3/32-inch pin punch and 4-ounce riveting hammer. In doing this, apply the pin punch to the end of the shaft on the same side of the frame as the ribbon reverse throw-out latch is located. Take care in removing the shaft not to lose the two washers that were against the taper pins or the spacing washer between the double-lever crank and U-bar. Spread open the end of the stop connecting spring that is attached to the front stop with the No. 485A pliers and remove the spring. If the shaft, U-bar, or stop is to be replaced, make the necessary substitution of parts at this time. Reassemble the parts as follows. Insert the shaft through the right-hand side of the frame. The end of the shaft to be inserted is the end nearer the two holes through the shaft. Mount the parts on the shaft as follows, driving the shaft through the part after it has been located on the shaft: one arm of the U-bar, the front stop, the double-lever crank, the spacing washer, the single-lever crank, the other arm of the U-bar, and then the two washers. Then drive the shaft through the other frame. Insert the two taper pins through the shaft to hold the washers against the part with which each is associated. Connect the stop connecting spring to the frontstop and close the end of the spring. Loop the operating lever spring over the stud on the single-lever crank.

**3.44 Handle Bearings, Rear Lever Stop, Lever Crank Units, and Rear Bearing Plate:** To replace a handle bearing, the rear lever stop, a single- or double-lever crank unit, or rear bearing plate, proceed as follows. Remove the lever crankshaft as covered in 3.43 and remove the operating lever spring from the taper pin on the rear crank. Drive the 1-inch taper pins from the rear cranks with the 3/32-inch drive pin punch and 4-ounce riveting hammer. Drive the pins toward the rear of the frame. Remove the handle bearings and rear lever stop. Take care not to lose the spacing washers. If the rear bearing plate is to be replaced, remove the plate mounting screws with the 4-inch E screwdriver and remove the plate. Substitute a new bearing plate and insert and securely tighten the mounting

screws. If any other part is to be replaced, make the necessary substitution of parts at this time. Insert the handle bearing at the right through the frame. Mount the rear lever stop, a washer, and the double-lever crank on the handle bearing. Insert the left-handle bearing through the frame and mount the washers and the single-lever crank in position. Rotate the right-handle bearing until the slot in the bearing is vertical. This will align the hole in the handle bearing shaft with the hole in the double-lever crank. Rotate the left-handle bearing so that the holes in the handle bearing and in the single-lever crank are in alignment. When the single-lever crank has two holes, rotate the left-handle bearing so that the hole in the rear crank nearer the frame is in alignment with the hole in the handle bearing. Insert and drive in the 1-inch taper pins in each bearing. If the rear lever stop was replaced, remove the spring from the stop and mount it on the new part. Reassemble the parts that were removed as covered in 3.43. Loop the closed end of the operating-lever spring under and around the rear crank and over the taper pin.

**3.45 Ribbon Rollers, Spool Lock Units, Rear Spool, Rear Spool Friction Spring, Ribbon Reverse Mechanism, Ribbon Feed Bar Unit, and Frame:** To replace any of these parts, remove the lever cranks and rear bearing plate as covered in 3.44 and proceed as follows. Remove the frame mounting screws with the 4-inch E screwdriver. Separate the two parts of the frame. If a ribbon roller, the spool lock unit, the rear spool, or rear spool friction spring is to be replaced, remove it from its bearing in the frame and substitute the new part. If the ribbon reverse mechanism is to be replaced, remove the taper pin from the ribbon reverse mechanism bearing stud with the No. 485A pliers and remove the washer. Remove the mechanism from the bearing stud and substitute the new part. Mount the washer over the stud and insert the taper pin through the stud. If the ribbon feed bar unit is to be replaced, remove the ribbon reverse mechanism as covered above and remove the ribbon feed bar spring. Remove the taper pin from the two mounting studs with the No. 485A pliers, remove the washers and the unit. Substitute the new part on the mounting studs, place the washers over the studs, and insert the taper pins. Re-mount the ribbon reverse mechanism as covered

above. Remount the ribbon feed bar spring. To replace the frame, remove all the parts as covered above and the reverse unit lock spring and mount them on a new frame. To reassemble the parts, proceed as follows. Make sure that the ribbon rollers, the spool lock unit, the rear spool, and the rear spool friction spring are mounted in their bearings. Place the sides of the frame together with the ends of the shafts of the parts in the bearings in both sides of the frame. Hold the sides in position and insert and securely tighten the two frame-mounting screws. Check that the shafts rotate freely. Remount the rear bearing plate, the lever cranks, and other parts as covered in 3.44.

#### Case and Associated Parts

**3.46 Mounting Bracket Assembly:** To replace the mounting bracket assembly, raise the keyshelf and, while holding the assembly to be replaced, remove the mounting screw with the 3-inch C screwdriver. Remove the assembly. Make sure that the insulating shield is in place and substitute the new bracket assembly in place. Insert and tighten the mounting screw securely.

**3.47 Insulating Shield:** To replace either the front or rear insulating shield, remove the mounting bracket assembly as covered in 3.46, and remove the shield. Substitute the new part and remount the bracket assembly securely in place.

**3.48 Case Contact Block and Associated Parts:** To replace any of these parts, replace the entire assembly as a unit as follows. Disconnect the source of power. Then loosen the spring contact screws with the 3-inch C screwdriver and remove the connecting wires from under the screwheads. Remove the mounting bracket assembly mounting screws as covered in 3.46 and remove the case. Make sure that the insulating shields are not damaged. Remove the case contact block mounting screws with the 3-inch C screwdriver. Remove the block from the case. Remove the mounting nuts from the block.

Mount the nuts in the new block. Substitute the new block and mount it securely in position with the mounting screws and nuts. Remount the case in the keyshelf, first making sure that the insulating shields are mounted as covered in 3.47. Insert first one and then the other, connecting the wires in place under the screwheads. After the connections have been satisfactorily made, reconnect the source of power and pull the excess wire down through the hole in the bottom of the case.

**3.49 Case:** To replace the case, proceed as covered in 3.48 to remove the case from the keyshelf and remove the case contact assembly from the case. Mount the parts in the new cases and substitute the new case in the keyshelf as covered in 3.48.

#### Dust Covers

**3.50 Dust Covers:** To replace a dust cover, remove the Calculagraph from the case as covered in 3.02. Remove the dust cover to be replaced and substitute the new part. Remount the Calculagraph in the case as covered in 3.02.

#### Rubber Stop and Front Stop Block Assembly

**3.51 Rubber Stop:** To replace a rubber stop, remove the old stop. Cover the surfaces of the slot in the frame and that portion of the new stop that fits into the slot with No. 30 Pliobond Adhesive applied with the flat end of a toothpick. Allow both parts to dry slightly and then press the stop into the slot in the frame. After the stop is securely cemented in place, remove the excess cement with a toothpick.

**3.52 Front Stop Block Assembly (KS-7769, List 11 through 16 Calculagraphs):** To replace the front stop block assembly, unscrew the two screws with the 3-inch C screwdriver and remove the old block. Substitute a new block and insert and securely tighten the mounting screws.

01 02 11

)

)

3  
4  
5

)

)

)

3  
4  
5

)

)