

NONZONE TEST TIMERS NO. 1C AND D-99325,  
COIN TEST TIMERS NO. 1D AND D-99326,  
AND ASSOCIATED NOS. 51B, 51D, 52B, D-156125, AND D-179539 DRIVES  
REQUIREMENTS AND ADJUSTING PROCEDURES

1. GENERAL

1.01 This section covers the nonzone test timers No. 1C and D-99325, the coin test timers No. 1D and D-99326, and the associated Nos. 51B, 51D, 52B, D-156125, and D-179539 drives.

1.02 This section is reissued to include the Nos. 51D, 52B, and D-179539 drives. Detailed reasons for reissue will be found at the end of the section.

1.03 Reference shall be made to Section 020-010-711, covering general requirements and definitions for additional information necessary for the proper application of the requirements listed herein.

\*1.04 Asterisk: Requirements are marked with an asterisk (\*) when to check for them would necessitate the dismantling or dismantling of apparatus, or would affect the adjustment involved or other adjustments. No check need be made for these requirements unless the apparatus or part is made accessible for other reasons or its performance indicates that such a check is advisable.

1.05 One discharge of WECO 57997 petrolatum for the purpose of this section is the amount of petrolatum discharged from the No. 353C grease gun when the piston is fully depressed once.

1.06 One discharge of KS-6438 oil for the purpose of this section is the amount of KS-6438 oil discharged from the No. 552A oil gun when the piston is fully depressed once.

1.07 One dip of KS-8496 No. 3 lubricating compound for the purpose of this section is the amount of lubricant retained on the KS-14164 brush after being dipped in the lubricant to a depth of approximately 3/8 inch and scraped once against the side of the container as the brush is removed. There shall not be sufficient lubricant adhering to the brush to form a drop on the end of the bristles.

1.08 Normal Position of Timer Gear and Cams: The timer gear and associated cams are in their normal position when the end of the gear stop is resting against the end of the gear stop pawl or spring and with the armature resting against the head of the adjusting screw.

1.09 The term contact spring when used in this section includes, unless otherwise specified, both contact bars welded to the end of

the spring. The front end of the spring may or may not be split. A pair of contacts as referred to in this section consists of a single contact bar of one contact spring and the corresponding contact bar on the opposing contact spring.

1.10 Armature travel is the gap between the stop plate on the armature and the nearest point on the pole piece when the armature is resting against the head of the adjusting screw.

1.11 Unless otherwise specified in the individual requirements, the driving shaft may be either rotating or stopped when checking that a requirement is met.

1.12 Before checking or readjusting to meet the requirements, the equipment should be taken out of service in accordance with the procedures outlined in the section covering methods of taking equipment out of service. When necessary to stop the motor of the driving shaft, make sure that the circuits associated with all timers operated by the driving shaft are made busy.

2. REQUIREMENTS

2.01 Cleaning

(a) Contacts shall be cleaned when necessary in accordance with the section covering cleaning of relay contacts. After cleaning any contact, a check shall be made to see that both contacts on the bifurcated spring involved close as specified in requirement 2.23(c).

(b) Other parts shall be cleaned when necessary in accordance with approved procedures.

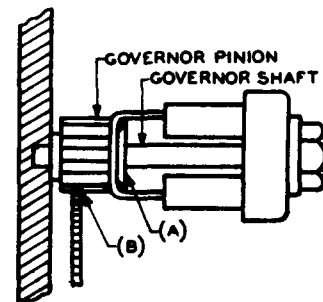

Fig. 1 - Lubricating Governor Pinion

SECTION 030-140-703

2.02 Lubrication

(a) The following parts shall be adequately lubricated with WECO 57997 petrolatum. When lubrication is necessary, the lubricant shall be applied with the No. 353C grease gun equipped with a No. 570A straight nozzle as follows:

- (1) Two discharges distributed evenly around the circumference of the driving shaft at each support bearing (one discharge on each side of the support) and two discharges at the left and right thrust bearings.
- (2) Fig. 2(A) - One discharge to the slot in the pinion.
- (3) Fig. 2(B) - One discharge to the groove in the pinion.
- (4) Fig. 2(C) - Two discharges distributed evenly around the circumference of the shaft at each end of the pinion.
- (5) Fig. 2(D) - Three discharges to the hole in the hub of the gear shaft.
- (6) Fig. 1(A) - One discharge at the right-hand end of the governor pinion.

(b) Fig. 5(A) - The friction washer shall be adequately lubricated with KS-6438 oil. When lubrication is necessary, one discharge

of the lubricant shall be applied with the No. 552A oil gun to each of the two holes in the damping disc.

(c) Fig. 5(H) - The surface of the timer gear where it is engaged by the pinion prior to meshing shall be adequately lubricated with KS-8496 lubricating compound. When lubrication is necessary, one dip shall be applied to the face of the timer gear at the point of pinion engagement.

(d) Where the motor is a recoilable type, lubricate it as specified in the section covering lubrication of Telechron motors.

(e) Recommended Lubrication Intervals: It is recommended that all parts except the driving shaft bearings, surface of the timer gear, and the motor be lubricated at intervals of 24 months, the driving shaft bearing and the surface of the timer gear be lubricated at intervals of 12 months, and the motor at intervals as specified in the section covering lubrication of Telechron motors. These intervals may be extended or reduced if periodic inspections have indicated that local conditions are such that requirements (a) to (d), inclusive, are met during the extended or reduced intervals.

2.03 Record of Lubrication: During the period of installation, a record shall be kept by date of the lubrication of the timers and

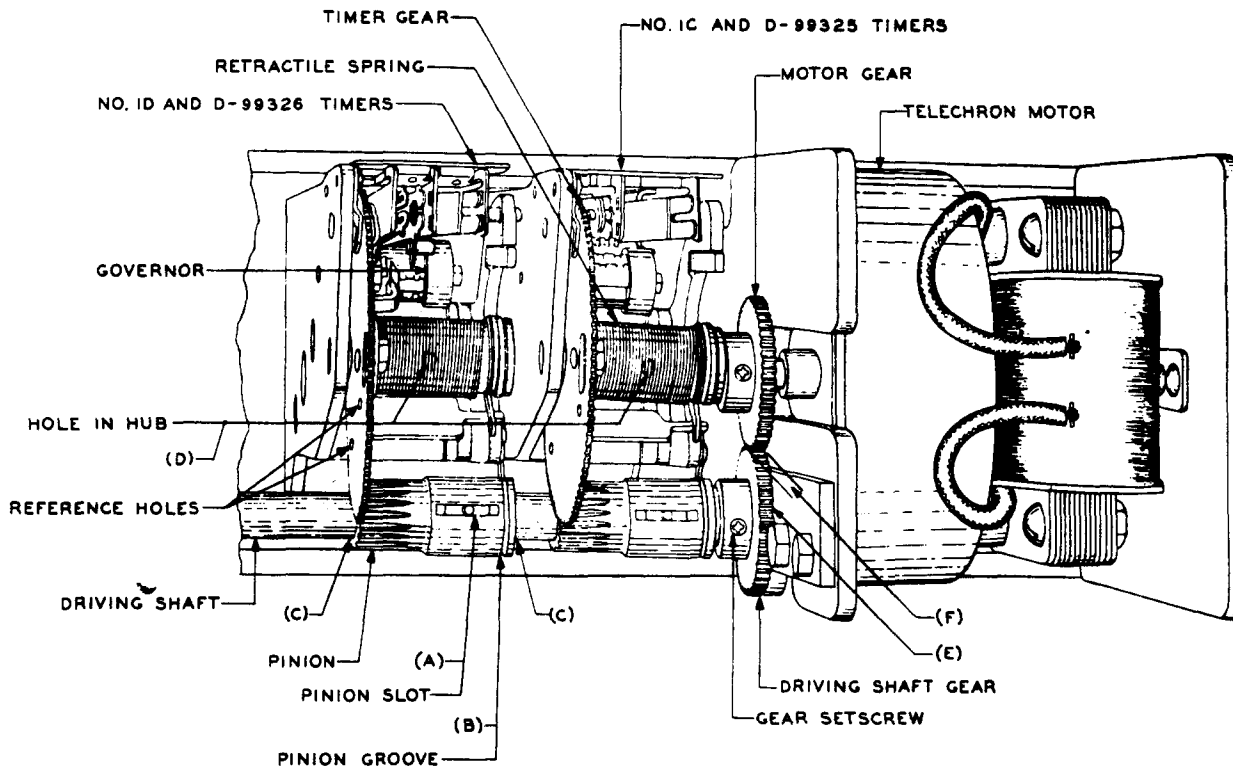

Fig. 2 - Timers and Associated Drive Assembly

associated drives and this record shall be turned over to the telephone company with the equipment. If no lubrication has been done, it shall be so stated.

2.04 End Play of Driving Shaft: Fig. 2(E) - With the driving shaft motor stopped the end play of the shaft shall be

Min Perceptible  
Max 0.010 inch

To check this requirement gauge the minimum by feel and the maximum by inserting the No. 74D gauge between the shoulder of the gear and the plate.

2.05 Engagement of Motor and Driving Shaft Gears: The following requirements shall be met with the driving shaft motor stopped.

(a) The backlash between the driving shaft gear and the motor gear shall be

Min 0.005 inch

Gauge by feel.

Check this requirement in four positions of the driving shaft gear approximately 90 degrees apart.

(b) Fig. 3(A) - The teeth of the motor and driving shaft gears shall engage vertically for

Min 1/2 their depth

Gauge by eye.

Check this requirement in four positions of the driving shaft gear approximately 90 degrees apart.

(c) Fig. 2(F) - The teeth of the motor and driving shaft gears shall engage for their full width, at one point in the position of the gears, when they are moved back and forth in opposite directions to the extreme limits of motor and driving shaft end play. In no case, however, shall the engagement be less than 1/2 the width of the gear.

Gauge by eye and feel.

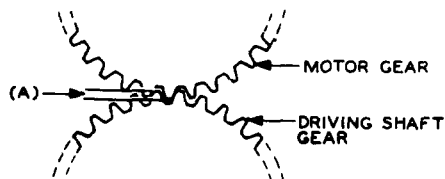

Fig. 3 - Engagement of Motor and Driving Shaft Gears

2.06 Mounting of Timers

(a) Timers shall be fastened securely to the mounting plate and shall be so mounted that the side of the mounting bracket is approximately perpendicular to the driving shaft.

Gauge by eye and feel.

(b) The locknut on the positioning screw at the rear of the timer shall be tight.

Gauge by feel.

(c) Fig. 4(A) - With the driving shaft motor stopped and with the timer electrically operated, the teeth of the timer gear shall engage with the pinion in all positions of the gear for

Min 2/3 their depth

but there shall be backlash.

Gauge by eye.

To check this requirement, rotate the gear manually so that one of the four reference holes in the gear is adjacent to the teeth in the pinion. Operate the timer electrically and check for engagement and backlash. Repeat this operation at the other three reference holes in the gear.

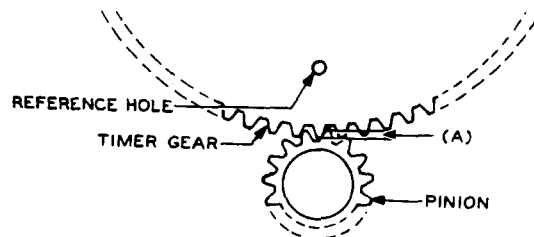

Fig. 4 - Engagement of Timer Gear and Pinion

2.07 Engagement of Shifting Spring Tang and Pinion - Fig. 5(B)

(a) The shifting spring tang shall not touch the bottom of the pinion groove in the associated pinion but shall engage the pinion groove for

Min 1/32 inch

Gauge by eye for one complete revolution of the pinion.

To check this requirement, press up on the bottom of the pinion and observe if there is a movement of the pinion before it touches the bottom of the shifting spring tang.

SECTION 030-140-703

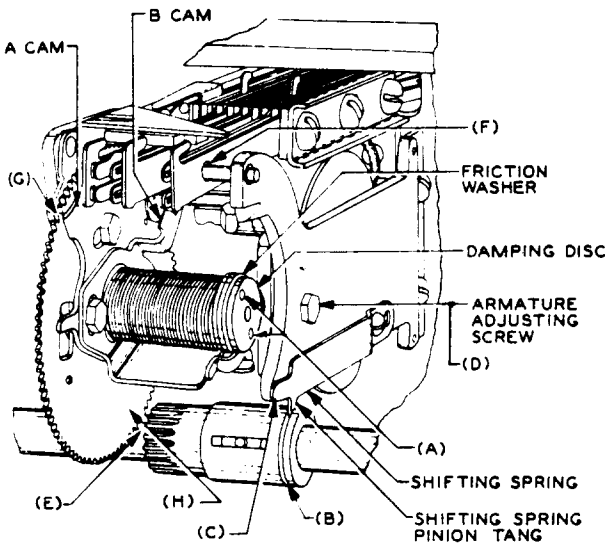

Fig. 5 - Engagement of Shifting Spring Tang and Pinion

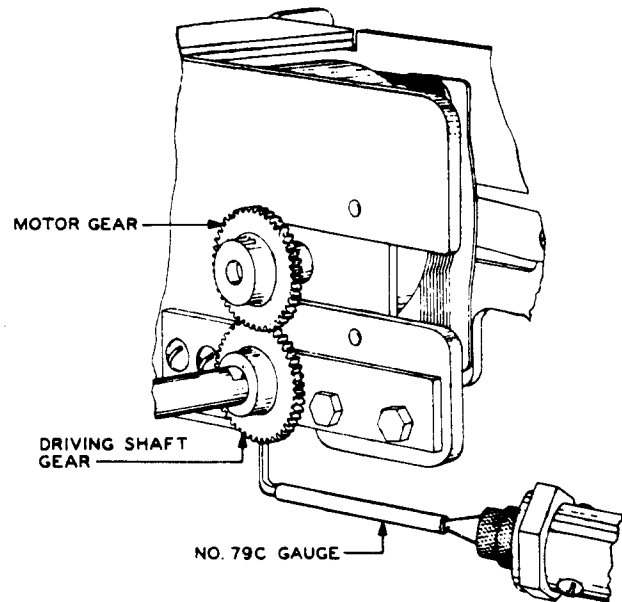

Fig. 6 - Method of Checking Freedom of Shaft Movement

(b) With the shifting spring tang touching one side of the pinion groove there shall be a clearance between the shifting spring tang and the other side of the pinion groove. Gauge by eye and feel.

\*2.08 Freedom of Shaft Movement: With the driving shaft motor stopped, with the motor gear disengaged, and with the shifting spring tangs of all timers on the plate engaged in the pinion groove, the shaft shall rotate freely. This requirement is met, if the shaft turns with the force specified below for the number of timers involved applied to a tooth of the driving shaft gear.

Nos. 51B, 51D, and D-156125 Drives

<u>Timers</u>	<u>Tension</u>
None	50 grams
1 to 10	75 grams
11 to 20	100 grams

No. 52B and D-179539 Drives

<u>Timer</u>	<u>Tension</u>
None	50 grams
1 to 7	75 grams
8 to 14	100 grams

Use the No. 79C gauge applied to the gear as shown in Fig. 6 and check at four points approximately 90 degrees apart.

2.09 Tripping Cam Clearance

(a) With the tripping cam in the position where it is just about to trip the retractile spring, the retractile spring shall not be tripped until the motion of the timer gear from the normal position has been

Min two teeth

Gauge by eye.

(b) Fig. 7(A) - With the timer gear restored to normal, immediately after the retractile spring has been tripped, and with the play in the tripping cam taken up to insure the maximum clearance between the trailing tang of the tripping cam and the tripping finger attached to the timer gear, the clearance between the trailing tang of the tripping cam and the tripping finger attached to the timer gear, shall be

Min 1/32 inch

Gauge by eye.

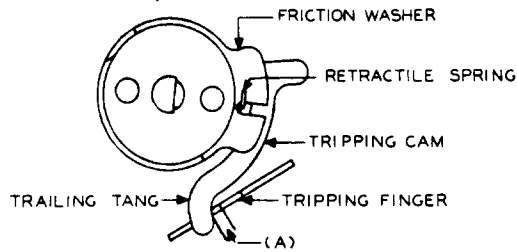

Fig. 7 - Tripping Cam Clearance

2.10 Freedom of Pinion Movement and Shifting Spring Tension: Fig. 5(C) - With the

driving shaft motor stopped and with the end play in the pinion taken up to the left, the shifting spring shall leave the armature and the pinion shall move with a force applied to the tip of the shifting spring of

Max 100 grams

and with the end play in the pinion taken up to the right, the shifting spring shall restore against its stop when this force is reduced to

Test - Min 15 grams  
Readjust - Min 20 grams

Use the No. 70J gauge.

When checking the tension of the shifting spring where the No. 70J gauge cannot be applied due to mounting conditions, the requirement is met if the tension, as determined by lifting the spring with a KS-6320 orange stick, is approximately the same as the tension of another shifting spring which meets this requirement when checked by the No. 70J gauge.

2.11 Armature Travel: The armature travel shall be

Min 0.053 inch  
 Max 0.060 inch

Use the No. 142A gauge.

\*2.12 Armature Adjusting Screw Clearance:

Fig. 5(D) - The armature adjusting screw shall not touch the sides of the hole in the armature during the operation of the armature.

Gauge by eye and feel.

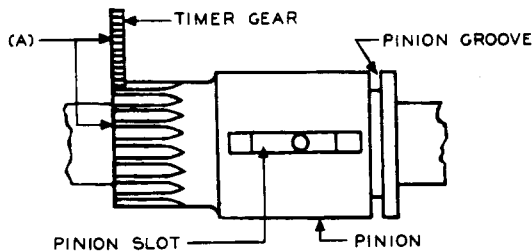

Fig. 8 - Engagement of Pinion With Associated Gear

2.13 Index Finger Position: Fig. 5(G) - The clearance between the index finger and the timer gear in all positions of the gear shall be

Min 0.005 inch

Gauge by eye.

2.14 Pinion Position

(a) Fig. 5(E) - With the timer unoperated and the end play in the pinion taken up to make the clearance between the gear and pinion as small as possible, the gear shall not touch the pinion at the positions of the four reference holes of the gear.

Gauge by eye.

To check this requirement, rotate the gear manually until one of the four reference holes in the gear is adjacent to the pinion and observe the clearance between the pinion and the gear. Repeat this operation at the other three reference holes in the gear.

(b) Fig. 8(A) - With the timer electrically operated and the end play in the pinion taken up to make the meshing as small as possible, the teeth of the gear shall mesh for at least their full width with the pinion at the positions of the four reference holes of the gear.

Gauge by eye.

To check this requirement, operate the timer electrically and note to what extent the pinion meshes with the gear, horizontally. Repeat this operation at the other three reference holes in the gear.

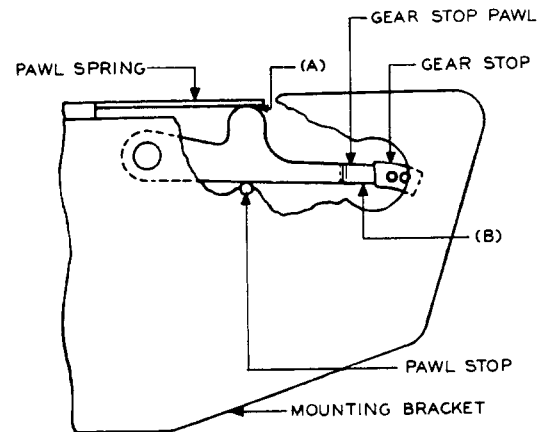

Fig. 9 - Gear Stop Pawl Position

2.15 Gear Stop Pawl Position (for timers equipped with a gear stop pawl)

(a) With the end play of the timer gear taken up toward the mounting bracket, the pawl shall drop freely off the gear stop and against the pawl stop when the timer gear is rotated one revolution.

Gauge by eye.

(b) With the end play of the timer gear taken up toward the mounting bracket, the pawl shall not bind against the gear during the rotation of the gear.

Gauge by eye.

This requirement is met, if the gear restores to normal under the conditions covered in requirements 2.29(a) and (b).

SECTION 030-140-703

(c) Fig. 9(A) - With the timer gear moved slightly from its normal position and with the pawl resting against the pawl stop, the pawl spring shall touch the pawl or if it does not touch the clearance between the pawl spring and the pawl, shall not exceed 1/64 inch.

Gauge by eye.

\*(d) Readjust Only: Fig. 9(B) - The tension of the pawl spring shall be

Max 5 grams

Use the No. 70H gauge.

To check this requirement, apply the No. 70H gauge at the end of the pawl.

2.16 Gear Stop Spring Position (for timers equipped with a gear stop spring)

(a) With the timer gear moved off-normal, the gear stop spring shall rest against the gear wheel with a slight pressure. This requirement is met, if the stop spring rests against the gear and the gear restores to normal under the conditions covered in requirement 2.29(a).

(b) Fig. 10(A) - There shall be a clearance between the gear stop spring and the mounting bracket as the gear stop passes under the free end of the gear stop spring.

Gauge by eye.

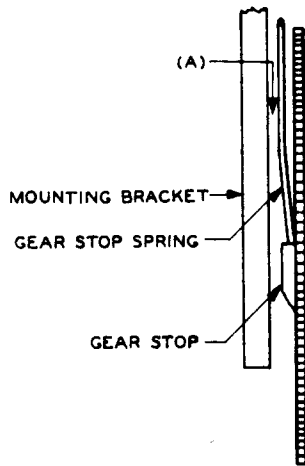

Fig. 10 - Gear Stop Spring Position

2.17 Engagement of Timer Gear and Governor

Pinion: Fig. 1(B) - The teeth of the governor pinion shall mesh with the teeth of the timer gear sufficiently to provide a good, free-running fit, with backlash, for one complete revolution of the timer gear.

Gauge by eye and feel.

To check this requirement, move the timer gear off-normal with the fingers. Rotate the gear backward and forward several times, a distance equal to about one gear tooth, and note by feel and observing the pinion whether there is play between the gear and pinion or whether they tend to bind. Repeat this operation at the positions of the four reference holes of the gear.

2.18 Contact Alignment

Γ (a) Fig. 11(A) - On all timers equipped with standard contacts, the contacts shall line up so that the width on the contact surface of each contact bar falls wholly within the length of its mating bar.

L Gauge by eye.

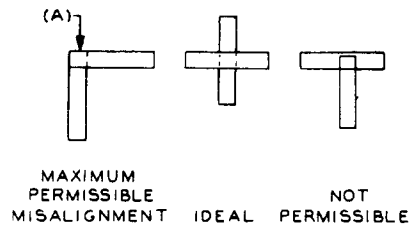
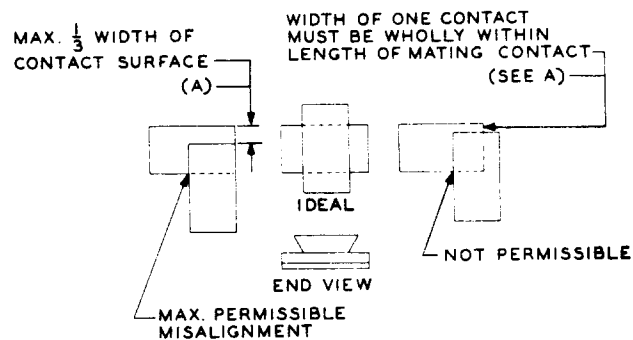

Fig. 11 - Alignment of Standard Contacts

Γ (b) Fig. 12(A) - On timers equipped with heavy contacts, the contact alignment shall be within the limits indicated in Fig. 12.

Gauge by eye.



L Fig. 12 - Alignment of Heavy Contacts

2.19 Spacer and Stud Clearance

(a) Fig. 18(A) - The spacers on the solid springs shall not rub against the bifurcated springs through which they pass.

Gauge by eye and feel.

(b) Fig. 5(F) - The hard-rubber studs on the armature or bifurcated springs shall not rub against the solid springs through which they pass.

Gauge by eye and feel.

## 2.20 Spring Tension

(a) "A" Cam Bifurcated Spring (No. 1C and D-99325 Timers): With the timer gear rotated so that the stud on the bifurcated contact spring does not rest on the cam, the tension of the bifurcated spring against the head of the associated spacer shall be

Min 4 grams  
Max 15 grams

Use the No. 70H gauge applied in front of the contacts.

(b) "A" Cam Springs (No. 1C and D-99325 Timers): With the timer gear rotated so that the stud on the bifurcated spring does not rest on the cam, the combined tension of the solid and bifurcated contact springs just as the tang of the spring leaves its stop shall be

Test - Min 35 grams  
Readjust - Min 40 grams

Use the No. 70D gauge applied in front of the contacts on the solid spring.

(c) "A" Cam Solid Spring (No. 1D and D-99326 Timers): With the timer gear normal, the tension of the solid contact spring against its stop shall be

Test - Min 25 grams  
Readjust - Min 30 grams

Use the No. 70H gauge applied in front of the contacts.

(d) "B" Cam Bifurcated Spring (No. 1D and D-99326 Timers): With the timer gear normal, the tension of the bifurcated contact spring against the head of the associated spacer shall be

Min 4 grams  
Max 15 grams

Use the No. 70H gauge applied in front of the contacts.

(e) "B" Cam Springs (No. 1D and D-99326 Timers): With the timer gear normal, the combined tension of the solid and bifurcated springs shall be

Test - Min 35 grams  
Readjust - Min 40 grams

Use the No. 70D gauge applied in front of the contacts of the solid spring.

(f) Armature Solid Spring: With the armature operated, the tension of the associated solid spring against the stop shall be

Test - Min 15 grams  
Readjust - Min 20 grams

Use the No. 70H gauge applied in front of the contacts.

\* (g) Armature Springs: With the shifting spring disengaged from the pinion, the combined tension of the armature contact springs against the associated stud shall be such that the armature may be moved from its adjusting screw with a force of

Min 45 grams

Use the No. 70D gauge applied in front of the stud.

2.21 Contact Pressure of "A" Cam Contacts (No. 1D and D-99326 Timers): With the timer gear rotated so that the "A" cam is not in contact with the stud on the associated bifurcated spring, the contact pressure as it leaves the solid spring shall be

Test - Min 20 grams, Max 35 grams  
Readjust - Min 25 grams, Max 35 grams

Use the No. 70D gauge applied in front of the contacts on the bifurcated spring.

## 2.22 Contact Separation

(a) "A" Cam Contacts (No. 1C and D-99325 Timers): Fig. 18(B) - With the timer gear normal, the contact separation shall be

Min 0.015 inch

Gauge by eye.

Use the No. 132D gauge as a reference.

(b) "A" Cam Contacts (No. 1D and D-99326 Timers): Fig. 18(E) - With the timer gear rotated so that the stud of the bifurcated spring rests on the flat of the "A" cam and with the play in the timer gear taken up to the left, the contact separation shall be

Min 0.020 inch  
Max 0.032 inch

Use the Nos. 132F and 132K gauges.

Check this requirement by placing the proper 132-type gauge in the contact gap as indicated in Fig. 13. If the minimum gauge passes between the contacts due to its weight alone, the minimum requirement is met. If the maximum gauge fails to pass between the contacts without moving the flexible contact spring, the maximum requirement is met.

SECTION 030-140-703

(c) "B" Cam Contacts (No. 1D and D-99326 Timers): Fig. 18(F) - With the timer gear normal, the contact separation of the "B" cam contacts shall be

Min 0.010 inch

Gauge by eye.

Use the No. 132B gauge as a reference.

(d) Armature Contacts: With the armature operated, the contact separation shall be

Min 0.010 inch

Gauge by eye.

Use the No. 132B gauge as a reference.

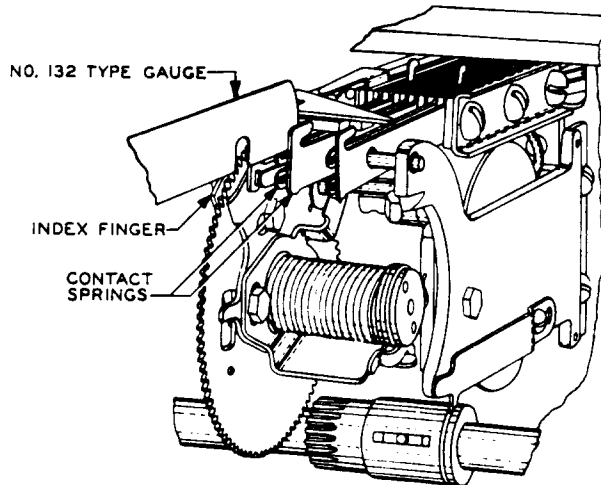

Fig. 13 - Method of Gauging Contact Separation

2.23 Spring Gauging

(a) Both contacts of the bifurcated contact springs shall make with their associated contacts in the fully operated or nonoperated position of the springs, whichever position represents the closed position for the contacts.

Gauge by eye and feel.

(b) "A" Cam Springs (No. 1C and D-99325 Timers): With the timer gear rotated so that the springs are in the fully operated position and with a gauge of the value indicated below inserted between the tang of the solid spring and its stop, the contacts shall meet the following conditions.

Use the Nos. 74D and 132D gauges.

	Contacts Shall Not Make (Inches)	At Least One Pair of Contacts Shall Make (Inches)
Test	0.015	0.007
Readjust	0.015	0.010

Test  
Readjust

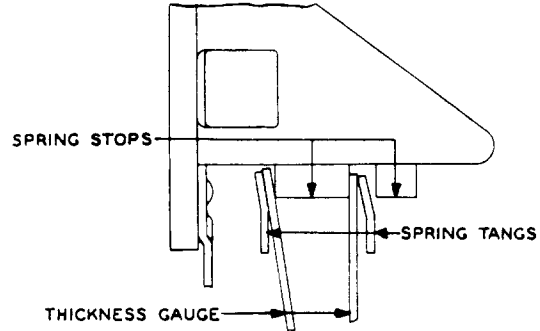

Fig. 14 - Method of Gauging Contact Springs

To check this requirement, insert the gauge having the specified thickness between the spring tang and its stop and parallel to either the stop or spring tang whichever will insure the minimum separation between the tang and the stop, as shown in Fig. 14. The contacts shall be checked with the end play of the timer gear taken up toward the mounting bracket. Check whether a contact makes, by applying the KS-6320 orange stick to the tip of the bifurcated spring and attempt to move the contact toward its associated spring. A movement of the bifurcated spring indicates that the contact is not closed.

(c) Readjust Only: After a particular contact is cleaned, build-up is removed or adjustments are made on a contact spring, both contacts on the bifurcated spring shall make approximately simultaneously with their associated contacts if it is a make contact or shall break approximately simultaneously with their associated contacts if it is a break contact. Operate the timer manually and gauge by eye.

(d) B Cam Springs (No. 1D and D-99326 Timers): With the timer gear rotated so that the springs are in the fully operated position and with a gauge of the value indicated below inserted between the tang of the solid spring and its stop, the contacts shall meet the following conditions.

Use the Nos. 74D and 132F gauges.

	Contacts Shall Not Make (Inches)	At Least One Pair of Contacts Shall Make (Inches)
Test	0.020	0.010
Readjust	0.020	0.013

Test  
Readjust

Check as covered in (b).



2.24 Contact Follow: Fig. 18(H) - With the timer unoperated, the gap between the tang of the armature solid contact spring and its associated stop shall be

Test - Min 0.010 inch  
Readjust - Min 0.015 inch

Use the 132-type gauges.

2.25 Bifurcated Spring Position

(a) No. 1C and D-99325 Timers

(1) "A" Cam Bifurcated Spring: Fig. 15(A) - With the timer gear rotated so that the stud on the bifurcated spring rests on the flat of the cam, the top surface of the stud shall be 0.015 inch ( $\pm 0.015$  inch) below the top edge of the cam.

Gauge by eye.

(The thickness of the timer gear is 0.030 inch.)

(2) With the timer gear rotated so that the stud does not rest on the "A" cam, there shall be a clearance between the stud and the gear of

Min 0.015 inch

Gauge by eye.

(1/2 the thickness of the timer gear.)

(b) No. 1D and D-99326 Timers

(1) "A" Cam Bifurcated Spring: Fig. 15(A) - With the timer gear rotated so that the stud on the bifurcated spring rests on the flat of the cam, the top surface of the stud shall be 0.015 inch ( $\pm 0.015$  inch) below the top edge of the cam.

Gauge by eye.

(The thickness of the timer gear is 0.030 inch.)

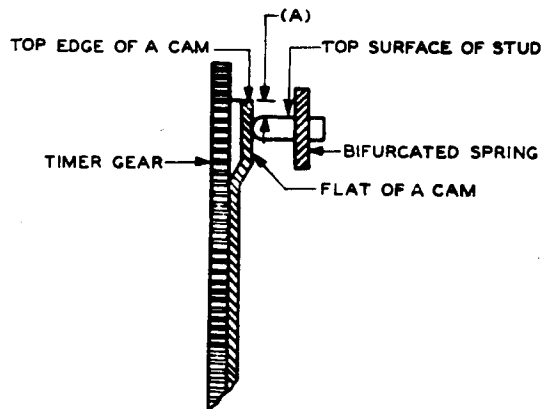

Fig. 15 - Bifurcated Spring Position

(2) "B" Cam Bifurcated Spring: With the timer gear rotated so that the "B" cam contacts are operated, the top surface of the stud shall be flush ( $\pm 0.015$  inch) with the top of the cam.

Gauge by eye.

2.26 "A" Cam Position

(a) No. 1C and D-99325 Timers: Fig. 16(A) and (B) - With the end play of the timer gear taken up to the left, the position of the "A" cam shall be such that the "A" cam contacts close after the gear has rotated one tooth movement from the normal position and before the gear has rotated 1-1/3 tooth movement from the normal position.

Gauge by eye.

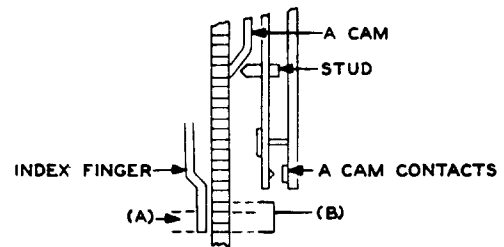

Fig. 16 - Method of Gauging "A" Cam Position

Note: A tooth movement is the movement of the timer gear equal to the distance between any point on a gear tooth and the corresponding point on the next tooth. To check the "A" cam position, note the position of the gear teeth with respect to the index finger. Rotate the gear manually from the normal position a movement of one gear tooth and check that the "A" cam contacts do not close. Rotate the gear an additional movement of 1/3 gear tooth and check that the "A" cam contacts are closed with at least one pair of contacts.

(b) No. 1D and D-99326 Timers: With the timer gear normal and the play in the gear taken up to the left, the position of the "A" cam shall be such that the associated contact gap is

Min 0.008 inch  
 Max 0.015 inch

Use the 132-type gauges.

2.27 "B" Cam Position (No. 1D and D-99326 Timers): The position of the "B" cam shall be such that the timing interval measured between the closure of the "A" cam contacts and the "B" cam contacts, covered by requirement 2.33(b)(3), is met.

SECTION 030-140-703

2.28 Timer Gear Retractable Spring Clearance:

With the coil of the retractile spring nearest the timer gears pushed as near the gear as possible, the clearance between the tip of the spring which projects through the gear and the mounting bracket shall be

Min 0.010 inch

Gauge by eye.

2.29 Timer Gear Retractable Spring Tension

(a) With the timer gear rotated so that the following end of the "A" cam is 1/8 inch ahead of the stud on the bifurcated spring and with a force of 50 grams applied to a tooth in a direction to cause the timer gear to rotate away from the normal position, the gear shall move away from the normal position and shall restore to normal when this pressure is reduced to

Test - 5 grams  
Readjust - 10 grams

Use the No. 79C gauge.

↗ To check this requirement, proceed as follows. Rotate the gear one quarter of a revolution to operate the tripping mechanism, thus insuring that the spring tension is at a minimum. Allow the gear to restore against its stop. Then apply the gauge to the bottom of the gear as indicated in Fig. 17. Hold the gauge horizontally and apply pressure gradually toward the rear of the timer  
↘ until the gear moves farther away from its

↗ normal position. Continue exerting pressure until the gear has moved from four to six teeth away from the normal position. Note that the pressure required to move the gear is not in excess of the specified 50 grams. Gradually reduce the pressure until the gear restores to its normal position. Note that the gauge reading does not go below the value specified until the gear has restored fully against its stop.  
↘

(b) Timers Equipped With a Stop Pawl:

With the timer gear turned so that the pawl is resting on the top of the pawl stop and with the front end of the pawl approximately in the center of the stop, the gear shall restore to normal against a pressure of 5 grams.

Use the No. 79C gauge.

↗ To check this requirement, proceed as follows. Rotate the gear one quarter of a revolution to operate the tripping mechanism, thus insuring that the spring tension is at a minimum. Allow the gear to restore against its stop then manually rotate the gear to the point where the front end of the pawl rests on the top of the pawl stop at approximately its center. Hold the gear in this position and apply the gauge to the gear as shown in Fig. 17, applying sufficient pressure to prevent the gear from restoring to normal. Gradually reduce the pressure until the gear starts to move toward the normal position. Check that the gauge reading, as the gear starts to move,  
↘ is not less than the specified value.

2.30 Straightness of Springs: Fig. 18(C) -

All springs shall be free of sharp bends or kinks due to adjustment, but a gradual bow in the springs is permissible.

Gauge by eye.

2.31 Separation Between Springs: Fig. 18(D) -

The clearance between adjacent springs, whether in their operated or unoperated position, shall be

Min 0.015 inch

Gauge by eye.

2.32 Electrical Requirements

(a) Operate: When the timer is assembled on a drive with the driving shaft motor stopped and the gear is in a position to prevent the pinion from meshing, the magnet shall operate the armature so that the stop plate on the armature touches the pole piece on the operate current specified on the circuit requirement table.

(b) Release: With the motor operating the driving shaft, the pinion shall disengage promptly from the timer gear and the gear restore to normal when the timer is

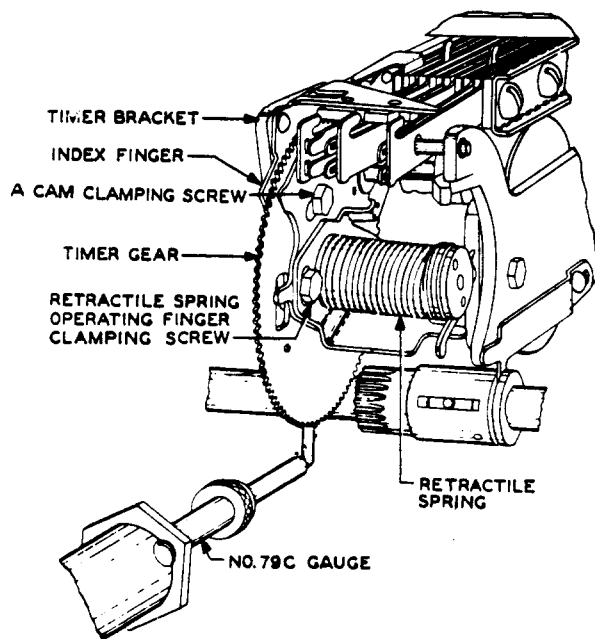

Fig. 17 - Method of Checking Retractable Spring Tension

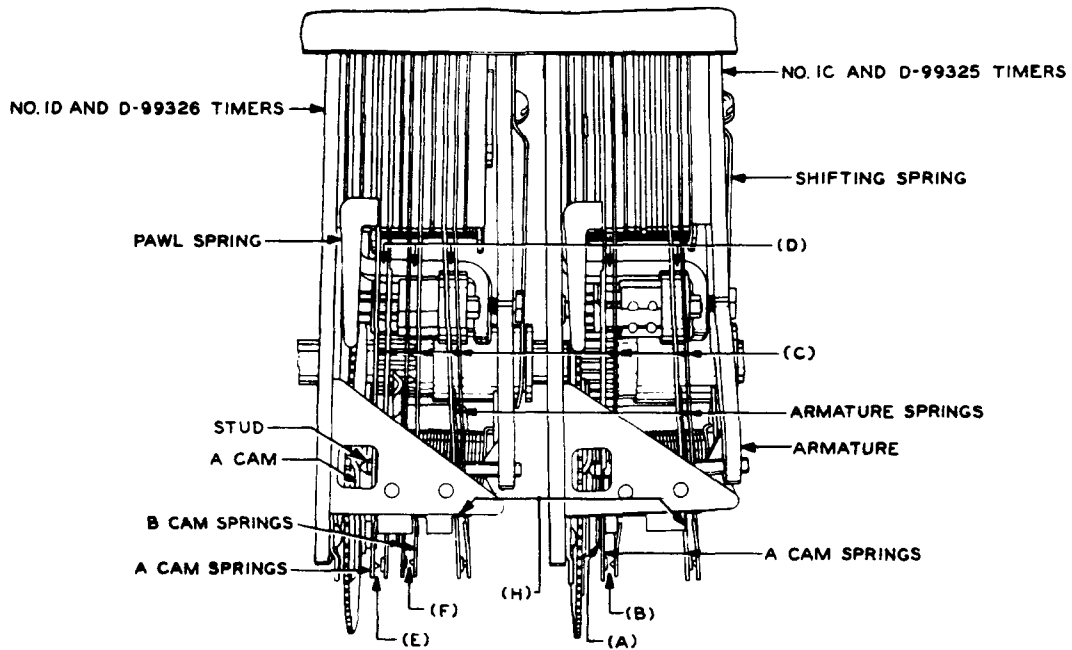

Fig. 18 - Timers - Top View

released. This requirement shall be met when the loop in the end of the gear retractile spring is just at the point of slipping over its stop and with a force of 15 grams applied just in front of the armature stud in a direction tending to operate the armature.

Use the No. 70H gauge.

To check this requirement, rotate the timer gear until the tripping cam begins to lift the loop in the end of the gear retractile spring. Operate the timer electrically. When the gear has been rotated approximately one-half tooth further, but before the spring has slipped over its stop and with the No. 70H gauge applying the specified tension to the armature, release the timer.

(2) Time of Closure of "A" Cam Contacts: Fig. 18(B) - The time of closure of the "A" cam contacts shall be

Drive	Time	
	Min	Max
51B	21 secs	25 secs
51D	17 secs	20 secs
52B	21 secs	25 secs
D-156125	21 secs	25 secs
D-179539	17 secs	20 secs

Use the KS-3008 stop watch. For checking, see requirements 2.33(c)(1) and (3).

2.33 Timing Requirements

(a) No. 1C and D-99325 Timers

(1) Time Between Closure and Reclosure of "A" Cam Contacts: Fig. 18(B) - The timing interval, measured from the closure of the "A" cam contacts, until the reclosure of these contacts shall be

Drive	Time	
	Min	Max
51B	5 mins 0 secs	5 mins 2 secs
51D	4 mins 0 secs	4 mins 2 secs
52B	5 mins 0 secs	5 mins 2 secs
D-156125	5 mins 0 secs	5 mins 2 secs
D-179539	4 mins 0 secs	4 mins 2 secs

Use the KS-3008 stop watch. For checking, see requirements 2.33(c)(1) and (2).

(b) No. 1D and D-99326 Timers

(1) Time Between Closure and Reclosure of "A" Cam Contacts: Fig. 18(E) - The timing intervals, measured from the closure of the "A" cam contacts, until the reclosure of these contacts shall be

Drive	Time	
	Min	Max
51B	5 mins 0 secs	5 mins 2 secs
51D	4 mins 0 secs	4 mins 2 secs
52B	5 mins 0 secs	5 mins 2 secs
D-156125	5 mins 0 secs	5 mins 2 secs
D-179539	4 mins 0 secs	4 mins 2 secs

Use the KS-3008 stop watch. For checking, see requirements 2.33(c)(1) and (2).

(2) Time of Closure of "A" Cam Contacts: Fig. 18(E) - The time of closure of the "A" cam contacts shall be

SECTION 030-140-703

Drive	Time	
	Min	Max
51B	4 mins 10 secs	4 mins 24 secs
51D	3 mins 20 secs	3 mins 31 secs
52B	4 mins 10 secs	4 mins 24 secs
D-156125	4 mins 10 secs	4 mins 24 secs
D-179539	3 mins 20 secs	3 mins 31 secs

Use the KS-3008 stop watch. For checking, see requirements 2.33(c)(1) and (4).

(3) Time Between Closure of "A" and "B" Cam Contacts: Fig. 18(E) and (F) - The timing interval, measured between the closure of the "A" cam contacts and the closure of the "B" cam contacts shall be

Drive	Time	
	Min	Max
51B	27 secs	38 secs
51D	21 secs	30 secs
52B	27 secs	38 secs
D-156125	27 secs	38 secs
D-179539	21 secs	30 secs

Use the KS-3008 stop watch. For checking, see requirements 2.33(c)(1) and (4).

(c) Checking Timing Requirements

(1) Preparation: Plug one end of each of two 1W13B cords, by means of the No. 360A tool, to the terminals of the bottom cap of the flashlights. Use the flashlights as specified below in making the tests. Closure of contacts will be indicated by lighting the associated flashlight and opening of contacts by extinguishing the flashlight. When checking the No. 1C or D-99325 timer, unsolder and remove the wire from 6T terminal of the MR2 relay on the same frame. When checking the No. 1D or D-99326 timer, insulate the 3T contact of the PU2 relay on the same frame.

(2) Time Between Closure and Reclosure of "A" Cam Contacts: Connect a flashlight to the proper spring terminals at the rear of the timer as indicated in Fig. 19 for the 1C timer or Fig. 20 for the 1D timer. Operate the timer magnet by connecting ground to the right winding terminal at the top of the timer. Begin timing with the KS-3008 stop watch when the "A" cam contacts first close, as noted by the lighting of the flashlight. During a revolution of the timer gear, timed from the point of contact closure, the contacts will open and again close at which closure cease timing.

(3) Time of Closure of "A" Cam Contacts: With a flashlight connected across the "A" cam contacts as in (2), operate the timer magnet by connecting ground to the right winding terminal at the top of the timer. Begin timing with the KS-3008 stop watch when the "A" cam contacts first close, as noted by the lighting of the

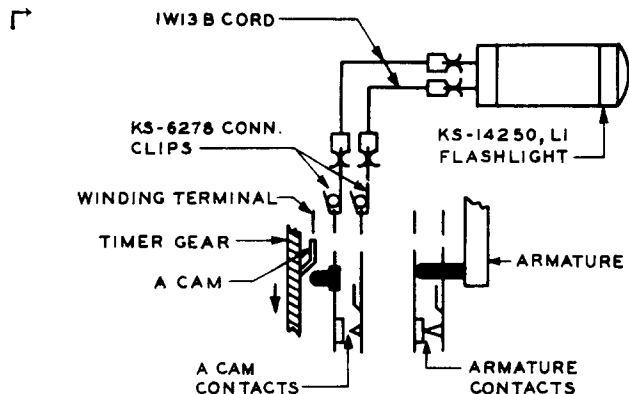

Fig. 19 - Connections for Checking "A" Cam Contact Closure

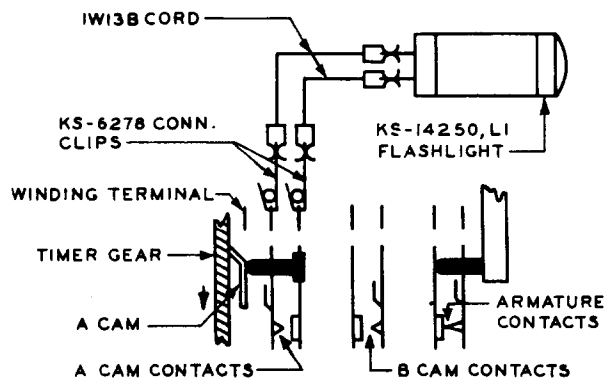

Fig. 20 - Connections for Checking "A" Cam Contact Closure

flashlight. Cease timing when the contacts open.

(4) No. 1D and D-99326 Timers - Time Between Closure of "A" and "B" Cam Contacts: Connect flashlights to the proper spring terminals at the rear of the timer as shown in Fig. 21. Operate the timer

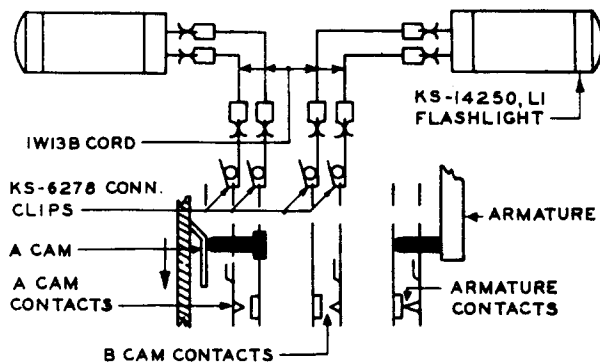

Fig. 21 - Connections for Checking "A" and "B" Cam Closures

magnet by connecting ground to the right winding terminal at the top of the timer. Begin timing with the KS-3008 stop watch when the "A" cam contacts first close, as noted by the lighting of the flashlight connected to these contacts. Cease timing when the "B" cam contacts close, as noted by the lighting of the flashlight connected to the contacts.

3. ADJUSTING PROCEDURES

3.001 List of Tools, Gauges, Materials, and Test Apparatus

<u>Code or Spec No.</u>	<u>Description</u>
<u>Tools</u>	
46	3/8-inch Hex. Single-end Socket Wrench
353C	Grease Gun (part of No. 1003A Tool Kit) (must be equipped with a No. 570A straight nozzle)
417A	1/4- and 3/8-inch Hex. Open Double-end Flat Wrench
485A	Smooth-jaw Pliers
505A	Spring Adjuster (for 0.013-inch springs)
506A	Spring Adjuster (for 0.023-inch springs)
507A	Spring Adjuster (for 0.030-inch springs)
510C (or replaced 510B)	Test Lamp (must be equipped with a No. 561A straight tip and a W2CB (24V) or a W2BL (48V) cord)
551A	Combination Wrench
552A	Oil Gun
563A	90-degree Offset Screwdriver
564A	45-degree Offset Screwdriver
KS-6320	Orange Stick
KS-6854	Screwdriver
KS-14164	No. 4 Artist's Show Card Brush
KS-14220	Wrench consisting of
List 1	Sliding T-handle
List 7	6-inch Extension
List 14	7/16-inch Socket
KS-14250, L1 (or replaced flashlight equipped with KS-7742 bottom cap) (2 reqd)	Flashlight

<u>Code or Spec No.</u>	<u>Description</u>
R-2653	No. 5 Bristo Setscrew Wrench ←
-	4-inch Regular Screwdriver
-	5-inch Regular Screwdriver
-	6-inch Cabinet Screwdriver
-	5-inch Diagonal Pliers

<u>Gauges</u>	
70D	50-0-50 Gram Gauge
70H	0-30 Gram Gauge
70J	0-150 Gram Gauge ←
74D	Thickness Gauge Nest
79C	0-200 Gram Push-pull Tension Gauge
131A	Thickness Gauge Nest (consists of a nest of 132-type gauges)
142A	0.053- and 0.060-inch Thickness Gauge
KS-3008 (or equivalent)	Stop Watch ←

<u>Material</u>	
KS-6438	Alaska Cylinder Oil
KS-7860	Petroleum Spirits
KS-8496	Lubricating Compound No. 3 ←
KS-14666 (or replaced D-98063)	Cloth
WECO 57997	Petrolatum (unmedicated white vaseline may be used)
-	Hardwood Toothpick, flat on one end, pointed on the other

<u>Test Apparatus</u>	
35 Type	Test Set
LW13B (4 reqd)	Cord (each equipped with a KS-6278 connecting clip in one end) ←

3.002 While readjusting to meet some of the requirements specified herein, as for example requirement 2.04, it will be necessary to open the motor circuit by removing the fuse. Checking and adjusting will also be facilitated if the setscrews in the motor gear are loosened to permit the driving shaft to be turned manually. After tests, tighten the setscrews and check that requirement 2.05(c) is met.

3.003 Due to mounting conditions, it may not be possible to make some of the adjustments unless the drive mounting is removed

## SECTION 030-140-703

from the frame or the timer is removed from the mounting plate. To remove the drive mounting plate from the frame, remove the locknuts (if provided) from the screws which attach the mounting plate to the frame using the KS-14220 wrench. Remove the mounting screws using the 5-inch regular screwdriver. This will permit the mounting plate to be moved forward far enough to give access to some of the parts for adjusting. Take care in moving the plate forward not to put any strain on the wires connecting to the timer terminals. To remove a timer from the mounting plate, first unsolder the leads from the winding terminals. Remove the positioning screw locknut with the No. 46 wrench and the positioning screw with the 6-inch cabinet screwdriver. Remove the two mounting screws with the 4-inch regular screwdriver, which will free the timer. Whenever the timer is removed for any reason, inspect for all requirements and make all adjustments that appear necessary at this time. After the timer has been properly tested and adjusted, remount it, making sure requirements 2.06, 2.07, 2.08, 2.10, 2.14, and 2.32(b) are met and resolder the wires that were removed.

### 3.01 Cleaning (Rq 2.01)

- (1) Clean the contacts in accordance with the section covering cleaning of relay contacts. Clean other parts in accordance with approved procedures.

### 3.02 Lubrication (Rq 2.02)

- (1) After lubricating any part of the timer or driving shaft, wipe off excess lubricant with the KS-14166 cloth.

- (2) Driving Shaft: To lubricate the shaft at the left and right thrust bearings, remove the bearing mounting screws at the left thrust bearing with the No. 417A wrench. Remove the end plate and move the driving shaft to the left sufficiently so that the No. 570A nozzle of the No. 353C grease gun will fit between the shaft gear and the right thrust bearing. Rotate the shaft until the flat on the shaft at the right thrust bearing is accessible and lubricate the shaft at that point. Lubricate the shaft at the left thrust bearing. Reposition the shaft so that the gears mesh. Remount the end plate and hold the end plate and left thrust bearing as tightly as possible against the locating plate and tighten the bearing mounting screws securely. Check that requirement 2.08 is met. Lubricate the shaft at each support bearing with the No. 570A nozzle of the No. 353C grease gun held to the shaft on each side of the bearing.

- (3) Pinion: Drive the shaft around until the slot in the pinion is accessible. Apply the lubricant to the groove with the No. 570A nozzle of the No. 353C grease gun held approximately perpendicular to the pinion. To lubricate the shaft at the right end of the pinion, first move the pinion to the left so that the pinion will engage with

the gear. To lubricate the shaft at the left end of the pinion, first move the pinion to the right as far as possible.

- (4) Shaft of Timer Gear: To lubricate the shaft of the timer gear, separate the turns of the retractile spring near the middle of the spring with a toothpick in order to insert the No. 570A nozzle of the No. 353C grease gun.

- (5) Governor Shaft: To lubricate the governor shaft, use the No. 353C grease gun. Rotate the associated large gear sufficiently to permit the No. 570A nozzle entering between the governor arms. Hold the end of the nozzle against the shaft as close to the right end of the governor gear as possible and apply the lubricant.

- (6) Friction Washer: To lubricate the friction washer, insert the curved end of the nozzle of the No. 552A oil gun in the hole in the damping disc and depress the plunger once. Repeat this operation in the other hole in the damping disc. Rotate the gear three or four revolutions, manually, to work in the oil. Wipe off surplus oil with the KS-14666 cloth, using a toothpick or the KS-6320 orange stick to insert the cloth between the frame of the adjacent timer and damping disc.

- (7) Point of Engagement of Timer Gear and Pinion: Rotate the timer gear manually so that the point of pinion engagement is at the front. The reference hole opposite the point of pinion engagement should be used as a guide to determine how far the gear should be turned. Remove any old lubricant from the gear surface with the KS-14666 cloth. Using the KS-14166 brush apply the lubricant to the face of the gear at the point of pinion engagement. Allow the gear to restore slowly to normal to prevent the lubricant reaching other surfaces where its presence might be objectionable.

- (8) Motor: Where the motor is a nonrecoilable type and it appears that lubrication is necessary, remove the motor as follows and substitute a new motor. On recoilable type, remove the motor. To do this unsolder the leads to the motor field coil terminals at the front of the motor. Loosen the locknut at the rear of the motor with the No. 417A wrench. Remove the two motor mounting screws with the Nos. 563A and 564A offset screwdrivers. Lift the motor so that the teeth of the motor gear do not engage the teeth of the driving shaft gear and draw the motor forward from the drive. Lubricate the motor in accordance with the procedures covered in the section covering lubrication of Telechron motors. Remount the motor by placing the slot in the motor plate over the mounting screw at the rear of the plate and sliding the motor toward the rear. Take care that the spacer is properly located between the motor and the mounting plate. Insert the

two motor mounting screws loosely and position the motor so that there is the proper amount of backlash between the motor and driving shaft gears. Tighten the mounting screws securely and tighten the locknut on the motor mounting screw at the rear of the motor. Reconnect the leads to the field coil terminals.

3.03 Record of Lubrication (Rq 2.03)  
(No Procedure.)

3.04 End Play of Driving Shaft (Rq 2.04)

(1) To adjust the end play of the driving shaft, loosen the setscrew in the driving shaft gear with the R-2653 Bristo setscrew wrench and move the gear to the right or left, as required. Insert the 0.004-inch blade of the No. 74D gauge between the gear and end plate to insure a clearance. Be sure in inserting the gauge that the end of the gauge rests against the surface of the driving shaft. Position the gear so that the setscrew is above the flat section of the shaft. With the end play of the shaft taken up to the left and the gear held firmly against the gauge tighten the gear setscrew securely. Remove the gauge. Check the horizontal position of the gears and, if necessary, shift the motor gear as outlined in 3.05(2).

3.05 Engagement of Motor and Driving Shaft Gears (Rq 2.05)

(1) To adjust the depth of engagement of the motor and driving shaft gears, loosen the screws and nut which hold the motor with the Nos. 563A and 564A offset screwdrivers and the No. 417A wrench. Position the motor so that the gears mesh properly and tighten the screws and nut securely.

(2) To adjust the alignment of the faces of the teeth of the motor and driving shaft gears, loosen the motor gear setscrews with the R-2653 Bristo setscrew wrench and move the gear to the right or left as required. Tighten the setscrews securely.

3.06 Mounting of Timers (Rq 2.06)

3.07 Engagement of Shifting Spring Tang and Pinion (Rq 2.07)

(1) To tighten loose mounting screws use the 4-inch regular screwdriver. To adjust the positioning screw use the 6-inch cabinet screwdriver. To tighten the positioning screw locknut use the No. 46 wrench.

(2) To adjust the engagement of the timer gear and shifting spring with the pinion, first loosen the positioning screw locknut at the rear of the frame with the No. 46 wrench. Turn the positioning screw with the 6-inch cabinet screwdriver until the shifting spring and timer gear are properly positioned with respect to the associated pinion. If the shifting spring and gear cannot be

adjusted simultaneously with respect to the pinion, loosen the timer mounting screws with the 4-inch regular screwdriver and turn the timer slightly to the left or right, as required, to give satisfactory adjustment but not enough to prevent the mounting bracket being approximately perpendicular to the drive shaft. If the gear and shifting spring still do not mesh properly with the pinion, remove the timer and loosen the shifting spring mounting-screw with the KS-6854 screwdriver and position the shifting spring up or down, as required, to insure its satisfactory engagement with the pinion. Tighten the shifting spring mounting screw securely and remount the timer.

(3) If there is no clearance between the shifting spring pinion tang and the sides of the pinion slot, it may be due to a bent tang or accumulation of dirt in the slot. Use a toothpick to clean out any dirt in the pinion groove. To adjust a bent tang, disengage the tang of the shifting spring from the pinion slot by loosening the positioning screw locknut with the No. 46 wrench and turning the timer positioning screw with the 6-inch cabinet screwdriver. Straighten the tang with the No. 485A pliers. Readjust the positioning screw until requirements 2.06, 2.07, 2.08, 2.10, 2.14, and 2.32(b) are met.

3.08 Freedom of Shaft Movement (Rq 2.08)

(1) Before adjusting a shaft which is tight in its bearings, first disengage the motor gear as covered in 3.002.

(2) To correct a tight shaft, first check that the shifting spring tangs are properly located as covered in requirement 2.07 and determine if any shifting spring tang binds at the pinion. If necessary, adjust the position of the shifting springs as outlined in 3.07.

(3) If the shaft still binds, lubricate in accordance with requirement 2.02.

(4) If after lubricating, the shaft does not turn freely, loosen the bearing mounting screws of the two middle support bearings with the No. 417A wrench and permit the shaft to assume a free position at the bearings. Tighten the bearing mounting screws securely. If the shaft moves freely, check requirements 2.06, 2.07, and 2.32(b) and insure that the timer gears and shifting springs engage properly with the pinions.

(5) If the shaft still binds, remove the shaft as outlined in (6) and wipe the shaft off with the KS-14166 cloth. Check for burrs at the bearing positions and for a bent shaft. If the shaft is bent or if the bind is not removed after cleaning the shaft and removing all burrs, replace the shaft with a new one.

## SECTION 030-140-703

(6) To remove the driving shaft, remove the bearing bracket mounting screws, except for the bracket adjacent the driving shaft gear, with the No. 417A wrench. After cleaning, position the driving shaft and bearing, holding the bearings as tightly as possible against the locating plate. Tighten the bracket mounting screws securely. Lubricate the shaft as covered in 3.02 and make sure that requirements 2.06, 2.07, 2.08, 2.10, and 2.32(b) are met.

(7) After adjusting or replacing the driving shaft, check the engagement of the motor and driving shaft gears and, if necessary, adjust as outlined in 3.05.

### 3.09 Tripping Cam Clearance (Rq 2.09)

(1) If the retractile spring is tripped too soon or there is insufficient clearance between the tripping cam and tripping finger, report the trouble to the supervisor.

### 3.10 Freedom of Pinion Movement and Shifting Spring Tension (Rq 2.10)

(1) To adjust for pinion movement, first disengage the associated timer gear and shifting spring from the pinion by loosening the timer positioning screw locknut with the No. 46 wrench and turning the positioning screw with the 6-inch cabinet screwdriver. With the timer disengaged and using the No. 70H gauge, check to see that the pinion will move freely with a force of 25 grams applied to either end of the pinion. If the pinion does not move freely, lubricate the shaft and pinion as outlined in 3.02.

(2) With the timer disengaged, check the tension of the shifting spring. The tension of the shifting spring against the armature should be between 40 and 80 grams. If the tension is not satisfactory, remove the timer and adjust the shifting spring with the No. 507A spring adjuster, applying the spring adjuster near the crook in the spring. If sufficient tension cannot be obtained in this manner, remove the shifting spring mounting screw with the KS-6854 screwdriver and remove the shifting spring. Grasp the spring just back of the crook in the spring and form the spring slightly so that when it is remounted the tension will be within the specified limits. Remount the shifting spring and tighten the mounting screw securely. Check the tension and, if necessary, readjust using the No. 507A spring adjuster. Remount the timer, making sure requirements 2.06, 2.07, 2.08, 2.10, 2.14, and 2.32(b) are met.

### 3.11 Armature Travel (Rq 2.11)

(1) To adjust the armature travel, turn the armature adjusting nut with the No. 551A wrench until the 0.053-inch end of the No. 142A gauge can be inserted loosely between the armature stop plate and pole piece

as shown in Fig. 22 and the 0.060-inch end of the gauge, if it can be inserted without forcing, does so with a snug fit.

### 3.12 Armature Adjusting Screw Clearance (Rq 2.12)

(1) Before adjusting for clearance between the armature and armature adjusting screw, dismount the timer as covered in 3.003. Loosen the armature mounting screws with the KS-6854 screwdriver and move the armature until there is a clearance between the armature and the adjusting screw. Tighten the armature mounting screws securely. Remount the timer, making sure requirements 2.06, 2.07, 2.08, 2.10, 2.14, and 2.32(b) are met.

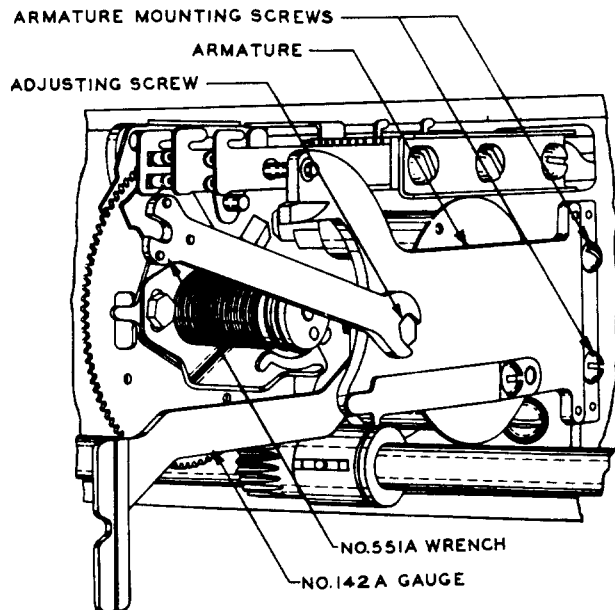

Fig. 22 - Method of Adjusting Armature Travel

### 3.13 Index Finger Position (Rq 2.13)

(1) Use the No. 485A pliers to adjust the position of the index finger.

### 3.14 Pinion Position (Rq 2.14)

(1) If it is necessary to change the position of a pinion with respect to its gear, adjust the tip of the shifting spring (Fig. 23) away from the armature with the No. 485A pliers to position the pinion nearer the gear or adjust the tip of the shifting spring toward the armature to position the pinion farther from the gear. After adjusting the tip of the shifting spring, check requirement 2.10 and, if necessary, readjust the shifting spring tension as outlined in 3.10(2). Check that requirements 2.07(b) and 2.32(b) are met.



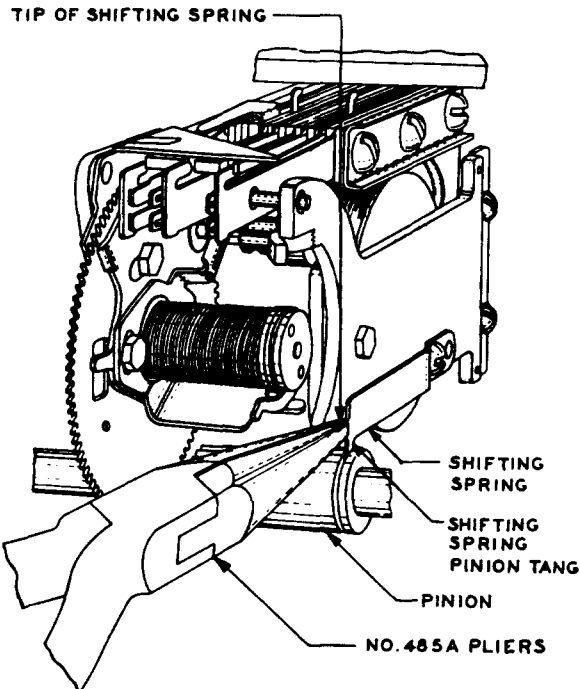

Fig. 23 - Method of Adjusting Pinion Position

### 3.15 Gear Stop Pawl Position (Rq 2.15)

(1) Remove the timer in order to check or adjust the pawl spring tension. Use the No. 485A pliers to change the tension in the pawl spring. If the pawl does not drop freely from the gear stop, increase the tension but not to exceed the tension specified in requirement 2.15(d). If after increasing the tension of the pawl spring, as specified above, requirements 2.15(a) and (b) are not met, clean the pawl by applying a few drops of petroleum spirits at the pawl bearing, between the pawl and the gear and between the pawl and the mounting bracket using a toothpick. If these requirements are still not met, refer the matter to the supervisor. After checking or adjusting, remount the timer and check that requirements 2.06, 2.07, 2.08, 2.10, 2.14, 2.29, and 2.32(b) are met.

### 3.16 Gear Stop Spring Position (Rq 2.16)

(1) To adjust the position of the gear stop spring, first dismount the timer. Adjust the stop spring with the No. 485A pliers applied near the base of the spring. In adjusting the stop spring away from the gear wheel, the pliers should be applied so that they will span both the spring and the frame, thus forcing the spring away from the gear wheel. Remount the timer, making sure requirements 2.06, 2.07, 2.08, 2.10, 2.14, and 2.32(b) are met.

### 3.17 Engagement of Timer Gear and Governor Pinion (Rq 2.17)

(1) If there is no backlash between the gear and governor pinion, refer the matter to the supervisor.

### 3.18 Contact Alignment (Rq 2.18)

### 3.19 Spacer and Stud Clearance (Rq 2.19)

(1) If the contacts on the bifurcated armature spring do not line up properly or a spacer or stud rubs on a spring, it is an indication that the springs are twisted or have shifted in the assembly. Straighten twisted springs as outlined in 3.23. If springs are straight or if after straightening twisted springs contacts do not line up properly, it is an indication the springs have shifted in the assembly. In this case, refer the matter to the supervisor.

### 3.20 Spring Tension (Rq 2.20)

### 3.21 Contact Pressure of "A" Cam Contacts (No. 1D and D-99326 Timers) (Rq 2.21)

(1) Use the No. 505A, No. 506A, or No. 507A spring adjuster to adjust for spring tension or contact pressure and adjust the solid and bifurcated springs, as required, applying the adjuster on the thinner part of the springs where the springs leave the clamping plate and insulators as shown in Fig. 24. After adjusting, make sure requirements 2.22, 2.23, 2.24, 2.25, 2.26, and 2.27 are met.

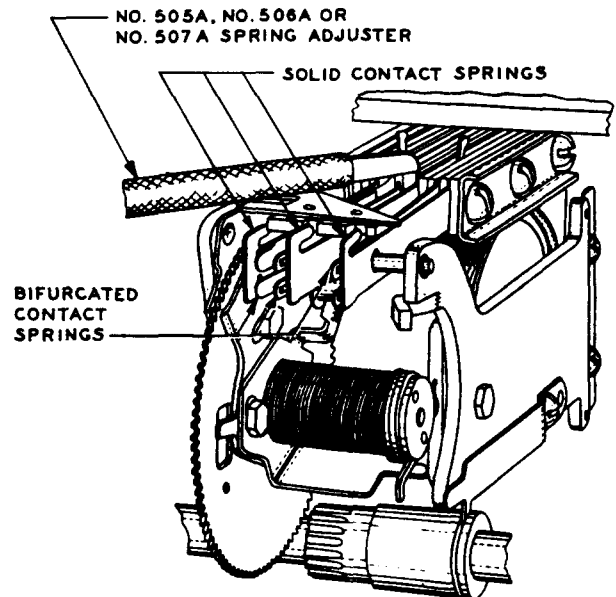

Fig. 24 - Method of Adjusting Spring Tension

3.22 Contact Separation (Rq 2.22)

- (1) The spring spacer so spaces the "B" cam bifurcated contact spring (No. 1D and D-99326 timers only) with respect to the solid contact spring that no adjustment for contact separation should be necessary, if the springs are straight in accordance with requirement 2.30 and the contacts on the bifurcated contact springs are in approximately the same vertical line.
- (2) To adjust the contact separation of the contacts controlled by the armature or the "A" cam contact (No. 1D and D-99326 timers only), adjust the spring tangs to the right or left, as required, using the No. 505A, No. 506A, or No. 507A spring adjuster. After adjustment, make sure requirements 2.20, 2.21, 2.24, 2.25, and 2.26 are met.

3.23 Spring Gauging (Rq 2.23)3.24 Contact Follow (Rq 2.24)

- (1) To adjust for spring gauging or contact follow, adjust the spring tangs to the right or left, as required, using the No. 505A, No. 506A, or No. 507A spring adjuster. After adjustment, make sure requirements 2.20, 2.21, 2.26, and 2.27 are met.

- (2) If both contacts on the bifurcated springs do not make contact in the closed position of the contacts, it may be due to a twist in the spring or misalignment of the two prongs of the bifurcated spring. Correct for a twisted spring by using the No. 505A or No. 506A spring adjuster applied near the point where the spring leaves the insulators. To correct misalignment of the prongs of the bifurcated spring, use the No. 505A or No. 506A spring adjuster and adjust the upper or lower prong of the bifurcated spring. It is recommended that in adjusting as covered above the two prongs of the bifurcated springs be adjusted to make contact with the opposing contacts as near simultaneously as possible.

3.25 Bifurcated Spring Position (Rq 2.25)

- (1) If the upper edge of the studs on the bifurcated springs do not line up properly with the outer edge of the associated cams, it may be due to a twist in the springs. If necessary, straighten a spring with the No. 505A, No. 506A, or No. 507A spring adjuster. If the springs are straight or after straightening a twist in a spring the condition is not corrected, it is an indication that the springs have shifted in the assembly. In this case, refer the matter to the supervisor. After straightening springs, check that requirements 2.20, 2.21, 2.22, and 2.23 are met.
- (2) If there is insufficient clearance between a spring stud and the timer gear, adjust the tang of the associated solid contact spring with the No. 506A or No. 507A spring adjuster sufficiently to insure a satisfactory clearance. After making this ad-

justment, make sure requirements 2.20, 2.21, 2.22, and 2.23(a) are met.

3.26 "A" Cam Position (Rq 2.26)3.27 "B" Cam Position (No. 1D and D-99326 Timers) (Rq 2.27)

- (1) "A" Cam Position (No. 1C and D-99325 Timers): To adjust the "A" cam, loosen the "A" cam and retractile spring operating finger clamping screws with the No. 551A wrench. Rotate the gear, as required, to obtain access to the clamping screws. Adjust the position of the "A" cam with the KS-6854 screwdriver inserted in the slot at the front of the gear, by moving the adjusting lever of the "A" cam up or down, as required, with the screwdriver. Tighten the clamping screw just back of the slot in the gear securely. Rotate the gear and tighten the other two clamping screws securely.

- (2) "A" Cam Position (No. 1D and D-99326 Timers): Adjust the "A" cam position as outlined in (1). However, after adjustment is made, tighten only the clamping screw just back of the slot in the gear and the "A" cam clamping screw. Then adjust the "B" cam position as outlined in (3).

- (3) "B" Cam Position (No. 1D and D-99326 Timers): To adjust the "B" cam after adjusting the "A" cam, loosen the clamping screw just back of the gear slot, or if only the "B" cam is being adjusted, loosen both retractile spring operating finger clamping screws with the No. 551A wrench. Manually rotate the timer gear eleven teeth from the normal position and operate the armature to hold the gear in this position. If the "B" cam is in front of the stud on the "B" cam bifurcated spring, position the "B" cam so that it is back of the stud. Now adjust the "B" cam by moving the "B" cam bracket up or down with the KS-6854 screwdriver until the contacts just make. Tighten the clamping screw just back of the slot in the gear. Release the armature and check that the B contacts are open when the timer gear is rotated nine teeth from its normal position. If necessary, again adjust the cam until the contacts are open with gear nine teeth from the time of closure of the "A" cam contacts and closed at eleven teeth from the time of closure of the "A" cam contacts. Tighten both "B" cam clamping screws securely. Check timing requirement 2.33(b)(3) which should be met after adjusting the "B" cam as outlined above. If the timing requirement is not met, again adjust the "B" cam to give a greater or less time interval, as required to meet requirement 2.33(b)(3).

3.28 Timer Gear Retractable Spring Clearance (Rq 2.28)

- (1) If there is insufficient clearance between the end of the retractile spring which protrudes through the timer gear and the timer frame, rotate the gear until the end of the spring is accessible and cut the

end off as close to the gear as possible with the 5-inch diagonal pliers.

**3.29 Timer Gear Retractable Spring Tension**  
(Rq 2.29)

(1) If the gear fails to restore to normal against the specified tension when moved from four to six teeth from the normal position, lubricate the shaft of the timer gear as covered in 3.02(4). If after the shaft has been lubricated the gear still fails to return to normal, it is an indication that the tension of the retractile spring is too low, in which case refer the question to the supervisor.

(2) If the gear fails to return to the normal position as the pawl passes over the gear stop, it is an indication that the tension of the pawl spring is excessive. Remove the timer from its mounting as covered in 3.003 and check the tension of the pawl spring as the gear stop is passing under the end of the pawl. To do this, use the No. 70D gauge applied to the front end of the pawl when the pawl is lifted to its highest point by the gear stop. If the tension of the pawl spring measured in this manner exceeds 40 grams, readjust the pawl spring using the No. 485A pliers so that there is a slight clearance between the pawl spring and the pawl when the pawl is resting against the pawl stop. This clearance should not exceed the value specified in requirement 2.15(c). In case the tension of the pawl spring is less than 40 grams, reduce the tension of the pawl spring using the No. 485A pliers. In this case, however, the end of the spring should rest on the pawl when the pawl is resting against the pawl stop. Remount the timer as covered in 3.003.

**3.30 Straightness of Springs** (Rq 2.30)

**3.31 Separation Between Springs** (Rq 2.31)

(1) If the springs are not straight or there is insufficient clearance between the springs, correct by adjusting the springs where they are bent or where the clearance is insufficient with the No. 505A, No. 506A, or No. 507A spring adjuster. If necessary, dismount the timer in order to obtain access to the part of a spring needing adjustment.

(2) Kinked Springs: Do not straighten kinked springs unless the kink interferes with proper adjustment of the spring assembly. Removing kinks tends to weaken the spring and to shorten the life of the spring assembly. Normally straight springs that have been adjusted should have no sharp bends due to adjustment. A gradual bow, however, is permissible.

**3.32 Electrical Requirements** (Rq 2.32)

(1) If the timer does not operate on the specified operate current, adjust as follows, checking for timer operation after each adjustment.

(a) Decrease the tension of the armature spring against the armature stud toward a minimum.

(b) Decrease the tension of the shifting spring toward a minimum.

If the timer still does not operate satisfactorily, refer the matter to the supervisor.

**3.33 Timing Requirements** (Rq 2.33)

(1) If the timing requirements are not met, recheck all mechanical requirements and make adjustments as required. If the timing requirements are still not met, it is an indication that the motor requires lubrication or is defective. In this case, relubricate the motor as covered in 3.02(8). If the requirement is still not met, replace the motor.

**REASONS FOR REISSUE**

1. To add the Nos. 51D, 52B, and D-179539 drives.
2. To revise the requirement for lubricating the motor [2.02(d)].
3. To revise the requirement for the recommended lubrication intervals [2.02(e)].
4. To revise the requirement for the engagement of motor and driving shaft gears [2.05(a) and (b)].
5. To add freedom of shaft movement requirement for the Nos. 51D, 52B, and D-179539 drives (2.08).
6. To revise the requirement for checking the pinion position (2.14).
7. To add contact alignment requirement for timers equipped with heavy contacts (2.18) and associated Fig. 12.
8. To revise the requirement for spring gauging (2.23(a) and (c) previously covered in 2.18).
9. To revise the check method for the requirement covering timers equipped with stop pawl (2.29).
10. To add timing requirements for the Nos. 51D, 52B, and D-179539 timers (2.33) and associated Figs. 19, 20, and 21.
11. To revise the list of tools, gauges, materials, and test apparatus (3.001).
12. To add procedure for replacing nonrecoilable motors [3.02(8)].
13. To add procedure for adjusting twisted or misalignment of the bifurcated springs [3.23 and 3.24(2)] previously covered in [3.18 and 3.19].