

KS-19717 L1, L2, L4, AND L5 TAPE PRINTERS PIECE-PART DATA AND REPLACEMENT PROCEDURES

1. GENERAL

1.01 This section covers the information necessary for ordering parts to be used in the maintenance of KS-19717 L1, L2, L4, and L5 tape printers. It also covers approved procedures for replacing these parts. The L1 and L2 tape printers are rated "Manufacture Discontinued" and replaced by the L4 and L5, respectively. The L11 low tape alarm replaces the "Manufacture Discontinued" L10 alarm.

1.02 This section is reissued to

- Revise and clarify procedures for replacing parts in 3.05 through 3.11
- Add Fig. 7, 8, and 9.

1.03 Part 2 (PIECE-PART DATA) of this section covers the piece-part numbers and the corresponding names of the parts which it is

practical to replace in the field in the maintenance of the KS-19717 L1, L2, L4, and L5 tape printers. The L3 and L6 tape printers are covered in Section 030-342-802.

1.04 Part 3 (REPLACEMENT PROCEDURES) of this section covers the approved procedures for the replacement of the parts covered in Part 2.

1.05 References to left and right in this practice are based on viewing the top of the printer from its front.

2. PIECE-PART DATA

2.01 Fig. 1 through 6 included in this part show the various piece parts in their proper relation to other parts of the tape printer. The piece-part numbers of the various parts are given with the names of the parts as assigned by the manufacturer.

SECTION 030-342-801

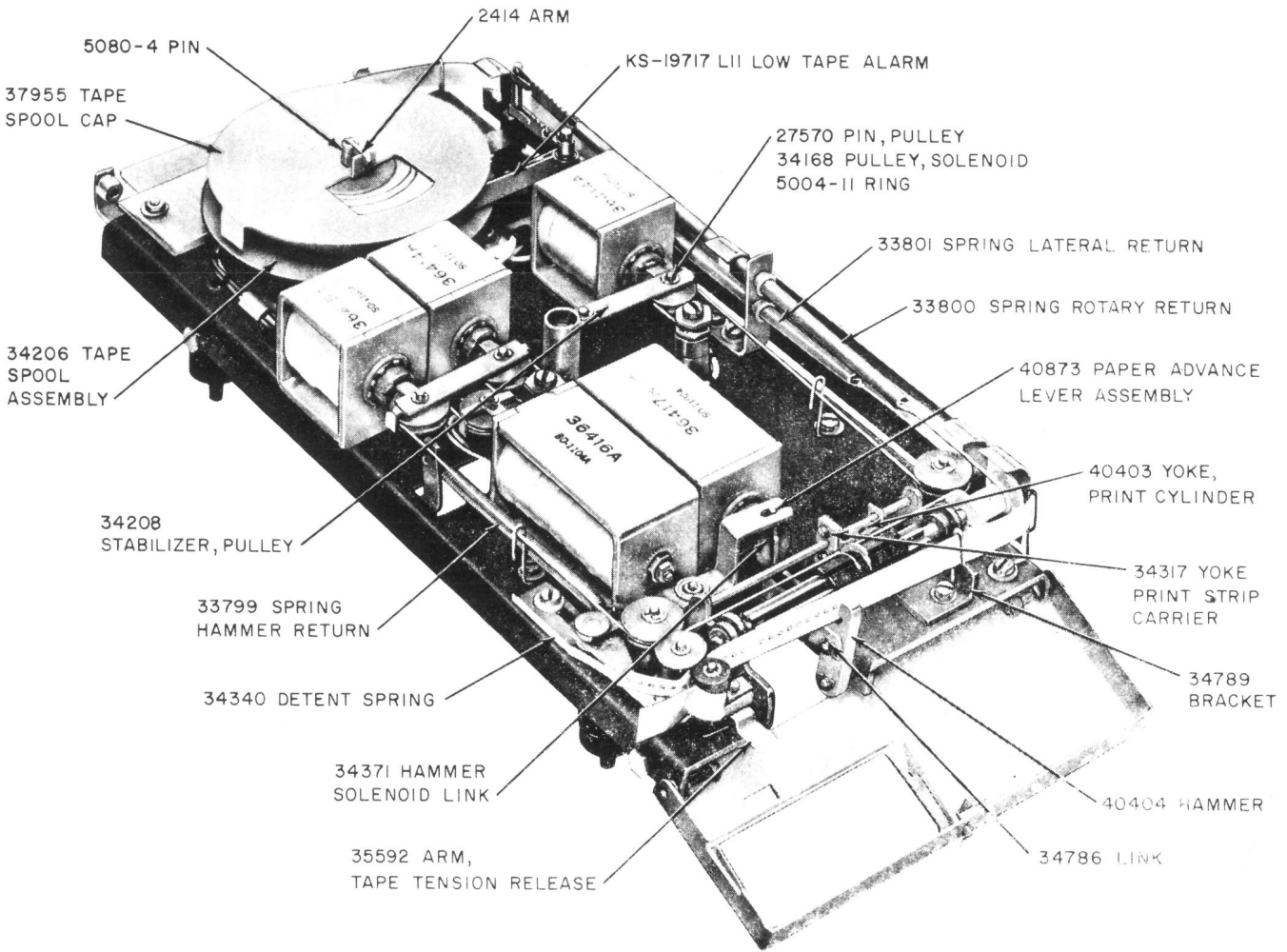

Fig. 1—KS-19717 L5 Tape Printer—Cover Removed

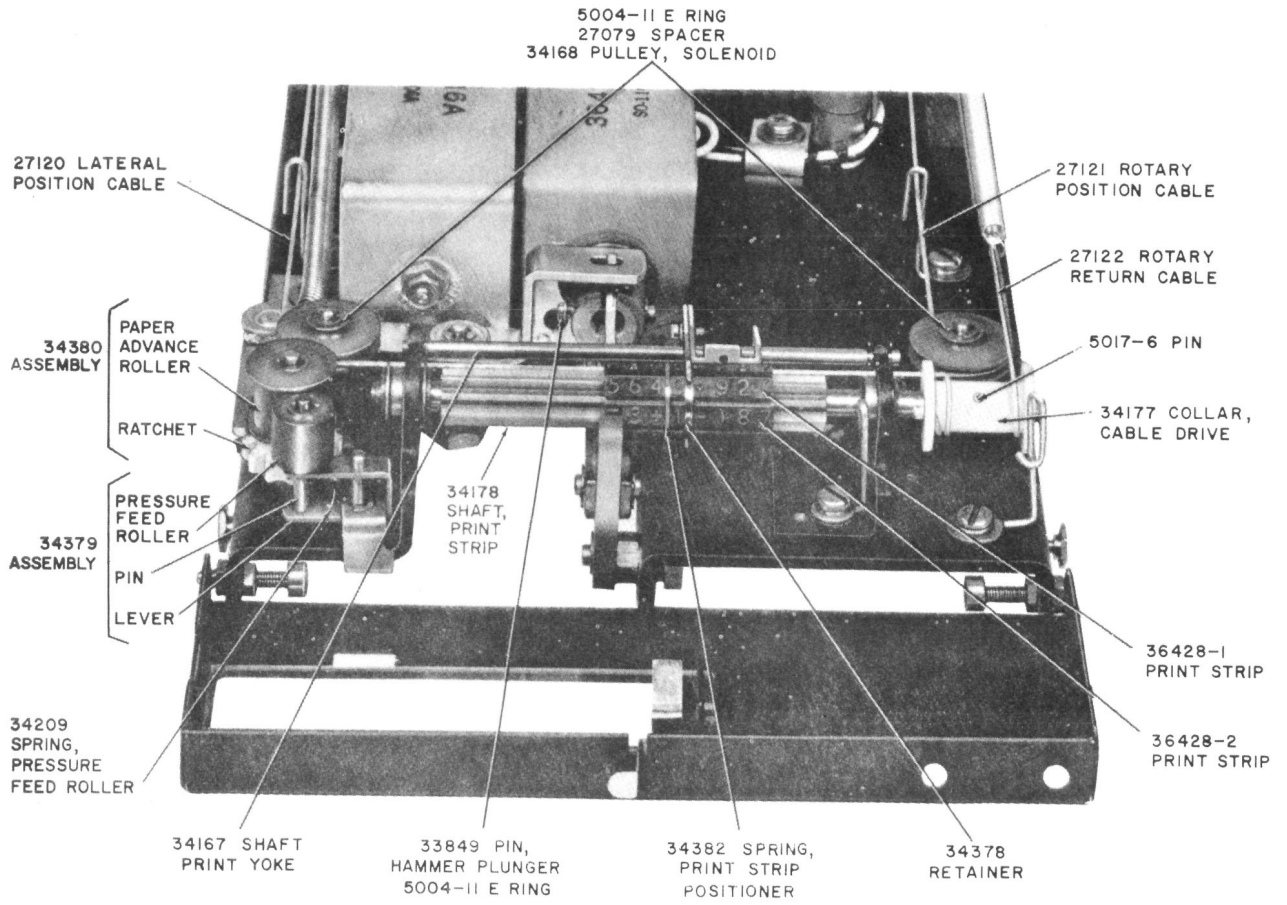

Fig. 2—KS-19717 L5 Tape Printer Showing Print Segments

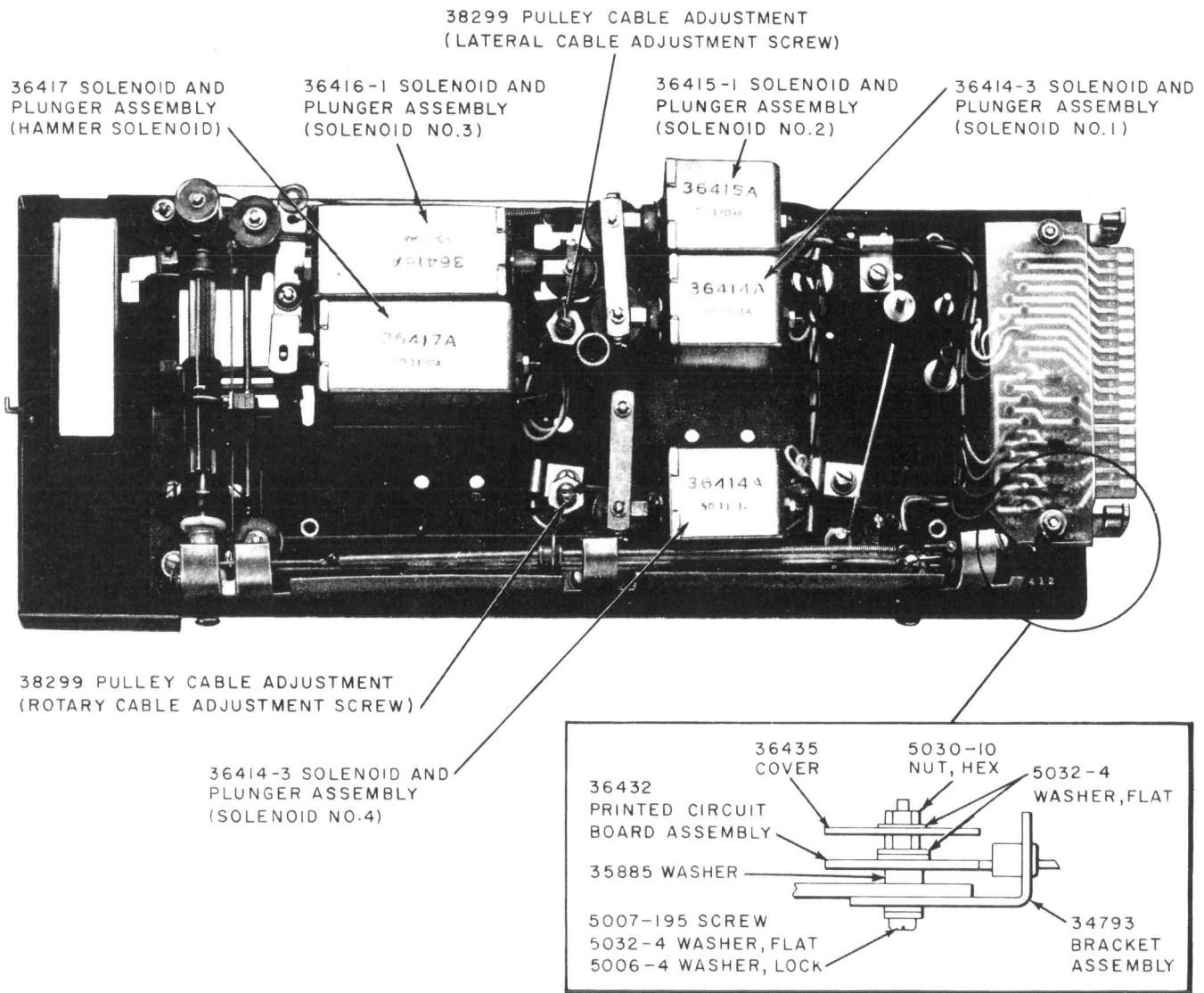

Fig. 3—KS-19717 L5 Tape Printer Showing Circuit Board

5007-83 SCREW
5030-2 HEX NUT
5006-2 LOCKWASHER

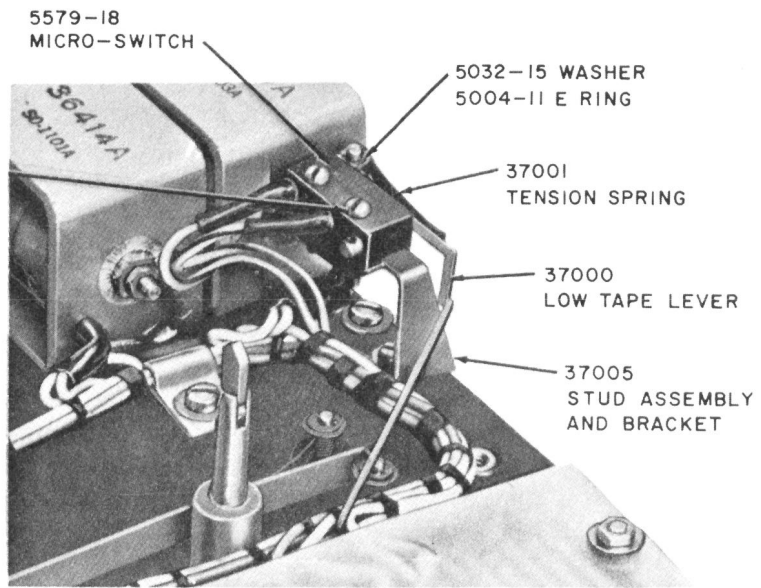
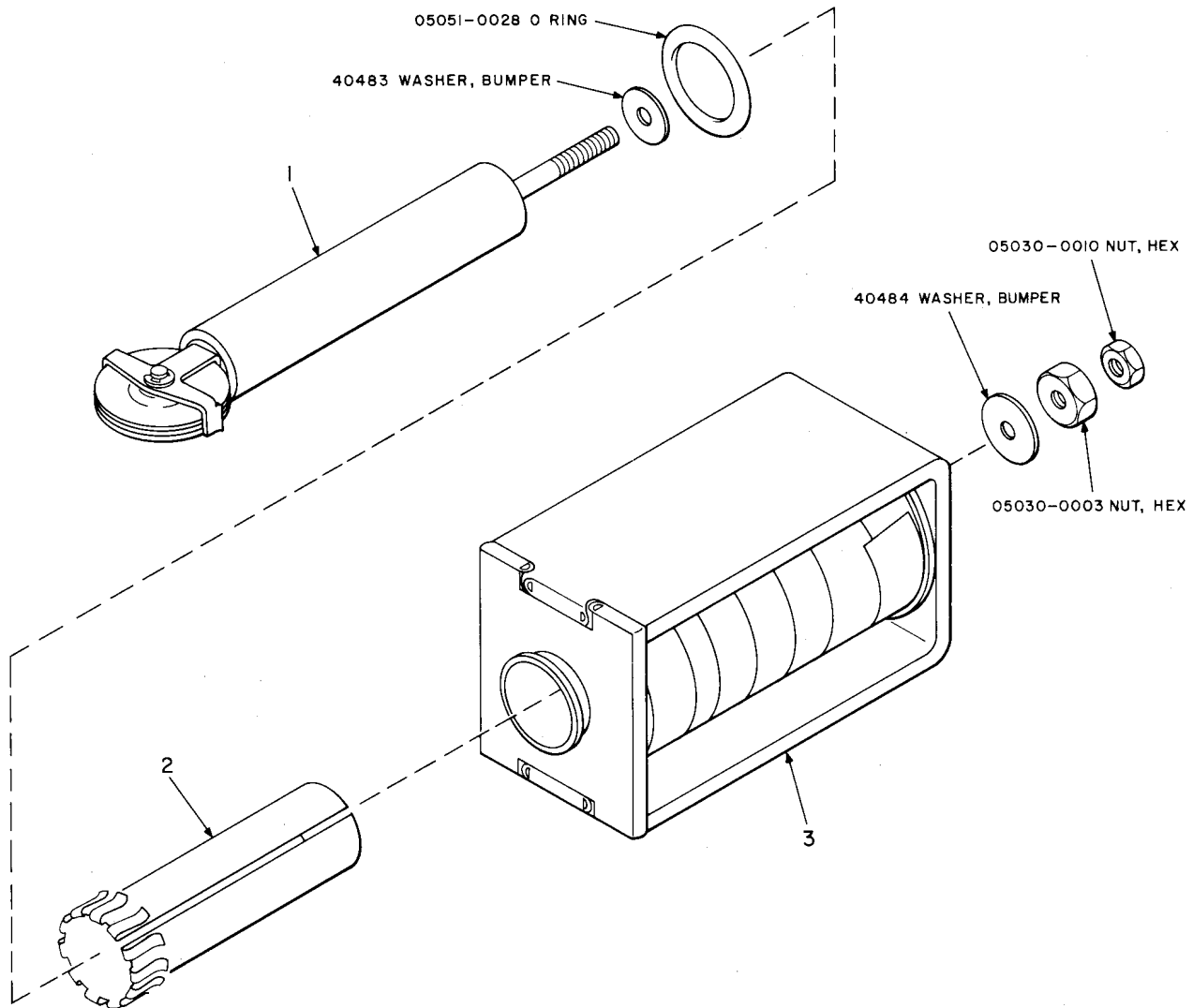

Fig. 4—KS-19717 L10 Low Tape Alarm



| | | SOLENOID AND PLUNGER ASSEMBLY | | | |
|---|-------------------------|-------------------------------|---------|---------|-------|
| | | 36414-3 | 36415-1 | 36416-1 | 36417 |
| 1 | PLUNGER, SOLENOID | 35016 | 35017 | 35015 | 36266 |
| 2 | LINER | 35038 | 35039 | 35040-3 | 35604 |
| 3 | COIL AND FRAME ASSEMBLY | 40703 | 40702-1 | 40701-1 | 40700 |

TPA 513793

Fig. 5—Typical Solenoid and Plunger Assembly

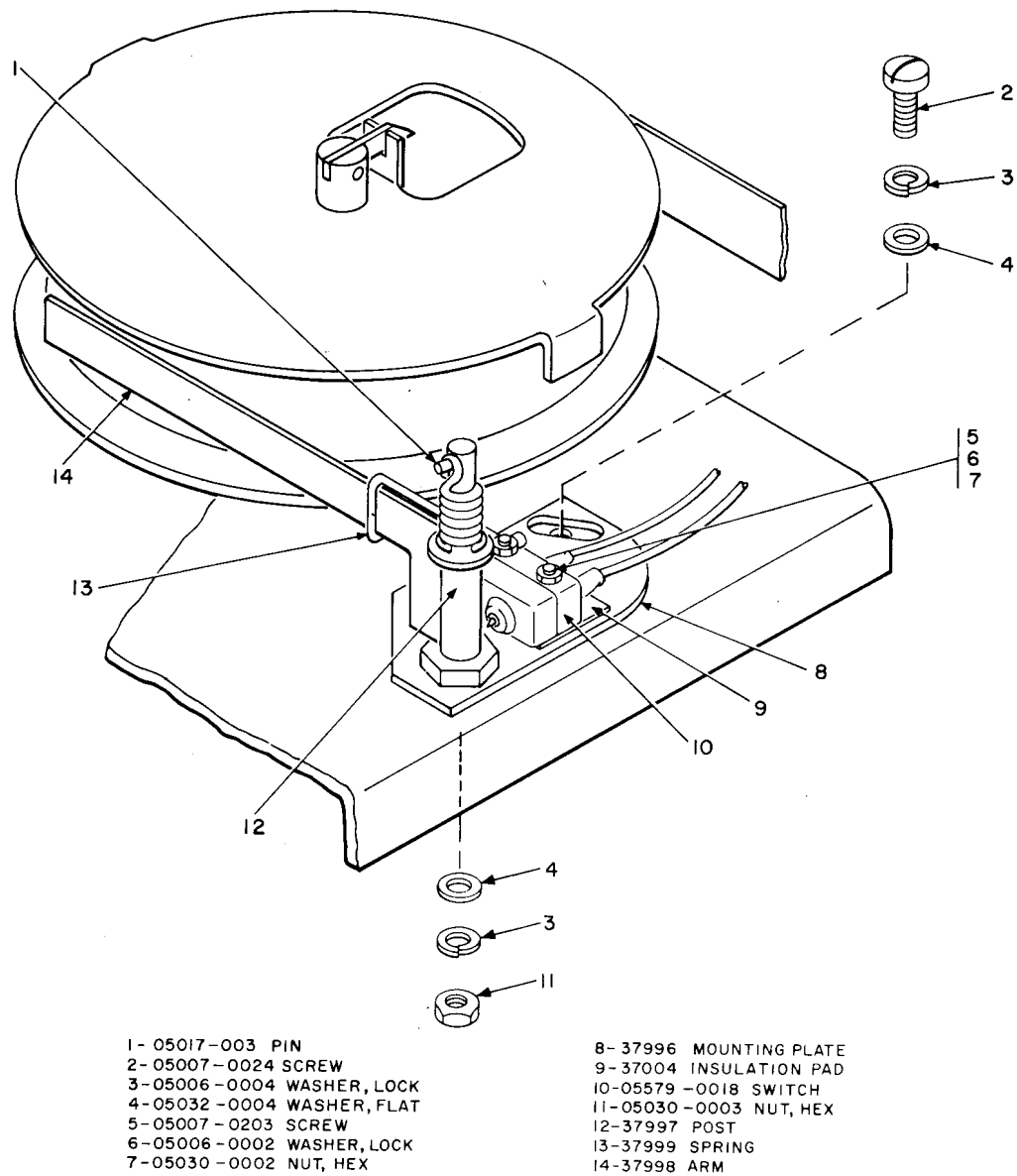

Fig. 6—KS-19717 L11 Low Tape Alarm

2.02 When ordering parts for replacement purposes, give the part number, name of the part, and the KS number the part is used on. For example:

36428-1 print strip for KS-19717 L5 tape printer.

Do not refer to the BSP number or to any information shown in parentheses.

3. REPLACEMENT PROCEDURES

3.01 List of Tools

CODE OR
SPEC NO.

DESCRIPTION

474A

3/16- and 1/4-Inch double-end box wrench

| | DESCRIPTION |
|------|---|
| 388A | 3/16- and 1/4-Inch open double-end flat wrench |
| 417A | 1/4- and 3/8-Inch open double-end flat wrench |
| 418A | 5/16- and 7/32-Inch open double-end flat wrench |
| — | 3-Inch C screwdriver |
| — | B Long-nose pliers |

3.02 To facilitate the replacement of any part of the tape printer, disconnect and dismount the printer and remove the cover. After making the necessary replacement of parts, replace the cover, remount and reconnect the tape printer.

3.03 After making any replacement of parts, check the tape printer and make required adjustments in accordance with requirements and procedures specified in Section 030-342-701.

3.04 No replacement procedures are specified for screws or other similar parts when the replacement consists of a simple operation.

REPLACEMENT OF ROTARY POSITION AND LATERAL RETURN CABLES

3.05 Rotary Position Cable: Replace the rotary position cable with the solenoids de-energized. The symbol □ should be in alignment with the print hammer when the rotary position cable is secured to the cable drive collar. To replace the rotary position cable:

- (1) Cut a piece of cable approximately 8 inches long, tie a knot in one end of the cable, singe the excess cable close to the knot with a match or lighter to prevent unraveling, and thread the opposite end of the cable downward through the hole in the rotary cable adjustment screw.
- (2) Wind the cable cw (viewed from top of unit) from 3/4 to a full turn around the rotary cable adjustment screw.
- (3) Thread the cable cw (viewed from top of unit) around the rotary solenoid pulley (solenoid No. 4).
- (4) Make one complete turn cw (viewed from top of unit) around the cable drive collar, thread the end of the cable through the hole on the left in the cable drive collar, tie a knot in the end of the cable, and singe the excess cable at the knot. ♦See Fig. 7.♦

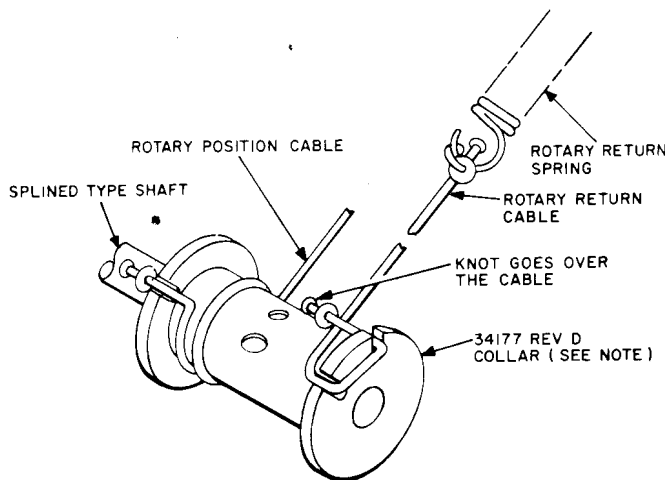

NOTE :
 PLASTIC COLLAR WILL HAVE 2 SLOTS SO THAT KNOT RETURNS BACK TO INSIDE OF END FLANGE TO PREVENT TEARING OF PAPER.

Fig. 7—Threading Diagram for Rotary Return Cable and Rotary Position Cable

3.06 Rotary Return Cable: Replace the rotary return cable with the solenoids de-energized. The symbol □ should be in alignment with the print hammer when the rotary return cable is secured to the cable drive collar.

- (1) Cut a piece of cable approximately 3 inches long, tie a knot in one end of the cable, singe the excess cable close to the knot to prevent unraveling, and thread the opposite end of the cable through the hole on the right in the cable drive collar. ♦See Fig. 7.♦
- (2) Make 1/4 turn cw (viewed from top of unit) around the cable drive collar and tie the free end of the cable to the rotary return spring.

Note: The rotary return spring should be approximately 1/4 inch from making contact with the lateral cable pulley when the No. 4 solenoid is energized. ♦See Fig. 8.♦

3.07 Lateral Position Cable: Replace the lateral position cable with the solenoids de-energized. The character □ should be aligned with the print hammer when the lateral position cable is secured to lateral return spring and the cable is clamped on the carrier yoke. To replace the lateral position cable:

- (1) Cut a piece of cable approximately 14 inches long, tie a knot in one end of the cable, singe the excess cable close to the knot to prevent unraveling, and thread the opposite end of the cable downward through the hole in the lateral cable adjustment screw.

- (2) Make from 3/4 to a full turn ccw (viewed from top of unit) around the lateral cable adjustment screw.

- (3) Thread the cable around the pulleys on solenoids 1, 3, and 2 successively. Continue to thread the cable around the left lateral pulley, through the cable clamp on the yoke, and around the right lateral pulley. Tie the lateral position cable to the lateral return spring so there is approximately one inch of cable between the lateral cable pulley and the end of the lateral return spring. Singe the end of the cable to prevent unraveling.

- (4) ♦On older units,♦ clamp the lateral position cable with the cable clamp on the carrier yoke by securely tightening the clamping screw. ♦On new units, attach as shown in Fig. 9.♦

Note: When all lateral solenoids are energized, the end of the lateral return spring should be positioned approximately 1/4-inch from the lateral cable pulley. ♦See Fig. 8.♦

REPLACEMENT OF PRINT STRIPS

3.08 If any of the print strips should require replacement due to wear or damage, use the following procedure:

- (1) Remove the two bracket mounting screws and pull the two locating pins.♦
- (2) Remove the retaining ring on the print strip shaft.

| NOMINAL VOLTAGE | CABLE | SOLENOID DE-ENERGIZED | | REFERENCE SOLENOID ENERGIZED | |
|-----------------|---------|-----------------------|-------------------|------------------------------|-------------|
| | | DISTANCE "A" | RESULTING TENSION | "A" TENSION | "A" TENSION |
| 48 | ROTARY | 1 1/4" | 4 OZ | 3/8 | 5 1/4 OZ |
| | LATERAL | 1 5/8" | 3.5 OZ | 3/4 | 4 3/4 OZ |

ROTARY AND LATERAL RETURN SPRINGS SHALL BE ENGAGED IN "STARTING HOOK" NO. 5 EACH NOTCH (3/32 IN.) INCREASES OR DECREASES THE TENSION BY 1/8 OUNCE, GIVING A TOTAL RANGE OF 1 OUNCE. THIS ADJUSTMENT CAN BE USED TO COMPENSATE FOR LOAD VARIATIONS IN DIFFERENT SPRINGS.

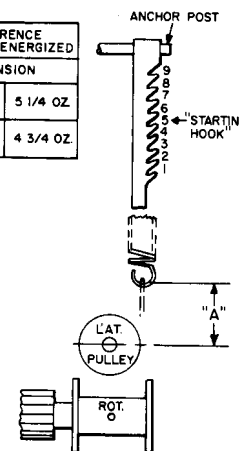

Fig. 8—Rotary and Lateral Return Spring Attachment and Adjustment

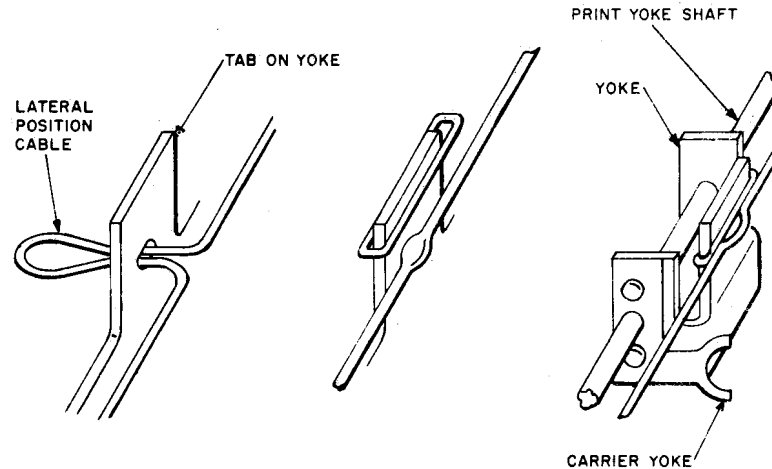

Fig. 9—Method of Attaching Lateral Position Cable to Carrier Yoke

- (3) Remove the retaining ring, washer, and right lateral cable pulley.
- (4) Remove the two print yoke shaft retaining rings and slide the yoke shaft to the right and out of the print strip carrier yoke.
- (5) Lift the carrier yoke off the print strip retainer.
- (6) Remove the print strip and shaft assembly by lifting the bracket and sliding it and the print strip shaft to the right.
- (7) Slide the retainer and the print strips to the left on the print strip shaft. Use a rubber band to prevent disengagement of the print strips from the grooves in the shaft.
- (8) Remove the defective print strip.
- (9) Insert the new print strip. Do not force the print strip into its groove.
- (10) Slide the print strips and retainer to the right onto the center section of the print shaft.
- (11) Reverse the procedure in steps (1) through (6) to reassemble the print shaft assembly, yoke shaft, and mounting bracket.

REPLACEMENT OF SOLENOID LINER

3.09 To replace a solenoid liner, use the following procedure:

- (1) Remove the two nuts on the solenoid plunger.
- (2) Roll the O-ring off the solenoid tubing flange and onto the plunger. Remove the mounting nuts, disconnect the wires, and tilt the solenoid up to clear the base plate and studs.
- (3) Slide the plunger away from the solenoid coil and the frame assembly away from the plunger.
- (4) Pull the old liner out of the solenoid.
- (5) Insert the new liner and reassemble the solenoid to the base plate.
- (6) Install the O-ring over the insert so the fringes on the liner are held in place by the O-ring.
- (7) Refer to BSP 030-342-701 for procedures necessary for readjusting the solenoid.

REPLACEMENT OF HAMMER SOLENOID

3.10 To replace a defective hammer solenoid, use the following procedures:

- (1) Remove the hammer plunger pin by removing the left retaining ring and pulling the pin toward the right.
- (2) Remove the two retaining rings which secure the hammer and linkage to the posts in the baseplate.

- (3) Pivot the hammer linkage toward the front of the machine and slide the hammer and linkage to the left and up to clear the posts.
- (4) Slide the insulation sleeving away from the terminals at the rear of the solenoid and unsolder the wire leads.
- (5) Remove the two hammer solenoid mounting screws from the under side of the baseplate and remove the defective solenoid.
- (6) Position the new solenoid, resolder the wire leads, and slide the insulation sleeving in place over the terminals.
- (7) Loosely engage the solenoid mounting screws or nuts.
- (8) Reverse the procedure in steps (1) through (3) to reassemble the hammer linkage and hammer to the baseplate.

Note: When tightening solenoid mounting screws (where screws are used instead of nuts), be sure screws do not project through the solenoid frame and damage solenoid winding.

- (9) Perform the hammer solenoid and tape advancement adjustment.

REPLACEMENT OF PRINT POSITIONING SOLENOIDS

3.11 To replace any one of the print positioning solenoids, use the following procedure:

- (1) Remove upper E-rings and pulley pin to remove solenoid pulley.
- (2) Remove the solenoid mounting screws or nuts and disconnect the leads of the solenoid.
- (3) Remove the defective solenoid.
- (4) Reverse the above procedure to install the new solenoid.

Note: When tightening solenoid mounting screws (where screws are used instead of nuts), be sure screws do not project through the solenoid frame and damage solenoid winding.

- (5) Perform the plunger stroke travel adjustment, lateral or rotary cable adjustments, and hammer solenoid and tape adjustment as required.

REPLACEMENT OF DIODES

3.12 There is no replacement procedure for defective diodes. *If a diode is found to be defective, replace the entire diode board assembly.*

REPLACEMENT OF DIODE BOARD ASSEMBLY

3.13 If the diode board assembly should require replacing, use the following procedure:

- (1) Remove the tape spool cap and tape spool.
- (2) Remove the retaining ring which secures the tape spool assembly.
- (3) Remove the tape spool assembly.
- (4) Remove the two nuts and the flat washers associated with the printed circuit board and remove the plastic cover.
- (5) Mark the wires for identification and unsolder the wires.
- (6) Remove the circuit board.
- (7) Install the new board making sure that the two fiber washers are in place between the circuit board and the base plate.
- (8) Solder the wires to the new board taking care to prevent shorting or grounding of the leads.
- (9) Replace parts removed in (1) through (4) in reverse order of removal.

REPLACEMENT OF LOW TAPE ALARM

3.14 *KS-19717 L10 Low Tape Alarm (used on KS-19717 L1 printer):* To remove the switch, unsolder the switch leads from terminals 10 and 11, and remove switch mounting hardware and switch from the bracket assembly. Replace the switch by reversing the procedure. To remove the low tape lever, remove the E-ring, washer, and lever from the mounting stud. Replace the lever by reversing the procedure.

SECTION 030-342-801

3.15 *KS-19717 L11 Low Tape Alarm (used on KS-19717 printers other than L1):* To remove the switch, unsolder the switch leads from terminals 10 and 11 and remove the low tape alarm by removing the screw from the switch pivot bracket

and the nut (on the underside of the chassis) from the post. Remove the switch mounting hardware and remove the switch. Replace the switch and low tape alarm by reversing the procedure.