

223-TYPE COAXIAL SWITCHES REQUIREMENTS

CONTENTS	PAGE	CONTENTS	PAGE
1. GENERAL	2	9. Arrangement for Transmission Test of 223-Type Switches Using 40A Test Bay	11
2. PRECAUTIONS	2	10. Arrangement for Transmission Test of 223-Type Switches Using 45A Test Bay	12
3. APPARATUS	6	11. Test Arrangement for Return Loss Measurement of the 223-Type Switch Using 40A Test Bay	13
4. SWITCH CLEANING	6	12. Test Arrangement for Return Loss Measurement of the 223-Type Switch Using 45A Test Bay	14
5. TEST REQUIREMENTS FOR 223A, 223B, AND 223C SWITCHES	7	13. Oscilloscope Trace Appearance for Return Loss Setup	15
6. TEST REQUIREMENTS FOR 223D AND 223E SWITCHES	19	14. Arrangement for Crosstalk Test Using 40A Test Bay	16
Figures		15. Arrangement for Crosstalk Test Using 45A Test Bay	17
1. 223C Coaxial Switch, Assembled	3	16. Test Arrangement for 223-Type Switch Timing Test	19
2. 223B Coaxial Switch, Disassembled, Top View	4	17. Block Magnets	20
3. 223D Coaxial Switch, Assembled	5	18. Indicating Circuit	20
4. 223D Coaxial Switch, Cover Removed	5	19. Insertion and Isolation Loss/Test Circuit	20
5. 223A Coaxial Switch Schematic (Shown in Normal Released Condition)	6	20. Return Loss Test Circuit	21
6. 223E Coaxial Switch Schematic (Shown in Normal Released Condition)	6	21. Bridging Time Check Test Circuit	23
7. Power Cable to Connect 35-Type Test Set to J68333 Test Bench	7	22. Timing Chart (S1 to ON)	23
8. Test Arrangements to Operate 223-Type Switch	11	23. Timing Chart (S1 to OFF)	23

NOTICE

Not for use or disclosure outside the
Bell System except under written agreement

Tables

A. Crosstalk Test Requirements . . .	18
B. Insertion and Isolation Loss Data . . .	21
C. Return Loss Data (See Note) . . .	22

1. GENERAL

1.01 This section covers the method of making transmission and dc operational tests on the 223A, 223B, and 223C coaxial switches when these switches are used to switch signal circuits at frequencies up to 80 MHz. It also includes test requirements for the 223D and 223E switches. A method of cleaning 223A, 223B, and 223C switches of early manufacture is included.

1.02 The reasons for reissuing this section are listed below:

- (a) To revise Table A to include information from Table B
- (b) To add warnings in Parts 2 and 4
- (c) To add jack termination for crosstalk test
- (d) To add test information to Fig. 12.

Revision arrows have been used to indicate significant changes. The Equipment Test List is not affected.

1.03 The 223-type switch (Fig. 1, 2, 3, and 4) is a high-speed, electromagnetically operated, coaxial-type transfer switch used for switching 75-ohm lines at high frequencies. The 223A, 223B, and 223C switches are reed-type mercury switches, while the 223D and 223E switches are the dry-reed, sealed contact type. The D and E switches are similar although the D switch is designed to operate at 60 Vdc and the E switch at 24 Vdc.

1.04 There are two separate transmission paths through the switches. In all switches, with the switch normal, the paths are path A to AB and path B to OB. With the switches operated, the paths for the 223A, 223B, and 223C switches are path A to OA and path B to AB. See Fig. 5. For the 223D and 223E switches, these paths are path A to OB and path B to AB. See Fig. 6.

1.05 In the 223A, 223B, and 223C switches, jack OB is provided so in normal (nonoperated or released) condition the input B can be terminated by a 75-ohm circuit or termination.

1.06 In the 223A and 223C switches, jack OA is provided so in the operated condition input A can be terminated.

1.07 In the 223B switch, jack OA is replaced with a built-in 75-ohm resistive termination internal to the switch.

2. PRECAUTIONS

◆Danger: Always wear safety glasses while disassembling, cleaning, and reassembling the 223A, 223B, and 223C switches. The four glass-sealed mercury switching elements of these switches contain hydrogen at a pressure of 100 pounds per square inch.◆

2.01 The switches with tin-plated covers are identified by either a label or a screen-printed instruction message. The text of the instruction is "WARNING—WEAR SAFETY GLASSES WHEN DISASSEMBLING."

2.02 The switches with tin-plated covers may be opened for inspection and cleaning as described in Part 4.

◆Warning: Do not open the 223A, 223B, or 223C switches with solder-dipped covers.◆

2.03 Switches with solder-plated covers are marked with the instruction "CAUTION—DO NOT DROP OR JAR" and "WARNING—DO NOT OPEN."

2.04 Whisker growth will not be found in the cover cavities of these switches. These switches should not be opened for inspection but should be returned for repair if they fail to meet the requirements of this practice.

Caution: Do not stress any of the conductors. To do so may result in a bent lead, broken glass capsule, or a broken solder joint. The dress of the leads is important at high frequencies and should not be disturbed.

- 2.05 When reassembling, make certain no foreign matter has been allowed to enter the cavity areas and cover junction surfaces are clean and dry.

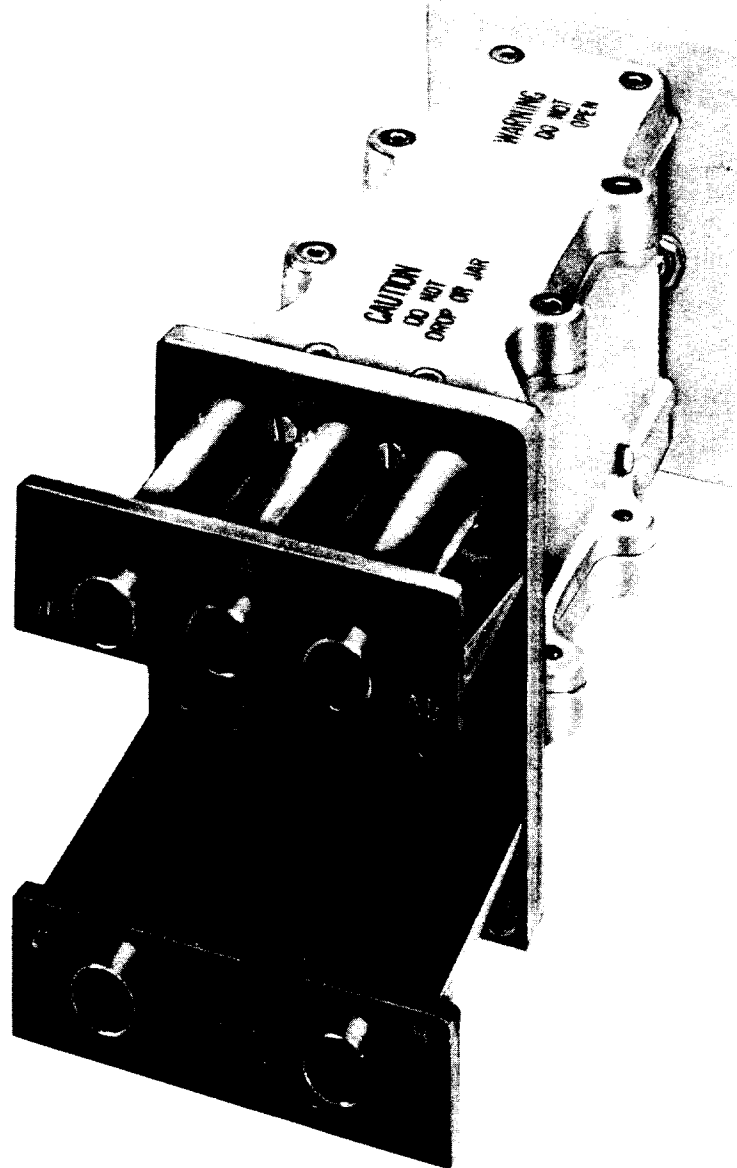

Fig. 1—223C Coaxial Switch, Assembled

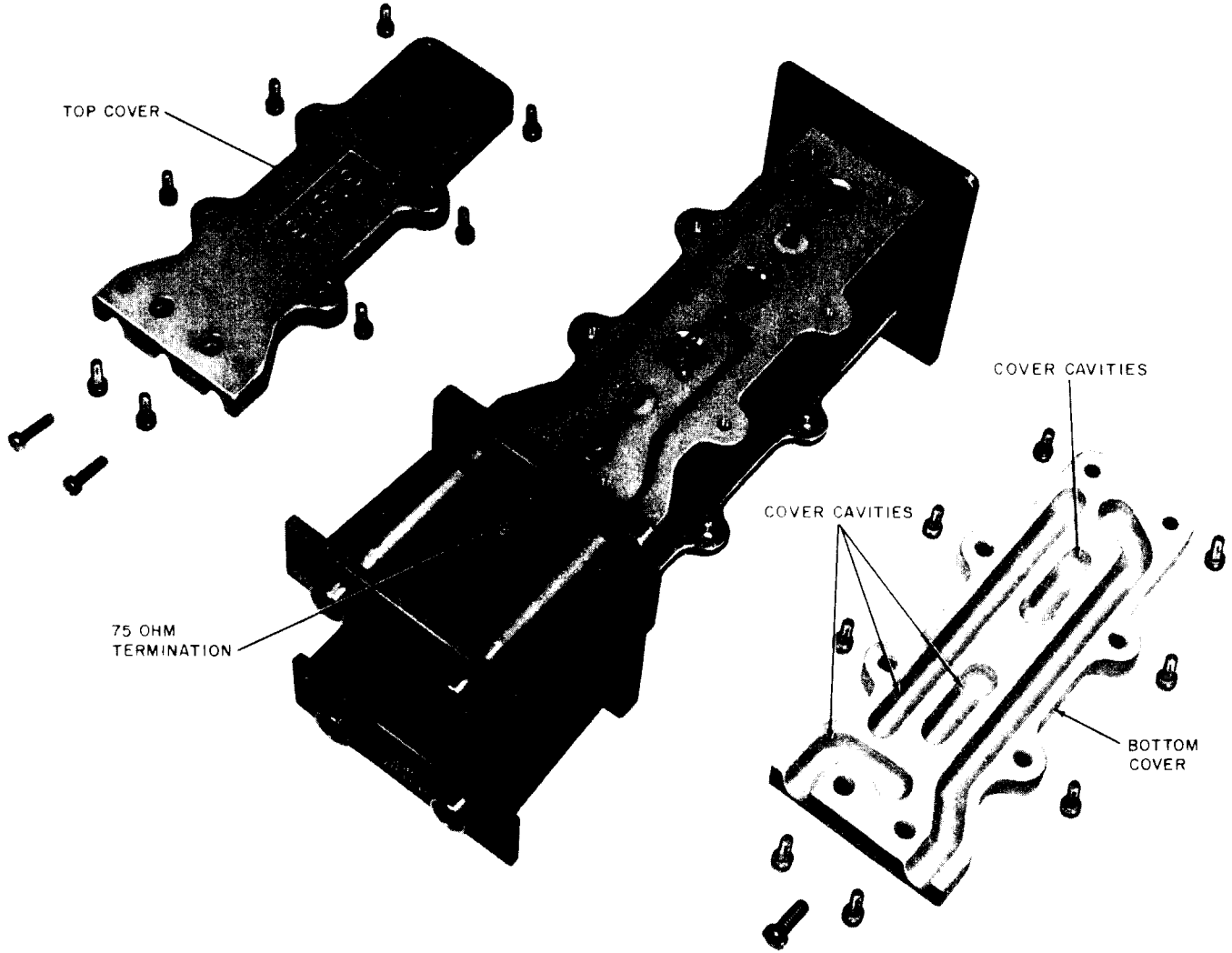

Fig. 2—223B Coaxial Switch, Disassembled, Top View

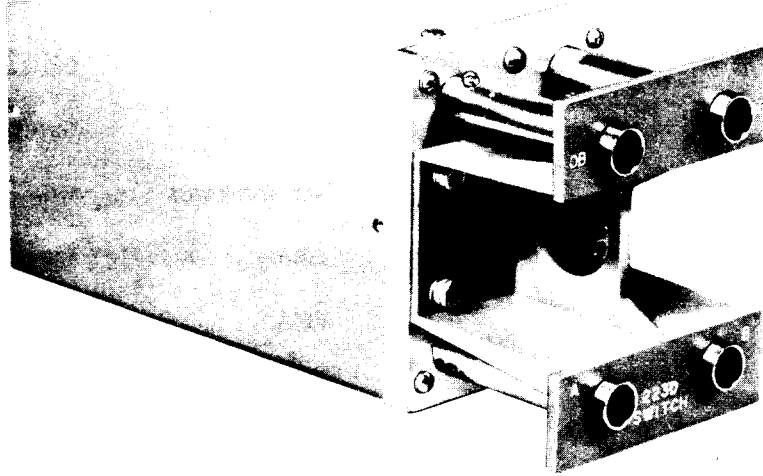

Fig. 3—223D Coaxial Switch, Assembled

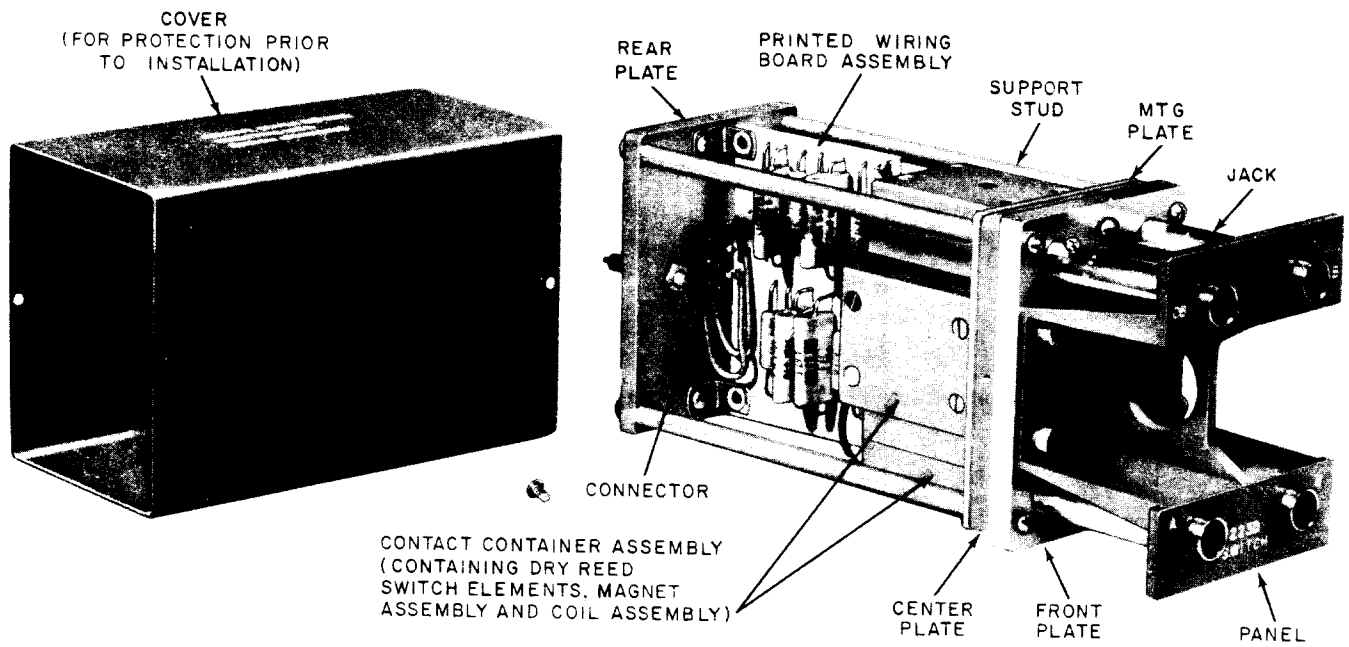

Fig. 4—223D Coaxial Switch, Cover Removed

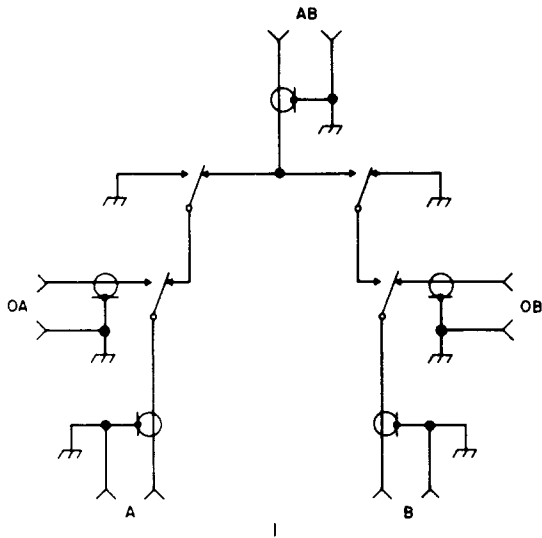

Fig. 5—223A Coaxial Switch Schematic (Shown in Normal Released Condition)

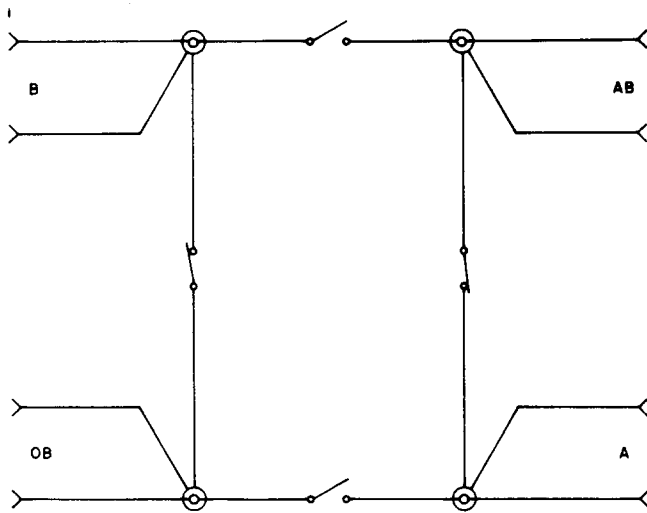

Fig. 6—223E Coaxial Switch Schematic (Shown in Normal Released Condition)

3. APPARATUS

3.01 List of Tools and Test Apparatus:

CODE OR SPEC NO.	DESCRIPTION
------------------	-------------

TOOLS

AT-7825	3-Inch C Screwdriver
KS-2993	Brush
—	◆Miscellaneous Hex Wrenches
—	Safety Goggles (Approved)◆

TEST APPARATUS

358A	Shorted Plug
368A	Plugs (3 Req'd)
J68333	Test Bench
J68340A	Test Bay
J68345A	Test Bay
KS-14510, L11	Volt-Ohm-Milliammeter
KS-16669	Timing Test Set
P2BT	Miscellaneous Patch Cords
P2CF	Cord
—	35-Type Relay Test Set
—	Power Cord per Fig. 7
—	Spare TD-2 IF Main Amplifier

4. SWITCH CLEANING

4.01 These cleaning procedures apply only to the 223A, 223B, and 223C switches identified by either a label or a screen-printed instruction message which reads "WARNING—WEAR SAFETY GLASSES WHEN DISASSEMBLING." Switches marked with the instructions "CAUTION—DO NOT DROP OR JAR" and "WARNING—DO NOT OPEN" should not be opened.

4.02 Failure of the switch to meet any of the test requirements specified may be due to the formation of metallic whiskers on the die-cast surfaces adjacent to the copper-inner conductors. Switches found to be malfunctioning as indicated by the tests might be restored to an operative condition by using a cleaning procedure that would remove whiskers which may be present.

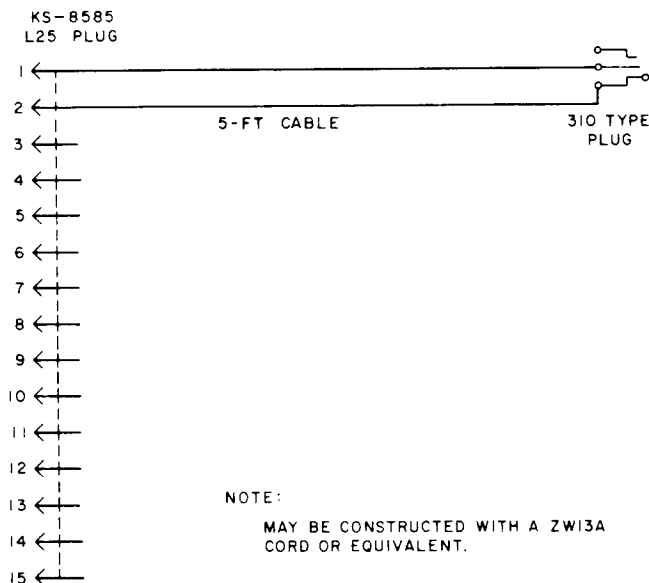

Fig. 7—Power Cable to Connect 35-Type Test Set to J68333 Test Bench

⚠Danger: Wear safety glasses while disassembling, cleaning, and reassembling the 223A, 223B, and 223C switches. The four glass-sealed mercury switching elements of these switches contain hydrogen at a pressure of 100 pounds per square inch.⚠

4.03 Metallic whiskers can be removed as follows:

- (1) Remove the top cover plate.
- (2) Either of the following two methods may be used to remove whiskers.
 - (a) Direct a blast of pressurized air (from air line or aerosol can) to cover cavities and mating main body areas for a few seconds. This method is preferred because it is fast and the most efficient.
 - (b) Using a clean, soft bristle brush, such as the KS-2993 brush, clean the cover cavities and the mating main body areas.
- (3) Replace the top cover and repeat the procedure on the bottom of the switch.

4.04 Switches that cannot be cleaned using this method may be considered defective and

should be returned in accordance with local instructions to the Western Electric Company.

4.05 A tag shall be attached to any returned switch with a brief statement regarding trouble experienced and whether or not there was any evidence of mercury present on the exterior of the switch at the time of removal from service. This, if present, is in the form of a black discoloration.

5. TEST REQUIREMENTS FOR 223A, 223B, AND 223C SWITCHES

5.01 These tests include operate and release current values, transmission, crosstalk, return loss, and switching time tests.

5.02 These tests are on an out-of-service basis.

5.03 If any requirements in the following tests cannot be met, the switch should be returned to the Western Electric Company on an Engineering Complaint Form E-5141 in accordance with local instructions.

5.04 Operate and Release Current Test:

- (a) Establish test circuit of Fig. 8.
- (b) For the 223A or B switch, set the 35-type test set as follows:
 - (1) Set resistance switches associated with key number 4 to 100,000 ohms (three right-hand toggle switches in top row).
 - (2) Close key 4 and adjust rheostat 4 for a current of 1.0 mA through the switch.
 - (3) Close key 3 and adjust rheostat 3 for a current of 5.5 mA.

This establishes the release and operate current values for the 223A and B switches. With key 4 closed for the remainder of the tests, closing or opening key 3 will operate or release the 223 switch.

(c) For the 223C switch, set the 35-type test set as follows:

- (1) Close key 4 and adjust rheostat 4 for 5 mA.

- (2) Close key 3 and adjust rheostat 3 for 20 mA.

This establishes the release and operate current values for the 223C switch. With key 4 closed for the remainder of the tests, closing or opening key 3 will operate or release the 223C switch.

- (d) Establish the test circuit of Fig. 9 (40A bay) or Fig. 10 (45A bay) and prepare for test.
- (e) Connect the test circuit to the 223 switch as shown by options V (jack A) and Z (jack AB). With the 223 switch released, the IF power meter should read approximately 0 dB.
- (f) Operate the switch by closing key 3 on the 35-type test set. The IF power meter reading should drop. Release and operate the switch several times to ensure that the contacts do not bridge permanently.
- (g) Change option V to jack B. With the 223 switch released, the IF power meter should show no reading.
- (h) Operate the switch. The IF power meter should read 0 dB. Operate and release the switch several times to ensure that the contacts do not bridge permanently.

5.05 Transmission Tests:

- (a) Change the test circuit of Fig. 9 or 10 to options X and Y.
- (b) **For 40A Test Bay (Fig. 9):**
- (1) Adjust the IF oscillator to 80 MHz.
- (2) Adjust IF detector No. 2 to 60 MHz.
- (3) Turn on sweep and adjust horizontal gain of scope to a scale of 10 MHz per inch by making the two IF meter pips 2 inches apart.
- (4) Adjust XTAL 1 to make the test and reference traces coincide at 70 MHz.
- (5) Increase the setting of attenuator AT11 by 1 dB.

- (6) Adjust the vertical gain of the scope to a scale of 1 dB per inch by making the separation of the traces equal to 1 inch.

- (7) Decrease the attenuator setting in Step (5) 1 dB to its previous value. The traces should coincide at 70 MHz within ± 0.05 inch. If not, repeat Steps (4) thru (7).

- (8) Because of the close limits which must be met by the gain-frequency characteristics, the test trace must match the reference trace as close as possible before the amplifier is connected into the circuit.

Requirement: When the highest point of the test trace coincides with the reference trace, no point on the test trace should be below the reference trace by more than 0.05 dB between 60 and 80 MHz.

- (9) If this requirement is not met, the test and reference circuits should be examined and made as nearly alike as possible. For example, lengths of patch cord should be changed and the effect of the slope of the traces noted. Minor rearrangements are ordinarily adequate to meet the requirement.

- (10) Change the circuit of Fig. 9 (40A bay) or Fig. 10 (45A bay) to option V (jack A) and option W (jack AB). Terminate all unused jacks on the 223 switch with 368A plugs.

Requirement: With the 223 switch released, no point on the test trace should be more than 0.2 dB below the reference trace.

- (11) Change option V to jack B and option W to jack OB.

Requirement: With the 223 switch released, no point on the test trace should be more than 0.15 dB below the reference trace.

- (12) Change option W to jack AB and operate the 223 switch.

Requirement: No point on the test trace should be more than 0.2 dB below the reference trace.

(13) For the 223A or C switch, change option V to jack A and option W to jack OA. Operate the switch.

Requirement: No point on the test trace should be more than 0.15 dB below the reference trace.

(14) For the 223B switch, set the KS-14510 volt-ohm-milliammeter to read ohms. Connect the meter to the center conductor and shell of jack A. Operate the switch.

Requirement: 70 to 80 ohms.

(c) **For 45A Test Bay (Fig. 10):**

(1) Adjust M1 to 80 MHz and M2 to 60 MHz.

(2) Adjust the sweep to maximum and adjust horizontal gain of scope to a scale of 10 MHz per main division by making the two IF meter pips two main divisions apart.

(3) Adjust INPUT 1 to make the test and reference traces coincide at 70 MHz.

Note: If necessary, reverse SW IN 1 and SW IN 2 cords due to slight difference in their lengths. See Step (8).

(4) Increase the setting of attenuator AT12 by 1 dB.

(5) Adjust the vertical gain of the scope to a scale of 1 dB per inch by making the separation of the traces equal to 1 inch.

(6) Decrease the attenuator setting in Step (4) 1 dB to its previous value. The traces should coincide at 70 MHz within 0.05 inch. If not, repeat Steps (3) through (6).

(7) Because of the close limits which must be met by the gain-frequency characteristics, the test trace must match the reference trace as closely as possible before the amplifier is connected into the circuit.

Requirement: When the highest point of the test trace coincides with the reference trace, no point on the test trace should be below the reference trace by more than 0.05 dB between 60 and 80 MHz.

(8) If this requirement is not met, the test and reference circuits should be examined and made as nearly alike as possible. For example, lengths of patch cord should be changed and the effect of the slope of the traces noted. Minor rearrangements are ordinarily adequate to meet the requirement.

(9) Change the circuit of Fig. 9 (40A bay) or Fig. 10 (45A bay) to option V (jack A) and option W (jack AB). Terminate all unused jacks on the 223 switch with 368A plugs.

Requirement: With the 223 switch released, no point on the test trace should be more than 0.2 dB below the reference trace.

(10) Change option V to jack B and option W to jack OB.

Requirement: With the 223 switch released, no point on the test trace should be more than 0.15 dB below the reference trace.

(11) Change option W to jack AB and operate the 223 switch.

Requirement: No point on the test trace should be more than 0.2 dB below the reference trace.

(12) For the 223A or C switch, change option V to jack A and option W to jack OA. Operate the switch.

Requirement: No point on the test trace should be more than 0.15 dB below the reference trace.

(13) For the 223B switch, set the KS-14510 volt-ohm-milliammeter to read ohms. Connect the meter to the center conductor and shell of jack A. Operate the switch.

Requirement: 70 to 80 ohms.

5.06 IF Return Loss Tests:

(a) Prepare the test equipment and the test bench for tests as shown in Fig. 11 and 12.

(b) **For 40A Test Bay (Fig. 11):**

- (1) Adjust AT11 to read +3.0 dBm on IF power meter.
- (2) Adjust AT12 to same value as AT11.
- (3) Change from (X) to (Y) option.
- (4) Adjust the IF oscillator to 80 MHz and adjust IF detector No. 2 to 60 MHz.
- (5) Turn on sweep and adjust horizontal gain of scope to a scale of 10 MHz per inch by making the two IF meter pips 2 inches apart.
- (6) Set attenuators AT13 and AT14 for a loss totaling 38 dB.
- (7) Turn on the slope.
- (8) Adjust the gain of the amplifier, the slope, and XTAL 1, for coincidence of test and reference traces producing a scope picture similar to Fig. 13B.

Note: This condition, including the attenuation of 38 dB, obtained in Step (6), constitutes a calibration for reference in adjusting impedance. Reflection from the open end of branch C of IF DC should be practically complete.

- (9) Adjust the vertical gain of the scope to 1 dB per inch by noting the change in position of the test trace when attenuator AT11 is decreased by 1 dB and increased again 1 dB.
- (10) Terminate branch C of IF DC with a 486A jack. Reduce the attenuators AT13 and AT14 to zero.

Requirement: The test trace should remain below the reference trace between 60 and 80 MHz.

- (11) If this requirement is not met, either IF DC or one of the 486A jacks is defective. This condition must be cleared before proceeding with the test.
- (12) Remove the 486A jack from branch C of IF DC.

- (13) Connect branch C to jack A of the 223 switch. With all unused jacks of the 223 switch terminated with 368A plugs, the test trace should remain below the reference trace for both operated and released condition of switch. (>38 dB return loss.)

- (14) Repeat Step (13) with branch C connected to jack B.

(c) **For 45A Test Bay (Fig. 12):**

- (1) Adjust AT13 to read +3.0 dBm on MTR IF.
- (2) Adjust AT11 to same value as AT13.
- (3) Change from (X) to (Y) option.
- (4) Adjust IF meters M1 to 80 MHz and M2 to 60 MHz.
- (5) Turn the sweep to maximum and adjust horizontal gain of scope to a scale of 10 MHz per main division by making the two IF meter pips two main divisions apart.
- (6) Set attenuators AT12 and AT14 for a loss totaling 38 dB.
- (7) Turn on the slope.
- (8) Adjust the gain of the amplifier, the slope, and input 1, for coincidence of test and reference traces producing a scope picture similar to Fig. 13B.

Note: This condition, including the attenuation of 38 dB, obtained in Step (6), constitutes a calibration for reference in adjusting impedance. Reflection from the open end of branch C of IF DC should be practically complete.

- (9) Adjust the vertical gain of the scope to 1 dB per inch by noting the change in position of the test trace when attenuator AT12 is decreased by 1 dB and increased again 1 dB.
- (10) Terminate branch C of IF DC with a 486A jack. Reduce attenuators AT12 and AT14 to zero.

Requirement: The test trace should remain below the reference trace between 60 and 80 MHz.

- (11) If this requirement is not met, either IF DC or one of the 486A jacks is defective. This condition must be cleared before proceeding with the test.
- (12) Remove the 486A jack from branch C of IF DC.
- (13) Connect branch C to jack A of the 223 switch. With all unused jacks of the 223 switch terminated with 368A plugs, the test trace should remain below the reference trace for both operated and released condition of switch. (>38 dB return loss.)
- (14) Repeat Step (13) with branch C connected to jack B.

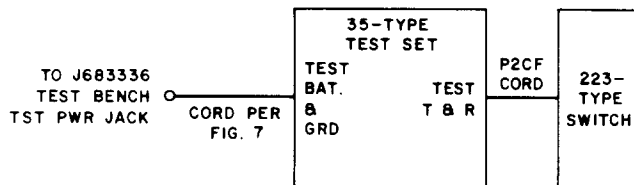

35-TYPE TEST SET
PREPARATION FOR TEST

1. SET ALL RHEOSTAT SLIDERS FOR MAXIMUM RESISTANCE (EXTREME RIGHT).
2. OPEN ALL KEY SWITCHES.
3. G SWITCH TO OPEN. BAT. & GRD CO LEVER SWITCH NORMAL. REV LEVER SWITCH NORMAL. VM SWITCH NORMAL (TO READ CURRENT). ALL RESISTANCE SWITCHES TO 0.
4. ESTABLISH TEST CIRCUIT.

Fig. 8—Test Arrangements to Operate 223-Type Switch

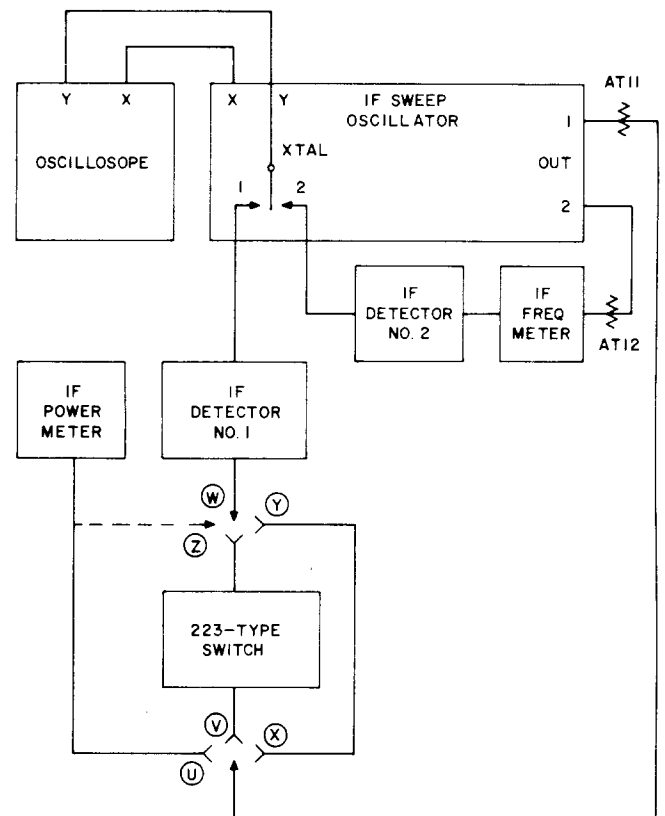

40 A TEST BAY
PREPARATION FOR TEST

1. OPERATE SWEEP AND SLOPE CONTROLS TO OFF.
2. SET OSCILLATOR TO 70 MHZ.
3. CONNECT CIRCUIT PER OPTION U.
4. ADJUST AT11 TO GIVE A READING OF 0 DBM ON THE IF POWER METER.
5. SET AT12 TO THE SAME VALUE AS AT11.

NOTE:
IF DETECTOR NO. 1 SHOULD BE THE PORTABLE ONE.

Fig. 9—Arrangement for Transmission Test of 223-Type Switches Using 40A Test Bay

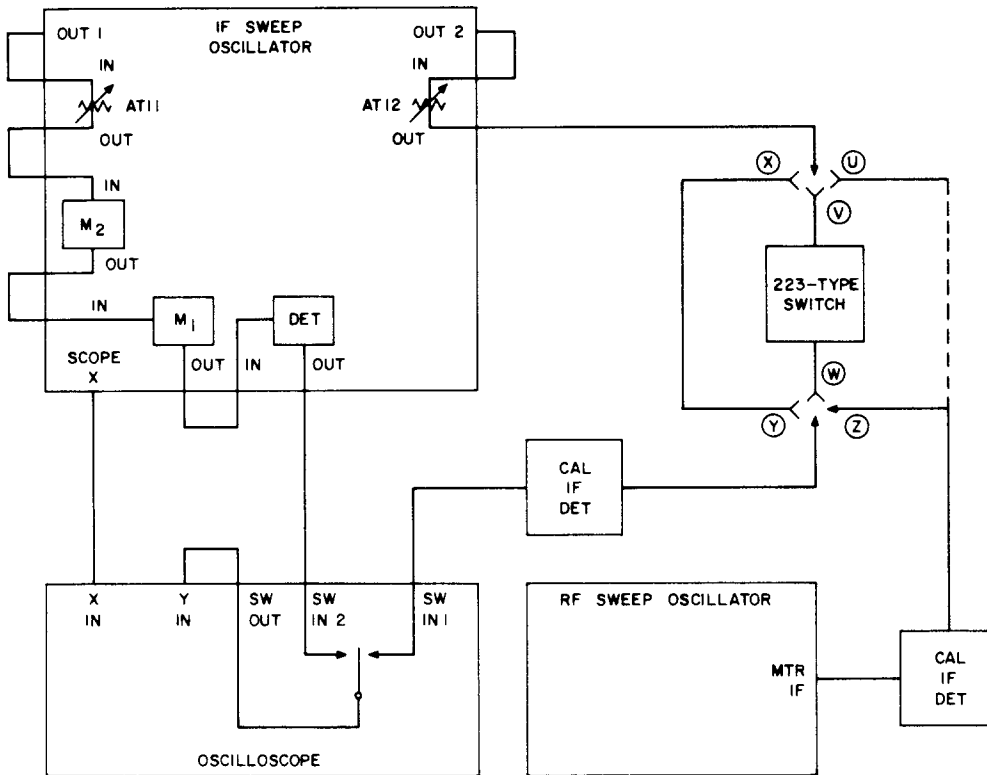

45A TEST BAY
PREPARATION FOR TEST

1. OPERATE SWEEP AND SLOPE CONTROLS TO OFF
2. CONNECT CIRCUIT PER OPTION U.
3. ADJUST AT12 TO GIVE A READING OF 0 DB ON THE IF POWER METER.
4. SET AT11 TO THE SAME VALUE AS AT12.

Fig. 10—Arrangement for Transmission Test of 223-Type Switches Using 45A Test Bay

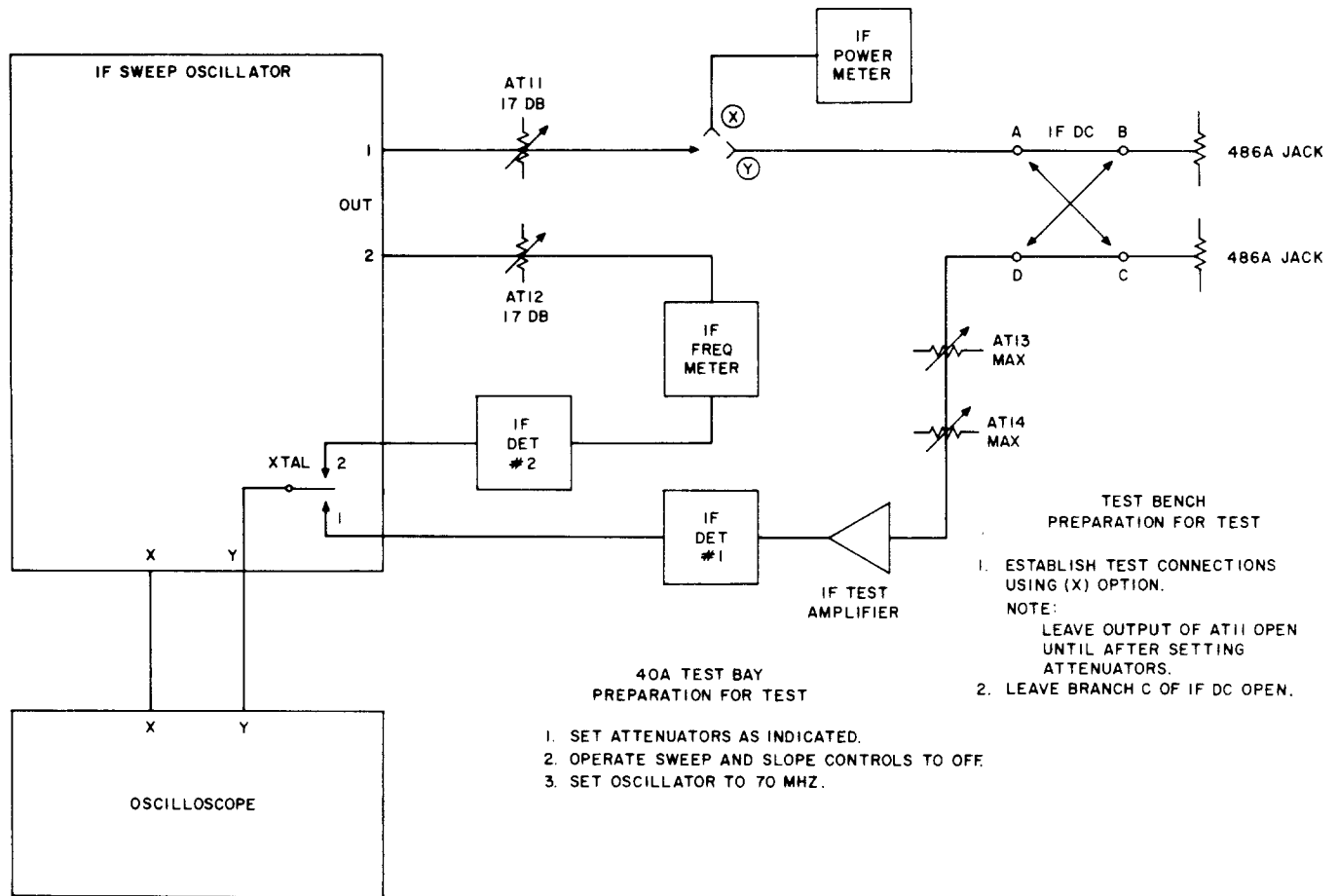

Fig. 11—Test Arrangement for Return Loss Measurement of the 223-Type Switch Using 40A Test Bay

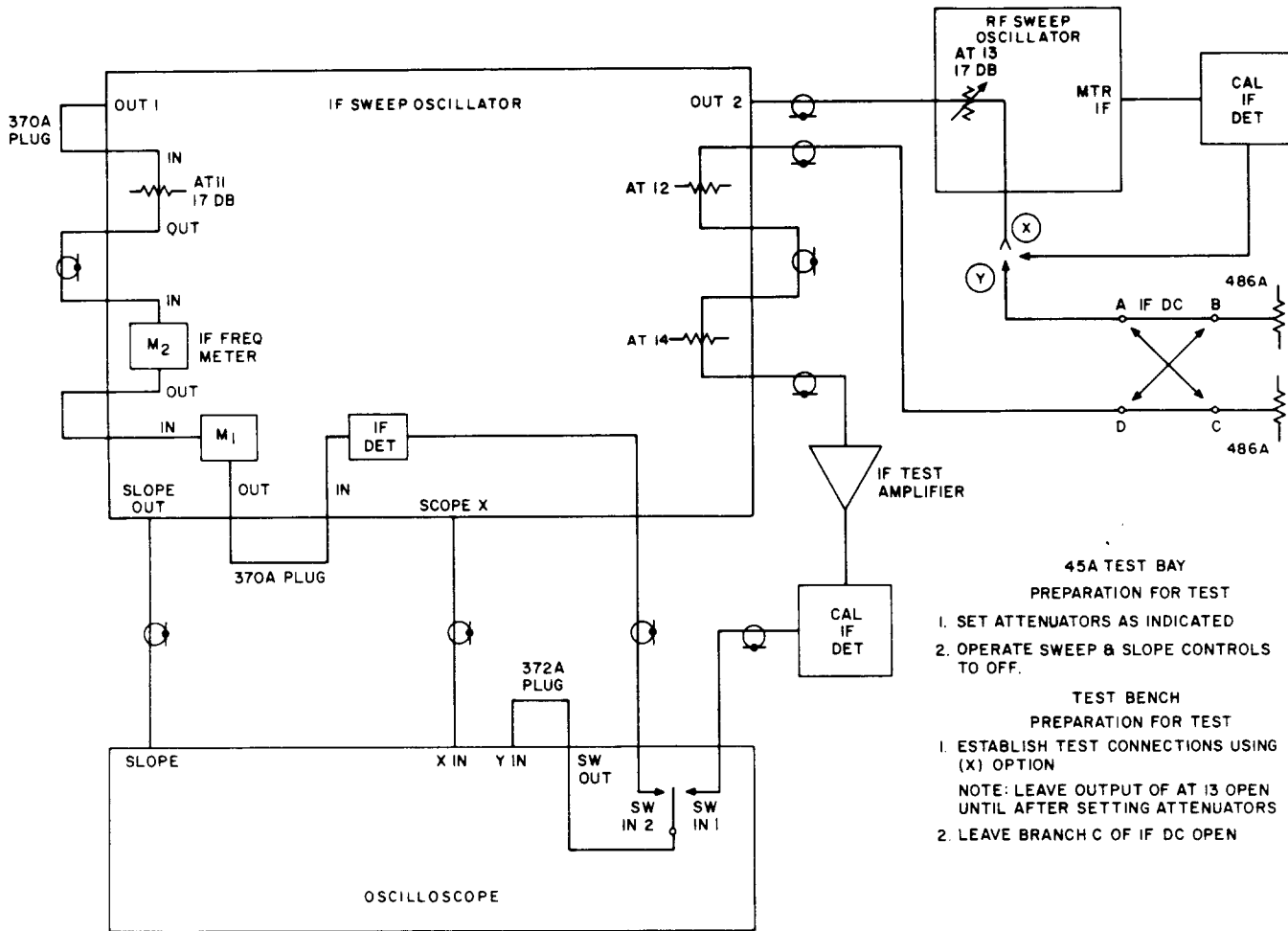
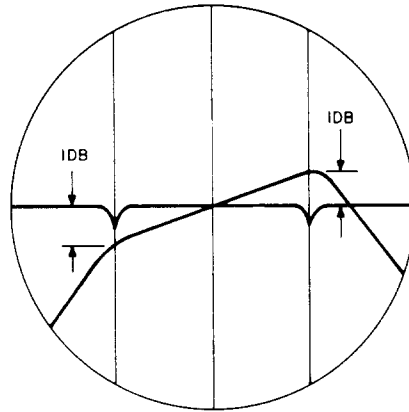
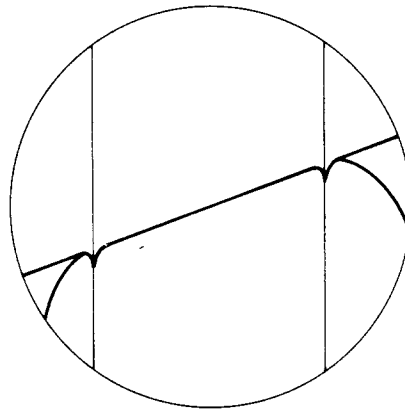

Fig. 12—Test Arrangement for Return Loss Measurement of the 223-Type Switch Using 45A Test Bay



A. NO TERMINATION
SLOPE CKT OFF



B. NO TERMINATION SLOPE CKT
ON REF TRACE ADJUSTED
TO MATCH TEST TRACE

Fig. 13—Oscilloscope Trace Appearance for Return Loss Setup

5.07 Crosstalk Tests:

(a) Establish the circuit of Fig. 14 or 15, option U.

(b) Adjust the following attenuators for a reading of 0 dBm on the IF power meter:

40A TEST BAY (Fig. 14)

45A TEST BAY (Fig. 15)

AT11

AT12

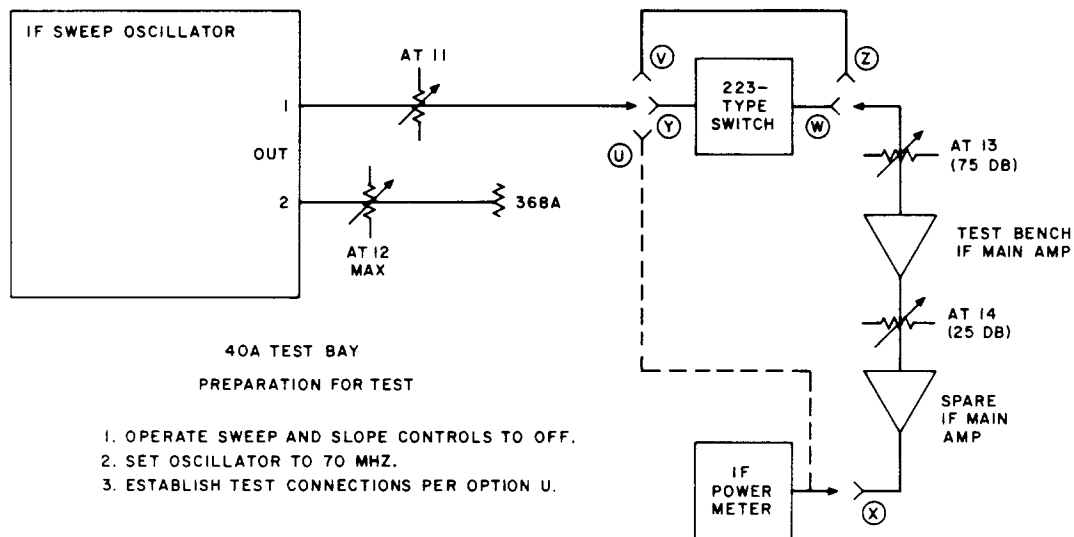

Fig. 14—Arrangement for Crosstalk Test Using 40A Test Bay

- (c) Change to options V, Z, and X.
- (d) Set AT13 and AT14 to a total of 100 dB.
- (e) Adjust IF-gain and MAN-gain controls on test bench for a reading of 0 dB on the IF power meter.
- (f) Reduce AT14 3 dB. The IF power meter reading should increase 3 dB. If it does

not, test the IF amplifiers per Section 410-724-500 before continuing the crosstalk test.

- (g) With the 223 switch released, connect the test circuit per options Y, W, and X. Reduce AT13 and AT14 to obtain a reading of 0 dB on the IF power meter. Determine the crosstalk loss as $100 - (AT13 + AT14)$.

45A TEST BAY

PREPARATION FOR TEST

- 1. OPERATE SLOPE AND SWEEP CONTROLS TO OFF
- 2. ESTABLISH TEST CONNECTIONS PER OPTION U.

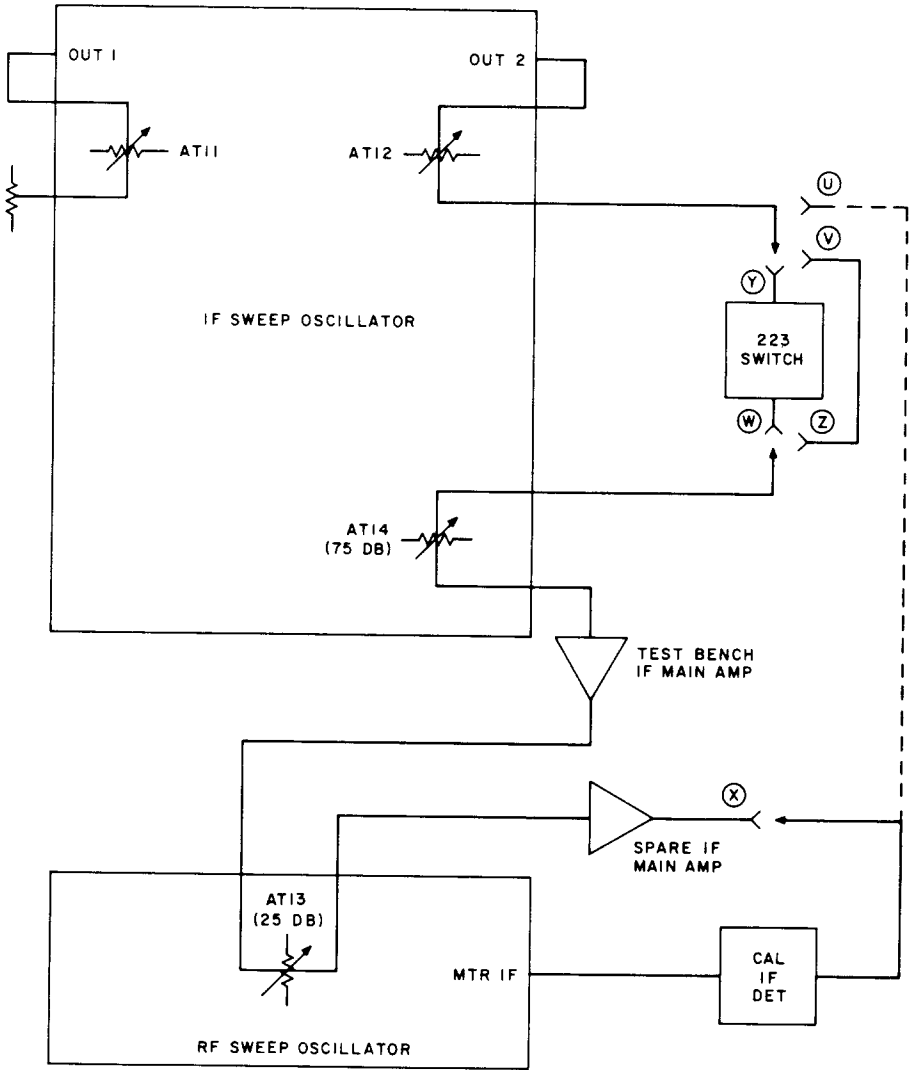

Fig. 15—Arrangement for Crosstalk Test Using 45A Test Bay

TABLE A
CROSSTALK TEST REQUIREMENTS

SWITCH CONDITION	TYPE PLUG	PATH	TERMINATIONS (SEE NOTE 1)	CROSSTALK LOSS
Released	223A & C 223B	B to AB B to AB	A, OA, OB A, OB	90 dB Min 90 dB Min
Operated	223A & C 223B	A to AB A to AB	B, OA, OB B, OB	90 dB Min 90 dB Min

Requirements per Table A:

(h) Repeat Step (g) for the switch operated, using Table A.

5.08 Operating Time Tests:

Note: These tests apply only to 223A and B switches.

(a) **Break Contact Test:**

(1) Set up the test circuit as shown in Fig. 16A.

(2) Set the controls of the KS-16669, L1, timing test set as follows:

CONTROL	POSITION
AUTO-TIME	Full clockwise
SLOPE	—
LEVEL	Midway between + and —

(3) Operate the AUTO-OP switch of the KS-16669 timing test set. The test set will register directly in tenths of milliseconds, the time required for the 223 switch to operate.

(4) Repeat Step (3) ten times allowing at least 10 seconds to elapse between operations.

(5) Divide the time registered on the test set by 10 and record.

(6) Operate the RESET button on the test set.

Requirement: The operate time shall not be more than 2 ms.

(b) **Make Contact Test:**

(1) Set up the test circuit as shown in Fig. 16B.

(2) Set the controls of the KS-16669, L1, timing test set as follows:

CONTROL	POSITION
AUTO-TIME	Full clockwise
SLOPE	—
LEVEL	Midway between + and —

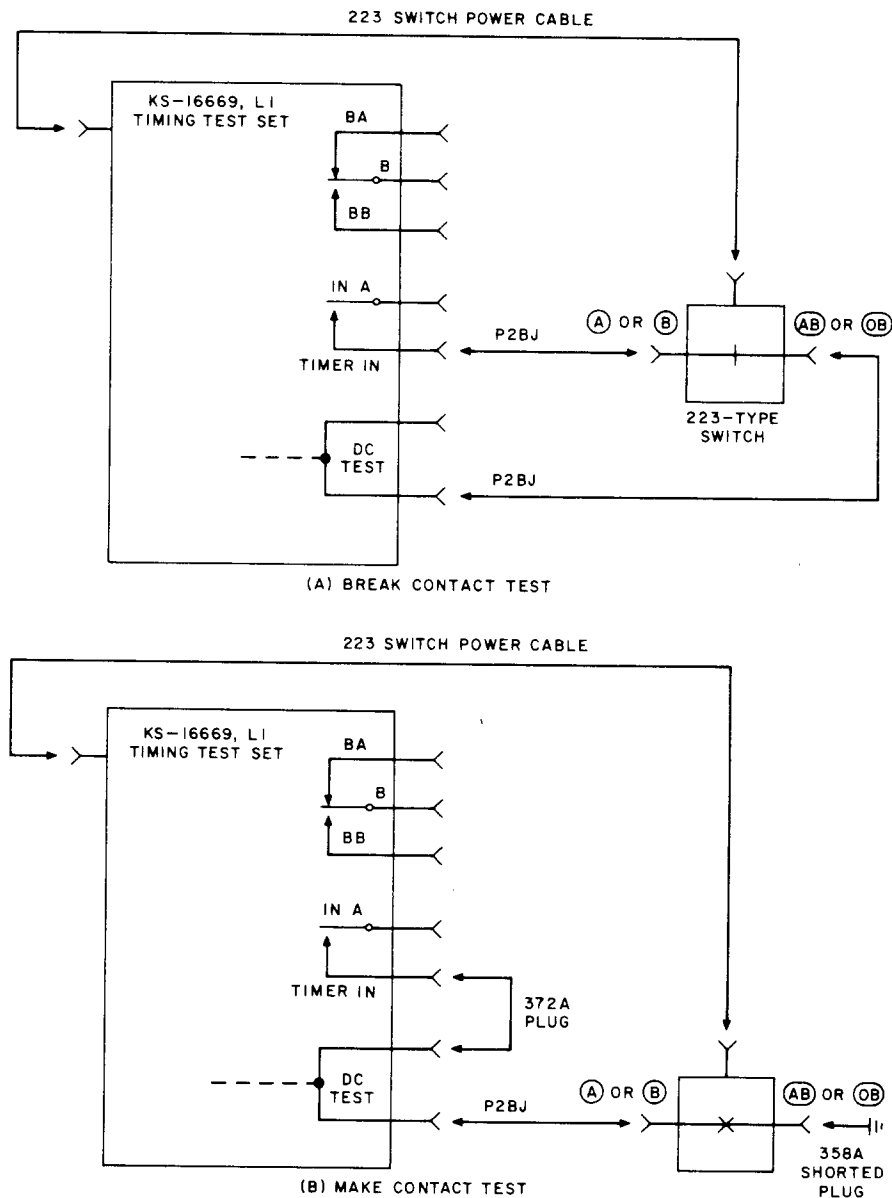

Fig. 16—Test Arrangement for 223-Type Switch Timing Tests

- (3) Operate the AUTO-OP switch of the KS-16669 timing test set. The test set will register directly in tenths of milliseconds, the time required for the 223 switch to operate.
- (4) Repeat Step (3) ten times allowing at least 10 seconds to elapse between operations.
- (5) Divide the time registered on the test set by 10 and record.

- (6) Operate the RESET button on the test set.

Requirement: The operate time shall not be more than 2 ms.

6. TEST REQUIREMENTS FOR 223D AND 223E SWITCHES

6.01 Adjustment of Block Magnets:

- (a) After assembly, block P-44N102 or P-44N103 shall be magnetized to saturation. The S

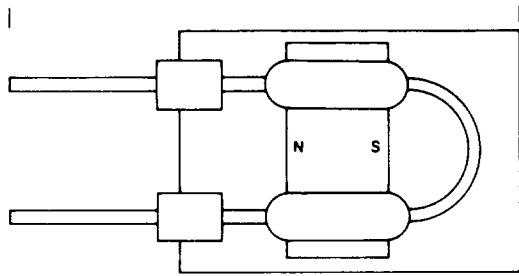

Fig. 17—Block Magnets

pole (Fig. 17) shall attract the north-seeking pole of a magnetic compass.

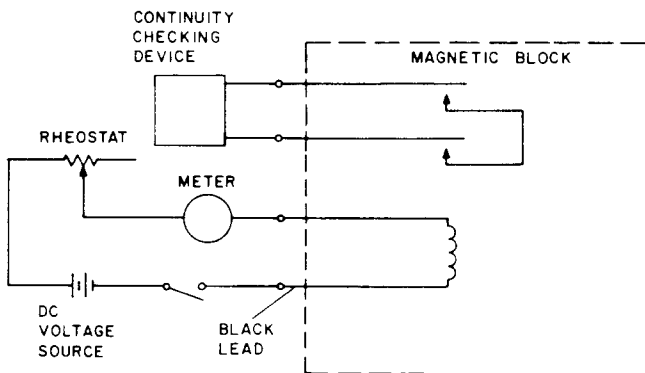

Fig. 18—Indicating Circuit

(b) Using the indicating circuit (Fig. 18), or its equivalent, each block, P-44N102 or P-44N103, shall be demagnetized until both switch elements (combined) open at 6 ± 1.5 mA and close at ≥ 1 mA but < 4.5 mA.

(c) Using the indicating circuit (Fig. 18), verify that each block, P-44N100, or 101 switch elements close between 5 and 7 mA and open at 2.4 ± 0.5 mA.

6.02 Insertion and Isolation Loss Tests:

(a) Insertion loss is the loss when a path is completed. Isolation loss is the loss across the path when the contact is open.

(b) Measurements will be made, with equipment as per Section 356-010-500, at 8 MHz and 0 dBm power level.

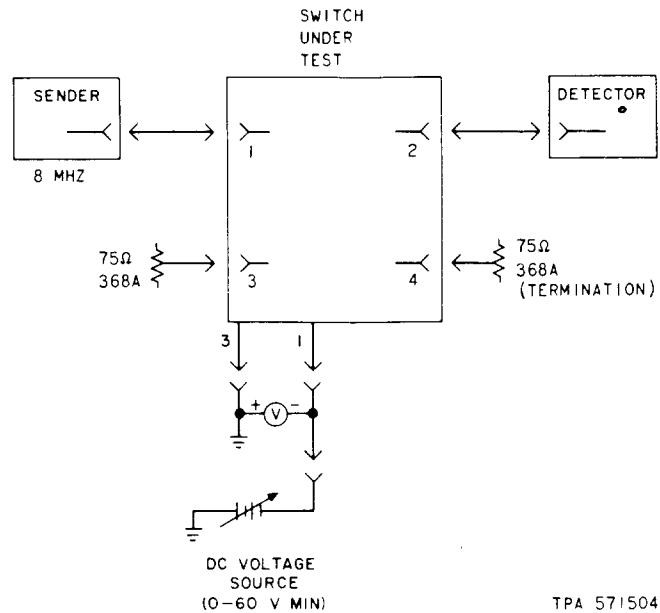

Fig. 19—Insertion and Isolation Loss/Test Circuit

(c) Connect test circuits input to output (Fig. 19). Adjust sender's output level for 0 dBm. Calibrate detector to this level. This process will eliminate test circuit losses. The detector should now indicate a true insertion loss reading.

(d) Insert a 223D (223E) switch into the test circuit of Fig. 19, referring to Test 1 of Table B for proper input and output connections, measurements, and type of measurement. Terminate each unused jack with a 368A termination (two required).

(e) Repeat Step (c) for Tests 2, 3, and 4 for 223D switch; Tests 2, 5, and 6 for 223E switch.

6.03 Return Loss Measurements:

(a) Return loss tests are used to determine that the impedance of unit is within specified range at the jack under test.

(b) Referring to the test circuit of Fig. 20, with transformer jacks 1 and 2 open circuited, adjust sender's output level for a detector level indication of -10 dB.

(c) Terminate transformer jack 1 in 75, connect switch according to Test 1 of Table C, record

TABLE B

INSERTION AND ISOLATION LOSS DATA (SEE NOTE.)

TEST NO.	VOLTAGE DC	PATH		PATH LOSS	TYPE SWITCH	TYPE LOSS
		1-2	1-2			
1	0	A-AB	B-OB	≤ 0.2 dB	223D & E	Insertion
2	0	A-OB	B-AB	≥ 90 dB	223D & E	Isolation
3	57	A-AB	B-OB	≥ 90 dB	223D	Isolation
4	57	A-OB	B-AB	≤ 0.2 dB	223D	Insertion
5	22	A-AB	B-OB	≥ 90 dB	223E	Isolation
6	22	A-OB	B-AB	≤ 0.2 dB	223E	Insertion

Note: Switches with a red designation near the pull hole on the front panel shall meet an insertion loss requirement of 0.3 dB MAX.

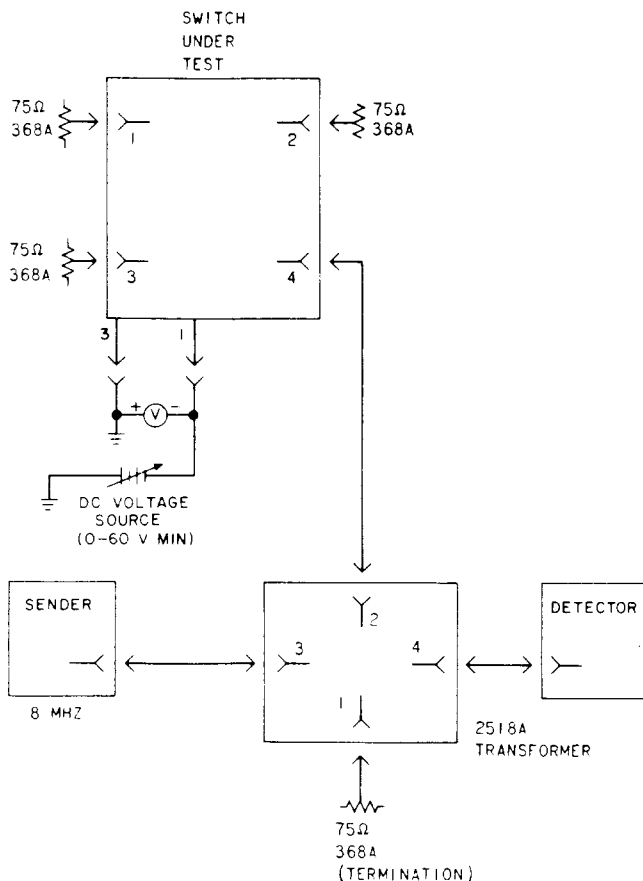

Fig. 20—Return Loss Test Circuit

detector level reading, subtract 10 dB (first reading) from this reading. Loss should now be equal to or greater than 35 dB.

(d) Repeat Steps (c) and (b) if necessary as follows:

Tests 2, 3, and 4 for 223D switch

Tests 2, 5, and 6 for 223E switch

6.04 Bridging time checks are used to determine that the switch is a make-before-break operation. The bridging time can be determined as follows:

(a) Establish test circuit of Fig. 21.

(b) Adjust the oscilloscope to trigger externally when switch (S1) is operated ON and OFF.

(c) Set the oscilloscope controls as follows:

(1) Screen selector—FULL

(2) Automatic erase—OFF

(3) Horizontal—0.5 ms/cm

(4) Vertical input—0.05 volts/cm

TABLE C

RETURN LOSS DATA (SEE NOTE.)

TEST NO.	VOLTAGE DC	MEASURE AT JACK	TERMINATE JACKS	RETURN LOSS	TYPE SWITCH
1	0	A	B, AB, OB	≥ 35 dB	223D & E
2	0	B	A, OB, AB	≥ 35 dB	223D & E
3	57	A	B, OB, AB	≥ 35 dB	223D
4	57	B	A, AB, OB	≥ 35 dB	223D
5	22	A	B, OB, AB	≥ 35 dB	223E
6	22	B	A, AB, OB	≥ 35 dB	223E

Note: Switches with a red designation near the pull hole on the front panel shall meet a return loss requirement of 34 dB MIN.

(5) Operate screen voltage to STORE.

(f) Operate screen voltage to STORE.

(d) Operate S1 to ON.

(g) Operate S1 to OFF.

Requirement: See Fig. 22—Timing Chart S1 to ON.

Requirement: See Fig. 23—Timing Chart S1 to OFF.

- Contact bounce A shall be less than 50 percent of B.
- Time T shall be less than 4.5 ms.

- Contact bounce A shall be less than 50 percent of B.

(e) Operate screen voltage to ERASE.

- Time T shall be less than 4.5 ms.

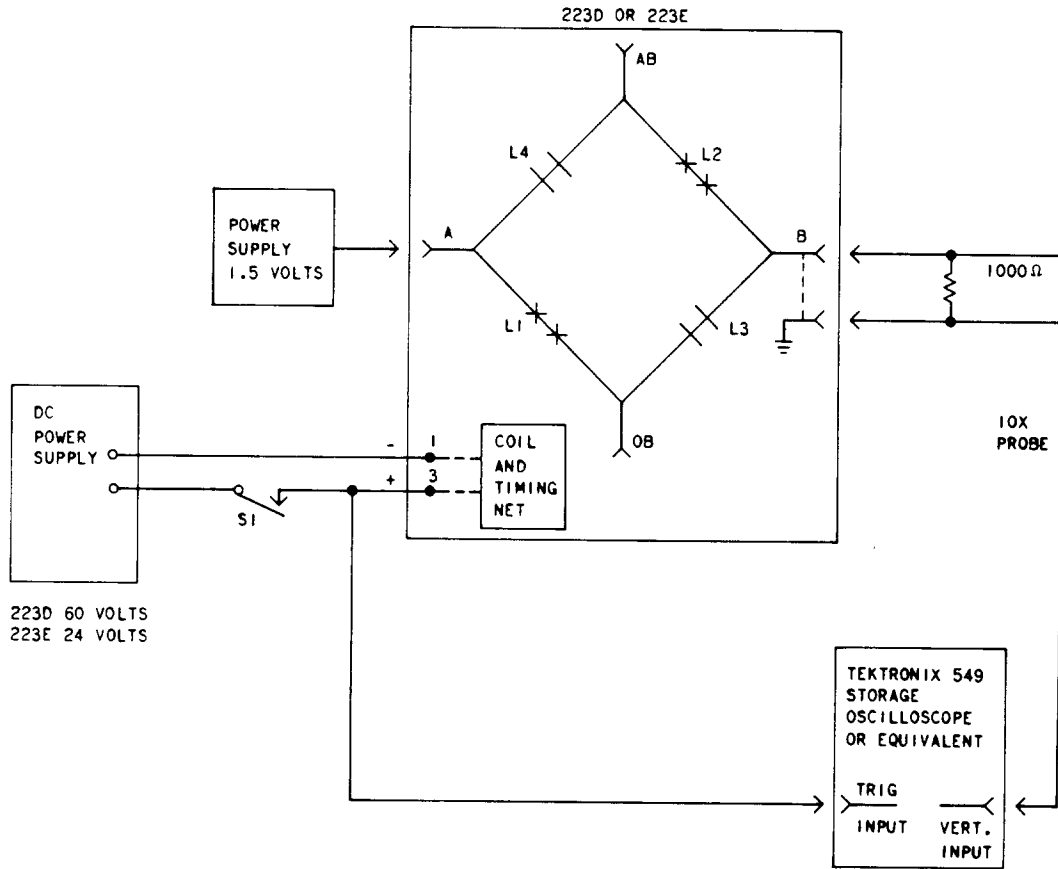

Fig. 21—Bridging Time Check Test Circuit

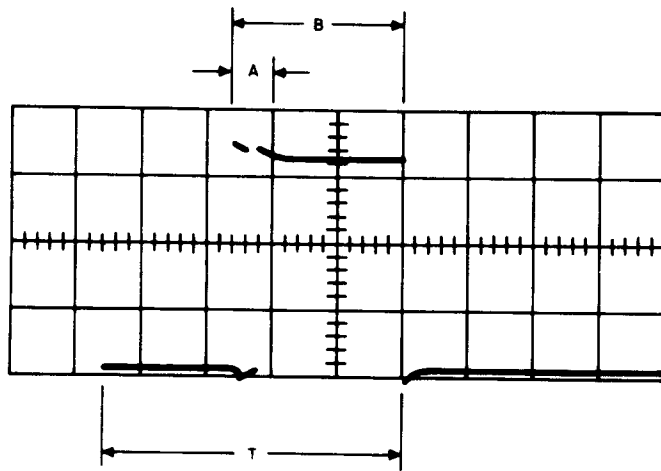

Fig. 22—Timing Chart (S1 to ON)

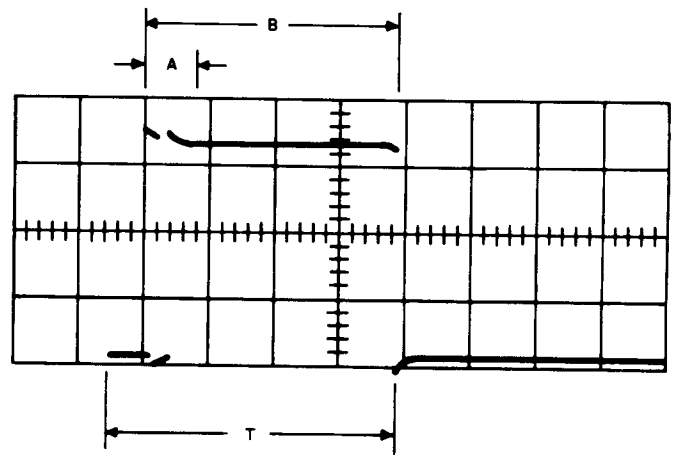

Fig. 23—Timing Chart (S1 to OFF)