

**KS-5189, KS-5189-01, KS-5189-02, AND KS-5189-03
EMERGENCY LIGHTING RELAY SWITCHES
PIECE-PART DATA AND REPLACEMENT PROCEDURES**

CONTENTS	PAGE
1. GENERAL	1
2. APPARATUS	1
3. REPLACEMENT PARTS	7
4. REPLACEMENT PROCEDURES	7
 Figures	
1. Emergency Lighting Relay Switch for 3-Phase Service (Without Cabinet, Old Version)	2
2. Emergency Lighting Relay Switch for 3-Phase Service (New Version)	3
3. Undervoltage Relay (Old Version)	4
4. Main Contacts (Old Version)	5
5. Undervoltage Device and Contactor Mechanism (Main Contact Open, Old Version)	6
6. Side View of the KS-5189-03 (New Version)	8
7. 920-Type Contactor (New Version)	9
8. Undervoltage Device and Contactor Mechanism (Main Contacts Closed, Old Version)	10

1. GENERAL

1.01 This section covers the emergency lighting relay switch per specifications KS-5189, KS-5189-01, KS-5189-02, and KS-5189-03. After replacing any parts, reference should be made to Section 030-742-701 which covers Requirements and Adjusting Procedures for the readjustment of parts affected by the replacement.

1.02 This section is reissued to add the new design of the KS-5189-03 emergency lighting relay switch.

Revision arrows are used to indicate significant changes. The Equipment Test List is not affected.

1.03 Part 3 of this section covers the methods of ordering the various parts and includes illustrative figures.

1.04 Part 4 of this section covers the approved procedures for the replacement of the parts.

2. APPARATUS

2.01 List of Tools and Materials

CODE OR SPEC NO.	DESCRIPTION
TOOLS	
206 or 207	Offset Screwdriver
417A	1/4-inch and 3/8-inch Hex Open Double-End Flat Wrench
R-8210	Screwdriver
AT-7825	4-inch E Screwdriver
AT-7858	5-inch B Diagonal Pliers
MATERIALS	
—	Friction Tape
—	Metal Pin, 1/4 inch diameter by 1-5/16 to 1-7/16 inches long (required for replacing the closing coil or the contactor mechanism)

NOTICE

Not for use or disclosure outside the Bell System except under written agreement

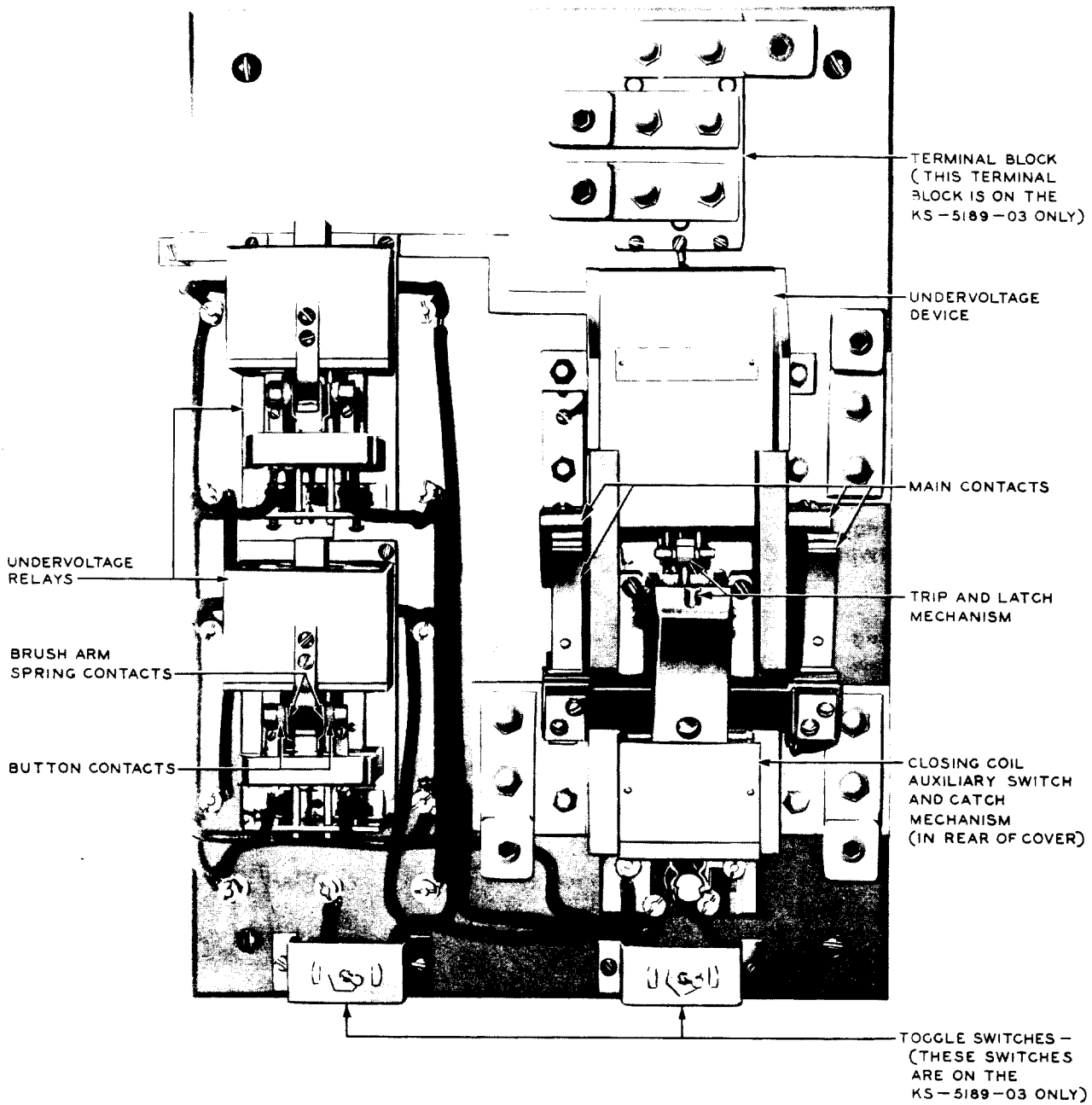

Fig. 1—Emergency Lighting Relay Switch for 3-Phase Service (Without Cabinet, Old Version)

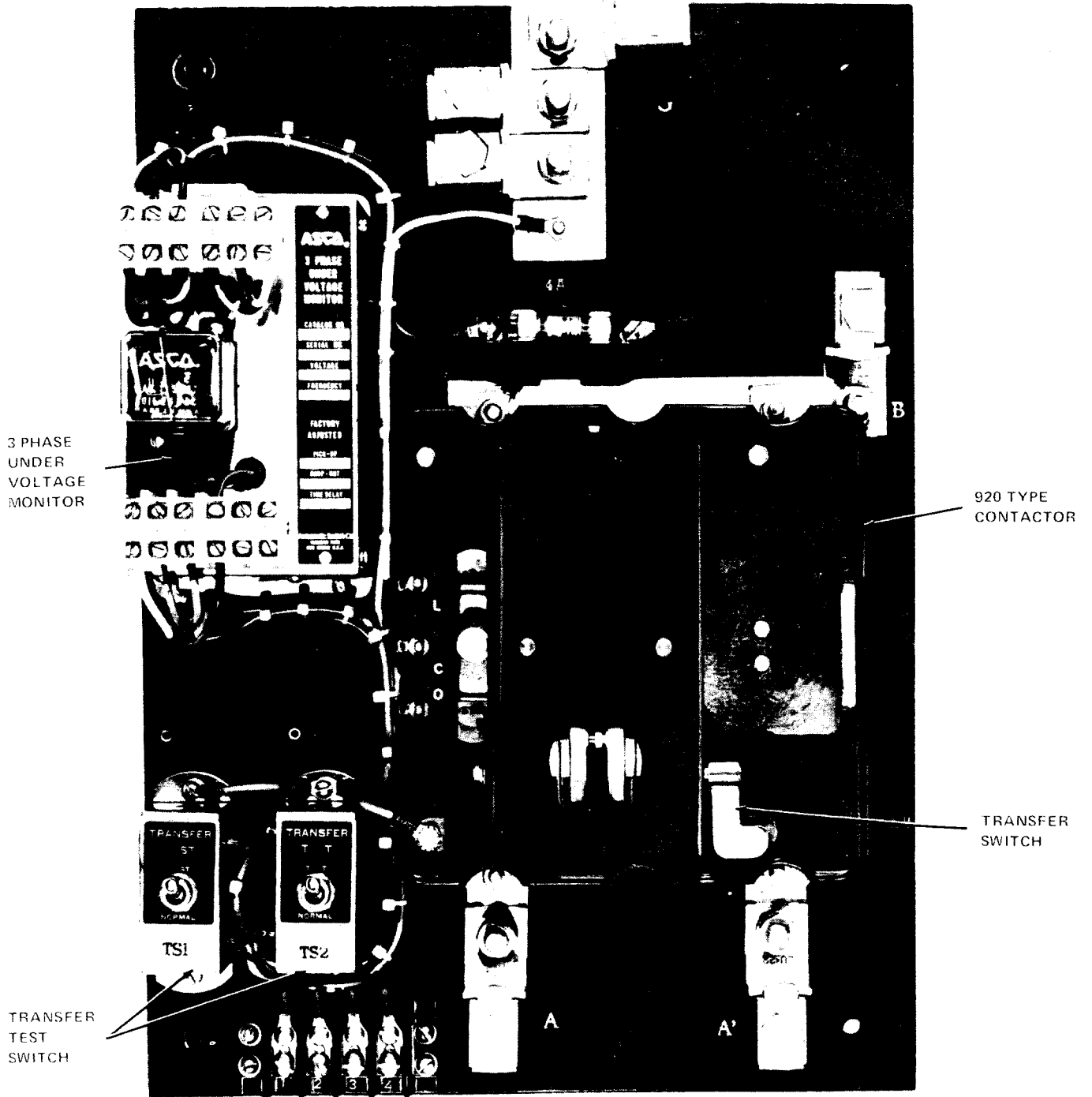

Fig. 2—Emergency Lighting Relay Switch for 3-Phase Service (Without Cabinet, New Version)

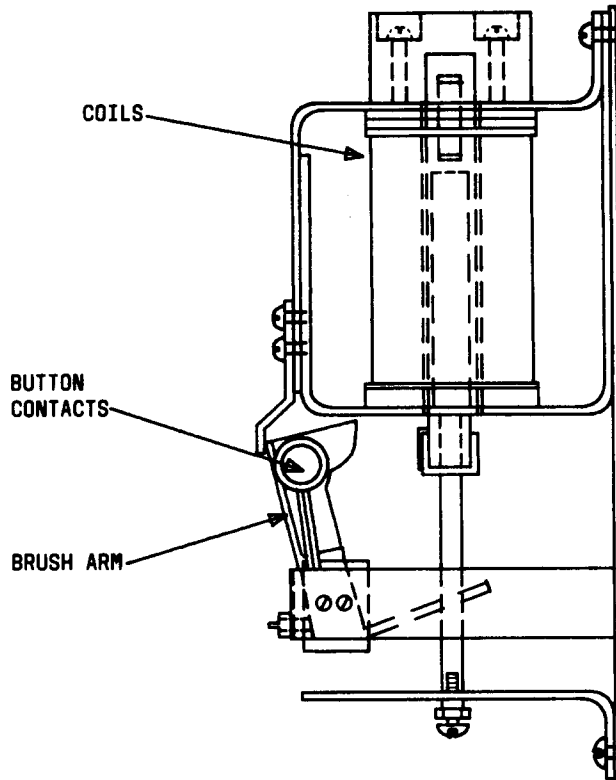

Fig. 3—Undervoltage Relay (Old Version)

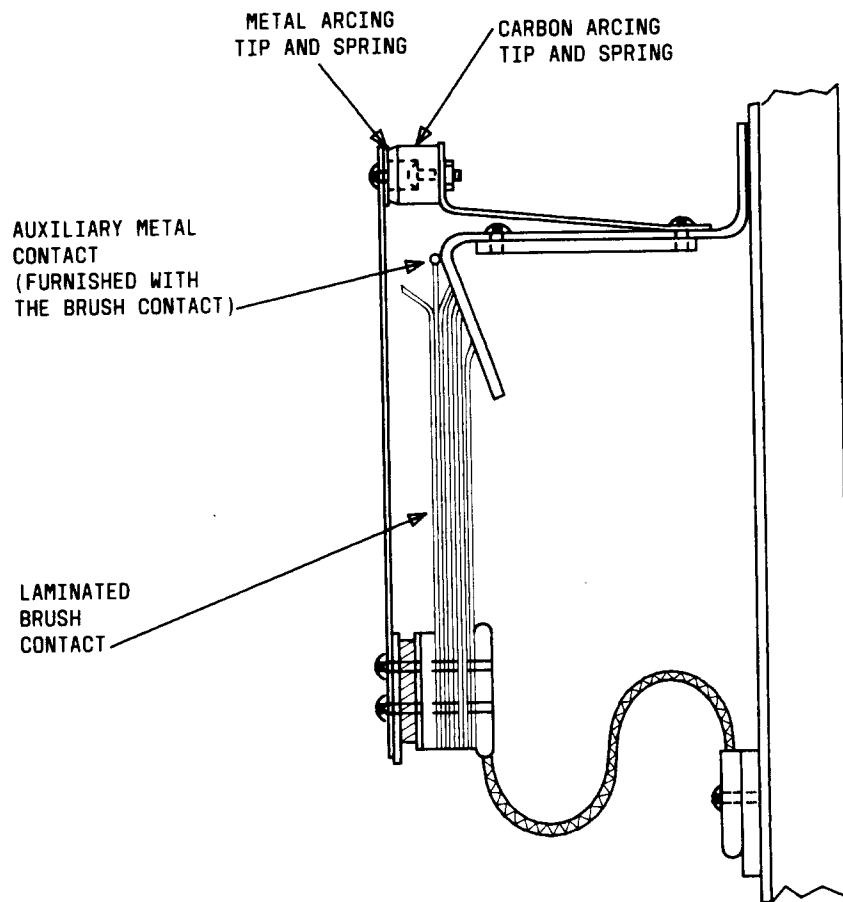

Fig. 4—Main Contacts (Old Version)

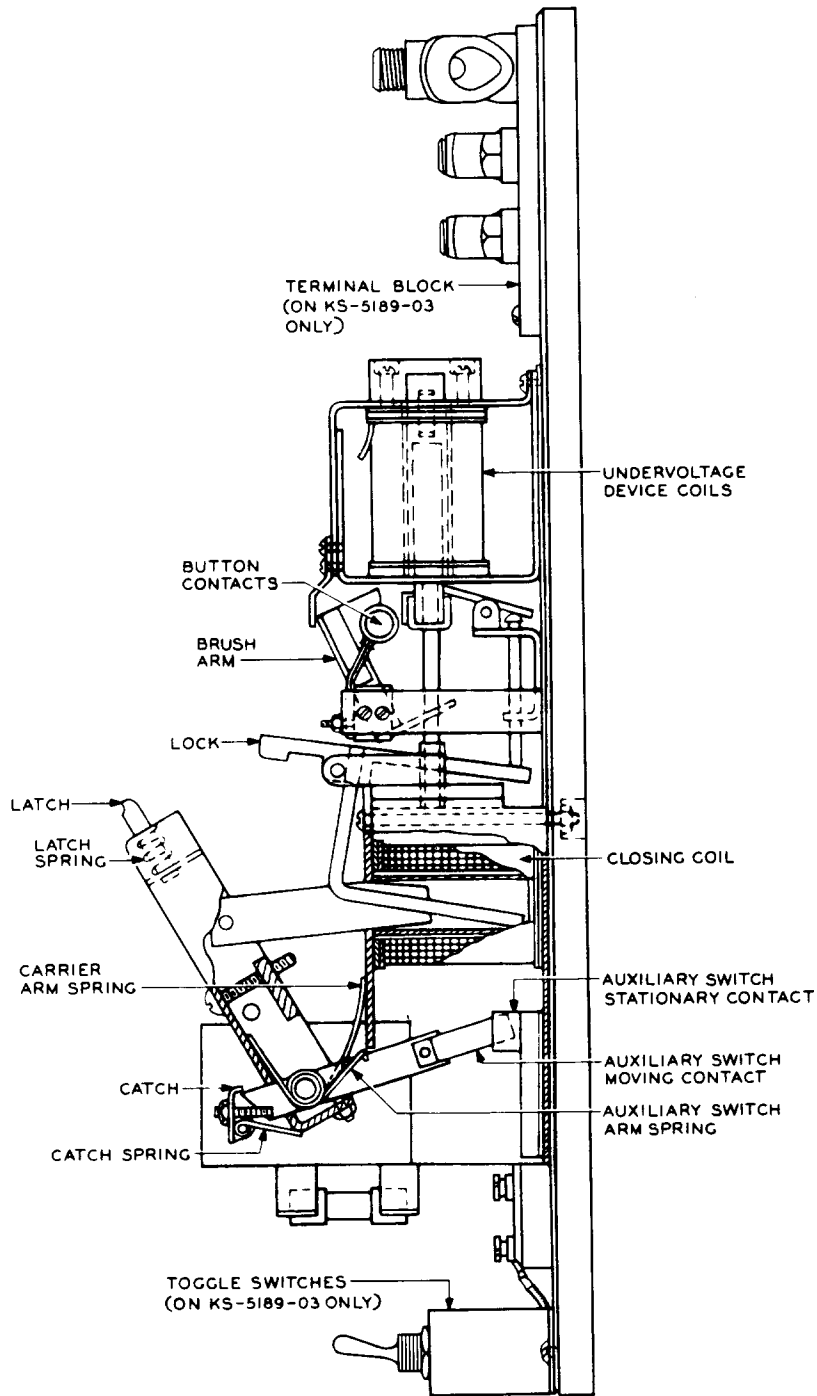

Fig. 5—Undervoltage Device and Contactor Mechanism (Main Contacts Open, Old Version)

3. REPLACEMENT PARTS

3.01 When ordering, give the name of the parts as shown in Fig. 1 through 8 of this section. The KS and list number should be included in the order, eg, undervoltage monitor, test switches, and contactors for emergency lighting relay switch KS-5189-03. Replacement parts are no longer made for the Palmer emergency lighting relay.

3.02 Miscellaneous parts such as screws, nuts, and washers, which are not named in the illustrations and which cannot be obtained locally should be ordered by describing the part and referring to the nameplate data, including the serial, KS and list numbers if known.

4. REPLACEMENT PROCEDURES

4.01 Provide emergency lighting service as required during the time that the switch is out of service. Take into consideration the local conditions such as the reliability of the regular lighting service, the length of time the switch will be out of service, and whether the work will be performed during daylight hours or at night. This may be accomplished by connecting the dc leads at the switch or leaving the switch so that it can be closed manually. The ac supply to the switch should, of course, be left disconnected and the fuse mounted on the switch should be removed for either of these conditions.

4.02 Before proceeding to make replacements, be sure that the switch is removed from service by opening the ac supply directly ahead of the switch and the dc supply at the fuse board. (The small fuse on the switch is in the circuit through the closing coil and its removal does not take the voltage from the main contacts.) After work is completed, energy for testing may be obtained by reconnecting the service.

4.03 Before making any replacements, be sure that all the replacement parts, tools, etc, are at hand, in order that the switch will be out of service a minimum of time. This applies particularly to operations such as replacement of the closing coil which requires a short fulcrum pin as covered below under "Auxiliary Switch Catch or Catch Spring", etc. After work is completed on a switch, check that the screws, nuts and bolts are tightened firmly, particularly those associated with current carrying parts.

4.04 No replacement procedures are given for screws or other small parts when the procedure consists of a simple operation.

4.05 Main Contacts:

(1) The movable and fixed contacts may be readily replaced after taking out the associated screws. In replacing, be certain to put back the four bushings and insulating shims on the crossbar.

(2) Line up the contacts by adjusting the movable contacts on the crossbar with the screws loose. Tighten the screws and close the contacts by hand. Note that the contacts close in the following sequence: (1) carbon contacts, (2) auxiliary metal contact, and (3) brush contact. They should open in the reverse order.

4.06 ♦The Undervoltage Monitor: The new emergency lighting relay switch KS-5189-03 has been designed with an undervoltage monitor. (See Fig. 6.) When replacing the voltage monitor, replace it with either Catalog 214A293 for 3-phase current or Catalog 214A304 for single-phase current, whichever matches the contactor on that unit. The undervoltage monitor should be replaced when there are problems.

4.07 Auxiliary Switch Catch or Catch Spring Auxiliary Switch Arm or Arm Spring Carrier Arm or Carrier Arm Spring, Carrier Arm Latch, or Spring:

(1) To replace the catch or spring, remove the cover over the catch by taking out the small screws on the sides. Pull out the catch fulcrum pin through the catch. The catch or spring shown in Fig. 8 may then be replaced.

(2) The auxiliary switch arm and spring, the carrier arm and spring and the two bushings are all held in place by the carrier arm fulcrum pin which must be removed to replace any of these parts. It is also recommended that this fulcrum pin be removed when replacing the carrier arm latch or spring. It is practically impossible to assemble these parts in place in the switch and then insert the fulcrum pin. However, this can be done readily with the parts removed from the switch assembly and with the aid of a pin 1/4 inch diameter and 1-5/16 inch to 1-7/16 inch long and slightly rounded on

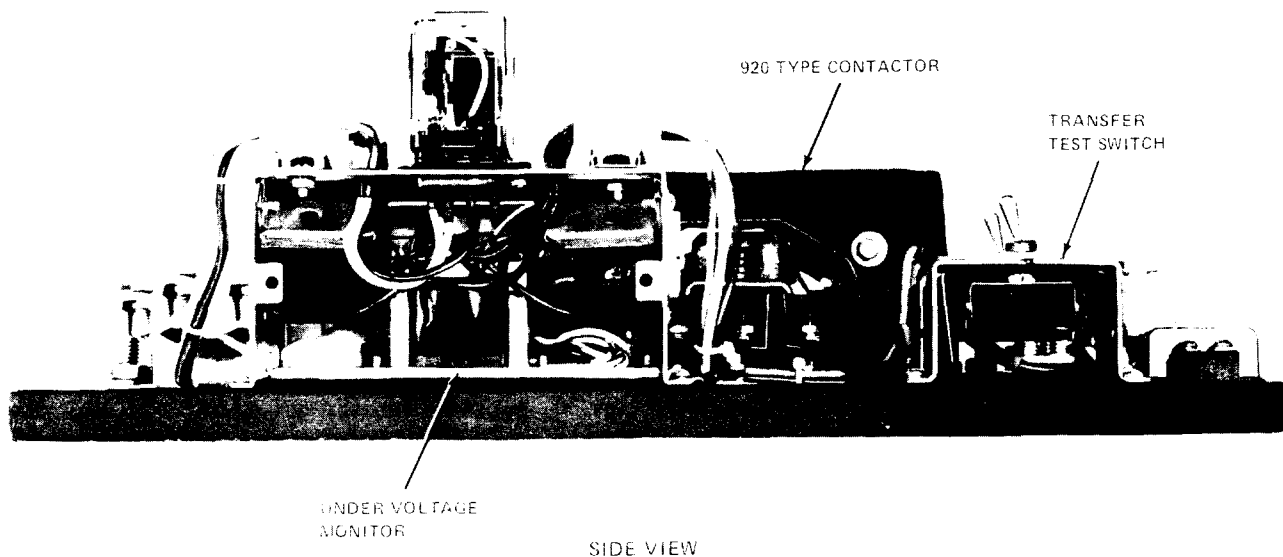

Fig. 6—Side View of the KS-5189-03 (New Version)

each end. This pin is shorter than the regular pin so that it will reach through the carrier arm only. Proceed to assemble by taking out the screw through the center of the carrier arm which holds the crossbar. Take out the catch and push the regular fulcrum pin out with the short pin and remove the carrier arm parts as a unit. In this way, the location of these parts can be seen.

(3) Replace the necessary parts and assemble the carrier arm parts on the short fulcrum pin. Check that the latch pin and spring are lubricated slightly with vaseline to insure smooth action. Put the mechanism in place in the switch and push the short pin out with the regular pin. Be careful that the carrier arm spring is against the coil cover as shown in Fig. 8. The washers on the fulcrum pin on each side of the carrier arm can best be put in place with a screwdriver after the long pin is inserted. Put in the catch and connect the crossbar switch to the carrier arm.

4.08 920 and 909-Type Contactors: The new emergency lighting relay switch KS-5189-03

has been designed for the 920-type contactor (See Fig. 7) or the 909-type contactor, depending on the current needs. These are modular units.♦

4.09 Closing Coil:

- (1) Although the coil can be replaced with the switch mechanism in the cabinet, it is easier to remove the contactor switch and undervoltage device to a bench. This may be dismantled by designating and disconnecting the wires to the securing screws shown in Fig. 8.
- (2) With the mechanism on the bench, take off the nameplate cover and the small base panel mounting the fuse. Remove the catch and push out the carrier arm fulcrum pin with the short pin (1/4 inch diameter and 1-5/16 inch to 1-7/16 inch long as referred to in the previous heading) and take out the carrier arm mechanism as a unit. Note the position of the washers on the armature lock and take off the cover. Unsolder the coil connections, replace the coil and solder the connections. Assemble the parts in the reverse order.

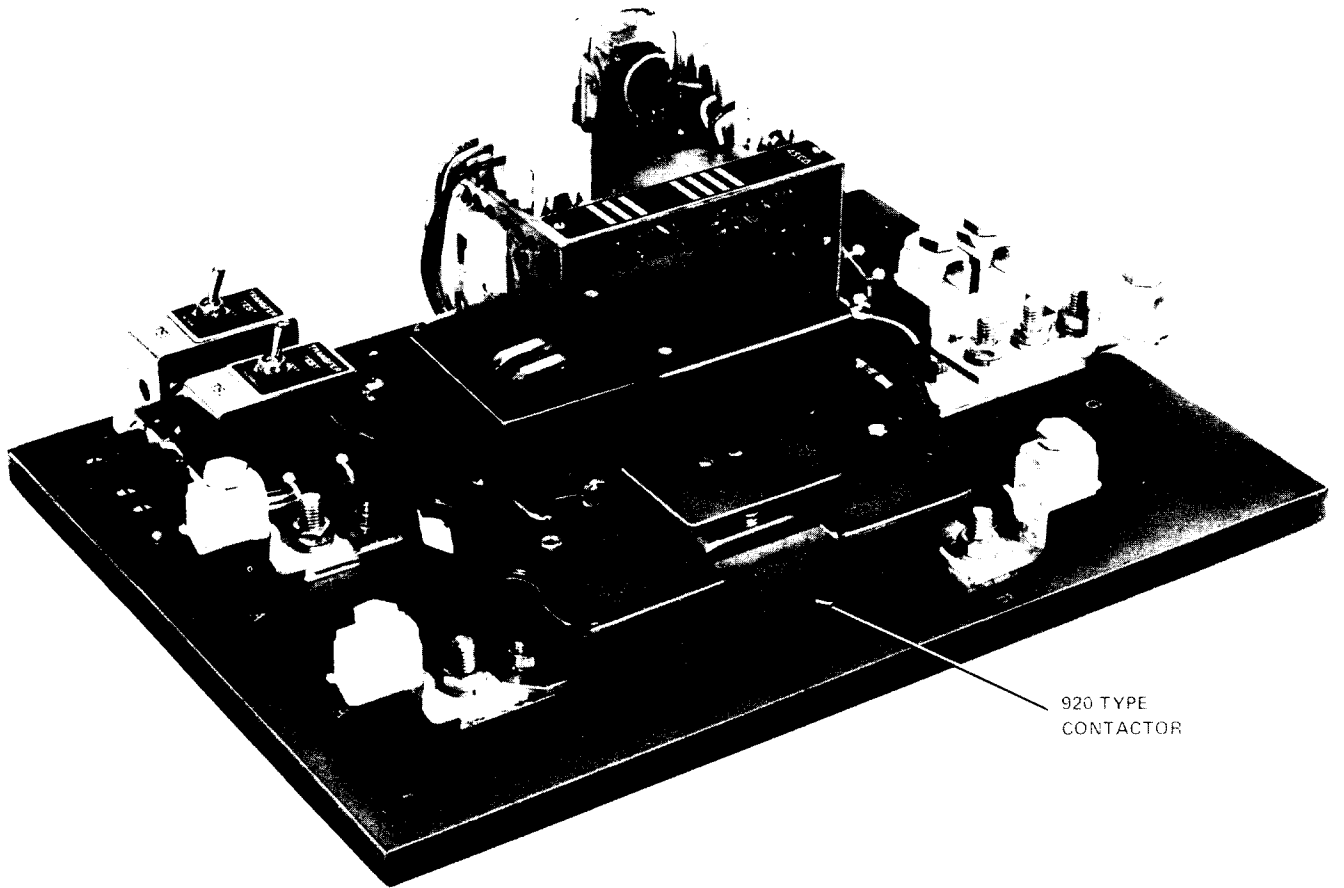

920 TYPE
CONTACTOR

Fig. 7—920 Type Contactor (New Version)

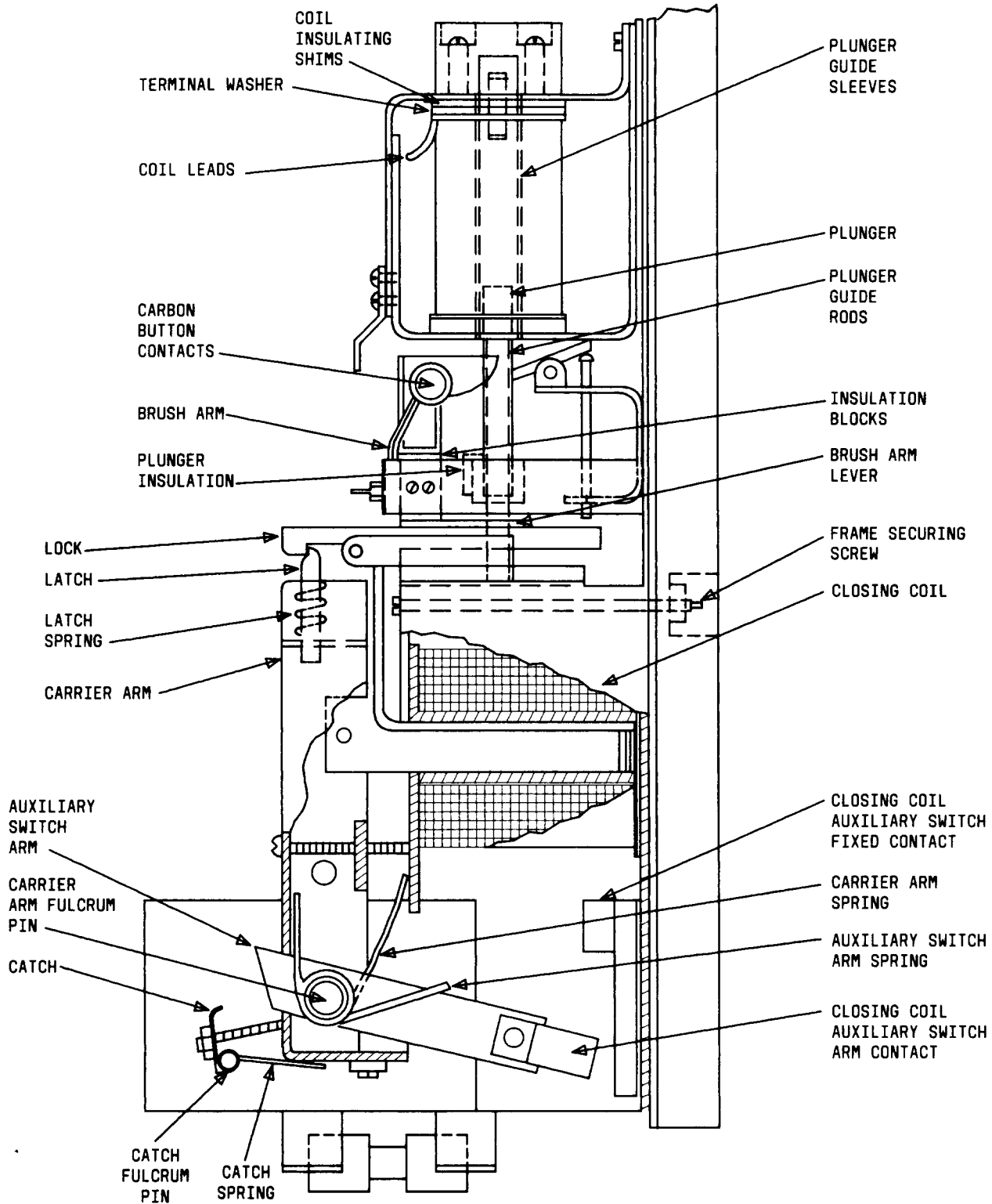

Fig. 8—Undervoltage Device and Contactor Mechanism (Main Contacts Closed, Old Version)

4.10 *Undervoltage Control Device Coils, Contact Buttons and Brush Arm:*

- (1) The contact buttons on the undervoltage device may be replaced readily after loosening the screws clamping them. Although the brush arm and insulating blocks on the undervoltage device are supported on a frame the same as on the undervoltage relay, it will be noted that the screws holding the blocks are inaccessible without removing the frame and unsoldering the leads. It is therefore easier to take the contactor mechanism out to a bench as covered under "Closing Coil."
- (2) With the mechanism on a bench, unsolder the leads to the contacts and remove the undervoltage device which gives access for removing the parts to be replaced. After replacement, assemble in the reverse order. Insert the plunger with the insulation side toward the brush arm and with the brush arm lever under the plunger, being careful that the guide rods fit into place. Adjust each carbon button for as tight a fit with the brush arm contact as possible and still allow the weight of the plunger to close the contacts.
- (3) Although the coils can be replaced with the contactor switch mechanism in the cabinet, it is recommended that the mechanism be taken out to a bench as covered above under "Closing Coil." The external coil leads are fastened internally in the coil and run through the switch mechanism at the base of the closing coil to the

two right-hand terminals. Since to disturb these leads might interfere with the operation of the switch, it is recommended that the leads be cut close to the coil after removing the screws holding the coil case to the base and taking the case apart.

- (4) The coils may be readily replaced. Carefully solder the cut leads to the respective leads on the replacing coil. Cover the soldered joint with friction tape. Note that the coil insulation is put back in place and that the ends of the plunger guide sleeves are fitted into the coil casing on both ends. The plunger should be inserted so that it will be above the brush arm lever, as shown in Fig. 8, and so that the insulation will be next to the brush arm. In mounting the case, be careful that the plunger guide rods fit into their holes without binding. Assemble the parts and be sure that the leads do not bind the switch.

4.11 *Undervoltage Relay Button Contacts, Brush Arm and Coils:*

The contact buttons and brush arm of the voltage relays, as shown in Fig. 1 and 2, may be replaced readily without taking off the relays. To replace the coils, note the wire connections to the relay and remove them. Remove the case ground connections and the relay which is held by the screws above the relay. The coils may then be readily replaced and the parts assembled. Replacement parts are no longer available for the old version.