

## AUTOMATIC ELECTRIC COMPANY 25-POINT ROTARY SWITCHES AND ASSOCIATED BANKS PIECE-PART DATA AND REPLACEMENT PROCEDURES

### 1. GENERAL

1.01 This section covers the information necessary for ordering parts to be used in the maintenance of D-87618, D-87625, D-87646A, D-87674A, D-87680A, D-87681A, D-87804A, D-87829A, and KS-1734 AECO 25-point rotary switches and associated banks. It also covers approved procedures for replacing these parts.

1.02 This section is reissued to revise piece-part information and replacement procedures. Detailed reasons for reissue will be found at the end of the section.

1.03 Part 2 of this section covers the piece-part numbers and the corresponding names of the parts which it is practicable to replace in the field in the maintenance of these switches and banks. No attempt should be made to replace parts not designated. Part 2 also contains explanatory figures showing the different parts. This information is called Piece-part Data.

1.04 Part 3 of this section covers the approved procedures for the replacement of piece parts listed in Part 2. This information is called Replacement Procedures.

### 2. PIECE-PART DATA

2.01 The figures included in this part show the various piece parts in their proper relation to other parts of the apparatus. The piece-part numbers of the various parts are given together with the names of the parts. When these names differ from those in general use in the field the latter names, in some cases, are shown in parentheses. Numbers prefixed by P are WECO piece-part numbers; all numbers prefixed by D in this section are AECO part numbers.

2.02 When ordering piece parts for replacement purposes, both the number and the name of the piece part should be given. If the part is an AECO part, the order should so state. For example, "AECO D-76252A Armature Adjusting Screw." Do not refer to the section number or any information shown in parentheses.

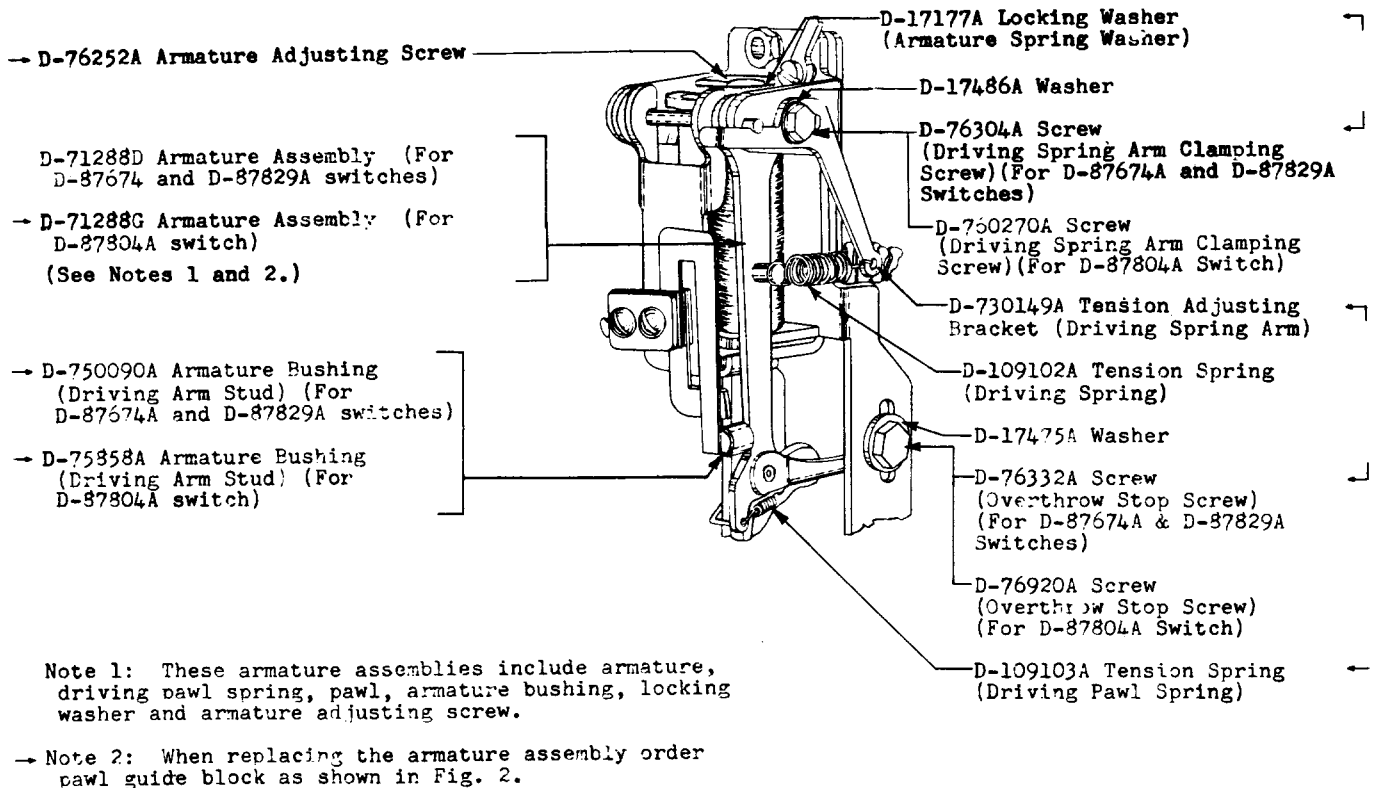

Fig. 1 - Armature and Pawl Assembly and Associated Parts - Heavy-duty-type Switches per D-87674A, D-87804A, and D-87829A

SECTION 030-766-801

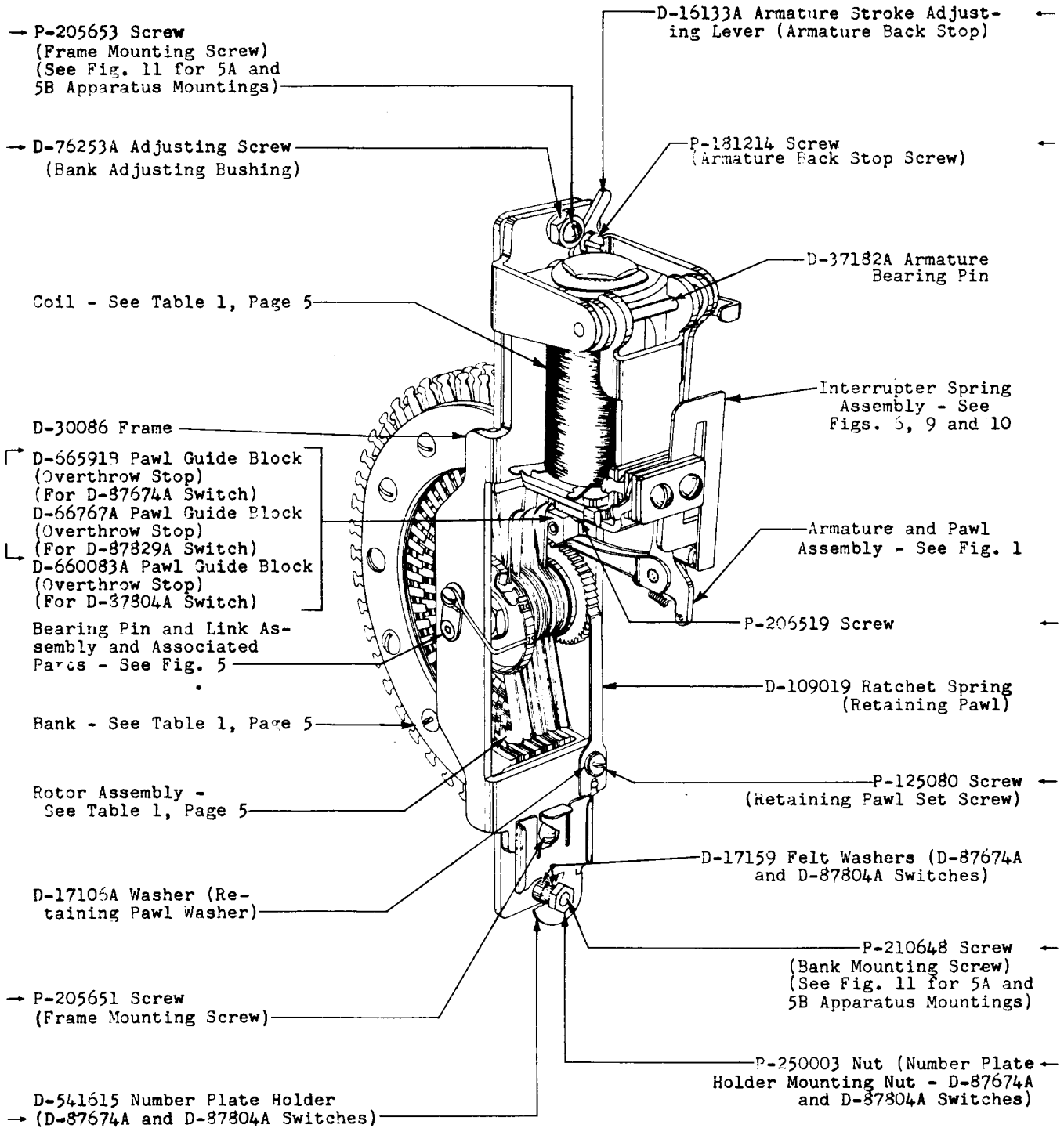

Fig. 2 - Heavy-duty-type Switches per D-87674A,  
D-87804A, and D-87829A

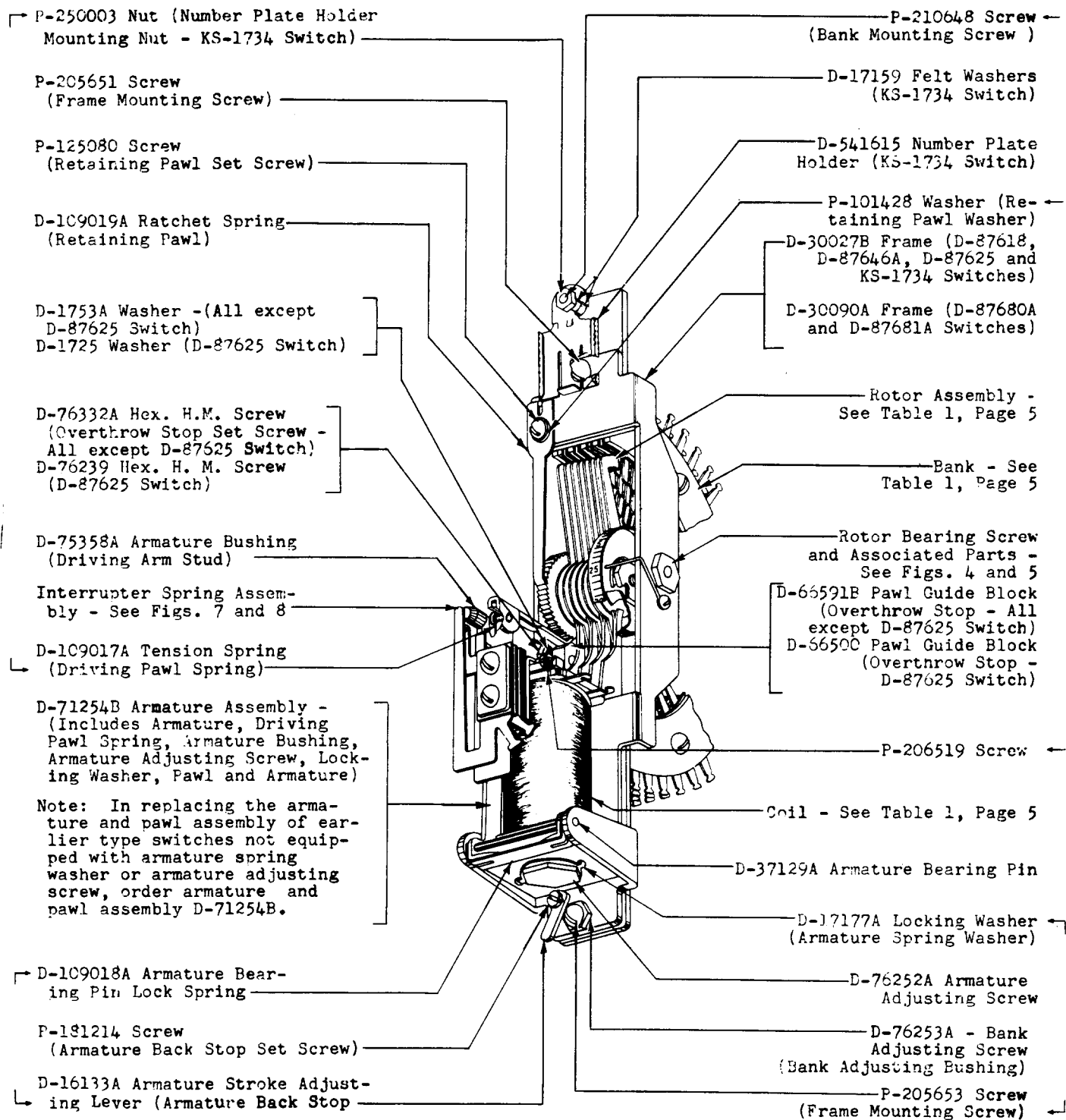

Fig. 3 - Light-duty-type Switches per D-87618, D-87625, D-87646A, D-87680A, D-87681A, and KS-1734

SECTION 030-766-801

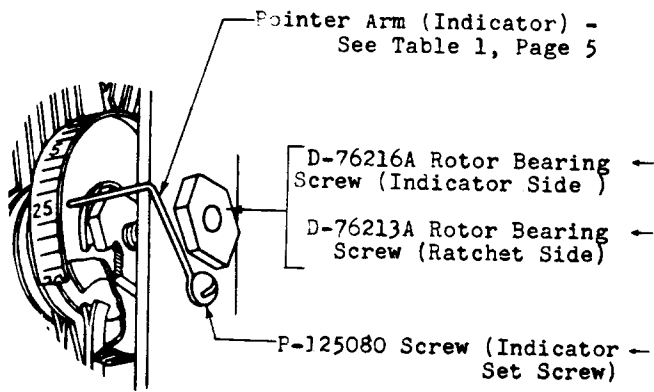

Fig. 4 - Rotor Shaft Bearing Screw and Associated Parts D-87618, D-87646A, D-87625, and KS-1734 Switches

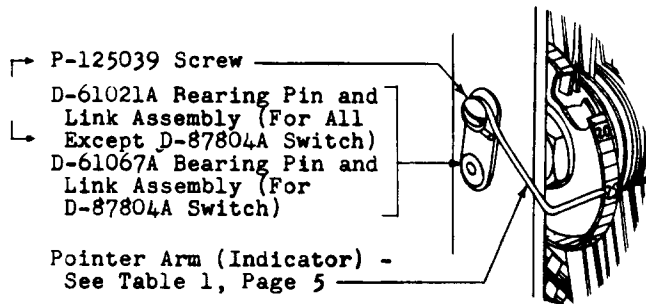

Fig. 5 - Bearing Pin and Link Assembly and Associated Parts D-87674A, D-87680A, D-87681A, D-87804A, and D-87829A Switches

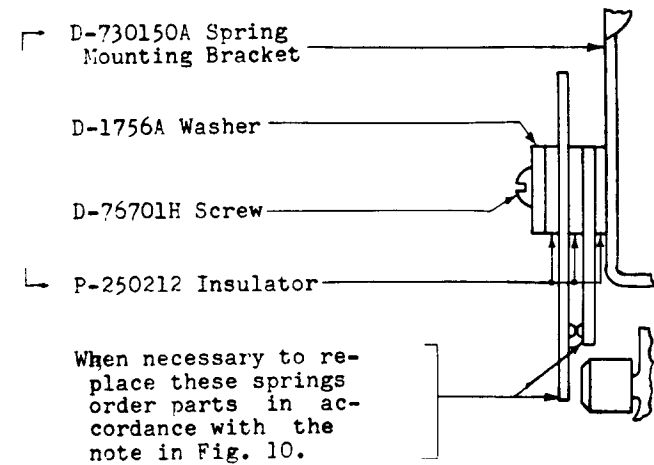

Fig. 6 - Interrupter Spring Assembly D-87674A Switch

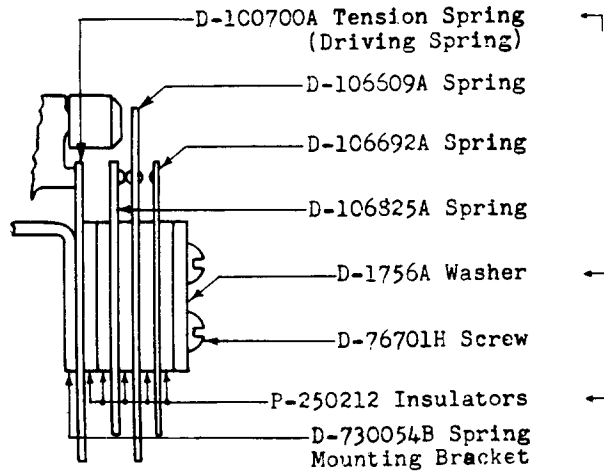

Fig. 7 - Interrupter Spring Assembly D-87618 and D-87680A Switches

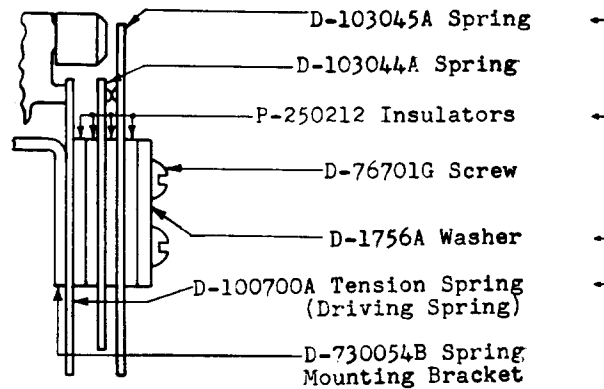

Fig. 8 - Interrupter Spring Assembly D-87625, D-87646A, D-87681A, and KS-1734 Switches

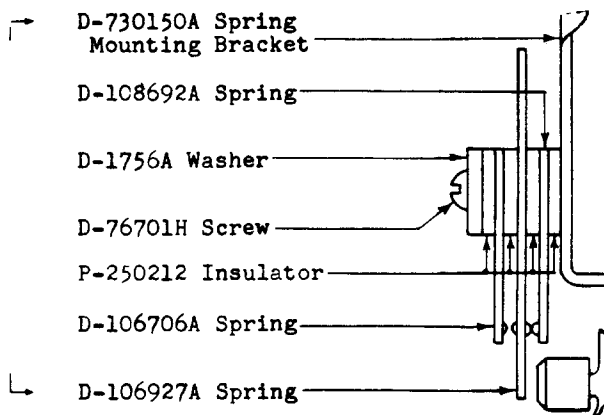

Fig. 9 - Interrupter Spring Assembly D-87829A Switch

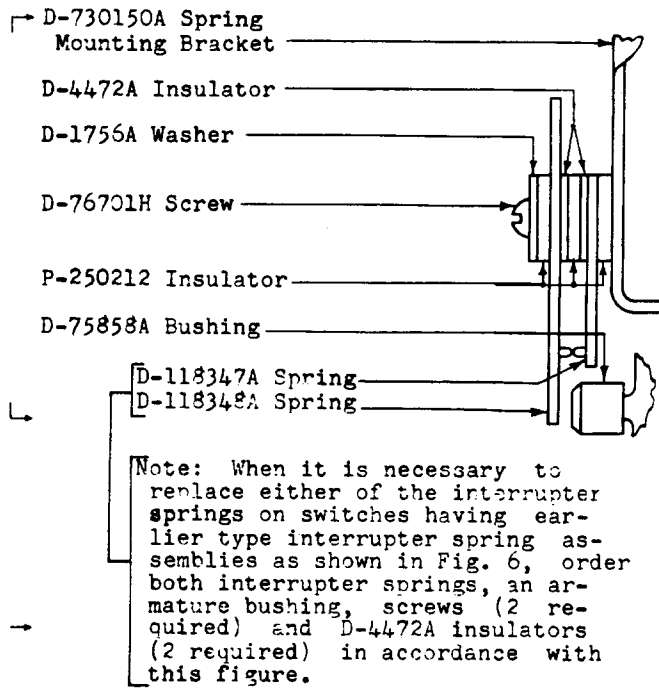

Fig. 10 - Interrupter Spring Assembly  
D-87804A Switch

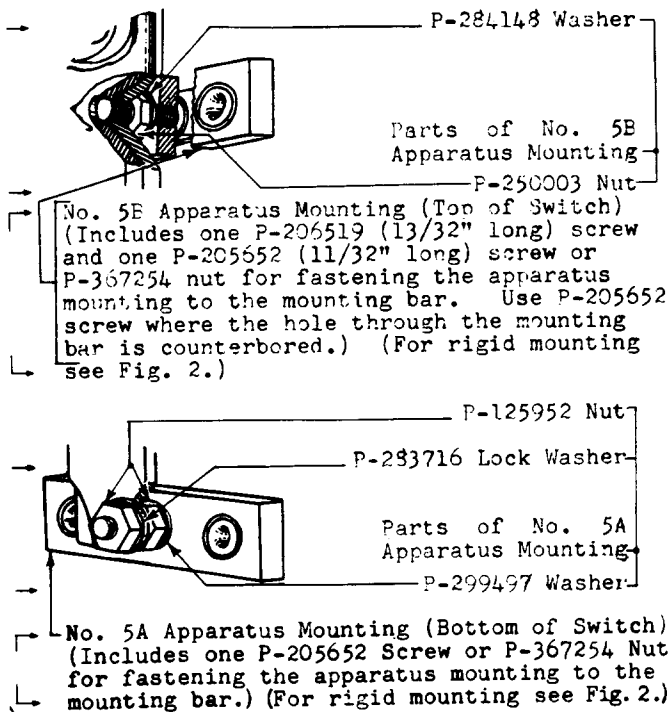

Fig. 11 - 5A and 5B Apparatus Mountings  
Used on D-87804A Switch Only

TABLE 1

Switch	Rotor Assembly	Bank	Coil	Pointer Arm.
D-87618	D-46124	D-41152C	D-280940	D-16167F
D-87625	D-46151	D-41164B	D-280940	D-16154B
D-87646A	D-46181A	D-41164B	D-280940	D-16167D
D-87674A	†D-46338A	D-41150C	D-281553	D-16167A
D-87680A	†D-46354A	D-41152C	D-280940	
D-87681A	†D-46375A	D-41164B	D-280940	D-16167D
D-87804A	†D-46338A	D-41150C	D-281553	D-16167A
D-87829A	†D-46354B	D-41152D	D-282101	
KS-1734	D-46179A	D-41150B	D-281101	D-16167A

† When replacing the rotor assembly on these switches order a bearing pin and link assembly per Fig. 5 and replace it at the same time.

3. REPLACEMENT PROCEDURES

3.001 List of Tools

Code or Spec No.	Description
<b>Tools</b>	
206	30-degree Offset Screwdriver
209	5/16-inch Hex. Open Single-end Offset Wrench
243	3/16- and 5/8-inch Hex. Closed Double-end Flat Wrench
344	Offset Screwdriver
417A	1/4- and 3/8-inch Hex. Open Double-end Flat Wrench
418A	5/16- and 7/32-inch Hex. Open Double-end Flat Wrench
676A	Feeder Brush Spacers (To Be Modified per 3.005) special
-	Hacksaw
-	4-ounce Riveting Hammer
-	1/16-inch Pin Punch
-	5-inch Diagonal Pliers
-	6-1/2-inch P-long-nose Pliers
-	3-inch Cabinet Screwdriver
-	4-inch Regular Screwdriver

3.002 Before making any replacement of the parts of a switch, make the associated circuit busy in the approved manner and block the necessary relays operated or nonoperated to isolate the switch circuit.

3.003 No replacement procedures are specified for screws or other parts where the procedure consists of a simple operation.

**SECTION 030-766-801**

3.004 After making any replacement of parts of a switch, the part or parts replaced shall meet the readjust requirements involved as specified in Section 030-766-702 for the light-duty switch and Section 030-766-701 for the heavy-duty switch. Other parts whose adjustments have been directly disturbed by the replacing operations shall be checked to the readjust requirements and an over-all operation check shall be made of the selector before restoring the circuit to service.

3.005 Modification of No. 676A Feeder Brush Spacers: Since the No. 676A feeder brush spacer cannot be used satisfactorily on switches associated with banks having 1, 2, or 4 feeder brushes, it will be necessary to modify one of these tools for use with each of these types of switches. Do this by sawing off the sides of the tools with a hacksaw as indicated in Fig. 12.

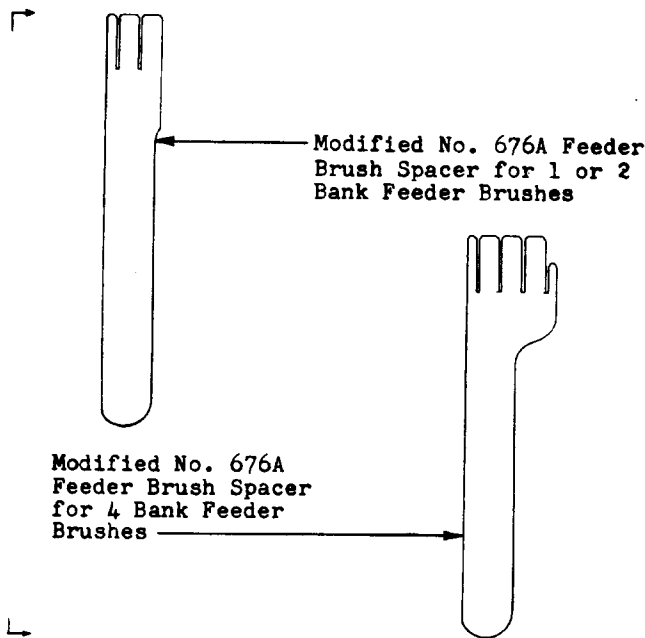

Fig. 12 - Illustrating Modified No. 676A Feeder Brush Spacers for Use With Selectors Equipped With 1-, 2-, and 4-bank Feeder Brushes

3.006 Removing Switch From Bank: In replacing some parts of the switch, it may be necessary to remove the switch from the bank in order to obtain access to the parts. To remove the switch from the bank, place a No. 676A feeder brush spacer over the feeder brushes in the position shown in Fig. 13. If the switch has 2- or 4-bank feeder brushes, use a feeder brush spacer which has been modified as outlined in 3.005. Remove the frame mounting screws with the 4-inch regular screwdriver. Pull the switch frame forward (away from the bank) until the rotor brush assembly is clear of the feeder brushes. Where there

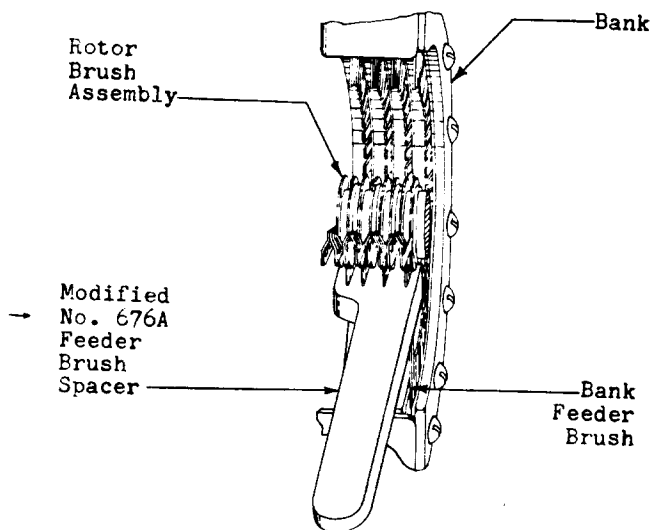

Fig. 13 - Method of Using Modified No. 676A Feeder Brush Spacer

appears to be any danger of the interrupter spring or coil wires breaking when this operation is performed, tag and unsolder the wires before removing the switch from the bank. To reassemble the switch and bank, lower the switch into place, taking care that the rotor brushes engage the bank terminals properly and that the feeder brushes engage the proper rotor brush hubs. Then remount and tighten the frame mounting screws and remove the feeder brush spacer. Resolder any wires which were removed.

3.01 Interrupter Spring Assembly: To replace a part in the interrupter spring assembly, unsolder the wires which are connected to its terminal lugs. Then remove the screw which mounts the spring mounting bracket with the No. 344 offset screwdriver and remove the bracket and spring assembly. Loosen the spring assembly clamping screws with the 4-inch regular screwdriver. Remove the part which is to be replaced and place the new one in position holding the assembly so that the springs are in line with each other. Reassemble and tighten the interrupter spring assembly clamping screws. Mount the spring mounting bracket in position and tighten the mounting screw. Resolder the wires. When mounted, the interrupter spring should line up centrally with the driving arm stud.

3.02 Overthrow Stop: Remove the overthrow stop setscrew with the No. 418A wrench. Replace the stop and securely tighten the setscrew. If there is not sufficient space to remove the overthrow stop, remove the switch from its bank as covered in 3.006 and then replace the overthrow stop. Remount the switch as outlined in 3.006.

3.03 Driving Pawl Spring (Heavy-duty-type Switch): Disengage the spring from the armature with the long-nose pliers and disengage the other end of the spring from the pawl. Engage one end of the new spring in the eye of the pawl and attach the other end of the spring to the armature.

3.04 Driving Pawl Spring (Light-duty-type Switch): Disengage the lower end of the spring from the driving arm with the long-nose pliers and remove the spring from the driving pawl lug. Place the new spring over the pawl lug. Hitch the short end behind the pawl and hitch the lower end behind the driving arm.

3.05 Driving Spring (Heavy-duty-type Switch): Loosen the driving spring arm clamping screw. Remove the driving spring from the lug on the driving arm with the long-nose pliers and disengage the other end of the spring from the driving spring arm. Engage one end of the new driving spring in the eye of the driving spring arm and attach the other end of the spring to the driving arm.

3.06 Driving Spring Arm (Heavy-duty-type Switch): Remove the driving spring as covered in 3.05. Remove the driving spring arm clamping screw with the No. 417A wrench and remove the driving spring arm. Mount the new driving spring arm, rotate the arm into the slot in the armature bearing pin, and securely tighten the clamping screw.

3.07 Armature Adjusting Screw and Armature Spring Washer: Remove the bank adjusting screw and the frame mounting screw with the No. 418A wrench and the 3-inch cabinet screwdriver. Remove the armature adjusting screw with the No. 243 wrench and remove the armature spring washer. In replacing the parts, hold the washer and screw in position by hand while turning the armature adjusting screw with the wrench.

Armature Bearing Pin Locking Spring (Light-duty Switch Only) and Armature Bearing Pin

3.08 Light-duty-type Switch: Insert the 3-inch cabinet screwdriver between the pin locking spring and the armature and turn the

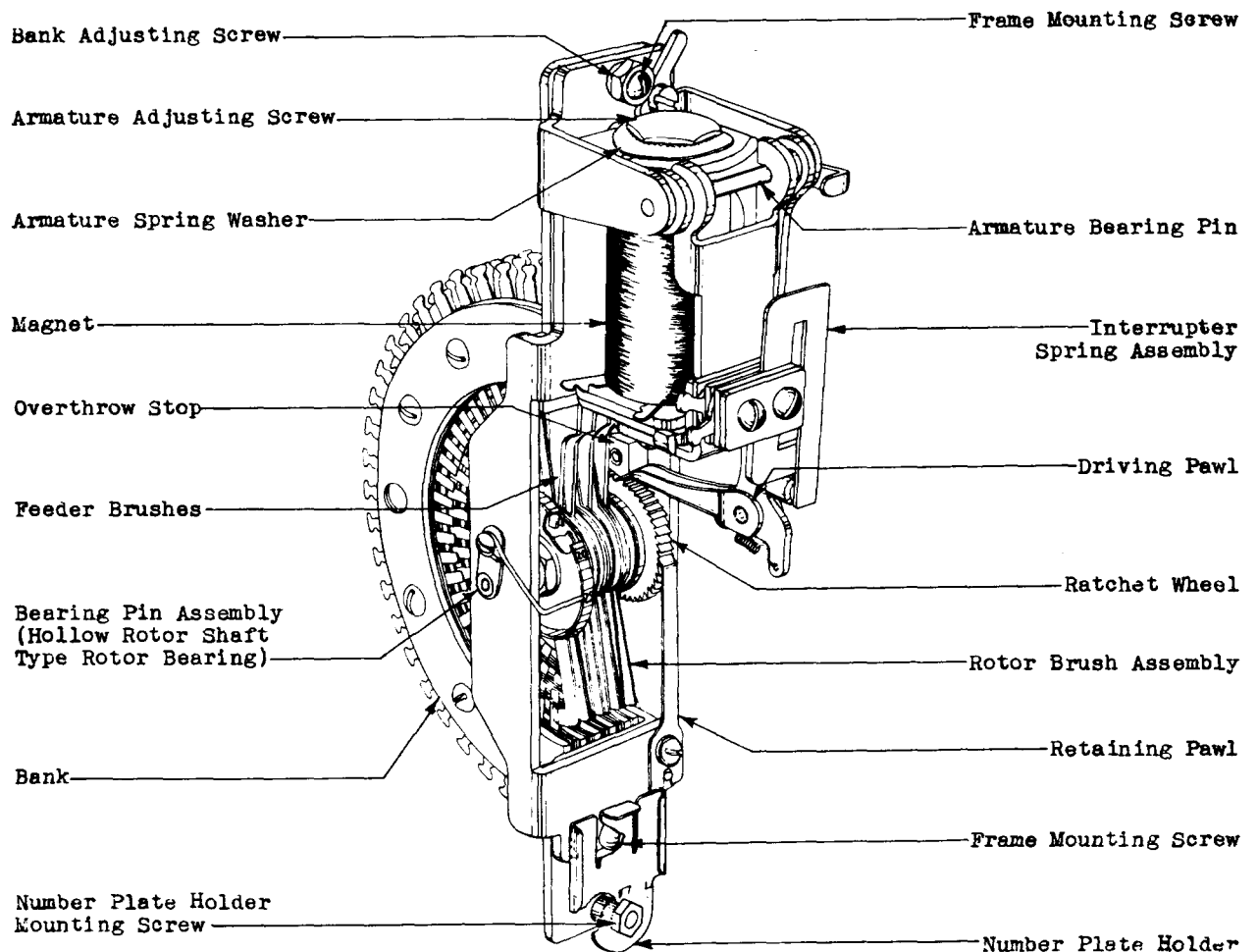

Fig. 14 - Designation of Parts Heavy-duty-type Switch

screwdriver so that the spring is forced away from the armature. If the space does not permit the removal of the armature bearing pin without removing the switch from the bank, remove the switch from the bank as covered in 3.006. Remove the armature bearing pin by driving it out with the 4-ounce riveting hammer and 1/16-inch pin punch. Substitute new parts as required and position the armature bearing pin locking spring by forcing it into position by hand.

3.09 Heavy-duty-type Switch: Remove the driving spring from the armature as covered in 3.05. Loosen the driving spring arm clamping screw with the No. 417A wrench and raise the arm so that it is free of the armature bearing pin. Loosen the screw that mounts the spring assembly mounting bracket with the No. 344 offset screwdriver. If space does not permit removal of the armature bearing pin without removing the switch from the bank, remove the switch from the bank as covered in 3.006. Remove the armature bearing pin with the 1/16-inch pin punch and 4-ounce riveting hammer. Mount the new pin and reposition the parts, making sure that the driving spring arm is in the bearing pin slot. Tighten all screws securely. Remount the driving spring.

#### Armature and Pawl

3.10 Heavy-duty-type Switch: Remove the armature bearing pin as covered in 3.09 and remove the armature and pawl. Position the new armature and pawl and remount the bearing pin. Reposition the parts making sure that the driving spring arm is in the bearing pin slot. Tighten all screws securely. Remount the driving spring.

3.11 Light-duty-type Switch: Lower the overthrow stop by loosening the overthrow stop screw with the No. 418A wrench. Remove the armature bearing pin locking spring and armature bearing pin as covered in 3.08. Remove the armature and pawl assembly and substitute a new armature and pawl. Hold the armature so that it is just to the left of the spring assembly and the armature adjusting screw is almost parallel with the spring assembly. Slip the pawl between the ratchet wheel and the overthrow stop. While keeping the pawl in this position, rotate the armature to a position below the magnet. Then carefully move the armature forward until the driving arm is beyond the driving spring. Position the armature below the magnet. Take care not to damage the armature. Remount the armature bearing pin and the armature bearing pin locking spring.

#### Rotor Assembly, Rotor Bearing Pin and Link Assembly, Rotor Bearing Screws, and Indicator

3.12 In replacing the rotor assembly first rotate it until the brushes are in the horizontal position. Put the proper No. 676A feeder brush spacer, modified as covered in 3.005, in the position shown in Fig. 13.

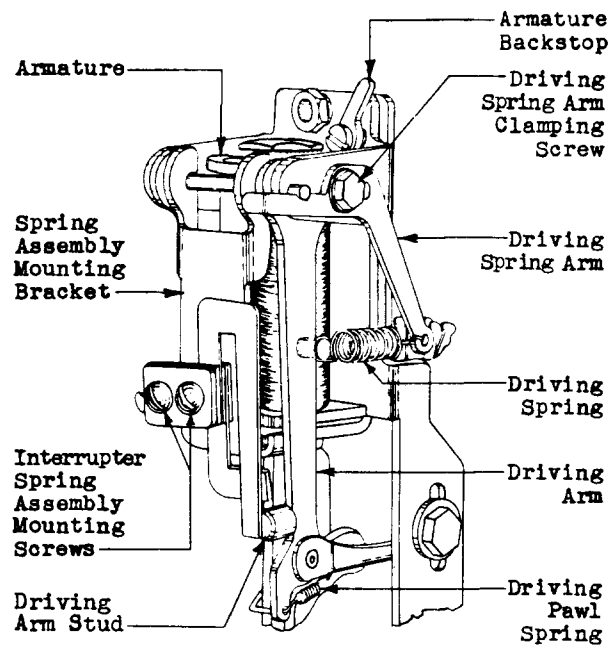

Fig. 15 - Designation of Parts  
Heavy-duty-type Switch

3.13 Switches Equipped With Hollow Type of Rotor Bearing Shaft: If space permits the removal of the indicator and shaft without removing the selector from its bank, first remove the retaining pawl mounting screw with the 3-inch cabinet screwdriver and remove the retaining pawl. Then remove the indicator clamping screw with the 3-inch cabinet screwdriver. Remove the indicator, the bearing pin and link assembly, and the rotor brush assembly.

3.14 If there is not sufficient space to remove the indicator, and bearing pin and link assembly, remove the switch from its bank as covered in 3.006, remove the indicator clamping screw, and turn the switch to the right or left as required sufficiently to permit the removal of the parts. Grasp the rear ends of the rotor brushes close to the rotor brush hubs and remove the rotor brush assembly from the rear of the switch frame. This will not necessitate removing the retaining pawl. Reassemble the parts as outlined in 3.16.

3.15 Switches Equipped With the Bearing Screw Type of Rotor Bearing Shaft: To replace a rotor assembly on a switch equipped with the bearing screw type of rotor bearing shaft shown in Fig. 16, remove the retaining pawl mounting screw with the 3-inch cabinet screwdriver and remove the retaining pawl. Remove the rotor bearing screws on both sides of the switch frame with the No. 417A wrench. The screw on the side of the switch nearer the ratchet wheel has a right-hand thread and is loosened by turning in a counterclockwise direction. The screw on the side of the switch further from the



ratchet wheel has a left-hand thread and is loosened by turning in a clockwise direction. Remove the indicator setscrew with the No. 206 offset screwdriver. Remove the rotor assembly.

3.16 Reassemble the switch, substituting new parts as necessary, and securely re-tighten all screws. Make sure that the rotor brush assembly is approximately centered in the switch frame and that there is a slight amount of sideplay in the bearings.

3.17 Coil: Unsolder the wires from the coil terminals and remove the coil mounting screw with the No. 344 offset screwdriver. Remove the interrupter spring assembly mounting bracket and allow the assembly to hang by its wires, exercising care not to damage the wiring. Remove the armature bearing pin as covered in 3.08 or 3.09. Remove the coil. Substitute the new coil and reassemble the parts in the reverse order of removal.

#### Driving Arm Stud

3.18 Remove the coil mounting screw with the No. 344 offset screwdriver. Remove the interrupter spring assembly mounting bracket and allow the assembly to hang by its wiring, taking care not to damage the wiring.

3.19 Cut the old stud loose from the driving arm lug with the 5-inch diagonal pliers.

3.20 Before placing a new stud on the lug, heat the stud until it becomes pliant by placing it near a hot soldering copper. Then place it on the lug of the driving arm and press against it with the long-nose pliers until it assumes its correct position against the shoulder on the interrupter driving arm.

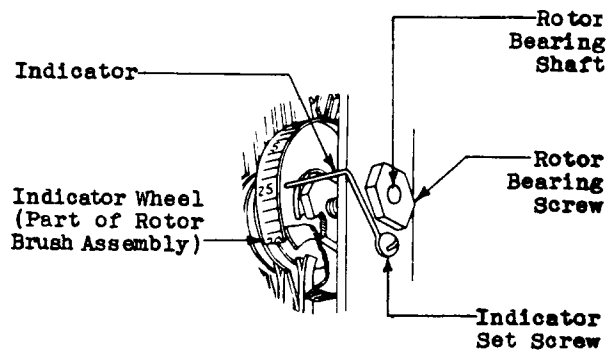

Fig. 16 - Indicator and Rotor Bearing Screws of Switches Equipped With Bearing Screw Type of Rotor Bearing Shaft

3.21 Remount the interrupter spring mounting bracket and securely tighten the coil mounting screw.

#### Banks

3.22 To replace a bank, remove the switch from the bank as covered in 3.006. Tag and unsolder the wires to the bank terminals, remove the frame mounting screws with the 4-inch regular screwdriver and remove the bank. Mount the new bank and resolder the bank wiring. Remount the switch as covered in 3.006.

#### Nonrigid Mounting

3.23 To replace the nonrigid mounting remove the mounting screws or mounting nuts with the 3-inch cabinet screwdriver or No. 209 wrench and pull the switch and associated bank forward away from the frame sufficiently to remove the mountings from the bank. Take care not to damage the wiring and soldered connections. Then remove the upper or lower non-rigid mounting from the bank as required using the No. 209 wrench to loosen the nut on the No. 5A apparatus mounting or by turning the No. 5B apparatus mounting.

3.24 Mount the No. 5A apparatus mounting by inserting the screw on the mounting through the hole in the bank frame and securing it with the nut and washer. Mount the No. 5B apparatus mounting by inserting the screw on the mounting into the tapped hole in the bank frame and turning the mounting until the screw is tight and then continue turning until the mounting is horizontal. Mount the bank and associated apparatus mountings on the frame. Where the apparatus mounting is secured to the frame by a screw, insert the screw through the mounting bar and into the apparatus mounting from the rear. Where the apparatus mounting is provided with a stud, insert the stud through the mounting bar from the front, and secure it with the nut.

#### REASONS FOR REISSUE

1. To revise the piece-part information.
2. To revise the list of tools (3.001).
3. To revise the replacement procedures for armature bearing pin (3.09).
4. To revise the replacement procedures for the armature and pawl (3.10).
5. To revise the replacement procedures for the coil (3.17).
6. To revise the replacement procedures for nonrigid mounting (3.23 and 3.24).