

Dsm #820 B

SWITCH PER D-159393 AND ASSOCIATED MOTOR GENERATOR FOR A3 AND A5 PRIVACY SYSTEMS REQUIREMENTS AND ADJUSTING PROCEDURES

1. GENERAL

1.01 This section covers the D-159393 cam switching unit, Fig. 1, and associated motor generator, Fig. 2, used in the A3 and A5 privacy systems.

1.02 This section is reissued to change the type of lubricant, to revise the procedure for lubricating the upper and lower gear boxes, and to revise the procedure for assembling the motor generator bearings.

1.03 Reference shall be made to Section 020-010-711 covering General Requirements and Definitions for additional information necessary for the proper application of the requirements listed herein.

1.04 *Checking and Readjusting for Requirements:* Unless otherwise specified, all requirements shall be checked and readjustments made with the motor generator stopped.

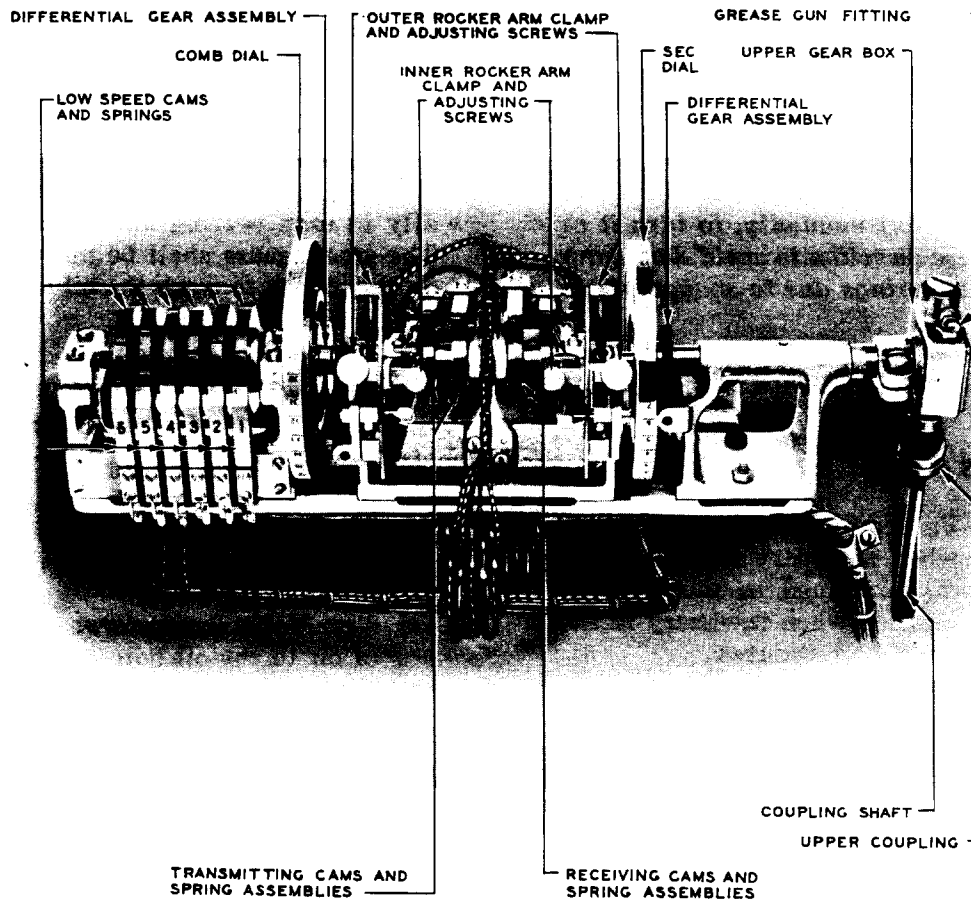

Fig. 1 - D-159393 Cam Switching Unit

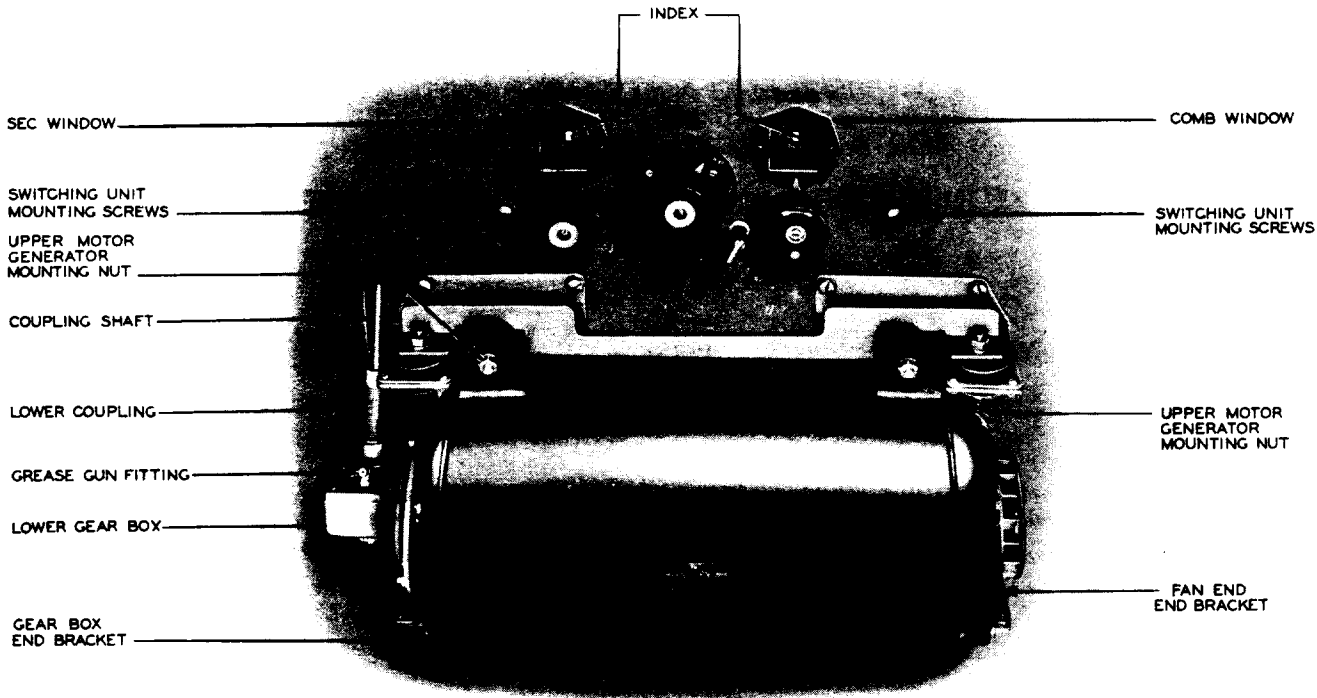

Fig. 2 - Motor Generator

1.05 **Caution:** Care shall be exercised when turning the coupling shaft (or the shaft stub in upper gear box) manually, to turn it in the proper clockwise direction to avoid damaging the high-speed cam springs due to snagging.

1.06 **Caution:** The two differential gear assemblies shall not be unmeshed in the field.

2. REQUIREMENTS

2.01 **Cleaning:** The cam switching unit shall be cleaned when necessary in accordance with the procedures contained in this section. Contacts shall be cleaned when necessary in accordance with approved procedures.

2.02 Lubrication

(a) **KS-7470 Oil:** The following parts shall be lubricated with KS-7470 oil:

(1) **Cam Shaft Bearings:** Apply 2 drops of oil in each of the five cam shaft bearing oil holes.

Use the 486A tool (oil can).

(2) **Differential Gear Assemblies — Bearings and Gear Teeth:** Apply oil liberally to each bearing and to the gear teeth. The small gears shall be moved to and fro on the shafts to work the oil in.

Use the 486A tool (oil can).

(3) **Upper Gear Box Thrust Bracket:** Apply 2 drops of oil to the rubbing parts of the bracket.

Use the 486A tool (oil can).

Motor Generator Ball Bearings

(4) **New Motor Generators:** Apply 20 drops of oil to the oil hole at the top of each bearing.

Remove the nozzle from the 486A tool (oil can) and use the oil can without the nozzle.

(5) **Old Motor Generators:** To reduce maintenance time and effort and to improve bearing lubrication, it is recommended that the bearings be modified as described in 3.02(7) to (16). After modification, rou-

tine lubrication shall be with 20 drops of oil applied to the oil hole at top of each bearing.

Remove the nozzle from the 486A tool (oil can) and use the oil can without the nozzle.

(b) **MIL-G-3278A Grease:** The following parts shall be lubricated with MIL-G-3278A grease.

(1) **Cams:** Apply a thin film of grease on the cam shoe contacting surfaces of the six low-speed and four high-speed cams.

Upper and Lower Gear Boxes

New and Modified Gear Boxes

(2) **Initial Lubrication:** At time of installation of new gear boxes (which are shipped from factory without any lubricant in them), and at time of changeover to improved lubricant for old gear boxes that have been modified, the initial lubrication shall be as follows: Remove gear box cover and fill gear box 2/3 full with grease. Replace cover and before motor is run remove grease exit hole screw and apply grease through grease fitting with the 5958 Lincoln grease gun until a reasonable amount of new grease has extruded through the grease exit hole. Run motor for 1 hour to allow for grease expansion before grease exit hole screw is replaced.

(3) **Routine Lubrication:** Remove grease exit hole screw and apply grease through grease fitting with the 5958 Lincoln grease gun until the old grease has been removed and a reasonable amount of new grease has extruded through the grease exit hole. Run motor for 1 hour to allow for grease expansion before grease exit hole screw is replaced.

Old Gear Boxes Not Modified

(4) **Initial Lubrication:** The initial lubrication with improved lubricant for old gear boxes that have not been modified shall be as follows: Remove gear box cover, clean out old oil and fill gear box 2/3 full with grease.

(5) **Routine Lubrication:** Remove gear box cover, clean out old grease, and fill gear box 2/3 full with new grease.

(c) **Recommended Lubrication Interval:** After turnover, it is recommended that the parts be lubricated at the interval given below.

PART	INTERVAL
Cam Shaft Bearings	3 months*
Cams	6 months
Upper and Lower Gear Boxes	6 months
Upper Gear Box Thrust Bracket	6 months
Differential Gear Assemblies — Bearings and Gear Teeth	3 months*
Motor Generator Ball Bearings	6 months

* The 3-month intervals specified above may be extended to 6 months if periodic inspections have indicated that local conditions are such as to ensure that the requirements will be met during the extended intervals.

2.03 Record of Lubrication: During the period of installation a record shall be kept, by date, of the lubrication of the unit, and this record shall be turned over to the telephone company with the equipment. If no lubricating has been done, it shall be so stated.

2.04 Alignment of Coupling Shaft with Gear Box Shafts: The coupling shaft shall be approximately in line with the stub shafts of the upper and lower gear boxes.

Gauge by eye as the motor generator is running and note that there is no excessive wobble of the shaft.

Low-speed Cam Spring Assemblies (2.05 through 2.10)

2.05 Relation Between Cam and Cam Shoe: The cam shoe on the inner contact spring shall not overlap the width of the cam more than 1/64 inch.

Gauge by eye.

2.06 Contact Alignment: Contacts shall line up so that the one having the smaller diameter falls entirely within the circumference of the larger.

Gauge by eye.

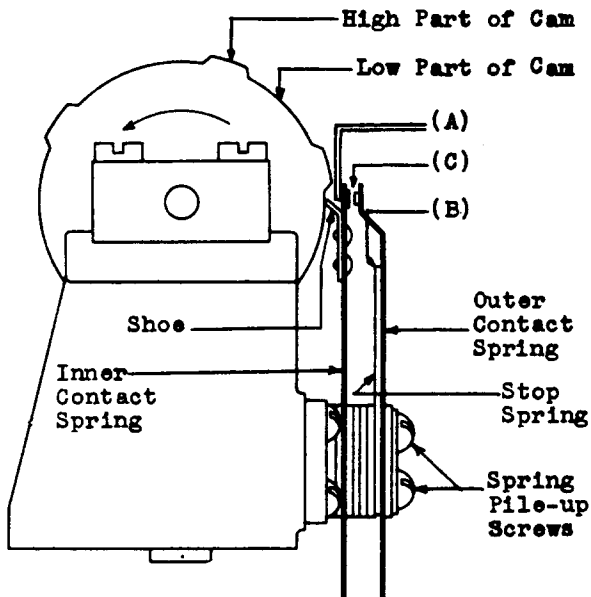

Fig. 3 - Low-speed Cam Assembly

2.07 Pressure of Cam Shoe on Cam: Fig. 3(A)—The pressure of the shoe of the inner contact spring against the *low* part of the cam, measured at the top of the inner contact spring, shall not exceed 25 grams.

Use the 79C gauge.

2.08 Position of Outer Contact Spring: Fig. 3(B) — With the shoe of the inner contact spring on the *low* part of the cam, the outer contact spring shall rest on the stop spring, at least at the free end of the stop spring.

Gauge by eye.

2.09 Contact Separation: Fig. 3(C) — With the shoe of the inner contact spring on the *low* part of the cam, the separation between the contacts of the inner and outer springs shall be

Test Min 0.008 inch Max 0.027 inch
Readjust Min 0.010 inch Max 0.025 inch

Use the 66D gauge.

2.10 Contact Pressure: Fig. 4(A) — With the shoe of the inner contact spring on the *high* part of the cam, the contact pressure be-

tween the inner and outer springs, measured at the top of the outer spring, shall be

Test Min 15 grams Max 110 grams
Readjust Min 20 grams Max 100 grams

Use the 79C gauge.

High-speed Cam Spring Assemblies (2.11 through 2.16)

2.11 Relation Between Cam and Cam Shoe:

The cam shoe on the lower contact spring shall not overlap the width of the cam more than 1/64 inch.

Gauge by eye.

2.12 Contact Alignment: Contacts shall line up so that the one having the smaller diameter falls entirely within the circumference of the larger.

Gauge by eye.

2.13 Pressure of Cam Shoe on Cam: Fig. 5(A)—

The pressure of the shoe of the lower contact spring against the *low* part of the cam, measured at the end of the lower contact spring, shall be

Test Min 5 grams Max 25 grams
Readjust Min 10 grams Max 20 grams

Use the 70D gauge.

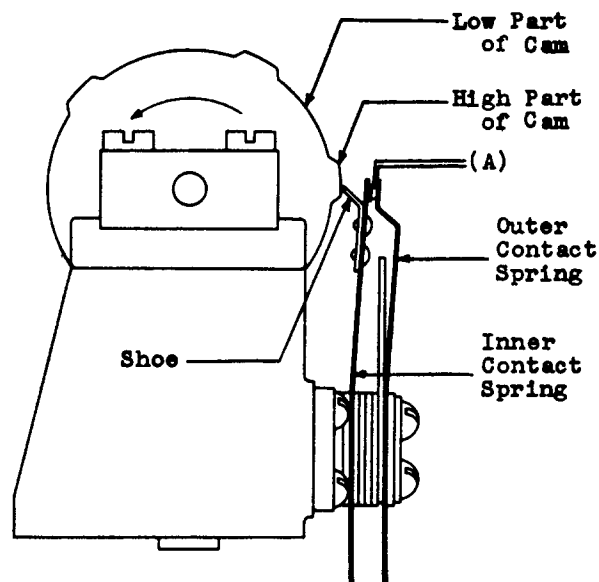

Fig. 4 - High-speed Cam Assembly

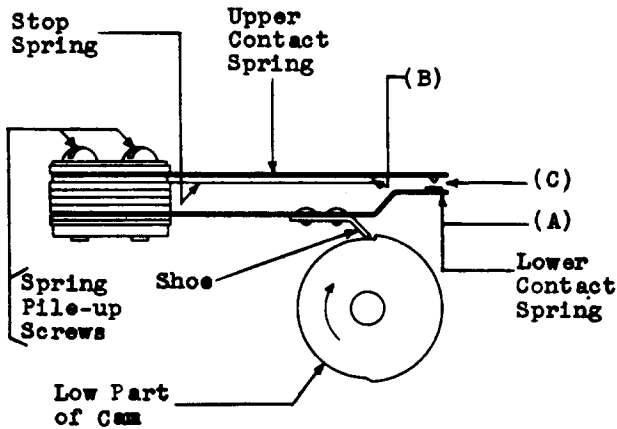

Fig. 5 - High-speed Cam Assembly — Method of Shoe Pressure and Contact Separation

2.14 Position of Upper Contact Spring:

Fig. 5(B) — With the shoe of the lower contact spring on the *low* part of the cam, the upper contact spring shall rest on the stop spring, at least at the free end of the stop spring.

Gauge by eye.

2.15 Contact Pressure: Fig. 6(A) — With the shoe of the lower contact spring on the *high* part of the cam, the contact pressure between the upper and lower springs measured at the end of the upper spring shall be

Test	Min 15 grams	Max 35 grams
Readjust	Min 20 grams	Max 30 grams

Use the 70D gauge.

2.16 Contact Separation: Fig. 5(C) — With the shoe of the lower contact spring on the *low* part of the cam, the separation between the contacts of the upper and lower springs shall be

Test	Min 0.025 inch	Max 0.055 inch
Readjust	Min 0.030 inch	Max 0.050 inch

Use the 66D gauge.

2.17 End Play of Upper Gear Box Shaft:

Fig. 7(A) — (This requirement does not apply to new-type upper gear box but only to old type of upper gear box.) The shaft stub in the upper gear box shall have a perceptible end play.

Gauge by eye.

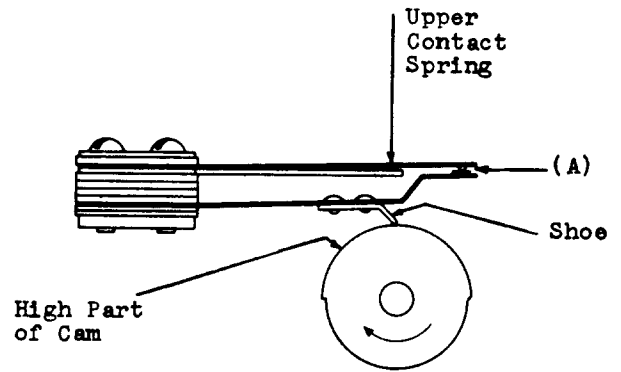

Fig. 6 - High-speed Cam Assembly — Method of Measuring Contact Pressure

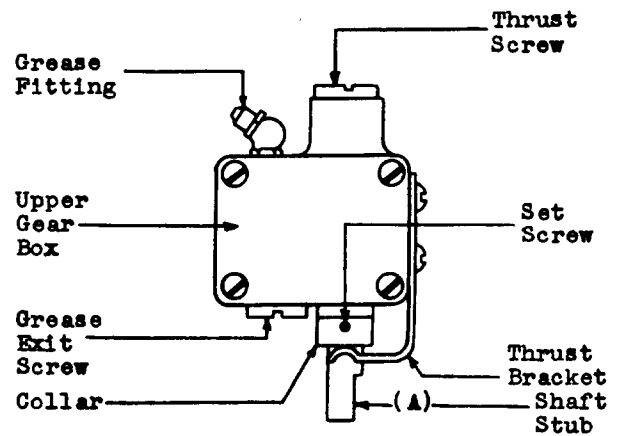

Fig. 7 - Upper Gear Box Showing Grease Fittings

To check this requirement, disconnect the coupling shaft from the motor generator at the bottom coupling and note the end movement of the coupling shaft while slightly rocking the SEC dial back and forth with the finger.

2.18 Switching Interval and Synchronization of Terminals

(a) With the coupling shaft disconnected from the motor generator at the top coupling on new panels (bottom coupling on older panels) and with left and right outer rocker arms positioned so that their associated pointers are at sector position "0," turn the shaft stub of the upper gear box (turn coupling shaft on older panels) manually and note that the TS and RS top contacts just break when the index coincides with the line

under the SEC dial position 40, as viewed from the opening in front of panel. Continue to turn shaft from this point for *exactly* 25 revolutions and note that at the end of the 25th revolution the TP and RP top contacts just break. This counting may be facilitated by placing pencil reference marks on the shaft stub and upper gear box (or, for older panels, on the coupling shaft and edge of cut-out in panels).

(b) The final position of the outer rocker arm pointers with respect to the sector is determined by the correct transmission time between terminals.

2.19 Relation Between Low- and High-speed Cams

(a) With the TS top contacts just breaking and the line under position 40 of the SEC dial appearing opposite the index in the window, the line under an odd number on the COMB dial shall be opposite its index.

(b) The low-speed cam contacts shall close and not close as indicated in Table A as the SEC and COMB dials are turned manually.

Gauge by ear using a test receiver connected across the contacts under test.

2.20 Timing of High-speed Cams: The length in seconds of the rise on the TP and RP or TS and RS cams shall be measured by rotating manually the SEC dial and noting the second of the rise and the second of the drop as indicated by the SEC dial. The difference is a measure of the length.

CAMS	TIME
TP and RP	14 ±4 seconds
TS and RS	25 ±3 seconds

Gauge by eye.

3. ADJUSTING PROCEDURES

3.001 List of Tools, Gauges, Materials, and Test Apparatus

CODE OR SPEC NO.	DESCRIPTION
TOOLS	
46	3/8-inch Hexagon Socket Wrench
245	3/8-inch and 7/16-inch Hexagon Open Double End Flat Offset Wrench
363	Spring Adjuster
486A	Oil Can
72003M	Spring Bender
D-156892	Spring Adjuster — Offset

TABLE A

LOW SPEED CAM SPRING	CONTACTS ARE NOT CLOSED WITH DIALS AT		CONTACTS ARE CLOSED WITH DIALS AT		CONTACTS ARE CLOSED WITH DIALS AT		CONTACTS ARE NOT CLOSED WITH DIALS AT	
	COMB DIAL POS	SEC DIAL POS	COMB DIAL POS	SEC DIAL POS	COMB DIAL POS	SEC DIAL POS	COMB DIAL POS	SEC DIAL POS
2	1	4	1	16	3	4	3	16
2	9	4	9	16	11	4	11	16
2	17	4	17	16	19	4	19	16
2	23	4	23	16	27	4	27	16
2	33	4	33	16	35	4	35	16
3	2	24	2	36	4	24	4	36
3	8	24	8	36	10	24	10	36
3	16	24	16	36	20	24	20	36
3	28	24	28	36	30	24	30	36
3	32	24	32	36	34	24	34	36
4	3	4	3	16	5	4	5	16
4	11	4	11	16	13	4	13	16
4	15	4	15	16	17	4	17	16
4	19	4	19	16	21	4	21	16
4	27	4	27	16	29	4	29	16
4	31	4	31	16	33	4	33	16
5	4	24	4	36	8	24	8	36
5	12	24	12	36	14	24	14	36
5	20	24	20	36	22	24	22	36
5	26	24	26	36	28	24	28	36
5	30	24	30	36	32	24	32	36
6	5	4	5	16	9	4	9	16
6	13	4	13	16	15	4	15	16
6	21	4	21	16	23	4	23	16
6	29	4	29	16	31	4	31	16
6	35	4	35	16	1	4	1	16
1	10	24	10	36	12	24	12	36
1	14	24	14	36	16	24	16	36
1	22	24	22	36	26	24	26	36
1	34	24	34	36	2	24	2	36

CODE OR SPEC NO.	DESCRIPTION
TOOLS	
D-156893	Spring Adjuster — Offset
D-156894	Spring Adjuster — Offset
D-156895	Spring Adjuster — Offset
D-156896	Spring Adjuster — Offset
D-156897	Spring Adjuster — Offset
KS-6320	Orange Stick
—	Lincoln Grease Gun No. 5958, Lincoln Engineering Co., St. Louis, Mo.
—	3-1/2 Inch Cabinet Screwdriver
—	4-inch Regular Screwdriver
—	6-inch Regular Screwdriver
—	Long Nose Pliers
—	Bristo Setscrew Wrench — 1/8 inch
GAUGES	
66D	Thickness Gauge Nest
70D	50-0-50 Gram Gauge
79C	0-200 Gram Push-Pull Tension Gauge
MATERIALS	
D-98063 or KS-2423	Cloth
KS-7470	Oil
KS-7860	Petroleum Spirits
—	Grease, MIL-G-3278A
—	Grease, Andok C — Standard Oil Company of New Jersey
—	General Electric Co. Ball Bearing Grease
TEST APPARATUS	
—	Test Receiver

3.002 General: While all the adjustments for the cam switching unit can be made with the unit mounted on the panel, it will facilitate work if the unit is removed, particularly in the case of a general overhauling of the unit.

Removing Cam Switching Unit from Panel

(1) Remove cover. Unsolder the leads from the terminal block, mounted on the cam assembly casting, and the leads to the low-speed cam springs.

(2) Disengage the coupling shaft from the motor generator as follows: Hold coupling shaft rigid with one hand at the same time grasping rubber coupling with the other hand and then pulling the rubber coupling down on the shaft. The holding of the shaft will prevent damage to the lower shaft coupling. Then loosen the setscrew at the bottom of the coupling shaft with the Bristo setscrew wrench and disengage the shaft from the lower gear box by pulling the shaft up. (On older models of the D-159393 panel the rubber coupling is the lower one and the spring coupling is at the top.) Remove the two rear mounting screws of the cam switching unit from the rear of the panel, and then while the unit is being supported in the rear, remove the remaining two mounting screws from the front of the panel. For the older type of panel, while the cam assembly unit is being supported in the rear, remove its four mounting screws from the front of the panel. Then pull the unit straight out. Use a 4-inch regular screwdriver.

Remounting Cam Switching Unit on Panel

(3) In remounting the unit on the panel, it is necessary that the proper relation be maintained between the high- and low-speed cams as covered in Reqt 2.18 and 2.19. This is obtained by having the dogs of the dog clutch engage the slot in the dial shaft coupling detail so that the line under position 40 of the SEC dial appears opposite the index in the SEC window and the line under any "odd" position of the COMB dial coincides as closely as possible with the index in the COMB window. With these two conditions met, press the unit towards the panel so that the dogs of the dog clutch engage the dial shaft coupling details and the locating pins engage the holes in the panel. With the unit in place and being held in place from the rear, remount the two mounting screws at the front of the panel and then the two mounting screws at the rear of the panel tightening them securely with the 4-inch regular screwdriver. For the older type

of panel, with the unit in place, remount the four mounting screws at the front of the panel tightening them securely with the 4-inch regular screwdriver. Then reconnect the leads to the terminal block and low-speed cam springs.

(4) Engage the coupling shaft to the lower gear box, tightening setscrew with the Bristo setscrew wrench. Then slip the top coupling up on the shaft so that the pin in the coupling engages the groove in the shaft stub protruding from the upper gear box. Slide the coupling up to approximately 1/8 inch from the gear box. For the older type panel the opposite should be done, as the rubber coupling is the lower one and the spring coupling is at the top.

3.01 *Cleaning* (Reqt 2.01)

(1) **General:** Remove loose material from the cam switching unit and from the cloth inside surfaces of the covers with a vacuum cleaner. Remove oily and greasy residue from accessible parts including metal inside surfaces of the covers by wiping with a D-98063 or KS-2423 cloth moistened with KS-7860 petroleum spirits. Follow this by wiping the parts with a clean dry D-98063 or KS-2423 cloth. The less accessible parts may be cleaned by using a clean D-98063 or KS-2423 cloth wrapped around the KS-6320 orange stick. Clean outside of covers and external parts of panel with a clean D-98063 or KS-2423 cloth.

(2) **Contacts:** Rotate the shaft in its normal operating direction until the contacts to be cleaned are open. Clean the contacts in accordance with approved procedures. Recheck Reqt 2.15 "Contact Pressure" and Reqt 2.16 "Contact Separation" after cleaning.

3.02 *Lubrication* (Reqt 2.02)

(1) **General:** In lubricating the unit, care should be exercised that excessive amounts of oil and grease are not applied. Excess oil may spread to nonlubricated parts and thus may affect the operation of the unit or associated equipment. Remove cover if necessary.

(2) **Lubrication Distinctions Between Old and New Design of Panels:** Since lubrication procedures differ for the old and new design

of D-159393 panels, the following points of difference are given for determining whether a particular panel to be lubricated is of the old or new design. (Some of the old panels may have been converted by modifications made on them in the field so that they have the lubrication features of the new design.)

Upper Gear Box: Old design had an oil cup; new design has a grease gun fitting and a grease exit hole screw.

Lower Gear Box: Old design had no oil cup (cover of gear box had to be removed for lubricating); new design has a grease gun fitting and a grease exit hole screw.

Motor Generator: On old design panel the motor generator had only one felt washer in each bearing; motor generator in new design panel has two felt washers in each bearing. A readily apparent distinction between old and new design (since the felt washers being enclosed are not visible) is in the mounting of the motor generator. On old design, each of the four rubber mounts is located directly in back of a mounting lug of the motor generator. On new design the motor generator is mounted on a set of brackets in an arrangement where the rubber mounting discs are located to one side of the mounting lugs of the motor generator. If, as a field modification, an extra washer has been installed in each bearing of the motor generator on old design of panel, it is suggested that some marking to indicate that this has been done be applied to the outside of the motor generator in a readily visible location.

(3) **Cam Shaft Bearings:** Using the 486A tool (oil can) apply 2 drops of KS-7470 oil to each of the five cam shaft bearing oil holes.

(4) **Differential Gear Assemblies — Bearings and Gear Teeth:** Using the 486A tool (oil can) apply KS-7470 oil liberally to each bearing and to the gear teeth. The small gears should be moved to and fro on the shafts to work the oil in.

(5) **Upper Gear Box Thrust Bracket:** Using the 486A tool (oil can) apply 2 drops of KS-7470 oil to the rubbing parts of the bracket.

Motor Generator Ball Bearings

(6) **New Motor Generators:** Remove oil hole plug at top of each bearing. Remove nozzle from the 486A tool (oil can) and using the oil can without the nozzle, apply 20 drops of KS-7470 oil to the oil hole. Remount the oil hole plug.

(7) **Old Motor Generators:** To reduce maintenance time and effort and to obtain improved lubrication for the bearings, it is recommended that an additional felt washer be installed for each bearing. Then after an initial lubrication of the bearings with Andok C grease or General Electric Company ball bearing grease, the routine lubrication will be simplified to applying 20 drops of KS-7470 oil in the hitherto unused top oil hole of each bearing. The felt washers should be ordered from the General Electric Company, Schenectady, New York, as "Felt Washers for Gear Box End of KS-5535 Multifrequency Motor Generator Set" and "Felt Washers for Fan End of KS-5535 Multifrequency Motor Generator Set," and the order should also give the information on the motor generator nameplate. One of each kind of these new felt washers is necessary as their inside diameters are different. These new felt washers should be soaked in KS-7470 oil before being installed. The procedures for installing the washers and for initial lubrication of the bearings with improved lubricant are covered in (8) through (16).

(8) Disengage coupling shaft from upper and lower gear boxes as described in 3.002(2).

(9) The motor generator end brackets should then be removed one at a time. ***In order to facilitate replacing each end bracket so as not to introduce bind, mark top position if not already marked.*** The procedure for removing the end brackets depends on whether or not equipment is mounted in the next bay adjacent to the end brackets. The following procedure assumes that the end bracket mounting screws are not accessible, due to adjacent mounted equipment.

(10) To remove gear box end bracket proceed as follows: Disconnect the plugs from the sockets of the two separable connectors located on back of motor generator. Remove motor generator mounting nuts with the 245 tool. Remove ground lead terminal from

upper left stud. Remove motor generator from panel and place on a workbench. Remove gear box cover screws with the 3-1/2 inch cabinet screwdriver. Grasp shaft stud protruding from cover and lift off cover. Remove gear box mounting screws using the 6-inch regular screwdriver and remove the gear box. Remove end bracket mounting screws with the 4-inch regular screwdriver. Work off end bracket, tapping it with the handle of the 3-1/2 inch cabinet screwdriver if necessary.

(11) With the gear box end bracket removed, remove the present felt washer (black), the oil impregnated felt washer (white), and the steel split washer. ***Be careful to note the location of each part so that they can be re-assembled in the proper sequence.*** Scrape out the old grease from the bearings and from the grease recess in the end bracket with the KS-6320 orange stick. This will leave some old grease in the machine which will do no harm. ***Do not use a cloth or liquid solvent to remove grease.*** Remove old grease from felt washers and steel split washer. Soak the old impregnated washer (white) in KS-7470 oil. ***Fill old ball bearing or new replacement ball bearing*** flush with raceway 2/3 full with Andok C grease or General Electric Company ball bearing grease. Fill grease recess in end bracket 2/3 full. ***The utmost care should be taken to avoid getting any dust or dirt into bearings and recess. Never fill grease recess in end bracket entirely full as free space is essential to prevent friction on bearing retainers. Do not remove ball bearings from the shaft.*** Reassemble washers in reverse order found on disassembly. The steel split washer is remounted next to the ball bearing. Then place the new or old oil impregnated washer (white) saturated with KS-7470 oil next to the steel washer and then the old felt washer (black) also saturated with KS-7470 oil next to that.

(12) Replace gear box end bracket as follows:

Slip on gear box end bracket, top side up, so oil hole is vertical. Insert end bracket mounting screws and tighten each in turn slightly until all are secure using the 4-inch regular screwdriver. Turn shaft manually and check for bind by feel and listening for a scraping sound. If end bracket has not been placed on in original position there may be

bind. Remount gear box. Insert gear box mounting screws and tighten securely with the 6-inch regular screwdriver. Remount gear box cover positioning it so shaft bearing is properly aligned as indicated by free rotation, and end play not to exceed 0.020 inch as gauged by eye.

(13) To remove the end bracket on the fan end proceed as follows: Remove the fan mounting setscrew with the 3-1/2 inch cabinet screwdriver and slip off the fan. Remove the end bracket mounting nuts with the 46 tool. ***In order to facilitate replacing the end bracket so as not to introduce bind, mark the top position if not already marked.*** After this, work off the end bracket, tapping it with the handle of the 3-1/2 inch cabinet screwdriver, if necessary.

(14) With the end bracket at the far end removed, remove the present felt washer (black), the oil impregnated washer (white), steel split washer, the steel shim washers (if used), and the steel spring washer. ***Be careful to note the exact location of each part so that they can be reassembled in the proper sequence.*** Scrape out the old grease from the bearings and from the grease recess in the end bracket with the KS-6320 orange stick. This will leave some old grease in the machine which will do not harm. ***Do not use a cloth or liquid solvent to remove grease.*** Remove old grease from all felt and steel washers. Soak the oil impregnated washer (white) in KS-7470 oil. ***Fill old ball bearing or new replacement ball bearing*** flush with raceway 2/3 full with Andok C grease or General Electric Company ball bearing grease. Fill grease recess in end bracket 2/3 full. ***The utmost care should be taken to avoid getting any dust or dirt into bearing and recess. Never fill grease recess in end bracket entirely, as free space is essential to prevent friction on bearing retainers. Do not remove ball bearings from shaft.*** Reassemble washer in the reverse order found on disassembly. The steel spring washer is mounted next to the ball bearing; the steel shim washers (when used) are assembled next; the steel split washer is added; then place the oil impregnated washer (white) saturated with KS-7470 oil in place next to the steel washer; and finally place the old felt washer (black) also saturated with KS-7470 oil next to that.

(15) To replace the end bracket on the fan end proceed as follows: Slip on the end bracket, with the top side up, so that the oil hole will be vertical. Remount the end bracket mounting nuts, tightening each in turn slightly until all are secure, using the 46 tool. Turn the shaft and check for bind by feel and listening for a scraping sound. If the end bracket has not been placed in its original position, bind may be introduced. Remount the fan, pushing it on the shaft as far as possible. This provides the proper clearance between the fan and the soundproofing material in the motor generator can cover. Insert the fan mounting setscrew and tighten securely with the 3-1/2 inch cabinet screwdriver. After the extra felt washer has been installed in each bearing of the motor generator on old design of panel, it is suggested that some marking to indicate that this has been done be applied to the outside of the motor generator in a readily visible location.

(16) Remount the motor generator on the panel. Replace the ground lead terminal on the upper left stud. Replace the motor generator mounting nuts, tightening them securely with the 245 tool. Re-engage the coupling shaft to upper and lower gear boxes as covered in 3.002(4). Reconnect the plugs to the sockets of the two separable connectors located on the back of the motor generator.

(17) After extra felt washers have been added as above, for routine lubrication after a 6-month interval, proceed as in 3.02(6).

→ (18) ***Cams:*** Apply a thin film of the MIL-G-3278A grease evenly over entire cam contacting surface with finger. Remove excess lubricant from sides of cam and rear portion of cam shoe with the blade of the 3-1/2 inch cabinet screwdriver. After the unit has been operating, repeat removal of excess lubricant, if necessary.

Upper and Lower Gear Boxes

New and Modified Gear Boxes

(19) ***Initial Lubrication:*** At time of installation of new gear boxes (which are shipped from factory without any lubricant in them), and at time of changeover to improved lubricant (MIL-G-3278A grease) for

old gear boxes that have been modified, the initial lubrication should be done as follows: Disconnect coupling shaft from upper and lower gear boxes as described in 3.002(2). Remove gear box cover screws with the 3-1/2 inch cabinet screwdriver and remove covers and cover gaskets. On lower gear box, lift up the cover by grasping the shaft stub protruding through the cover and pulling up. Remove all old grease from the gear boxes with a KS-6320 orange stick. For new gear boxes (shipped from factory without lubricant) make a visual inspection to check that there are no chips or metal particles in them. Remount the cover gaskets and cover plates. (When remounting the cover on an *old-type* lower gear box, care should be taken in regard to its position so that the shaft bearing in the cover is properly aligned. Correct shaft alignment is indicated by free rotation, and end play not to exceed 0.020 inch as gauged by eye.) Re-engage coupling shaft to upper and lower gear boxes as described in 3.002(4). Before motor is run, insert grease exit hole screw in place and loosen one of the cover screws on the side of the gear box opposite the grease gun fitting 1 turn. Apply MIL-G-3278A grease through the grease fitting with the 5958 Lincoln grease gun until the gear box is full, as indicated by a slight discharge of grease escaping around the loosened cover box screw or around the coupling shaft bearings. Tighten the loosened cover box screw. Wipe any excess grease extruded from the gear box, and *remove the grease exit hole screw* to allow excess grease to escape from the gear box. Wipe excess grease from the grease exit hole and run motor for 1 hour to allow for grease expansion. Wipe excess grease from around grease exit hole and remount grease exit hole screw.

(20) **Routine Lubrication:** Before applying any grease, loosen one of the cover box screws on the side of the gear box opposite the grease gun fitting approximately 1 turn, and apply MIL-G-3278A grease through grease fitting with the 5958 Lincoln grease gun until a slight amount of old grease is extruded from around the coupling shaft bearings or between the gear box and its loosened cover screw. Wipe off any excess grease, tighten grease box cover screw, and *remove grease exit hole screw*. Run motor for 1 hour to allow for

grease expansion. Wipe excess grease from exit hole and remount grease exit hole screw. Every 5 years, all old grease should be *cleaned out* of the gear boxes and new grease added as described in 3.02(19).

Old Gear Boxes Not Modified

(21) **Initial Lubrication:** The initial lubrication with improved lubricant (MIL-G-3278A grease) for old gear boxes that have not been modified should be done as follows: Disconnect coupling shaft from upper and lower gear boxes as described in 3.002(2). Have ready a suitable container for catching the used oil that will run out from the upper gear box when the next step is performed. Remove gear box cover screws with the 3-1/2 inch cabinet screwdriver and remove covers and cover gaskets. On lower gear box lift up the cover by grasping the shaft stub protruding through the cover and pulling up. Remove the used oil from the lower gear box by soaking it up with a D-98063 or KS-2423 cloth. After the oil has been removed, swab the inside of the gear boxes dry with a clean piece of cloth. Fill gear boxes 2/3 full with MIL-G-3278A grease. Remount cover gaskets and covers. (When remounting the cover on the lower gear box, care should be taken in regard to its position so that the shaft bearing in the cover is properly aligned. Correct shaft alignment is indicated by free rotation, and end play not to exceed 0.020 inch as gauged by eye.) Re-engage coupling shaft to upper and lower gear boxes as described in 3.002(4).

(22) **Routine Lubrication:** The routine lubrication with improved lubricant (MIL-G-3278A grease) for old gear boxes that have not been modified should be done as follows: Disconnect coupling shaft from upper and lower gear boxes as described in 3.002(2). Remove gear box cover screws with the 3-1/2 inch cabinet screwdriver and remove covers and cover gaskets. On lower gear box lift up the cover by grasping the shaft stub protruding through the cover and lifting up. Remove old grease with the KS-6320 orange stick. Fill gear boxes 2/3 full with new MIL-G-3278A grease. Remount cover gaskets and covers. (When remounting the cover on the lower gear box, care should be taken in regard to its position so that the shaft bearing in the cover is

properly aligned. Correct shaft alignment is indicated by free rotation, and end play not to exceed 0.020 inch as gauged by eye.) Re-engage coupling shaft to upper and lower gear boxes as described in 3.002(4).

3.03 Record of Lubrication (Reqt 2.03)

No procedure.

3.04 Alignment of Coupling Shaft with Gear Box Shafts (Reqt 2.04)

- (1) To align the shafts, loosen the screws that fasten the lower gear box assembly to the motor generator end bracket and the screw that clamps the upper gear box to the driven shaft and then rotate the upper and lower gear box assemblies. Tighten the screws securely. Use the 6-inch regular screwdriver on the lower gear box mounting screws and the 4-inch regular screwdriver on the upper gear box clamping screw.

Low-speed Cam Spring Assemblies
(3.05 through 3.10)

3.05 Relation Between Cam and Cam Shoe
(Reqt 2.05)

3.06 Contact Alignment (Reqt 2.06)

- (1) To adjust to meet these requirements, loosen the spring pile-up screws with the 3-1/2 inch cabinet screwdriver and shift the springs as required. Retighten the screws securely.

3.07 Pressure of Cam Shoe on Cam (Reqt 2.07)

- (1) To increase the pressure of the cam shoe on the cam, insert the narrow side of the 72003M spring bender between the springs. With the straight side resting on the pile-up insulators, twist the spring bender so that the inner spring is forced against the cam.
- (2) To decrease the pressure, place the hook of the 72003M spring bender over the top of the inner spring and carefully pull the spring away from the cam.
- (3) Recheck Reqt 2.15 "Contact Pressure" and Reqt 2.16 "Contact Separation" after this adjustment.

3.08 Position of Outer Contact Spring
(Reqt 2.08)

- (1) To position the contact springs on the stop spring, use the 363 tool or D-156896 and D-156897 spring adjusters as required. Apply the spring adjuster to the contact spring near the free end of the stop spring and twist the spring adjuster so as to force the contact spring against the stop spring.
- (2) Recheck Reqt 2.15 "Contact Pressure" and Reqt 2.16 "Contact Separation" after this adjustment.

3.09 Contact Separation (Reqt 2.09)

- (1) To increase the separation insert the narrow side of the 72003M spring bender between the springs. With the straight side resting on the pile-up insulators, twist the spring bender so as to force the outer spring away from the inner spring.
- (2) To decrease the separation, if it is not more than 0.010 inch outside the limit, apply the D-156896 and D-156897 spring adjusters to the bent portion of the spring, just where it leaves the straight portion, and twist the spring adjusters so as to force the tip of the spring nearer the inner spring. If the separation is more than 0.010 inch outside the limit, remove the outer spring from the pile-up and adjust the stop spring and outer spring with the long nose pliers. Use the 3-1/2 inch cabinet screwdriver to remove and remount the spring pile-up screws.
- (3) Recheck Reqt 2.15 "Contact Pressure" after this adjustment.

3.10 Contact Pressure (Reqt 2.10)

- (1) To decrease the pressure, increase the contact separation as covered in 3.09 or decrease the tension of the outer spring on the stop spring. It is, in general, preferable to reduce the tension of the outer springs since keeping the separation nearer the lower limit provides for more contact wear before readjustment to meet the separation requirement becomes necessary, especially since it is difficult to reduce the separation. Reduce the tension by lifting the outer spring off the top spring with the finger.

High-speed Cam Spring Assemblies (3.11 through 3.16)

3.11 *Relation Between Cam and Cam Shoe* (Reqt 2.11)

3.12 *Contact Alignment* (Reqt 2.12)

- (1) To adjust to meet these requirements, loosen the spring assembly pile-up screws with the 3-1/2 inch cabinet screwdriver and shift the springs as required. Retighten the screws securely.

3.13 *Pressure of Cam Shoe on Cam* (Reqt 2.13)

- (1) To adjust for pressure, use the D-156894 and D-156895 spring adjusters. Apply the spring adjusters to the lower contact spring near where it leaves the spring pile-up and twist up or down as required.

3.14 *Position of Upper Contact Spring* (Reqt 2.14)

3.15 *Contact Pressure* (Reqt 2.15)

- (1) To position the stop spring and adjust the contact pressure, loosen the spring pile-up screws with the 3-1/2 inch cabinet screwdriver. Adjust the upper contact spring for pressure in excess of that required and the stop spring so that when the pile-up screws are tightened, the upper contact spring will rest on the stop spring. Use the D-156894 and D-156895 spring adjusters. Check contact pressure and if too high, reduce by adjusting the upper spring and stop spring up, using the D-156892 and D-156893 spring adjusters. This should be done very carefully since otherwise the pressure may be reduced too much.

3.16 *Contact Separation* (Reqt 2.16)

- (1) To change the contact separation, carefully adjust the upper contact spring and associated stop spring up or down as required. Recheck the upper contact spring and contact pressure requirements (2.14 and 2.15).

3.17 *End Play of Upper Gear Box Shaft* (Reqt 2.17)

- (1) (This does not apply to new-type upper gear box but only to old type.) To correct the end play, disconnect the coupling shaft from the bottom and top gear boxes as covered in 3.002(2). Then loosen the clamping screw

which clamps the top gear box to the switching unit casting, using the 4-inch regular screwdriver. Rotate top gear box so that the shaft stub is brought forward, making the setscrew in the gear box collar accessible. **Exercise care not to snag the high-speed cam springs on the cams.** Loosen the setscrew in the collar with the Bristo setscrew wrench. While forcing the shaft stub up against the thrust screw in the top of the gear box, pull the collar down against the thrust bracket. Then while holding the collar against the bracket, tighten the setscrew securely. Recheck requirement, observing for end movement of the shaft stub. Repeat adjustment, if necessary. Rotate gear box back in place, **exercising care not to snag the high-speed cam springs on the cams.** Tighten the clamp screw securely. Reconnect the coupling shaft as covered in 3.002(4).

3.18 *Switching Interval and Synchronization of Terminals* (Reqt 2.18)

- (1) If the TS and RS top contacts do not just break when the index coincides with the line under SEC dial position 40, loosen the setscrew in the brass collars of the TS and RS cams with the Bristo setscrew wrench and reposition the cams until the requirement is met. Then tighten the setscrew securely.

- (2) If the TP and RP contacts do not just break at the **exact** end of the 25th revolution of the shaft, loosen the inner rocker arm clamping screw and turn the inner rocker arm adjusting screw with the fingers until the requirement is met. This is a very critical adjustment and unless it is made exactly, difficulty will be experienced in making final correction at the time of over-all system line-up test for "Equal Switching Interval."

- (3) The adjustment of the outer rocker arm is determined by the transmission time between terminals and is called "Synchronization of Terminals." This adjustment is made in accordance with other instructions at the time of over-all system tests.

3.19 *Relation Between Low- and High-speed Cams* (Reqt 2.19)

3.20 *Timing of High-speed Cams* (Reqt 2.20)

- (1) If these requirements are not met, the unit should be returned to the factory.

SECTION 030-767-701

REASONS FOR REISSUE

1. To change the type of grease [2.02(b), 3.001, and 3.02(18) through (22)].
2. To revise the procedure for assembling the gear box end of the motor generator bearings [3.02(11)].
3. To revise the procedure for assembling the far end of the motor generator bearings [3.02(14)].
4. To revise the procedure for lubricating the lower gear boxes [3.02(19)].
5. To revise the procedure for lubricating the upper gear boxes [3.02(20)].