

MOTOR-DRIVEN SWITCHES

KS-15847 TYPE

REPLACEMENT PARTS AND PROCEDURES

1. GENERAL

1.01 This section covers the information necessary for ordering parts to be used in the maintenance of the KS-15847 type motor-driven switches. It also covers approved procedures for replacing these parts.

1.02 This section is reissued to include information on manual crank and protective cover for the KS-15847 motor-driven switches.

1.03 Part 2 of this section covers ordering information for those parts which it is practicable to replace in the field in the maintenance of these switches. No attempt should be made to replace parts not designated except small items such as screws. Part 2 also contains an explanatory figure showing the different parts. This information is called Replacement Parts.

1.04 Part 3 of this section covers the approved procedures for the replacement of the parts covered in Part 2. This information is called Replacement Procedures.

Caution 1: Before doing any work on the switch, remove the ECM and VR fuses on the main control panel of the associated plant to remove voltage from the motor and motor control circuit thus preventing automatic operation of the switch.

Caution 2: When working on the switch, extreme care should be taken to prevent shorting between the live contacts and other metal parts of the switch.

2. REPLACEMENT PARTS

2.01 The figure included in this part shows the various replacement parts, with their corresponding names, in their proper relation to other parts of the apparatus.

2.02 When ordering a replacement part, give the name of the part and the complete nameplate data of the switch, including the KS number, list number, manufacturer's name and serial number. For example: L relay for KS-15847, L1 Switch, Albert and J. M. Anderson Mfg Co., Serial (number).

2.03 Information enclosed by parentheses () is not ordering information. This information may be references to notes, parts referred to in other portions of the section and not considered replaceable, or part names in general use in the field if these names differ from those assigned by the manufacturer.

2.04 Two improvements have been made on new KS-15847 motor-driven switches. Modification kits to apply these improvements to existing switches are as follows:◆

(a) ◆A manual crank to replace the setscrew and open-end wrench arrangement for manual emergency operation (Fig. 1). It is recommended the manual crank be installed on all existing KS-15847 switches. The modification kit includes all hardware, installation instructions, and a new emergency operation instruction plate. The modification kit is coded as follows:◆

Switch	Volts
KS-15847 L201	24
KS-15847 L202	48
KS-15847 L203	130

(b) ◆A cover (Fig. 2) for the KS-15947 switch to prevent accidental contact with switch parts and to exclude dust. It is recommended the cover be installed on all existing KS-15847 switches. The modification kit includes all hardware and installation instructions. The modification kit is coded as follows:◆

Switch	Amperes
KS-15847 L101	1000
KS-15847 L102	2000

SECTION 030-786-801

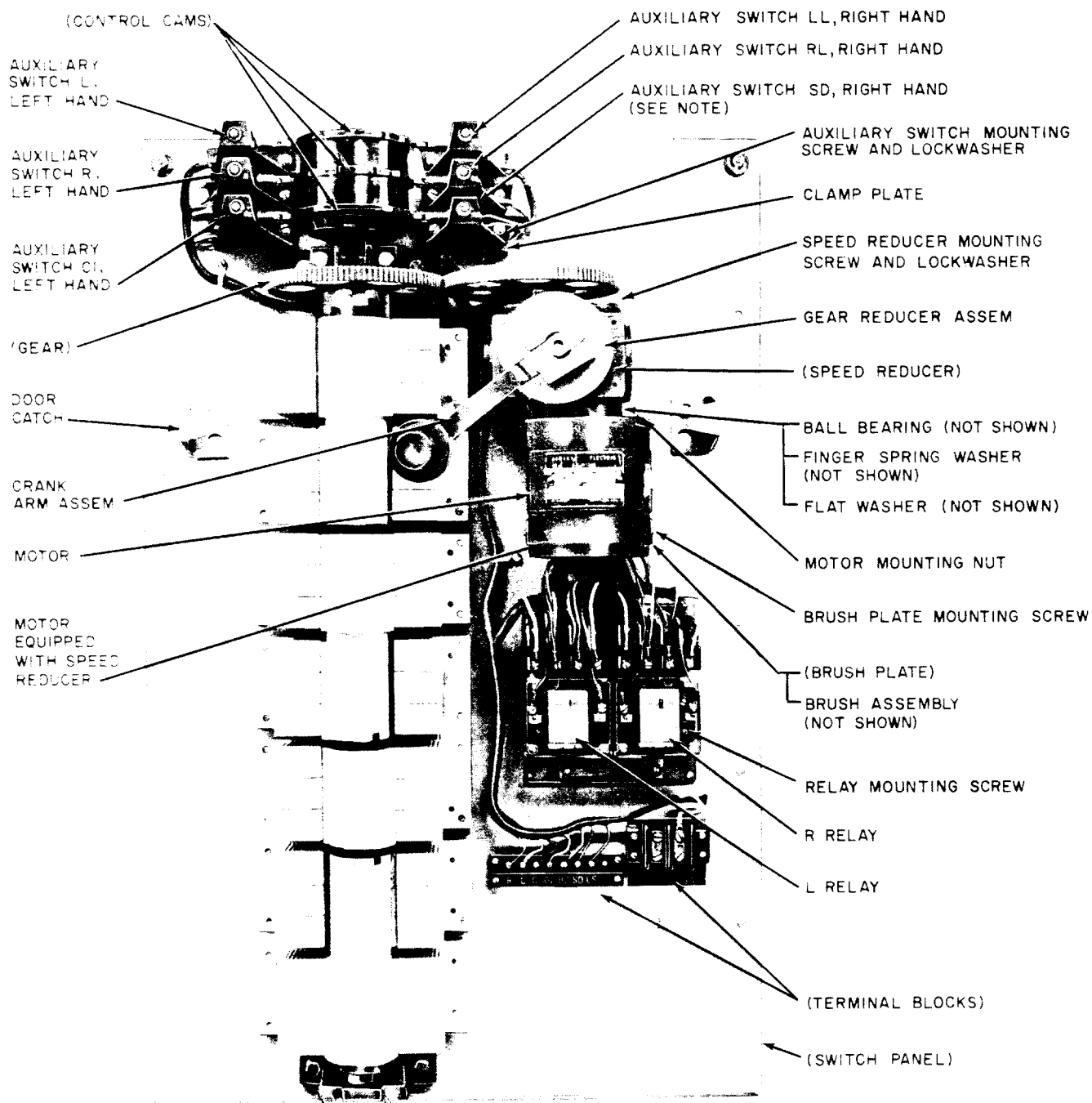

NOTE

AUXILIARY SWITCH SD IS FURNISHED ON KS-15847, L4 TO 6 AND L11 TO 13 ONLY.

Fig. 1—KS-15847 Type Switch with Crank for Manual Emergency Operation (front view)



Fig. 2—Cover for KS-15847 Type Switch (rear view)

3. REPLACEMENT PROCEDURES**3.01 List of Tools and Material**

CODE OR SPEC NO.	DESCRIPTION
TOOLS	
245	3/8- and 7/16-Inch Hex Open Double-End Wrench
R-1324	Screwdriver
R-1512	Adjustable Wrench
R-1542	Adjustable Wrench
R-3094, Detail 2	Handle
R-3094, Detail 5	Extension
R-3094, Detail 8	Universal Joint
R-3094, Detail 17	7 16-Inch Socket Wrench
D-160806	Bearing Puller
—	4-Inch E Screwdriver
—	4-Ounce Riveting Hammer
—	1/4-Inch Allen Wrench (furnished with switch)
MATERIALS	
KS-6232	Light Mineral Oil
KS-14666	Cloth
—	1/4-Inch Diameter Brass Rod, Approximately 4 Inches Long
—	Brass or Copper Tubing [see 3.07 (d)]

3.02 Before making any replacement of parts, make sure that the switch is in a position to ensure maintenance of the required office voltage.

3.03 After making any replacement of parts, the part or parts replaced shall meet the requirements involved as specified in Section 030-786-701. Other parts whose adjustments may have been disturbed by the replacing operations shall also meet the requirements and an over-all operation check shall be made before restoring the switch to service.

Motor Equipped With Speed Reducer Fig. 1 and 3

3.04 In order to facilitate replacement of the motor, the motor and speed reducer are replaced as a unit as covered in 3.05 and 3.06.

3.05 Removing Motor and Speed Reducer

- (1) If a cover is provided for the gears above the speed reducer, remove the cover mounting screws using the 4-inch E screwdriver and remove the cover.
- (2) Using the 4-inch E screwdriver, disconnect the motor leads from the relay and terminal block.
- (3) Before removing the motor and speed reducer from the switch panel, mark the gears to ensure meshing of the same teeth when mounting the new motor and speed reducer. Then using the R-3094, Detail 17 socket wrench with the R-3094, Detail 8 universal joint, R-3094, Detail 5 extension, and R-3094, Detail 2 handle, remove the four speed reducer mounting screws and lockwashers and remove the speed reducer with motor from the switch panel. Place the speed reducer with the motor on a work bench. Remove the setscrew in the hexagonal shoulder on the speed reducer gear using the Allen wrench furnished with the switch for a socket head screw or the R-1542 adjustable wrench for a hexagonal head screw, and remove the gear.

3.06 Mounting Motor and Speed Reducer

- (1) Mount the new motor and speed reducer on the switch panel, but do not tighten the mounting screws. Position the gear on the shaft of the speed reducer so the marks on both gears are in line. Make sure that the gears mesh freely and then securely tighten the speed reducer mounting screws. Connect the motor leads to the proper terminals on the relay and terminal block, referring to Fig. 5 and the designations on the leads.

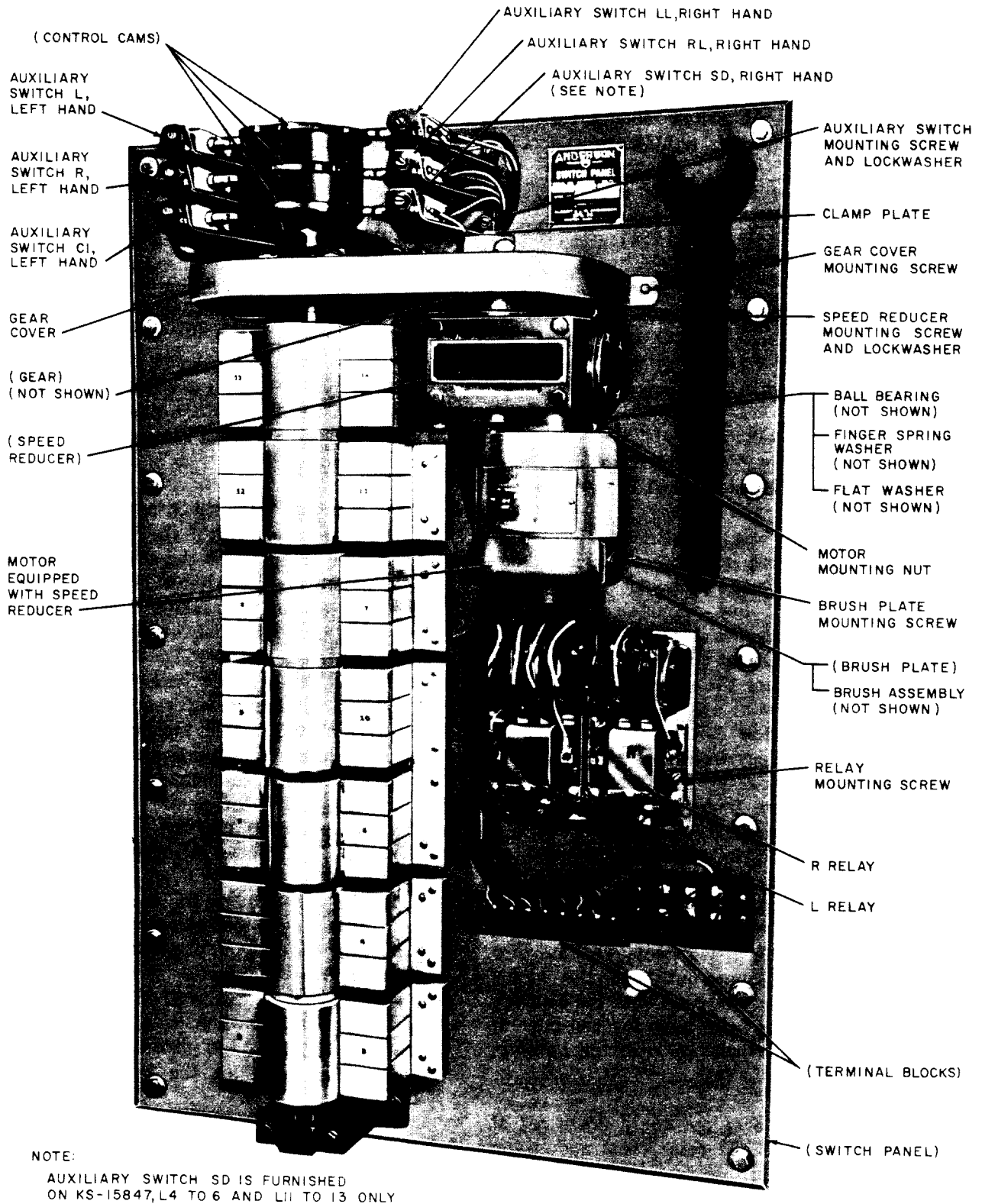

Fig. 3—KS-15847 Type Switch (Manufacture Discontinued) with Wrench for Manual Emergency Operation

(2) Reinstall the ECM and VR fuses on the contro. panel of the associated plant. Line up the setscrew hole in the gear with the hole in the speed reducer shaft by manually operating the L or R side of the switch relay to turn the shaft. Mount and securely tighten the setscrew.

(3) Remount the gear cover, if provided, and securely tighten the screws.

Ball Bearings

3.07 If the motor has been in service for several years, it is recommended that both ball bearings be replaced whenever it is necessary to replace one. To replace a bearing, proceed as follows.

(1) Remove the motor and speed reducer from the switch panel as covered in 3.05.

(2) Remove both brush assemblies from the motor as covered in 3.08(1), marking them for remounting in their original positions.

(3) Using the 245 open-end wrench, remove the two motor mounting nuts on the motor end plate which is part of the speed reducer. Hold the speed reducer with one hand, and with the other hand grasp the motor housing and pull the motor straight out from the speed reducer. Take care not to lose the Woodruff key in the motor shaft and the finger spring washer and flat washer associated with the motor bearing. The washers may come out with the shaft or remain in the bearing housing in the end plate on the speed reducer. Examine the washers and replace them, if necessary. When pulling the motor from the speed reducer, the rotor may or may not come out with the motor housing. If the rotor comes out with the housing, carefully remove the rotor from the housing. If the rotor does not come out with the housing, proceed as covered in (4).

(4) Position one end of the 4-inch brass rod at the free end of the rotor shaft and, using the 4-ounce riveting hammer, gently tap the rod several times. This should free the inner end of the rotor shaft. Then, while holding the speed reducer, firmly grasp the rotor and pull the rotor from the speed reducer. If the rotor shaft is still not free, again tap the shaft and repeat the procedure. Take care not to lose

the Woodruff key, finger spring washer, and the flat washer.

(5) Using the D-160806 bearing puller, remove the defective bearing, or both bearings if both are being replaced.

(6) Wipe the shaft with a clean KS-14666 cloth. Start the new bearing on the shaft. Then position the tube which just fits over the shaft so that it engages the inner race of the bearing. Using the 4-ounce riveting hammer, gently tap the tube to position the bearing on the shaft.

(7) Wipe the inside of the bearing housing in the motor and in the motor end plate on the speed reducer with a clean KS-14666 cloth moistened with a small amount of KS-6232 light mineral oil.

(8) Place the flat washer against the shoulder of the inner end of the bearing housing in the motor end plate on the speed reducer. With the fingers of the finger spring washer toward the open end of the housing, position the spring washer against the flat washer.

(9) Look through the hole in the motor end plate on the speed reducer and note the position of the slot in the gear just inside the speed reducer. Position the key end of the rotor shaft so that the key lines up with the gear slot. Carefully insert the shaft into the gear with the key engaging the slot, taking care not to dislodge the washers in the bearing housing.

(10) Position the motor housing so that the mounting studs line up with their associated holes in the motor end plate on the speed reducer, and the motor nameplate will be at the front when the speed reducer and motor are mounted on the switch panel. Carefully mount the housing on the end plate and securely tighten the nuts. Remount the brush assemblies as covered in 3.08(2).

(11) Mount the motor and speed reducer on the switch panel as covered in 3.06

Brush Assembly

3.08 To replace a brush assembly, proceed as follows.

- (1) Using the 4-inch E screwdriver, remove the brush plate mounting screws and remove the brush plate. Then remove the brush assembly from the brush holder.
- (2) Position the new brush assembly in the brush holder with the brush spring outermost. Carefully compress the spring and remount the brush plate, securely tightening the screws.

Auxiliary Switches

3.09 The auxiliary switch includes the mounting bracket which is permanently secured to it. To replace an auxiliary switch, proceed as follows.

- (1) Tag the leads to the auxiliary switch terminals for connection to the corresponding terminals on the new switch. Using the 4-inch E screwdriver, disconnect the leads from the switch. Taking care not to drop the clamp plate that is mounted under the lockwashers, remove the auxiliary switch mounting screws and lockwashers, using the R-1324 screwdriver and remove the clamp plate and auxiliary switch.
- (2) Position the new auxiliary switch on the switch panel so that the switch-actuating roller engages its associated control cam and the mounting holes in the switch line up with the associated holes in the panel. With the lockwashers and clamp plate on the screws, securely tighten the screws. Connect the leads to the proper terminals on the switch and securely tighten the terminal screws.

Relay

3.10 To replace the L or R relay, proceed as follows:

- (1) Tag the leads to the relay terminals for connection to the corresponding terminals

on the new relay. Using the 4-inch E screwdriver, disconnect the leads from the relay terminals. Loosen the mounting screws securing the lower end of the relay. Remove the mounting screw and lockwasher securing the top of the relay. Lift the relay from the lower screws and remove the relay.

- (2) Mount the new relay on the switch panel and securely tighten the screws. Connect the leads to the proper terminals on the relay and securely tighten the terminal screws.

Current-Limiting Resistors: Fig. 4

- 3.11** Before replacing a current-limiting resistor make sure the switch is in the NOR position.

Caution: *Exercise extreme care to avoid shorting live parts with the tools or hands. Before doing any work on the rear of the switch, wrap live parts with canvas or tape as required to avoid possible short circuits or shock.*

- (1) Using the R-1542 and R-1512 adjustable wrenches, remove the resistor mounting screws, lockwashers, and nuts and remove the resistor.
- (2) Mount the new resistor and securely tighten the nuts.

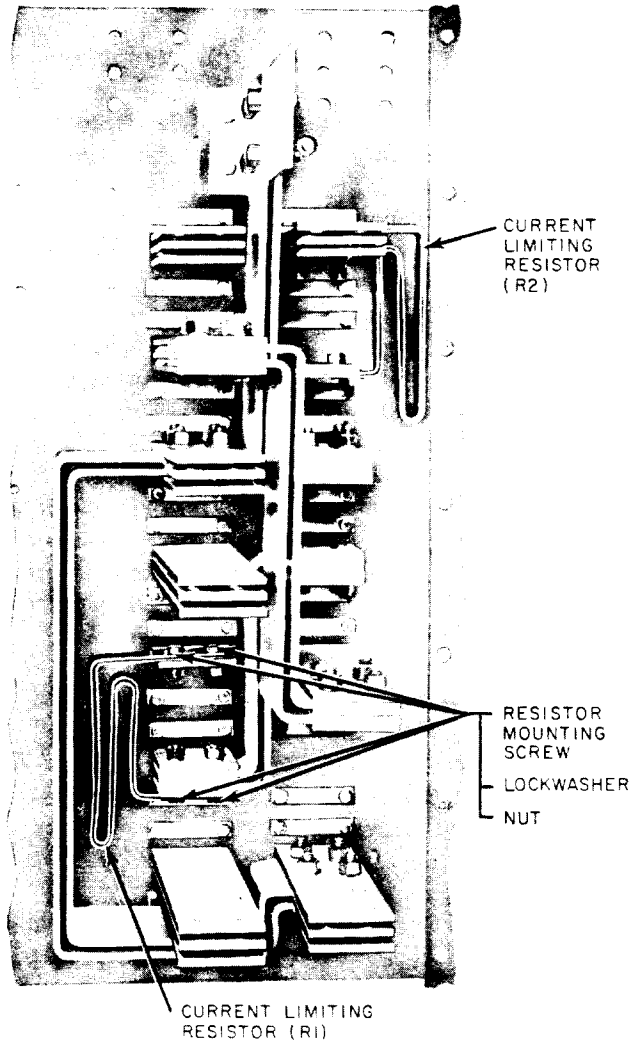
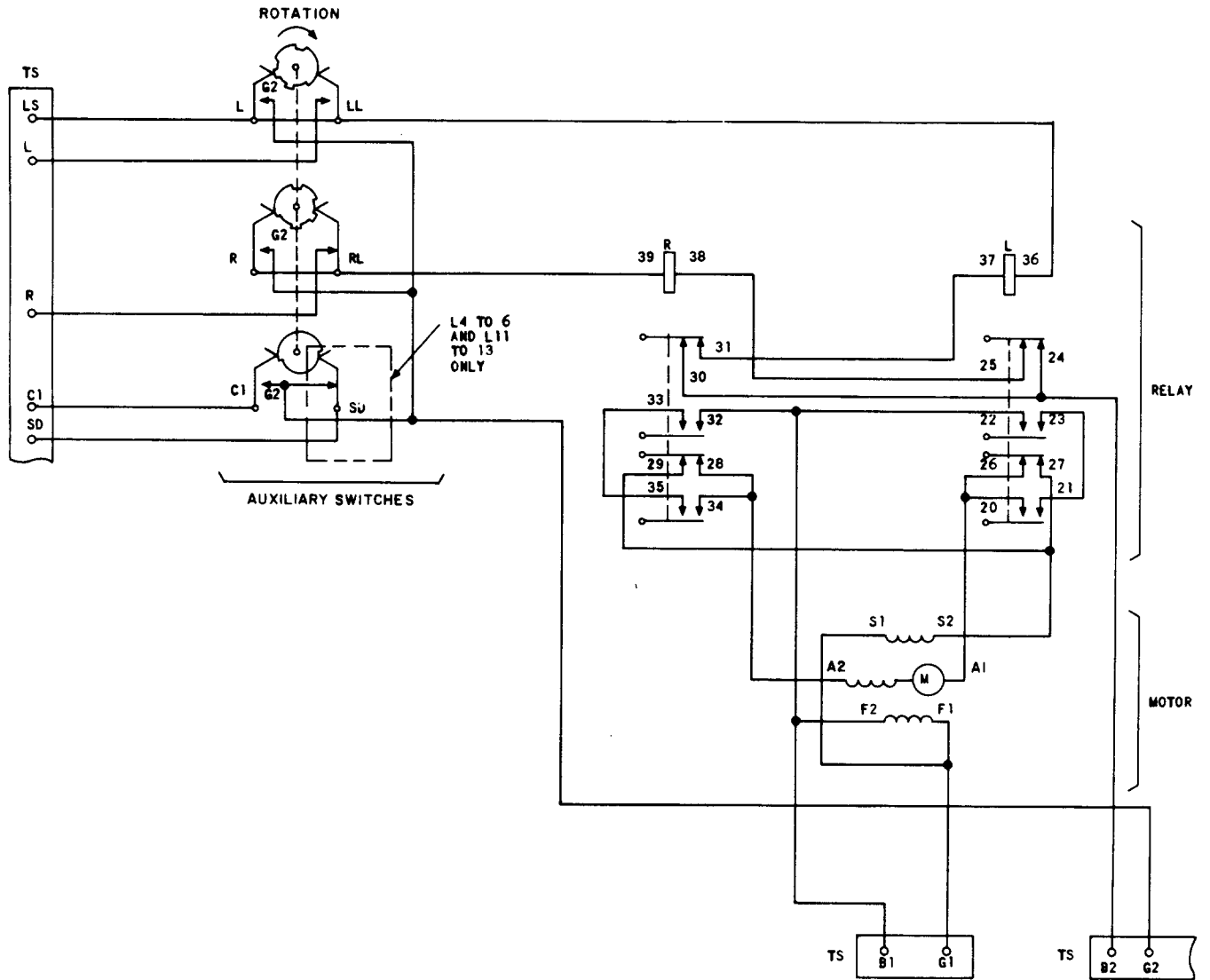

Fig. 4—KS-15847 Type Switch (partial rear view)



◆ Fig. 5—Schematic Showing Wiring Connections for Motor Relay, and Auxiliary Switches (switch in NOR position) ◆