

JACKS

NO. 463A

REQUIREMENTS AND ADJUSTING PROCEDURES

1. GENERAL

1.01 This section covers the No. 463A jack used as the test jack on step-by-step system circuits.

1.02 Reference shall be made to Section 020-010-711 covering general requirements and definitions for additional information necessary for the proper application of the requirements listed herein.

2. REQUIREMENTS

2.01 Cleaning: The contacts shall be cleaned when necessary in accordance with the section covering cleaning of relay contacts and parts.

2.02 Contact Alignment:

(a) Fig. 1 (A): The contacts shall line up so that the width of the contacting surface of each contact bar falls wholly within the length of its mating bar. Gauge by eye.

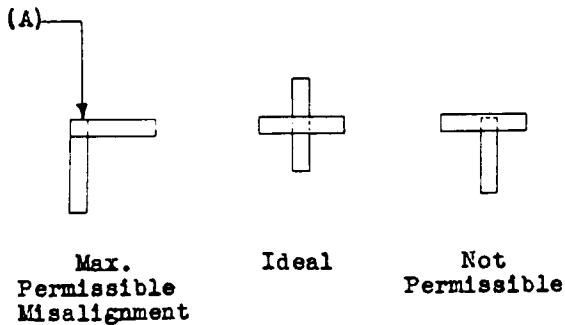

Fig. 1 - Alignment of Contacts - Plan View of Contacting Surfaces

2.03 Contact Pressure:

(a) With no plug inserted into the jack the pressure between springs 6 and 7 shall be

Test - Min. 60 grams

Readj. - Min. 70 grams

Apply the tip of the No. 68C gram gauge to spring 6 at a point just in front of the contacts.

(b) With the No. 240B plug or its equivalent inserted into the jack the contact pressure between the Nos. 5 and 6 springs shall be

Test - Min. 25 grams

Readj. - Min. 30 grams

Apply the tip of the No. 68C gram gauge to spring 5 at a point just in front of the contacts. The contact pressure of

the bifurcated spring shall be measured by engaging both contacts of the spring with the gauge at the same time.

2.04 Contact Make (Readjust Only):

(a) When no plug is inserted into the jack both contacts on spring 7 shall make contact with the associated contacts on spring 6. Gauge by eye.

(b) With the No. 240B plug or its equivalent inserted into the jack both contacts of spring 5 shall make contact with the associated contacts on spring 6. Gauge by eye.

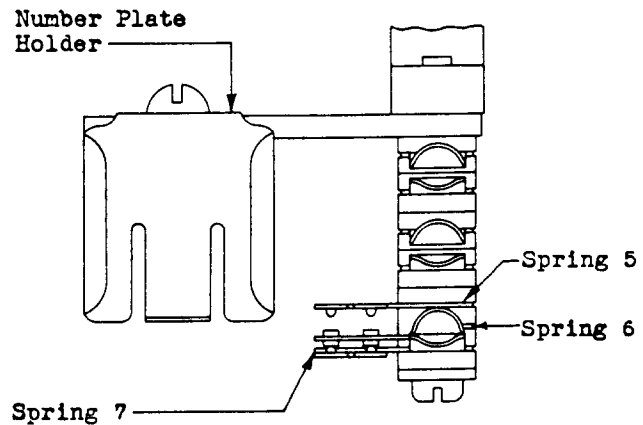

Fig. 2 - No. 463A Jack

2.05 Contact Separation: The contact separation between springs 5 and 6 with no plug inserted or between springs 6 and 7 with a No. 240B plug or its equivalent inserted into the jack, shall be

Test - Min. .008 in.

Readj. - Min. .010 in.

Gauge by eye.

3. ADJUSTING PROCEDURES

3.001 List of Tools and Gauges

Code or Spec. No.	Description
<u>Tools</u>	
KS-7782	Parallel jaw pliers
<u>Gauges</u>	
68C	70-0-70 Gram Gauge
240B	Plug (Or an equivalent plug with the same number of terminals)

SECTION 032-356-701

3.01 Cleaning (Rq.2.01)

(1) Clean the contacts when necessary in accordance with the section covering the cleaning of relay contacts and parts.

3.02 Contact Alignment (Rq.2.02)

3.03 Contact Pressure (Rq.2.03)

3.04 Contact Make (Rq.2.04)

3.05 Contact Separation (Rq.2.05)

(1) Adjust the springs as necessary with the KS-7782 parallel jaw pliers until the requirement is met.