

CODED CONNECTORS—915 THROUGH 939
DESCRIPTION

LIBRARY
FILE COPY

1. GENERAL

1.01 This section lists and illustrates coded connectors within the part or type number range of 915 through 939, used for the maintenance and operation of equipment in central offices.

1.02 Whenever this section is reissued, the reason for reissue will be listed in this paragraph.

2. DESCRIPTION OF CONNECTORS

2.01 915-Type: The 915-type connectors (A and M only) (Fig. 1) consist of a molded housing of insulating material containing 12 spring terminals, equipped with contacts having a gold overlay for connection to printed wiring terminals on one side of a 1/16-inch thick printed wiring board. The wiring ends of the terminals are arranged for mechanically wrapped connections. Each connector has three "teeth" which must align with slots in the associated printed wiring board. The "teeth" are indexed alphabetically from one end of the connector (see Table A). The 915-type connector is arranged for snap-on mounting on a .078-inch thick mounting plate. The 915A, (A and M only) B, and C connectors are used in the 111A power plant. The 915D through J connectors are used in the 756A PBX.

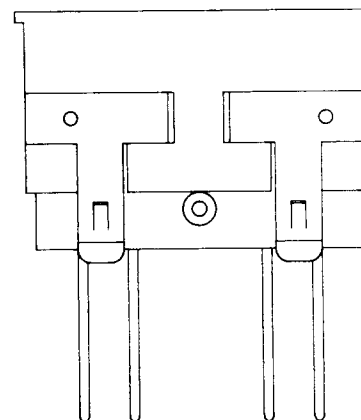
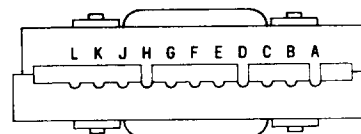

Fig. 1—915-Type Connector

TABLE A

TYPE CONNECTOR	POSITIONS OF TEETH
915A	A, D, H
915B	B, E, J
915C	C, F, K
915D	B, D, G
915E	B, D, H
915F	B, D, J
915G	B, D, K
915H	B, E, G
915J	B, D, F

NOTICE

Not for use or disclosure outside the
Bell System except under written agreement

2.02 916A: The 916A connector (Fig. 2) consists of a molded housing of insulating material having a molded polarizing rib and containing 50 spring terminals in two rows of 25 each. One end of each terminal is contained within the housing and is equipped with twin contacts for connection to a printed wiring terminal. The connector is arranged to make contact with printed wiring terminals on two sides of a 1/16-inch thick printed wiring board when inserted into the connector. The other end of each terminal protrudes through the wall of the housing and is arranged for two mechanically wrapped connections of 24-gauge wire. The 916A connector is used on the PBX American number identification project.

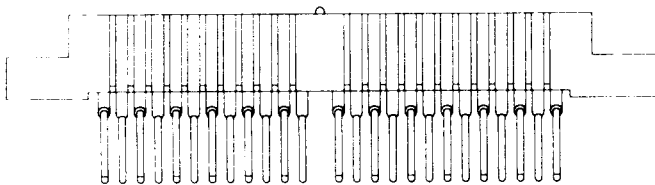
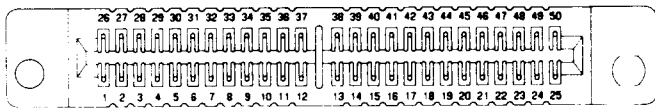

Fig. 2—916A Connector

2.03 919A: The 919A connector (A and M only) (Fig. 3) consists of a molded housing of insulating material containing two rows of 19 spring terminals. This connector is made to plug into the 925A and B connectors and to mount on metal frames or printed wiring boards. The 38 terminal ends of the connector are arranged for solder connection to fine wire. The 919A connector is used in the No. 101 Electronic Switching System (ESS).

2.04 921A and B: The 921A and B connectors (Fig. 3) consist of a molded housing of insulating material containing two rows of 14 spring terminals having ends arranged for solder connection to 0.062 inch thick printed wiring boards. The connectors are able to mate with the 924A and B connectors and to mount on metal frames. The 921A and B connectors are used in the No. 101 ESS.

2.05 922A and B: The 922A and B (A and M only) connectors (Fig. 3) consist of a molded housing of insulated material and is able to mate with the 925A and B connectors. These connectors are equipped with two rows of 19 spring terminals having ends arranged for solder connection to 0.062 inch thick printed wiring boards. The 922A and B connectors are used in the No. 101 ESS.

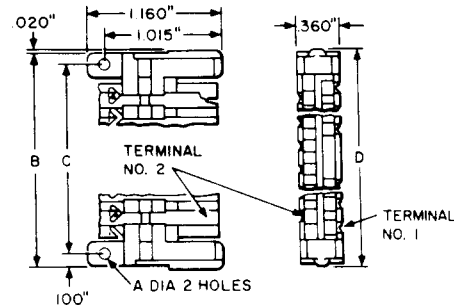

Fig. 3—919A, 921A or B, and 922A or B Connector

2.06 923A and B: The 923A and B connectors (Fig. 4) consist of a molded housing of insulating material and is made to plug into the 926A, B, C, and D connectors. These connectors are equipped with two rows of 23 spring terminals having ends arranged for solder connections to 0.062 inch thick printed wiring boards. The 923A and B connectors are used in the No. 101 ESS.

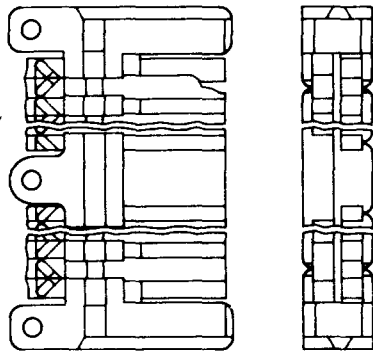

Fig. 4—923A or B Connector

2.07 924C and D: The 924C and D connectors (Fig. 5) consist of a molded housing of colored insulating material containing 28 terminals. The terminals on the terminal end are arranged for mechanically wrapped connections with 22- through 26-gauge wire. These connectors are made for insertion into the 918A or 921A connectors. The 924C and D connectors are used in the No. 101 ESS.

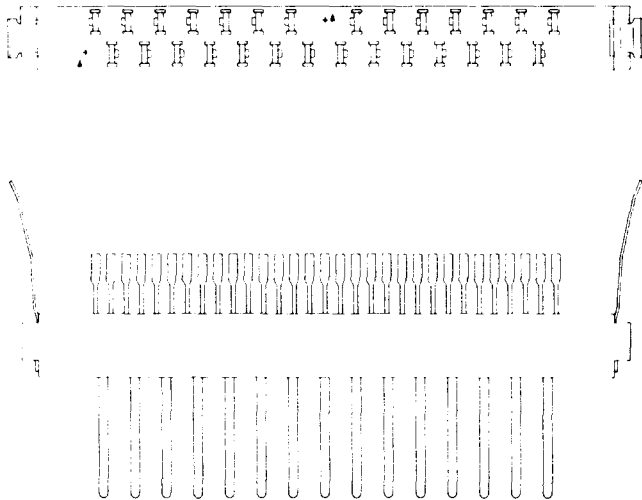

Fig. 5—924C or D Connector

- (a) **924C:** The 924C connector replaces the 924A connector.
- (b) **924D:** The 924D connector replaces the 924B connector.

2.08 925C and D: The 925C and D connectors (Fig. 6) consist of a molded housing of colored insulating material containing 38 terminals. The terminals on the terminal end are arranged for solderless wire wrap connection using 22- through 26-gauge wire. The connectors are able to mate with the 919A or 922A connectors and are used in the No. 101 ESS.

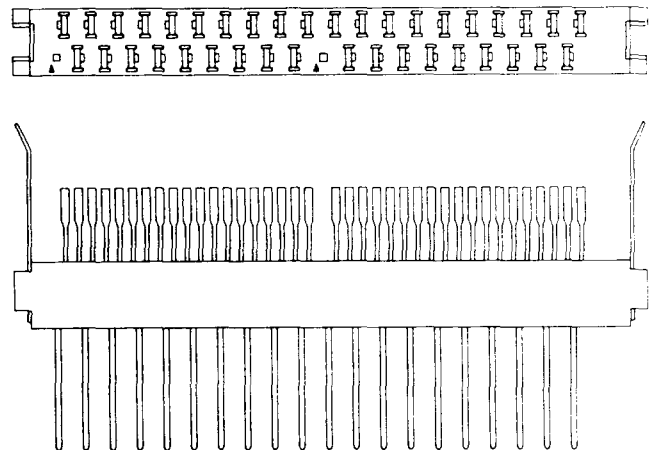

Fig. 6—925C or D Connectors

- (a) **925C:** The 925C connector replaces the 925A connector.
- (b) **925D:** The 925D connector replaces the 925B connector.

2.09 926E, F, G, and H: The 926-type connectors (A and M only) (Fig. 7) consist of a molded housing of colored insulating material. The terminals on the terminal end are arranged for solderless wire wrap connections using 22- through 26-gauge wire and is able to mate with the 920A or 923A connectors.

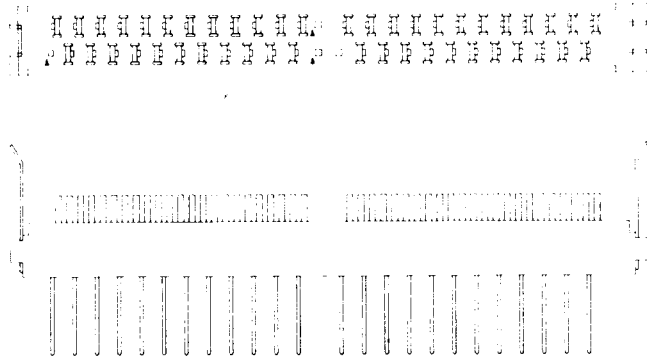

Fig. 7—926-Type Connectors

- (a) **926E:** The 926E connector has 46 terminals and replaces the 926A connector.
- (b) **926F:** The 926F connector has 46 terminals and replaces the 926B connector.
- (c) **926G:** The 926G connector has 47 terminals with a fork in position 26 to provide a stop to prevent the wrong circuit pack from being inserted. It replaces the 926C connector.
- (d) **926H:** The 926H connector has 47 terminals with a fork in position 26 to provide a stop to prevent the wrong circuit pack from being inserted. It replaces the 926D connector.

2.10 927A, B, C, D, E, E2, and F: The 927-type connectors consist of a molded housing of insulated material having 62 cavities in two rows of 31 each. One end of each terminal is contained within the housing and is equipped with twin contacts for connection to a printed wiring terminal. The connectors are arranged to make contact with a minimum 0.187 inch width of printed wiring terminals on two sides of a 0.062 inch thick printed wiring board when inserted into the connector. A coding insert, placed into a space cavity, will provide keying. For each coding insert used, the useful contacts are reduced by two.

- (a) **927A:** The 927A connector (Fig. 8) is equipped with 40 spring terminals in positions 1 through 40. The wiring ends of the terminals are arranged for two mechanically wrapped connections of 24-gauge wire. This connector is used in the 303 data sets.

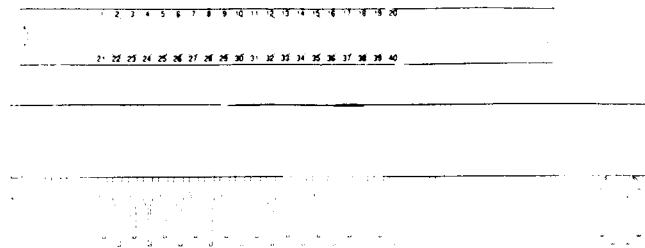

Fig. 8—927A or D Connector

- (b) **927B:** The 927B connector (Fig. 9) is equipped with 62 spring terminals in all positions that are arranged for two mechanically wrapped connections of 24-gauge wire. This connector is used in the 820A1 and B1 data sets and the 85A1 main station controller.

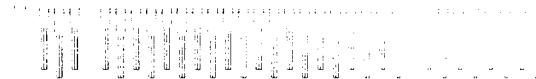

Fig. 9—927B, E, or E2 Connector

- (c) **927C:** The 927C connector (Fig. 10) is equipped with 62 spring terminals that are arranged for soldered connections. This connector is used in the 804M data auxiliary sets.

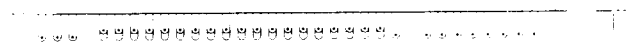

Fig. 10—927C Connector

- (d) **927D:** The 927D connector (Fig. 8) is equipped with 20 spring terminals in one row in positions 1 through 20 that are arranged for two mechanically wrapped connections of 24-gauge wire. This connector is used in the 403D data sets and 809B data auxiliary sets.

(e) **927E:** The 927E connector (Fig. 9) has the length of its 62 terminals increased to accommodate three wraps of 24-gauge or two wraps of 26-gauge wire (three of No. 26, if precautions are observed). This connector is used in the Engineering and Administration Data Acquisition System (EADAS).

(f) **927E2:** The 927E2 connector (Fig. 9) has the length of its 62 terminals increased to accommodate three wraps of 24-gauge or two wraps of 26-gauge wire (three of No. 26, if precautions are observed). The 927E2 connector is equipped with a molded housing of light green diallyl phthalate and is used on EADAS.

(g) **927F:** The 927F connector has terminals arranged for solder connections to a 0.062 inch thick printed wiring backplane or flexible tape. The terminals are arranged to accept two wraps of 26-gauge wire. The 927F connector is used in the E2A Telemetry System.

2.11 928A, C, D, and E: The 928-type connectors consist of a molded block of insulating material containing spring terminals and twin contacts. The mounting holes are offset with respect to the center of the card slot to allow complete interchangeability of mounting with the 911A connector on a standard shelf so that single-sided and double-sided printed circuit plug-ins can be intermixed.

(a) **928A:** The 928A connector (Fig. 11) has the wiring end of its 40 spring terminals arranged for mechanically wrapped connections.

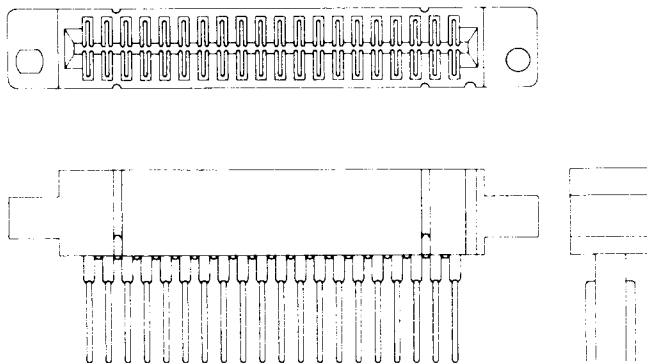

Fig. 11—928A, D, or E Connector

(b) **928C:** The 928C connector (Fig. 12) has the wiring end of its 40 spring terminals arranged for solder connections.

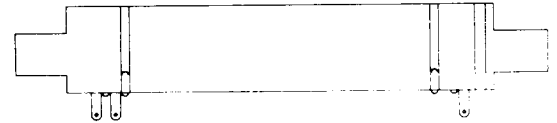

Fig. 12—928C Connector

(c) **928D:** The 928D connector (Fig. 11) is equipped with 12 contact spring assemblies located in positions 1, 2, 3, 5, 7, 9, 11, 13, 15, 17, 19, and 20 arranged for mechanically wrapped connections. All other positions are unequipped.

(d) **928E:** The 928E connector (Fig. 11) has a single row of 20 contact spring assemblies located in positions 1 through 20 arranged for mechanically wrapped connections.

2.12 929A: The 929A polarized connector consists of a molded block of insulating material, equipped with 38 pretensioned contact springs in a single row. The mating end of the connector provides the contacts with two-in-line-point contacts for a printed wiring board. The terminal end of the contact spring is arranged for two solderless wrapped connections of 26-gauge wire. The 929A connector is used in the No. 5 Crossbar System electronic route translator.

2.13 930A: The 930A connector (Fig. 13) consists of a molded block of insulating material containing 100 contact spring assemblies arranged on 0.150 inch centers in two rows of 50 each. The termination ends of the contact springs are arranged to accept two wraps of 26-gauge wire. The connector is arranged for slot mounting. The 930A connector is used in the 810A PBX.

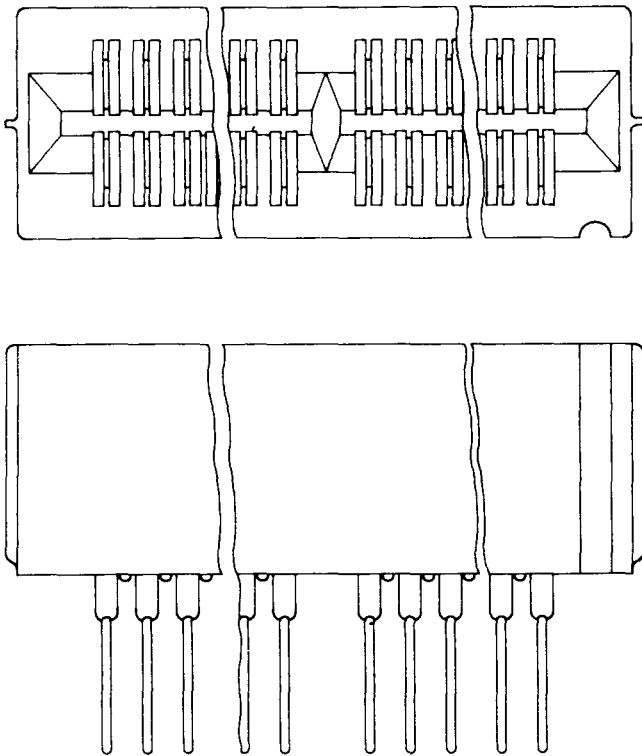

Fig. 13—930A Connector

2.14 931A, B, B2, C, E1, E2, and E3: The 931-type connectors consist of a molded block of insulating material containing 100 contact spring assemblies. The termination ends of the contact springs are arranged to accept two wraps of 26-gauge wire. These connectors are intended to accept a 0.062 inch thick, double-sided printed wiring board.

(a) **931A:** The 931A connector (Fig. 14) has its spring assemblies arranged on 0.150 inch centers in two rows of 50 each. This connector is used on the PBX PICTUREPHONE® Visual Telephone Service Systems.

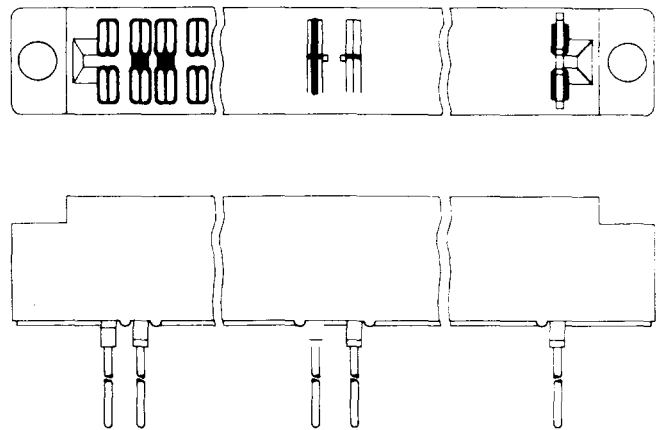

Fig. 14—931A, C, E1, E2, or E3 Connector

(b) **931B:** The 931B connector (Fig. 15) has 58 normally open contacts and 42 normally closed contacts. The normally closed contacts are used to maintain continuity for periods of short duration. The connector is used on the M12 multiplexer.

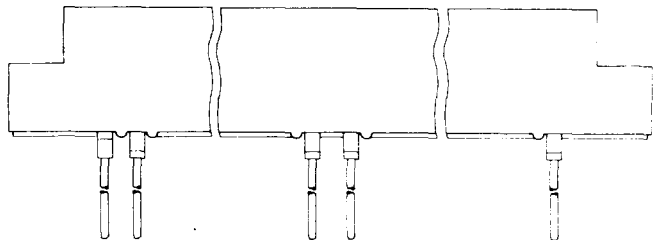

Fig. 15—931B or B2 Connector

(c) **931B2:** The 931B2 connector (Fig. 15) is provided with eight normally closed contacts in block positions 27 and 77, 28 and 78, 45 and 95, and 46 and 96. There are 92 normally open contacts in remaining block positions. The normally closed contacts are used to maintain continuity for periods of short duration. The 931B2 connector is used on the M34A multiplexer.

(d) **931C:** The 931C connector (Fig. 14) has positions 1 through 50 equipped with P-44L341 solder-type contact spring assemblies embossed after assembly. Positions 51 through 100 are equipped with 840736417 contact spring assemblies. The connector is used in the L5 Coaxial Carrier System.

(e) **931E1:** The 931E1 connector (Fig. 14) consists of a 931A connector with contact positions modified in order to install two KS-21584 coaxial adapters, two signal terminals, and eight ground terminals which constitute two impedance matching coaxial adapters that will mate with KS-20864 coaxial plugs. The connector is used on the M34A multiplexer and DR-18 radio line terminating bay.

(f) **931E2:** The 931E2 connector (Fig. 14) consists of a 931A connector with contact positions modified in order to install 16 KS-21584 coaxial adapters, 16 signal terminals, and 64 ground terminals which constitute 16 impedance matching coaxial adapters that will mate with KS-20864 coaxial plugs. The connector is used in the M34A multiplexer and DR-18 radio line terminating bay.

(g) **931E3:** The 931E3 connector (Fig. 14) consists of a 931A connector with contact positions modified in order to install 8 KS-21584 coaxial adapters, 8 signal terminals, and 32 ground terminals which constitute 8 impedance matching coaxial adapters that will mate with KS-20864 coaxial plugs. The connector is used on the M34A multiplexer and DR-18 radio line terminating bay.

2.15 934A, B, C, D, and E: The 934-type connectors consist of a molded block of insulating material containing 12 spring terminals, equipped with twin contacts for connection to a printed wiring board. The wiring end of each terminal is arranged for solder connections except as specified below.

(a) **934A:** The 934A connector (Fig. 16) is equipped with a single row of terminals which are arranged to make contact with printed wiring terminals on one side of a 0.031 inch thick printed wiring board.

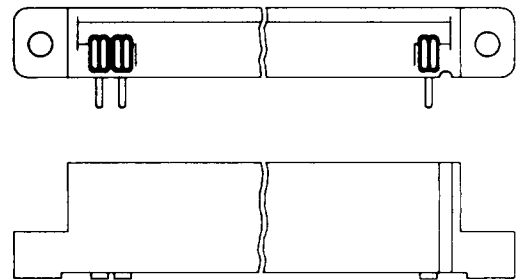

Fig. 16—934A Connector

(b) **934B:** The 934B connector (Fig. 17) is equipped with a 841681620 contact spring assembly.

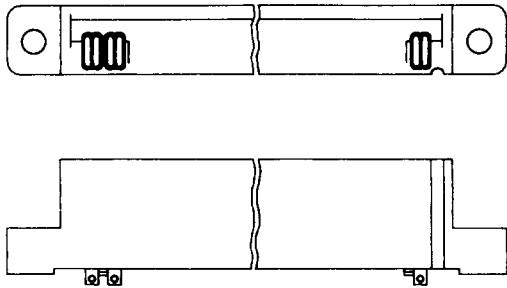

Fig. 17—934B Connector

(c) **934C:** The 934C connector is provided with bent terminals.

(d) **934D:** The 934D connector uses contact spring assemblies P-40V333 with terminals arranged for solderless wrapped connections. Terminals shall have a wrapping of 0.520 inch and they shall not extend more than 0.865 inch beyond the connector block.

(e) **934E:** The 934E connector has P-12B957 contact spring assemblies.

2.16 935A and B: The 935A and B connectors consist of a molded block of insulating material containing 15 spring terminals, equipped with twin contacts for connection to a printed wiring board. The connectors are arranged for rigid mounting by means of No. 8 screws with closest recommended mounting centers side-by-side of 0.562 inch, or for floating mounting by means of two P-47M058 screws with closest recommended mounting centers of 0.625 inch. The 935A and B connectors are used on the A6 channel bank.

(a) **935A:** The 935A connector (Fig. 18) has the wiring end of each terminal arranged for mechanically wrapped connections.

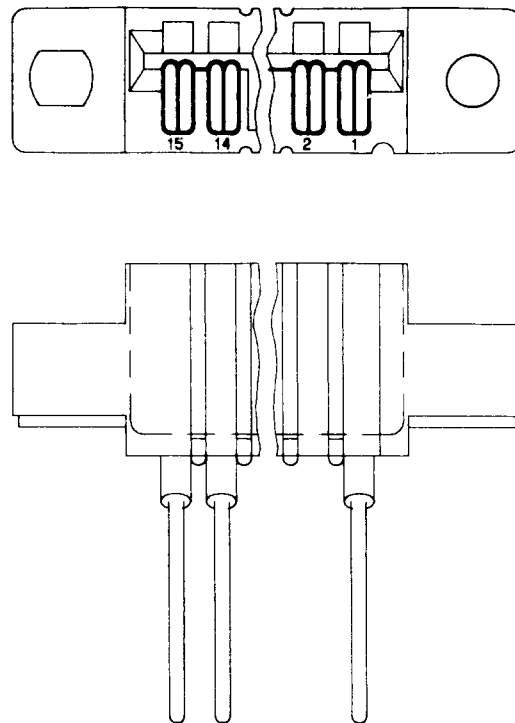

Fig. 18—935A Connector

(b) **935B:** The 935B connector (Fig. 19) is provided with terminals arranged for solder connection to a 0.062 inch thick printed wiring backplane or flexible tape. The terminals are arranged to accept two wraps of 26-gauge wire.

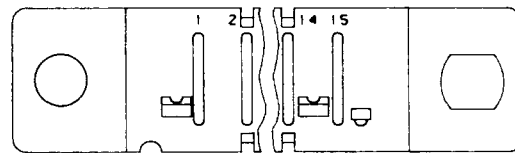

Fig. 19—935B Connector

2.17 938A, B, and C: The 938A, B, and C connectors (Fig. 20) consist of a molded plastic cavity block, a backplate, and contacts which are arranged to terminate on a printed wiring board. These connectors are used in 201- and 205-type repeaters and mates with the 421A plug.

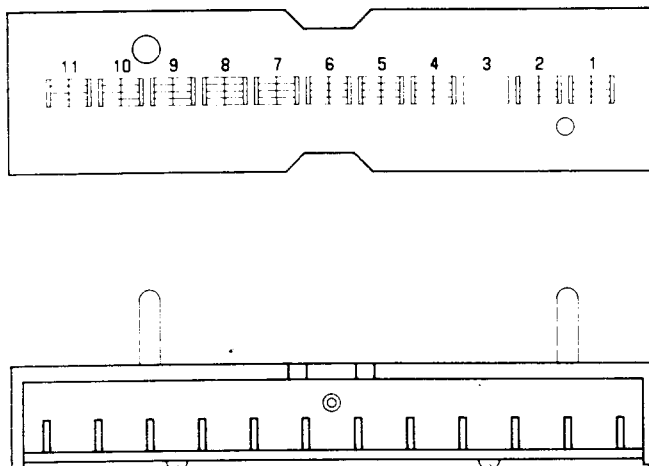

Fig. 20—938A, B, or C Connector

- (a) **938A:** The 938A connector has ten contacts.
- (b) **938B:** The 938B connector has nine contacts.
- (c) **938C:** The 938C connector has 11 contacts.

2.18 939A, B, C, and D: The 939-type connectors (Fig. 21) consist of a printed wiring board with one end having printed wiring terminals which serve as a connector. Also, they are provided with a cover block, rear block, handle, and guide, all of which are enclosed in a metal can. These connectors are used on the 475-type apparatus cases.



Fig. 21—939-Type Connector