

KEYS
272, 406, 498, 538, 556, 6013,
A4, B2, B9, AND B20 TYPES
REQUIREMENTS AND ADJUSTING PROCEDURES

1. GENERAL

- 1.01 This section covers 272-, 406-, 498-, 538-, 556-, 6013-, A4-, B2-, B9-, and B20-type keys.
- 1.02 This section is reissued to incorporate material from the addendum in its proper location.
- 1.03 Reference shall be made to Section 020-010-711 for additional information necessary for the proper application of the requirements listed herein.
- *1.04 Asterisk: Requirements are marked with an asterisk (*) when to check for them would necessitate the dismantling or dismounting of apparatus, or would affect the adjustment involved or other adjustments. No check need be made for these requirements unless the apparatus or part is made accessible for other reasons, or its performance indicates that such a check is advisable.
- 1.05 The operated position of a spring assembly is that position in which the normally open contacts are closed and the normally closed contacts are open.
- 1.06 The unoperated position of a spring assembly is that position in which the normally open contacts are open and the normally closed contacts are closed.
- 1.07 A straight lever is one which in its vertical position is capable of being operated to the front or rear or both.
- 1.08 An offset lever is one which has two operated positions toward the front, an intermediate position and a way-down position.
- 1.09 The normal (unoperated) position of a rotating-plunger-type key is that position in which the plunger springs rest against the wider surface of the plunger and the spring assemblies are unoperated.
- 1.10 The operated position of a rotating-plunger-type key is that position in which the plunger springs rest against the narrower surface of the plunger and the spring assemblies involved are operated. On keys equipped with 2-way throw plungers, only those contacts on the side to which the plunger is rotated are operated.

- 1.11 The normal (unoperated) position of a key equipped with a straight lever is that position in which the lever is perpendicular to the keytop and the spring assemblies are unoperated.
- 1.12 The operated position of a key equipped with a straight lever is that position in which the lever is thrown either to the extreme front or rear and the spring assemblies involved are operated.
- 1.13 The normal position of a key equipped with an offset lever is that position in which the lever is perpendicular to the keytop and the spring assemblies involved are operated.
- 1.14 The intermediate position of a key equipped with an offset lever is that position of the lever in which the spring assemblies involved are unoperated and the lever can be moved to either front or rear.
- 1.15 The way-down position of a key equipped with an offset lever is that position in which the lever is operated to the extreme front of the key and the spring assemblies involved are operated.
- 1.16 When checking values of 0.012 inch, 0.016 inch, and 0.025 inch by eye, the use of a blade of a standard thickness gauge of corresponding thickness is recommended as a reference to insure accuracy.

2. REQUIREMENTS

Rotating-plunger-type Keys

- *2.01 Cleaning
- (a) Contacts shall be cleaned in accordance with Section 022-186-811.
 - (b) Other parts shall be cleaned in accordance with approved procedures.
- 2.02 Plunger Movement: Fig. 2(A)
- (a) The plunger shall operate freely in the key frame.
Gauge by feel.
 - *(b) It shall not be possible to operate the contacts by any side thrust on

SECTION 032-709-701

the plunger or by rotating the plunger to remove backlash when the key is in either its operated or unoperated position.

Gauge by feel.

- * 2.03 Contact Alignment: Fig. 1(A) - The contacts shall line up so that the point of contact falls wholly within the boundary of the opposing contact at all times during contact.

Gauge by eye.

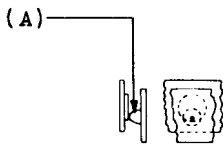

Fig. 1 - Contact Alignment

- * 2.04 Spring Clearance

(a) Fig. 2(B) - There shall be a clearance between springs designed never to make contact and between any spring and the frame whether in the operated or unoperated position of the key of:

Min 0.016 in.

Gauge by eye.

(b) Fig. 3(A) - The distance between springs designed to make contact shall be:

Min 0.008 in.

except at the contact points.

Gauge by eye.

- * 2.05 Contact Separation: Fig. 2(C)

(a) Unless otherwise specified, the separation between any pair of contacts normally open or between any pair of contacts that are opened when the key is operated, shall be:

Min 0.016 in.

Gauge by eye.

(1) The separation of the outside contacts can be gauged visually without removing the spring unit from the keyshell, but in order to view the separation for inner contacts of any key it is necessary to remove the spring assembly from the shell and also the plunger. Holding the spring assembly at the base, place the plunger between

the plunger springs in such a position that the center of the plunger will be approximately in line with the center of the base as shown in Fig. 3. This will approximate the actual condition when the key is assembled. Turn the plunger to its operated position and note whether or not the specified contact separation requirement is met.

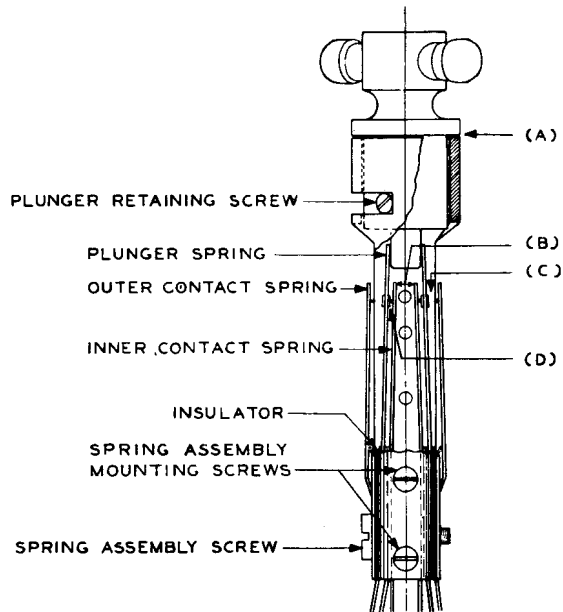

Fig. 2 - Spring Clearance, Contact Separation, and Contact Pressure

(b) Nos. 272F and 272G Keys: The separation between any pair of contacts normally open or between any pair of contacts that is opened when the key is operated, shall be:

Min 0.025 in.

Gauge by eye. See (a)(1)

(c) No. 406J and 538-type Keys - Make-break Spring Combination: The separation between the normally open contacts or the contacts that are opened when the key is operated, shall be:

Min 0.012 in.

Gauge by eye. See (a)(1).

- * 2.06 Contact Pressure: Fig. 2(D)

(a) Unless otherwise specified, there shall be a pressure between all closed contacts of:

Test - Min 50 grams
Readjust - Min 55 grams

Use the No. 68B gauge.

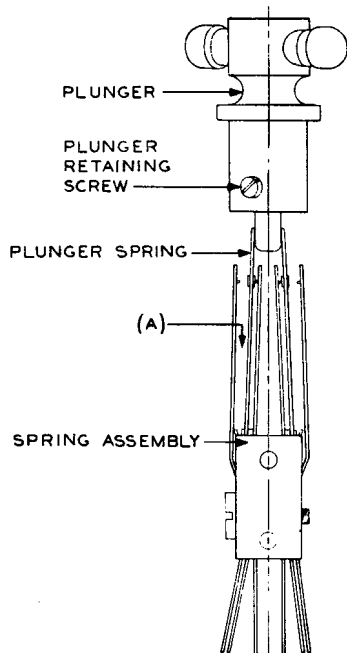

Fig. 3 - Method of Checking Contact Separation, Contact Follow, and Contact Sequence

(b) No. 406A Key: The pressure shall be:

Test - Min 155 grams
Readjust - Min 170 grams

Use the No. 62B gauge.

* 2.07 Flexible Contact Spring Position: The flexible contact springs (springs which are made of two parts riveted together) shall rest on their respective stop springs when the plunger is in the unoperated position for normally open contacts and in the operated position for normally closed contacts. It is not necessary for the spring to rest on the stop spring for its entire length, but it must rest on the end of the stop spring nearest the contact.

Gauge by eye.

* 2.08 Plunger Spring Position

(a) Fig. 6(A) - Both plunger springs shall rest against the plunger in the unoperated position.

Gauge by eye.

(b) Fig. 5(A) - No. 406A Key: There shall be a clearance between the plunger and the plunger springs in the unoperated position of the key.

Gauge by eye.

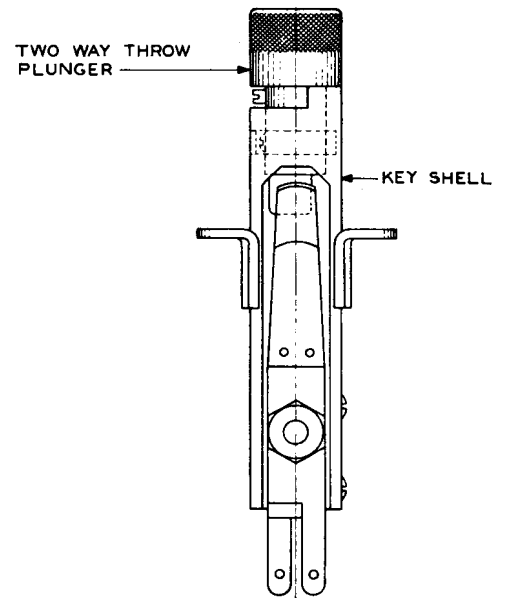

Fig. 4 - 498-type Key

* 2.09 Contact Follow

(a) Fig. 6(B) - Unless otherwise specified, there shall be a follow on all outside contacts of:

Min 0.010 in.

Gauge by eye.

This requirement need not apply to the normally closed contacts on the No. 406J key.

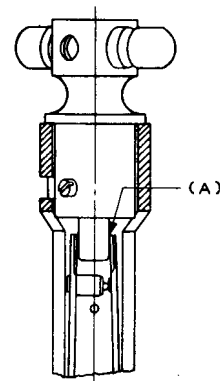

Fig. 5 - 406-type Key

(b) Fig. 6(C) - The follow on the inside contacts shall be sufficient to

SECTION 032-709-701

prevent operation by the side thrust of the plunger and shall be:

Min 0.005 in.

Gauge by eye.

This requirement does not apply to the No. 406J key.

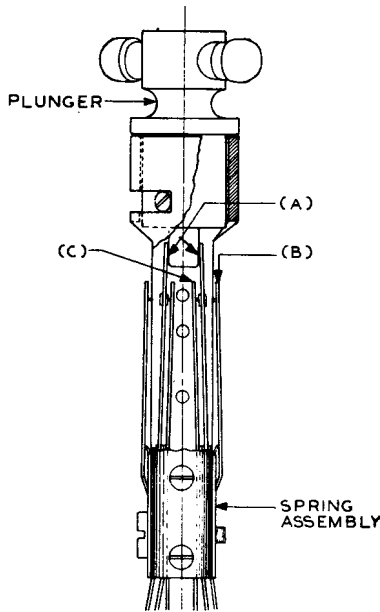

Fig. 6 - 272-type Key

* 2.10 Contact Sequence

(a) Fig. 7A(A) - Normal Contact Sequence - Break-make Combinations: Unless otherwise specified, the normally closed contacts in each set of break-before-make contacts shall break before its associated open contact makes by:

Min 0.006 in.

Gauge by eye.

In the case of the No. 272G key the interval shall be:

Min 0.015 in.

Gauge by eye.

(b) Fig. 7B(A) - Cross Sequence - Break-make Spring Combinations on Ringing and Coin Control Spring Combinations: Unless otherwise specified, all normally closed contacts operated by the rotation

of the plunger shall break before any of the normally open contacts make by:

Min 0.006 in.

Gauge by eye.

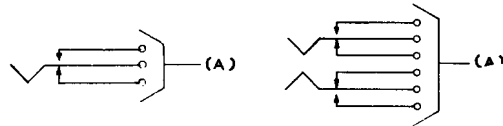

Fig. 7A

Fig. 7B

Fig. 7 - Contact Sequence

(c) Other Contact Sequences: When specified on the circuit drawing.

Lever-type Keys

* 2.11 Cleaning

(a) Contacts shall be cleaned when necessary in accordance with Section 022-186-811.

(b) Other parts shall be cleaned when necessary in accordance with approved procedures.

2.12 Lever Movement

(a) Fig. 8(A) - The cam shall turn freely in its bearings.

Gauge by eye and feel.

To check whether the lever binds, move the lever its full distance and release it, noting whether the operation is smooth throughout its movement. A slight drag is not considered objectionable if the lever returns consistently to the unoperated position.

*(b) Fig. 8(B) - The hard rubber rollers shall turn freely on their bearings.

Gauge by eye and feel.

To check whether the rollers bind, move the lever slowly about one-half its total movement in one direction and note whether the roller rotates on its bearing. If it does not, remove the tension of the plunger springs with the fingers and attempt to rotate the roller with the KS-6320 orange stick.

* 2.13 Relation of Plunger Springs to Rollers and Cam

(a) Fig. 8(C) - On keys equipped with a straight lever, the pressure of the plunger springs against the roller shall be such that the lever will be held normally in the vertical position and when the lever is released slowly it shall return to the vertical position by the pressure exerted by the springs.

Gauge by eye.

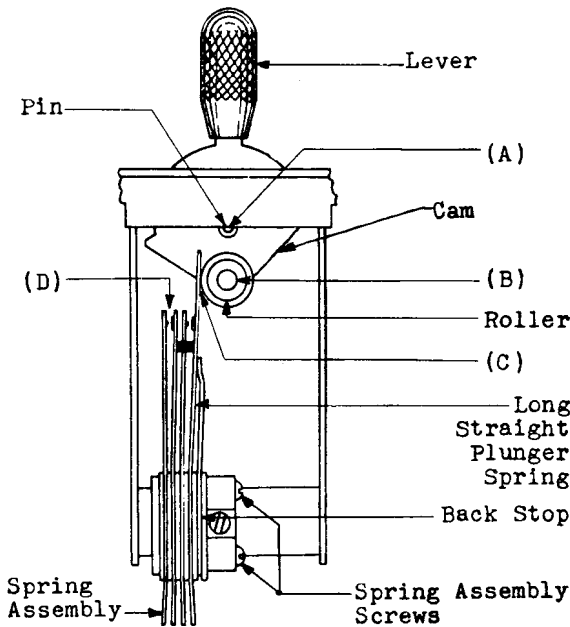

Fig. 8 - One-way Lever-type Key

(b) Fig. 9(A) - On keys equipped with an offset lever, the pressure of the plunger springs against the roller shall be such that when the lever is in the intermediate position the center of the roller shall line up approximately with the vertical centerline of the unit. When the lever is released slowly from the normal or way-down position, it shall return to the intermediate position by the pressure exerted by the springs.

Gauge by eye.

(c) Fig. 10(A) - (Applies at the time of turnover to the telephone company only.) On keys equipped with crook plunger springs, there shall be a clearance between the lip and the bend at the top of

the vertical portion of the phosphor-bronze spring of the unoperated spring combination when the roller on the cam has operated the spring combination on the opposite side of:

Min 0.004 in. Gauge by eye.
Max 0.022 in. Use the No. 74D gauge.

Caution: If the phosphor-bronze spring is not in accordance with this requirement, do not attempt to adjust it.

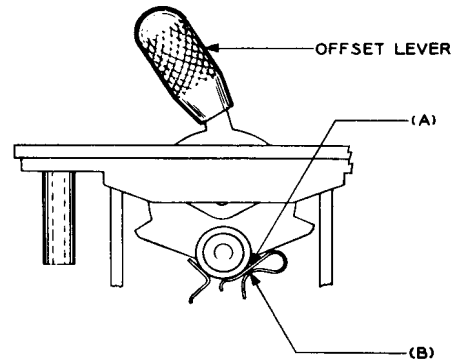

Fig. 9 - Relation of Plunger Springs to Roller and Cam

(d) Fig. 9(B) - With the lever in the vertical position where the key is equipped with a straight lever, or with the lever in the intermediate position where the key is equipped with an offset lever, the inclined part of the crook spring should preferably be pressed against the vertical part, but a slight airgap will be satisfactory.

Gauge by eye.

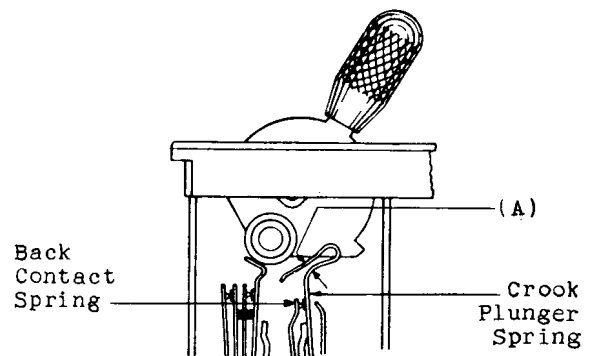

Fig. 10 - Relation of Plunger Springs to Roller and Cam

*2.14 Relation of Plunger Springs to Cam and Key Frame

(a) Fig. 11(A) - The plunger springs shall clear the cam by:

Min 1/32 in.

Gauge by eye.

(b) Fig. 11(B) - The vertical centerline of each spring shall be approximately perpendicular to the keytop.

Gauge by eye.

On keys equipped with 27/32-inch keytops, this requirement shall be considered being met if there is some clearance between the plunger springs of the key under consideration and its adjacent keys.

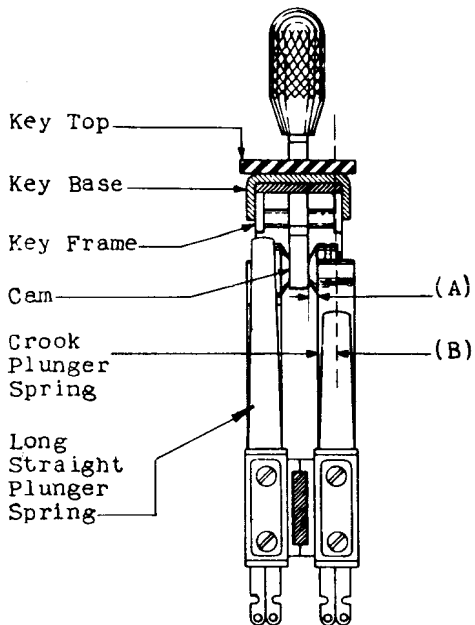

Fig. 11 - Relation of Plunger Springs to Cam and Key Frame

*2.15 Contact Alignment: Fig. 12(A) - The contacts shall line up so that the point of contact falls wholly within the boundary of the opposing contact at all times during contact.

Gauge by eye.

*2.16 Contact Separation: Fig. 8(D)

(a) Fig. 13(A) - Unless otherwise specified, the separation between any pair of contacts normally open or between any pair of contacts that are opened when the key is operated shall be:

Min 0.016 in.

Gauge by eye.

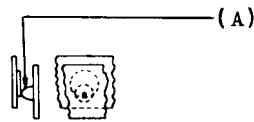

Fig. 12 - Contact Alignment

Note: On 2-way keys equipped with either straight or offset handles, when the lever is operated to one side the contact springs of the unoperated spring combination shall not change their adjustment beyond their requirements for the normal position.

Gauge by eye.

Exceptions to Requirement (a)

(b) Fig. 13(B) - On contacts which function by being acted upon by the making or breaking contact of another spring instead of either by a plunger spring or by a spring actuated directly by a plunger spring by means of a stud, there shall be a contact separation of:

Min 0.012 in.

Gauge by eye.

Note: See note following Rq 2.16(a).

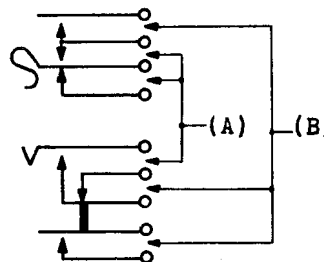

Fig. 13 - Contact Separation

(c) Fig. 14(A) - Where a key is equipped with a continuity (make-before-break) combination on each side of the plunger spring, the separation between the contacts which function by being acted upon by the making or breaking contact of another spring instead of by a plunger spring shall be:

Min 0.010 in.

Gauge by eye.

Note: See note following Rq 2.16(a).

(d) Fig. 15(A) - Where a key is equipped with an offset lever, the separation between those contacts which are broken by the action of a spring which is

operated directly by a plunger spring by means of a stud shall be:

Min 0.012 in.

Gauge by eye.

Note: See note following Rq 2.16(a).

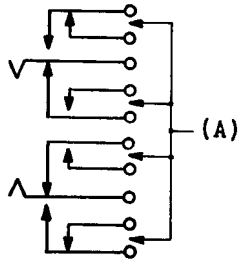

Fig. 14 - Contact Separation

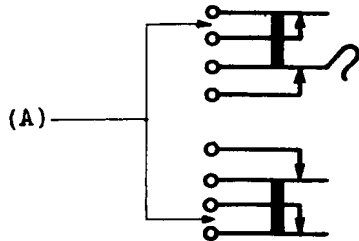

Fig. 15 - Contact Separation

* 2.17 Spring Clearance: Fig. 16(A)

(a) There shall be a clearance between springs designed never to make contact and between any spring and the frame whether in the operated or unoperated position of the key of:

Min 0.016 in.

Gauge by eye.

(b) The separators shall not rub on the springs through which they pass when the lever is operated.

Gauge by eye.

* 2.18 Contact Pressure: Fig. 16(B) - There shall be a pressure between all closed contacts of:

Test - Min 50 grams

Readjust - Min 55 grams

Use the No. 68B gauge.

Note: See note following Rq 2.16(a).

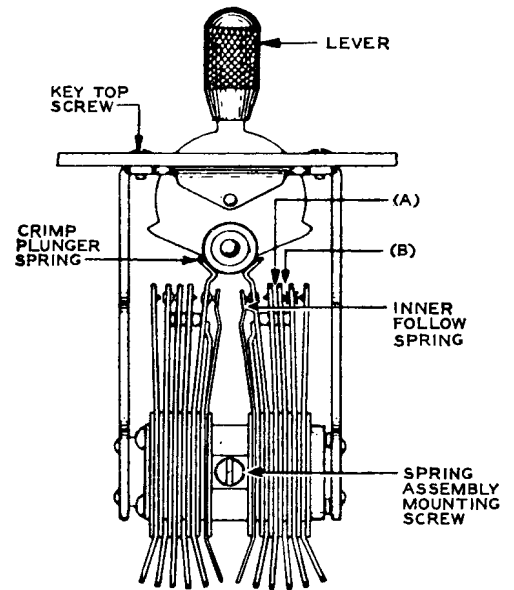

Fig. 16 - Spring Clearance

* 2.19 Other Spring Pressures

(a) Fig. 17(A) - On keys which are equipped with springs mounted on only one side of the roller and a one-way lever, the pressure of the plunger springs against the rollers shall be:

Max 225 grams.

Use the No. 62B gauge.

Fig. 17(A) - In the case of the crimp plunger springs, the pressure shall be measured at the point where the spring bends from the straight portion to the crimp.

Fig. 8(C) - In the case of long, straight plunger springs, the pressure shall be measured as close as practicable to the point where the spring rests against the roller.

(b) On keys equipped with straight levers, the plunger spring shall rest against its associated stop spring or have a clearance of:

Max 0.010 in.

when the lever is in the normal position.

Gauge by eye.

(c) On keys equipped with offset levers, the plunger spring shall rest against its associated stop spring or have a clearance of:

Max 0.010 in.

when the lever is in the intermediate position.

Gauge by eye.

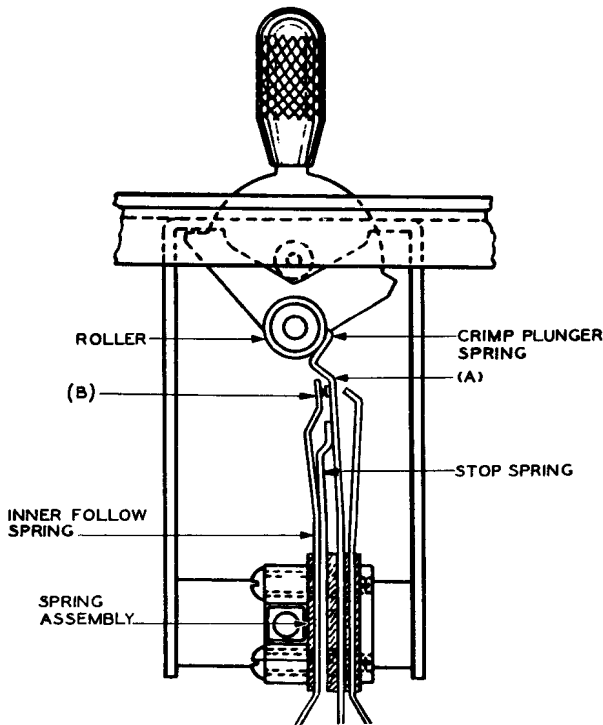

Fig. 17 - Key Equipped With Crimp Plunger Spring

* 2.20 Contact Follow: Fig. 17(B) - There shall be a contact follow on all contacts of:

Min 0.010 in.

Gauge by eye.

In make-before-break spring combinations, where the long, thin spring makes contact with the short, heavy spring that acts as a stop spring, this requirement does not apply.

Note: See note following Rq 2.16(a).

* 2.21 Contact Sequence

(a) Fig. 19A(A) - Normal Contact Sequence - Break-make Combinations: Unless otherwise specified, the normally closed contacts operated directly by a plunger spring of an individual spring assembly shall break before the normally open contacts of the same assembly directly associated with the plunger spring make by:

Min 0.006 in.

Gauge by eye.

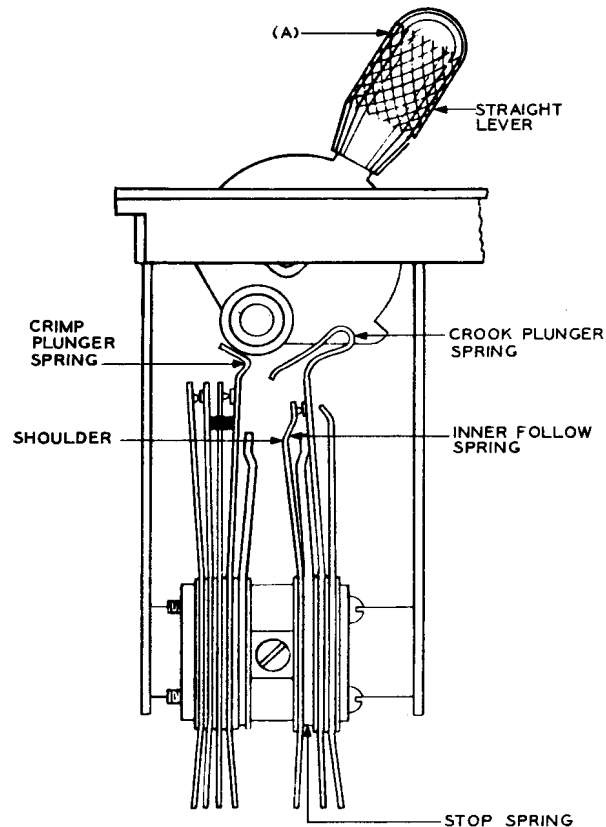

Fig. 18 - Key With Lever Operated to One Side

(b) Fig. 19B(A) - Cross Sequence - Break-make Spring Combinations on Ringing Spring Assemblies or When Specified on Circuit Drawing: Unless otherwise specified, all normally closed contacts operated by the throw of the lever shall break before any of the normally open contacts make by:

Min 0.006 in.

Gauge by eye.

(c) Other Contact Sequences: When specified on the circuit drawing.

2.22 Nonclick: Unless otherwise specified, this requirement shall apply where the lever unit is equipped with talking and ringing spring combinations on the same unit and shall apply to both combinations.

(a) Keys With Straight Levers: When the lever is restored unrestrained from the operated to the normal position, no normally closed contacts of the opposite side shall break and no normally open contacts of the opposite side shall make.

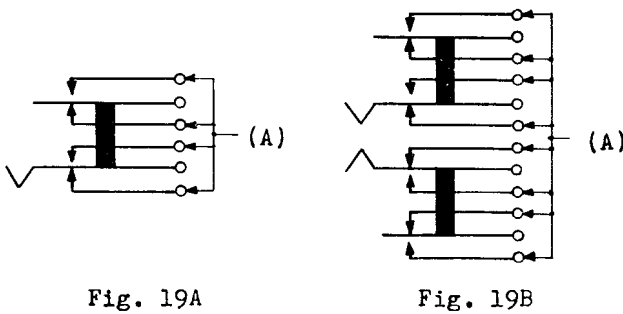

Fig. 19A

Fig. 19B

Fig. 19 - Contact Sequence

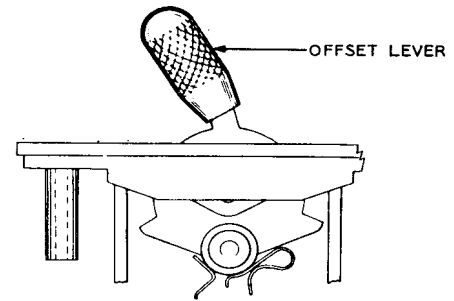

Fig. 20 - Key Equipped With Offset Lever

(b) Keys With Offset Levers: When the lever is restored unrestrained from the normal or way-down position to the intermediate position, no normally closed contacts of the opposite side shall break and no normally open contacts of the opposite side shall make.

2.23 Lever Release: Fig. 18(A)

(a) Keys Equipped With a Straight Lever:
Unless otherwise specified, the pressure required to restore the lever from the locked position shall be:

Test - Min 50 grams
Readjust - Min 55 grams

Use the No. 68B gauge.

(b) Keys Equipped With an Offset Lever:
The pressure required to restore the lever from the normal to the intermediate position shall be:

Test - Min 100 grams
Readjust - Min 110 grams

Use the No. 79C gauge.

(c) Keys Equipped With an Offset Lever:
The pressure required to restore the lever from the way-down position to the intermediate position shall be:

Test - Min 50 grams
Readjust - Min 55 grams

Use the No. 68B gauge.

(d) In checking these requirements, the pressure shall be applied at the top portion of the handle and as near perpendicular to it as possible. The lever shall return unaided from the locked position before the lever has travelled a maximum of 15 degrees.

3. ADJUSTING PROCEDURES

3.001 List of Tools, Gauges, and Materials

Code or Spec No.	Description
<u>Tools</u>	
429A	Key Support
429B	Key Support
483A	Adjuster
485A	Smooth-jaw Pliers
KS-2663	5-3/8-in. Jewelers File
KS-2993	Flat Brush
KS-6320	Orange Stick
KS-6854	3-1/2-in. Screwdriver
KS-7782	Parallel-jaw Pliers
-	3-in. Cabinet Screwdriver
-	Starrett Pocket Screwdriver No. 559A
<u>Gauges</u>	
62B	0-700 Gram Gauge
68B	70-0-70 Gram Gauge
74D	Thickness Gauge Nest
79C	0-200 Gram Push-pull Tension Gauge
<u>Materials</u>	
KS-14666 (or replaced D-98063) or KS-2423	Cloth
KS-7860	Petroleum Spirits

Code or
Spec No.DescriptionMaterials

- Toothpicks (hardwood, flat at one end and pointed at the other)
- No. 22 Bare Tinned Copper Wire

3.002 Due to the design and method of mounting these keys, it will not be practical to perform any of the adjustments specified herein for lever-type keys unless the key is removed from the keyshelf. At the time the key is removed, inspect the entire key for possible faults and make any adjustments that may appear necessary at this time. This will insure that the key is in proper working order before it is remounted.

3.003 To remove the key from the keyshelf proceed as follows. Raise the keyshelf and loosen the mounting screws with the 3-inch cabinet screwdriver. Raise the key out of the keyshelf as far as is permitted by the skinners. Place a No. 429A or 429B key support inside the lugs on each end of the key to support the key while making adjustments.

3.004 When adjusting the 6013-type key, remove the key from the box using the 3-inch cabinet screwdriver to remove the mounting screws and adjust the key in the same manner as the 272-type keys.

Rotating-plunger-type Keys*3.01 Cleaning (Rq 2.01)

- (1) Clean the contacts in accordance with Section 022-186-811. Clean other parts as outlined in procedure 3.02(4).

3.02 Plunger Movement (Rq 2.02)

- (1) Cracked, warped, or broken keytops of a universal-type key may cause the plunger to bind and thus prevent or delay the release of the plunger. In this case, replace the keytop.
- (2) Loose or missing screws in the keytop of a universal-type key may allow the keytop to move and thereby cause the plungers to bind. In this case, replace the missing screws and tighten all screws with the KS-6854 screwdriver.
- (3) If the plunger of a universal-type key binds in the slot, loosen the keytop screws with the KS-6854 screwdriver and shift the keytop until no bind occurs. If binding still occurs, ream out the slot in the keytop slightly.

(4) Examine the key to determine whether or not failure to operate is due to dirt or a gummy substance forming between the inside of the keyshell and the plunger or on the surface of the plunger spring which rests against the plunger. To determine whether or not this condition exists on 272-, 406-, 498-, 538-, and 556-type keys, remove the key from the keyshelf using the 3-inch cabinet screwdriver to loosen the screws holding the key to the keyshelf. If it is necessary to clean the plunger and plunger springs, remove the plunger from the keyshell. To do this remove the plunger retaining screw with the Starrett pocket screwdriver No. 559A and remove the plunger. In order to remove the plunger of a universal-type key, remove the keytop and then remove the screws holding the plunger unit to the key frame with the 3-inch cabinet screwdriver. Remove the plunger unit, the plunger retaining screw, and the plunger as described above. When the plunger has been removed, wipe it with a clean, dry KS-14666 cloth, removing all the gummy substance. Clean the inside of the keyshell and the surface of the plunger springs which rest against the plunger by means of a toothpick which has been dipped in petroleum spirits. Do not use the same toothpick for more than one operation. When the plunger springs are thoroughly dry, place the plunger back in the keyshell without the plunger retaining screw. This is done so that a preliminary test may be made. With the key plunger in this position, rotate the plunger a number of times to determine whether or not it operates freely.

(5) If the plunger operates freely but is sluggish in restoring to normal after the plunger, keyshell, and plunger spring have been cleaned in accordance with (4), it is probably due to the plunger springs not being properly adjusted. Failure of the plunger springs to rest against the plunger when in the normal position, or unequal pressure of the plunger springs, may cause this trouble. Since it is not possible to adjust the plunger springs while mounted in the keyshell, it will be necessary to remove the spring assembly. This is done by removing the spring assembly mounting screws with the KS-6854 screwdriver and then removing the spring assembly taking care not to lose the insulators. Do not loosen the spring assembly screw. When the spring assembly has been removed from the keyshell, examine the plunger springs to determine whether the opposite springs are bent at approximately the same angle. If the requirement is not met after the opposite plunger springs have been adjusted so that they are approximately equal, tension the plunger springs slightly by bending the two springs approximately equal amounts towards each other. At this time make any readjustments

that may be necessary to meet requirements 2.03 to 2.10, inclusive. Replace the spring assembly in the keyshell and fasten it securely. Recheck for proper plunger movement.

(6) If any contacts of the key are operated when a side thrust is applied to the plunger, it may be due to a worn or defective plunger. Whenever necessary to replace a plunger, remove it in accordance with the method outlined in (4).

(7) If the plunger is neither defective nor worn, the trouble is due to the key failing to meet the contact separation, contact follow, or contact pressure requirements. Adjust in accordance with procedures 3.03 to 3.10, inclusive.

- 3.03 Contact Alignment (Rq 2.03)
- 3.04 Spring Clearance (Rq 2.04)
- 3.05 Contact Separation (Rq 2.05)
- 3.06 Contact Pressure (Rq 2.06)
- 3.07 Flexible Contact Spring Position
(Rq 2.07)
- 3.08 Plunger Spring Position (Rq 2.08)
- 3.09 Contact Follow (Rq 2.09)
- 3.10 Contact Sequence (Rq 2.10)

(1) When making these adjustments, consult the associated circuit drawing and circuit requirement table and give proper consideration to the maintenance of any requirement for contact sequence which may be specified thereon. Do not straighten kinked springs unless the kink interferes with the proper adjustment of the key. Removing the kinks tends to weaken the spring and shorten the life of the key. Adjust the springs so that there will be the specified clearance between any spring and the frame and between springs designed never to make contact. Straightening the springs will usually rectify any trouble that may exist because of springs touching each other which are designed to clear at all times.

(2) Unless otherwise specified, adjust the springs close to the point where the spring leaves the spring assembly clamping block or insulators with the No. 485A pliers applied as shown in Fig. 21. In adjusting the springs, exercise care to adjust them in line with their movement so as not to twist them off center.

(3) Contact Alignment: Check the key to determine whether or not the springs are out of alignment. If necessary to readjust the springs, remove the spring assembly mounting screws using the KS-6854 screwdriver and then remove the spring assembly. Loosen the spring assembly screw very slightly with the 3-inch cabinet screwdriver and shift the springs so that they are all in alignment. Tighten the spring assembly screw and replace the spring assembly in the keyshell. Take

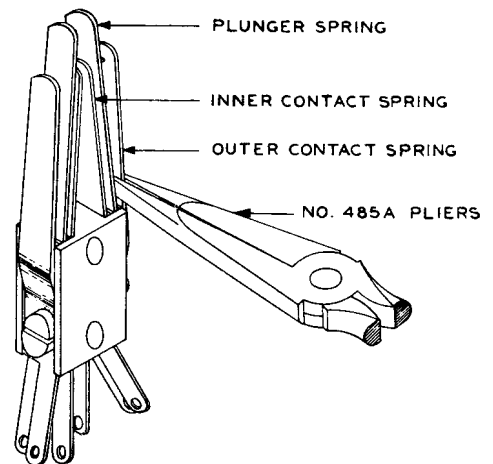

Fig. 21 - Method of Adjusting Contact Springs

care not to lose the insulators. When mounted, the sides of the spring shall be approximately equidistant from the sides of the opening in the keyshell and the contacts should rest wholly within the corresponding contact discs and as near the center as possible.

(4) Spring Clearance: Trouble due to springs touching each other which are designed never to make contact is caused either by springs being kinked or bowed or by excessive follow. Straighten the springs or reduce the excessive follow as required with the No. 485A pliers.

(5) Contact Separation: If the separation between either the inside or outside contacts is insufficient, remove the plunger from the plunger springs and adjust the contact springs very slightly away from or toward the center of the key as required, using the No. 485A pliers applied as shown in Fig. 21. Repeat the above adjustment until the proper contact separation has been obtained. Do not reassemble the key until preliminary tests have been made with the plunger between the springs in order to approximate actual conditions.

(6) Contact Pressure: Foreign matter wedged between contact springs may prevent springs making contact when the plunger is in the operated position. Remove the foreign matter with a toothpick which has been dipped in petroleum spirits. If the contact pressure requirement is still not met, readjust the springs as required as outlined in (2).

(7) Flexible Contact Spring Position: If the flexible contact spring does not rest against its stop spring as specified,

insert a piece of No. 22 bare tinned copper wire between the two springs close to the point where they are riveted together. Then place the No. 485A pliers over both the stop spring and the flexible contact spring close to the wire, as shown in Fig. 22, and pinch the two springs together with the pliers. It will be satisfactory to have a slight kink in the feather spring near the rivets which may be introduced in making this adjustment.

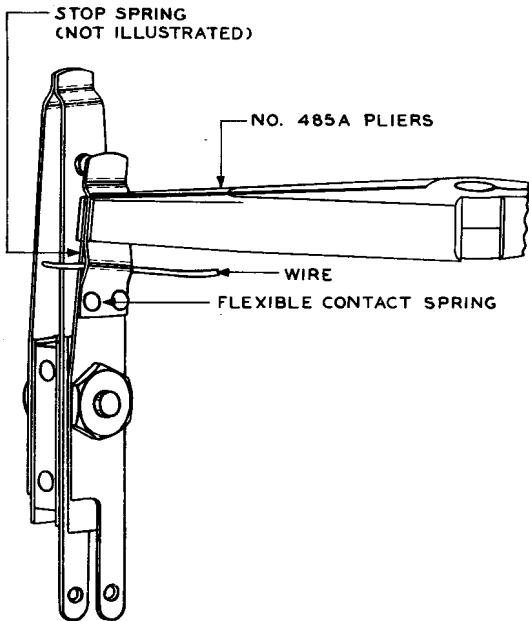

Fig. 22 - Method of Adjusting for Flexible Contact Spring Position

(8) Plunger Spring Position: With the plunger in position in the keyshell, turn it slightly, noting that its springs move with the slightest twisting motion.

Note: This requirement shall not apply to the No. 406A key. In checking the requirement for this key, it should be noted that there is a clearance between the plunger springs and the sides of the plunger when the key is in the unoperated position.

If it is possible to twist the plunger without moving the springs, it is an indication that the plunger springs do not rest against the plunger. Remove the spring assembly by loosening the spring assembly mounting screws with the KS-6854 screwdriver. Examine the springs to determine whether or not they are bent approximately the same. Bend each of the plunger springs with the No. 485A pliers until they have approximately the same profile. Then,

while holding the spring assembly, place the plunger between the two plunger springs noting that the springs lie against the plunger for their full width. When holding the plunger and spring assembly in this position, note that the center of the plunger is approximately in line with the center of the key base. This will approximate the actual condition when the key is fully assembled.

(9) Contact Follow: When readjusting for contact follow, adjust the stationary contact spring as described in (2), exercising care that the minimum contact separation is maintained. If a satisfactory contact follow cannot be obtained by this method, it will be permissible to adjust the spring close to the contact disc with the No. 485A pliers as indicated in Fig. 23. This bend should not be sufficiently great to make a visible kink in the spring.

(10) Contact Sequence: To adjust for contact sequence, increase or decrease the contact separation, contact pressure, contact follow, and spring clearances as required, following the methods outlined above.

(11) After all of the above requirements have been met, reassemble the key.

Lever-type Keys

* 3.11 Cleaning (Rq 2.11)

(1) Clean the contacts as outlined in Section 022-186-811. Clean other parts as outlined in 3.12(2) and (6), and 3.16 to 3.22(4).

3.12 Lever Movement (Rq 2.12)

(1) If a lever fails to move satisfactorily it may be due to any of the following:

(a) A foreign deposit on the surfaces of plunger springs over which the plunger rollers ride will prevent the lever from operating and restoring smoothly. If necessary, clean the springs with a clean toothpick which has been dipped in petroleum spirits. Do not use the same toothpick for more than one cleaning operation. When cleaning a plunger spring, operate the lever so as to operate the opposite spring combination. Do not permit petroleum spirits to get on the hard rubber rollers as it will tend to remove the wax lubricant from the rollers. Care shall be taken to see that no petroleum spirits are left on the plunger springs when the rollers come in contact with them.

(b) Cracked, warped, or broken keytops may cause the levers to bind and thus prevent or delay the release of the lever. In this case, replace the keytop.

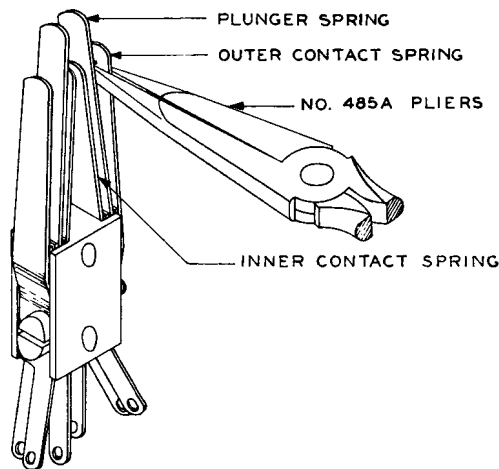

Fig. 23 - Method of Adjusting for Contact Follow

To do this, unscrew the lever handles, remove the keytop mounting screws with the KS-6854 screwdriver and remove keytop. Substitute a new keytop in place on the key and insert and securely tighten the mounting screws. Screw the lever handles in place.

- (c) Loose or missing screws in the keytop may cause it to move and bind the lever. Replace missing screws and tighten all screws with the KS-6854 screwdriver.
- (d) Rubbing of the cam against the keytop may be the cause of sluggish action. This is indicated by smooth, bright spots on the cam. In some cases, it may be possible to correct by loosening the keytop screws and shifting the keytop as required. However, when this is not possible due either to proximity to other keys or to no sideplay in the keytop, enlarge the slot in the keytop, for keys which have a removable keytop, with the KS-2663 file. To do this, remove the lever handles and remove the keytop mounting screws with the KS-6854 screwdriver and remove the keytop. Take care, however, in filing the slots not to enlarge them any more than necessary to clear the trouble.
- (e) If the bind is not removed by the above procedure, it may be corrected by removing the lever handles and keytop. Examine the cam and the slots in the key frame and key base for dirt. Clean the parts if necessary by means of the KS-2993 brush.
- (f) Sluggish action may result from faulty adjustment of crook and

locking plunger springs. In this case adjust the springs as outlined in 3.23.

(g) If the cam is worn attempt to compensate for the wear by adjusting the springs as outlined in 3.16 to 3.22, inclusive. If the wear cannot be compensated for or if the cam binds on its bearing, replace the frame and lever assembly as follows: Remove the lever handles and keytop as outlined in (3). Remove the key unit mounting screws with the 3-inch cabinet screwdriver and remove the key unit from the mounting plate. Remove the spring assembly mounting screw with the 3-inch cabinet screwdriver and remove the mounting nut where provided. Remove the spring assemblies from the frame and mount them on the replacing frame. Insert the mounting screw and nut and tighten the nut securely. Remount the unit securely in place on the mounting plate and remount and securely fasten the keytop and lever handles. Check to see whether the key meets its requirements, and if not, adjust as required.

3.13 Relation of Plunger Springs to Rollers and Cam (Rq 2.13)

3.14 Relation of Plunger Springs to Cam and Key Frame (Rq 2.14)

- (1) In the case of keys equipped with a straight lever, failure of a lever to be in the vertical position when the key is normal is often due to the plunger springs not being set in correct relationship with respect to the rollers and the cam. Likewise, in the case of keys equipped with offset levers, failure of the lever to assume its correct position when in the intermediate position is often due to incorrect relationship between the plunger springs, rollers, and the cam.
- (2) In some cases this incorrect relationship may be corrected by loosening the spring assembly mounting screws with the 3-inch cabinet screwdriver and shifting the spring assembly. Then tighten the mounting screws securely.
- (3) If the lever still fails to assume its correct position, the trouble may be caused by improper positioning of one or more of the plunger springs or to excessive or insufficient tension of the plunger spring against the roller. To correct this condition, operate the lever so that the rollers are away from the plunger spring under consideration and grasp the free end of the stop spring with the No. 485A pliers. Adjust the stop spring toward the plunger spring to decrease the tension of the plunger spring against the roller or away from it to increase the tension. It may also be necessary to increase or decrease the tension of the plunger spring or the

opposite plunger springs. The tension of these springs should be sufficient to cause the lever to return to its correct position when the lever is released slowly from its operated position. Make all adjustments on the plunger springs (except those involving the crook of the plunger spring) with the KS-7782 pliers applied approximately one-quarter inch from the point where the springs leave the clamping plate and insulators.

3.15 Contact Alignment (Rq 2.15)

(1) If the contacts do not line up satisfactorily, loosen the spring assembly screws slightly with the 3-inch cabinet screwdriver and shift the springs until each contact point lies wholly within the opposing contact, preferably as near the center as possible. Then tighten the screws securely. When mounted the springs should be in correct relationship with the cam and key frame. After aligning the contacts, check that the requirements as covered by 2.16 to 2.22, inclusive are met.

- 3.16 Contact Separation (Rq 2.16)
- 3.17 Spring Clearance (Rq 2.17)
- 3.18 Contact Pressure (Rq 2.18)
- 3.19 Other Spring Pressures (Rq 2.19)
- 3.20 Contact Follow (Rq 2.20)
- 3.21 Contact Sequence (Rq 2.21)
- 3.22 Nonclick (Rq 2.22)

(1) When making these adjustments, consult the associated circuit drawing and circuit requirements table and give proper consideration to the maintenance of any requirement for contact sequence which may be specified thereon.

(2) Before adjusting the springs, tighten all the spring assembly screws. If these screws were tight it will still be necessary to adjust the springs.

(3) Spring Clearance: If a separator rubs on the spring through which it passes, loosen the spring assembly screws slightly with the 3-inch cabinet screwdriver and shift the springs as required. Tighten the mounting screws securely. Take care in making this adjustment that the contact alignment requirement is still met. If the spring is excessively bowed or bent or if there is not the proper clearance between springs, straighten the spring before adjusting to meet the contact pressure requirement. To straighten the spring, apply the KS-7782 pliers to the spring just back of the bow or bend, and while exerting pressure to the right or left as required, draw the pliers upward the length of the bow. Repeat this operation as required until the spring is approximately straight. Take care when adjusting the springs to adjust them in line with their movement and to avoid tilting the spring.

(4) Contact Pressure, Other Spring Pressures, Contact Separation, and Contact Follow: Foreign matter wedged between the springs may prevent the springs from making contact when the lever is operated. Remove the foreign matter with a clean toothpick which has been dipped in petroleum spirits. If the requirement is still not met, proceed as follows. Place the KS-7782 pliers on the spring just below the contact and slide it down to where the spring leaves the clamping plates and insulators and adjust the spring to the right or left as required, exercising care not to disturb adjacent springs.

(5) If the desired pressure cannot be obtained by adjusting, as outlined in (4), without bowing the spring beyond its permissible limit or reducing the clearance between the springs below the specified minimum, place the pliers on the spring just back of the contact and slide them back to where the spring leaves the clamping plates and insulators as shown in Fig. 24. Draw the pliers upward the length of the spring, applying pressure as required so that the spring is formed into a slight gradual bow with the concave surface facing the associated spring. The magnitude of the bow to be formed in the spring must be learned by experience and should be such that when the final tension adjustment is made at the base, the spring will be approximately straight. Move the pliers to the base of the spring and adjust as covered in (4).

(6) Do not straighten kinked springs unless the kink interferes with proper adjustment of the spring assembly. Removing kinks tends to weaken the spring and to shorten its life. Normally straight springs that have been adjusted should have no sharp bends due to adjustment. A gradual bow, however, is permissible.

(7) If after the above adjustments have been made it is necessary to change the contact separation or contact follow, place the KS-7782 pliers just below the contact and adjust the spring toward or away from the associated spring as required. In the case of back contact springs associated with stop springs, bend the spring slightly at the shoulder with the No. 485A pliers. However, exercise care that when increasing the follow the contact pressure between the spring and plunger spring is not more than the maximum specified. In no case should the bend be enough to make a visible kink in the spring. In making this adjustment it may be necessary to readjust the tension as outlined in (5).

(8) On 2-way keys, the follow should be such that when the lever is moved over to one side, the contact springs of the unoperated spring combination will not

change their adjustments beyond the requirements for the normal position. Failure to meet this condition generally results from excessive pressure of the plunger springs against the plunger rollers or incorrect adjustment of the stop springs. This should be corrected by adjusting the position of the stop springs or by reducing the tension of the plunger spring slightly but not enough to interfere with any of the previous adjustments. Use the KS-7782 pliers.

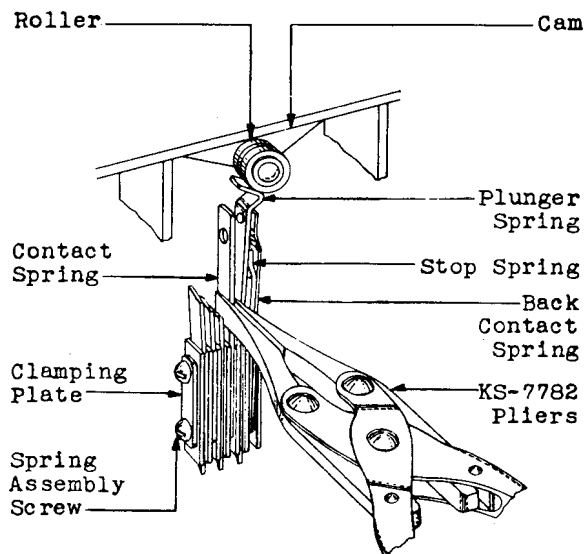

Fig. 24 - Method of Adjusting for Contact Separation, Spring Clearance, Contact Pressure, Other Spring Pressures, Contact Follow, Contact Sequence, and Nonclick

(9) Contact Sequence: When adjusting for contact sequence increase or decrease the contact separation, contact pressure, or contact follow as outlined in (1) to (8), inclusive.

(10) Nonclick: In readjusting for nonclick, operate the lever to the locked position and then push the handle until it reaches a point in its travel where it will release without further aid. On nonlocking units, allow the lever handle to return from the operated to the normal position unaided or unrestrained in any way. Should the key fail to meet the nonclick requirements, increase the follow on the normally closed contacts as outlined in (8). If the click is caused by the overthrow being so great as to momentarily make an open contact, increase the contact separation slightly and also reduce the tension of the contact springs which

exert too great a pressure against the plunger spring on the side from which the roller was released. In either case, recheck all previous adjustments.

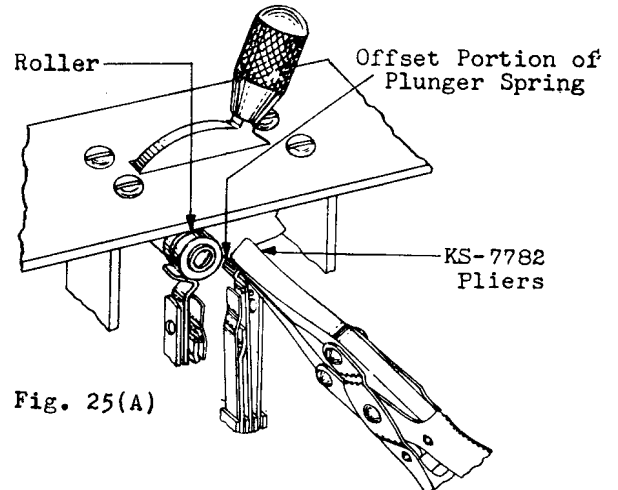

Fig. 25(A)

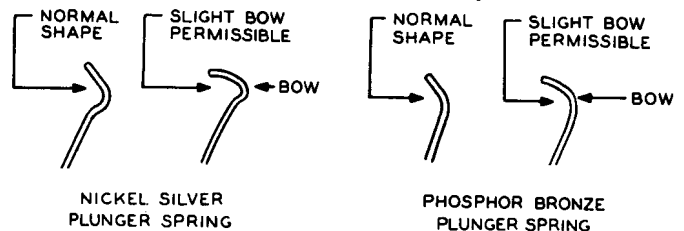

Fig. 25(B)

Fig. 25 - Method of Adjusting Plunger Spring for Lever Release

3.23 Lever Release (Rq 2.23)

(1) If the key fails to meet the requirements, adjust the angle of the offset portion of the plunger spring very slightly with the KS-7782 pliers, as shown in Fig. 25(A) so as to cause a greater drag on the lever rollers when returning to normal. The bend in the offset should not be such as to permit the spring to slip back under the roller and to return partially to the unoperated position, nor should it prevent the lever from returning unaided from the locked position after it has travelled a maximum of 15 degrees from the extreme locked position when the pressure is applied at the top of the cylindrical portion of the handle and perpendicularly to it. Do not use any lubricant on the key roller to facilitate this adjustment.

(2) In order to obtain a satisfactory locking condition it may sometimes be necessary to adjust the offset portion of the plunger spring so as to form a bow as shown in Fig. 25(B).

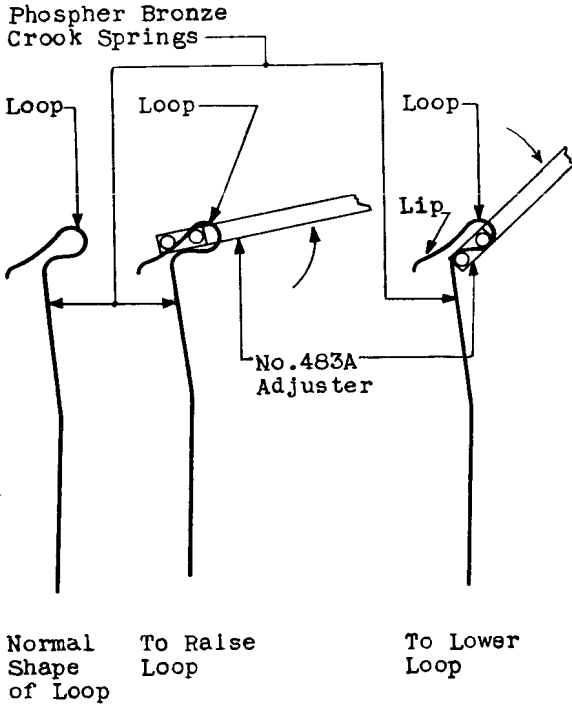

Fig. 26 - Method of Adjusting Phosphor-Bronze Crook Spring

(3) If the key still fails to meet its requirements, attempt to obtain a

satisfactory operation of the key by adjusting the vertical portion of the crook plunger spring before attempting to adjust the loop. Should it be found necessary to adjust the loop either through the replacement of plunger springs or because of excessive sluggishness in the return of the lever from the operated to the normal position or excessive loss of spring travel, the angle of the loop may be adjusted by means of the No. 483A adjuster as shown in Fig. 26. Make all adjustments at the curve between the vertical and horizontal part of the spring. Do not bend or change the shape of the upper or loop part of the spring. However, the lip of the spring may be adjusted upward, but the adjustment shall be in the form of a continuous curve not less than the radius of the roller. Raising the loop increases the travel of the spring when it is operated and increases its tendency to return the lever to its normal position. Lowering the loop tends to reduce the spring travel but increases the tendency for the lever to lock in the operated position. For this reason, the loop can be higher in nonlocking than in locking spring combinations. A slight change in the position of the loop will have a considerable effect on the adjustments. Particular care must be taken to avoid excessive bending and to guard against sharp bends or tool marks as these will result in early spring breakage.