

RELAYS
AL AND AM TYPES
(MAGNETIC LATCHING TYPES)
REQUIREMENTS AND ADJUSTING PROCEDURES

1. GENERAL

1.01 Reference shall be made to Section 020-010-711 covering general requirements and definitions for additional information necessary for the proper application of the requirements listed herein.

1.02 This section is reissued to:

- Incorporate the information contained in the Addendum, Issue 2.
- Revise 2.07.
- Revise Tables A and B.
- Revise the List of Tools, Gauges, Materials, and Test Apparatus.
- Revise Fig. 12 through 16.

1.03 Do not remove contact covers unless necessary in connection with relay testing or maintenance. If it is necessary to remove a cover, remount it as soon as practicable. When mounting a cover, make sure that the letters UP on the plastic surface are at the top. Also, take care that the cover is mounted without interfering with the card or contact springs by actuating the armature mechanically and noting that the contacts operate normally. If the contacts do not operate, restore the card into the armature notches. Do not attempt to interchange covers of AL-type relays with those of AM-type relays.

1.04 AL- and AM-type relays consist of parts similar to AF- and AK-type relays, respectively. The latter relays, however, will release when current is removed from the winding. The AL- and AM-type relays will remain operated after the operate current ceases to flow in the windings because the special cores used in these relays will remain magnetized. To release the AL- and AM-type relays, this remaining magnetism must be canceled out by a partial magnetization in a reverse direction. This

is done either (1) by applying current of an opposite polarity to the operate winding or (2) by applying a current of the original polarity to a release winding wound in a reverse direction.

1.05 Contact positions on AL- and AM-type relays are numbered 1 to 12 starting from the bottom except that on AM-type relays the positions 6 and 7 are omitted. Contact positions on the lower half of AM-type relays are numbered 1 to 5 and those on the upper half 8 to 12.

1.06 The two coils of the AM-type relay are mounted on the legs of the common core with the core plate secured to the front of the core legs. A magnetic shield is mounted between the two coils. Associated with each coil is an independent armature and card.

1.07 In the requirements for AM-type relays in this section, the term relay, except for references to the mounting of the entire relay, means the half of the relay being checked and, unless otherwise specified, all requirements apply to both halves of the relay.

1.08 Tables A and B show the various spring combinations for AL- and AM-type relays, respectively, and the contact positions used in each spring combination.

1.09 A *pair of contacts* as referred to in this section consists of the contact on a fixed single spring and the contact on one of the associated movable twin springs.

1.10 The terms *contact make* or *contact break* apply to the electrical circuits between a pair of contacts. Contact make may involve closing of only one pair of contacts. Contact break involves the opening of both pairs of contacts.

SECTION 040-505-701

1.11 A pretensioned *spring* is a spring which has been preformed during manufacture. Such a spring may be recognized by one or more distinct bends in the spring to provide the necessary tension. In the case of contact springs, the bends should not be disturbed.

1.12 *Armature gap* is the gap between the core and armature in any position the armature may assume between its unoperated and operated positions.

1.13 *Operate*: The relay is said to operate if, when current is connected to its winding, the armature moves sufficiently to meet the following conditions.

- (a) All normally open contacts close and all normally closed contacts open.
- (b) The embossed surface of the armature rests against the core.
- (c) The armature remains in the operated position until a current in a direction opposite that which caused the relay to operate is applied to the winding.

1.14 *Nonoperate*: A relay is said to nonoperate if, when the relay is held operated by the residual magnetism of the core and the specified nonoperate (reverse) current is connected to its winding, the relay releases and does not reoperate.

1.15 *Hold*: A relay is said to hold if, after the relay has been operated on its soak or operate current and the current is reduced to the hold value and reversed in direction, the armature does not move from the operated position.

1.16 *Latch*: The relay is said to latch if, after the relay has been operated on its soak or operate current and the current is reduced or stopped, the armature does not move from the operated position.

1.17 *Release*: The relay is said to release if, when current is applied to its winding in a direction opposite that which caused the relay to operate, the armature moves from the core to its unoperated position in which the armature is resting against its backstop and all normally open contacts are open and all normally closed contacts are closed.

1.18 *Soak Current*: The soak current is that current applied to the relay coil to insure that the current flow requirements are always applied with a known magnetic condition of the core.

1.19 *No-Flux Current*: The no-flux current is that current applied in a direction opposite that which caused the relay to operate which, when connected to the relay coil after the soak current has been connected to and removed from the coil, will restore the core to the zero-flux state.

1.20 *Use of the 510C Portable Lamp*: The 510C portable lamp, equipped with a 561A straight tip, may be used to facilitate gauging and adjustment operations.

1.21 *Use of Buffer Springs (AL-type relays only)*

(a) If the spring combination number shown in the "BSP Fig." column on the circuit requirements table is followed by the letter B, the associated relay may be equipped with a buffer spring if this is necessary to meet the electrical release requirements. These relays are equipped with a buffer spring during manufacture, only if the buffer spring is found to be necessary during factory adjustment of the relay.

(b) The buffer springs for the AL-type relays are furnished in two thicknesses, 0.012 inch and 0.016 inch. In most cases where a buffer spring is required, the 0.012-inch thick spring is adequate for meeting the electrical release timing requirements but in a few cases use of the 0.016-inch spring is necessary. For identification, the 0.012-inch thick spring (P-16A279) is stamped 1 and the 0.016-inch thick spring (P-16A070) is stamped 2 in the position indicated in Fig. 1.

2. REQUIREMENTS

2.01 *Cleaning*: The contacts and other parts of the relay shall be cleaned when necessary in accordance with Section 069-306-801. After cleaning the contacts, a check shall be made to see that the movable twin springs are positioned as specified in requirement 2.08. Also a check shall be made that contacts which were cleaned, meet requirements 2.09, and 2.10.

Note: If the armature and core of the relays are not clean and free of magnetic and nonmagnetic particles, the relay may not latch or, in the case of AM-type relays, the relay may fail to remain latched after the other half of the relay has been operated and released several times.

2.02 Relay Mounting: The relay shall be fastened securely to the mounting plate.

Gauge by feel by applying the KS-6320 orange stick to the upper- and lower-right corners of the core plate.

2.03 Vertical Clearance: The clearance between the relay and apparatus mounted directly above or below shall be:

Min 1/16 inch

Gauge by eye.

2.04 Contact Cover Tightness: Fig. 1(A)—The contact cover shall be held firmly in place.

Gauge by feel.

2.05 Armature Position (AL-type relay):

Fig. 3(A)—The armature hinge spring legs, where they are secured to the armature legs, shall bear against the outer legs of the core with the relay in the operated and unoperated positions. Operate the relay electrically and gauge by eye.

2.06 Balancing Spring Tension: Fig. 2(C) and 3(B)—With the relay in the unoperated position, the combined tension of the balancing spring legs shall be sufficient to hold the card against the associated surfaces on the armature and the armature against its backstop. (See requirement 2.07.)

Note: Before checking the balancing spring tension, apply the soak current and then the no-flux current specified for the relay in requirement 2.13.

Gauge the position of the card and armature by eye and feel.

2.07 Armature Back Tension: Fig. 2(A) and 4(A)—The armature shall bear against its backstop with a pressure of:

RELAY	TEST (grams)	READJUST (grams)
AL-1 Type	After a negative soak of -0.300 amps and a no-flux release of $+0.0435$ amps, the armature should rest against the backstop surface of the core plate with a force of about 100 grams.	
AL-2 Type	Min 25, no Max	Min 30, No Max
AM Type	Min 35, Max 115	Min 40, Max 110

Note: Before checking the armature back tension, apply the soak current and then the no-flux current specified for the relay in the circuit requirements table.

Use the 62B or 70J gauge as follows. On AL-type relays, apply the gauge to the tip of the armature as shown in Fig. 4(A). On AM-type relays, apply the gauge to the armature in front of the armature backstop as shown in Fig. 2(A), making sure that the gauge clears the backstop and magnetic shield.

2.08 Movable Twin Contact Spring Position:

Fig. 5(A) and 6(A)—The twin springs of a movable pair shall be in the respective comb grooves associated with the position on the relay in which the springs are mounted.

Gauge by eye.

2.09 Contact Make and Break (see Tables A and B)

(a) Both contacts of the movable twin springs shall make with their associated single contact on the fixed spring in the electrically operated position of the relay for normally open contacts and in the unoperated position for normally closed contacts.

Gauge by eye and feel.

(b) With the relay electrically energized against a gauge of the thickness indicated in (1), (2), or (3) below inserted in the armature gap except in the cases (#) covered in (2), the following conditions shall be met.

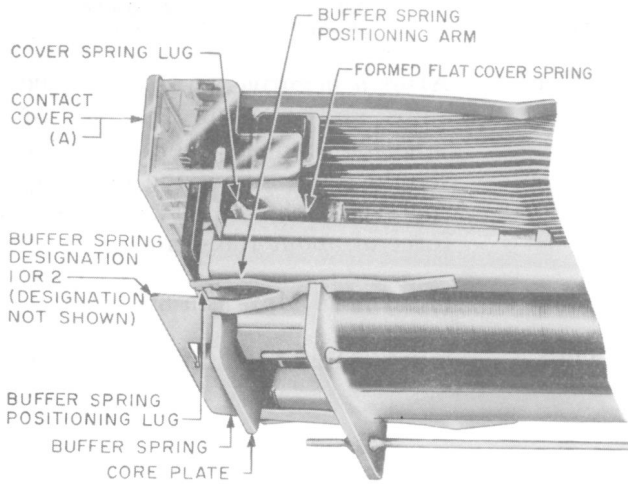

Fig. 1—AL Type Relay Showing Contact Cover and Buffer Spring

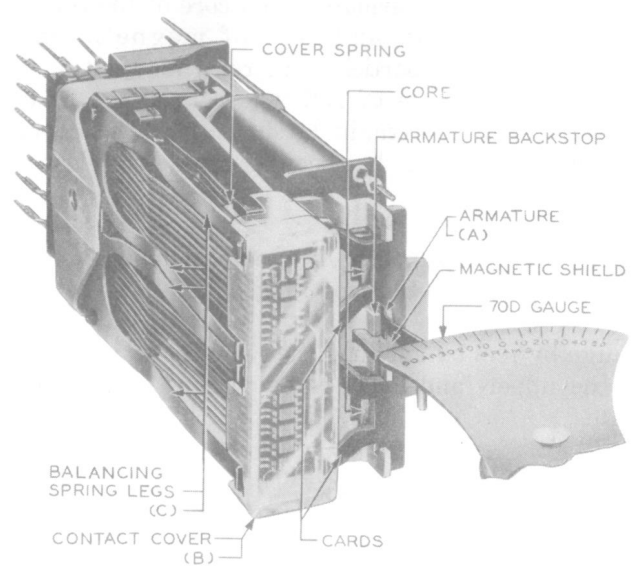

Fig. 2—AM Tye Relay-Gauging Armature Back Tension

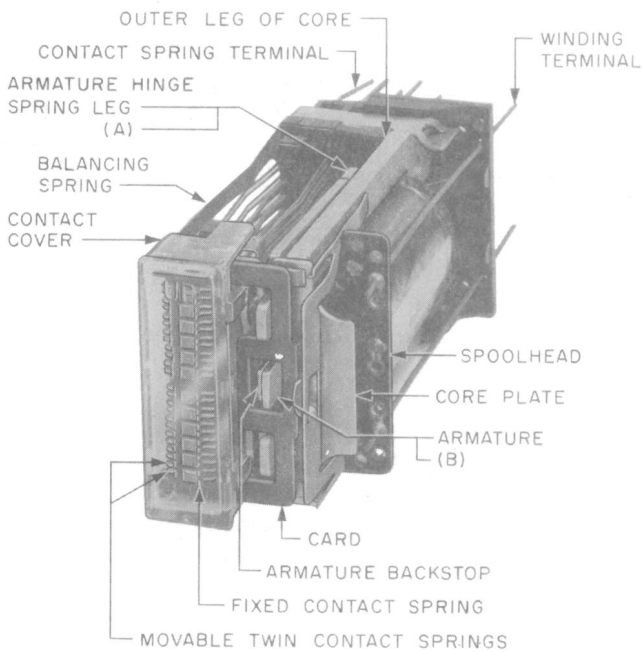

Fig. 3—AL Type Relay Showing Armature Position

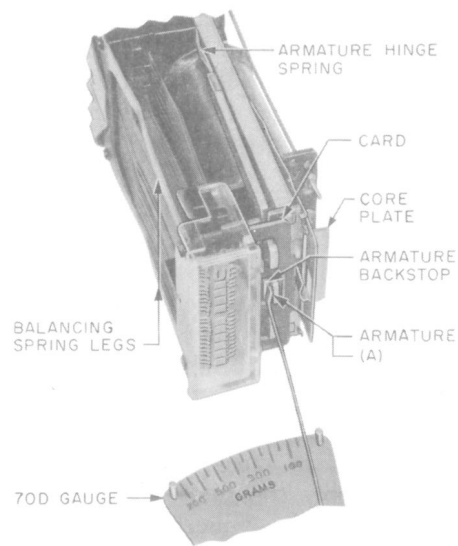

Fig. 4—Method of Checking Armature Back Tension for AL Type Relay

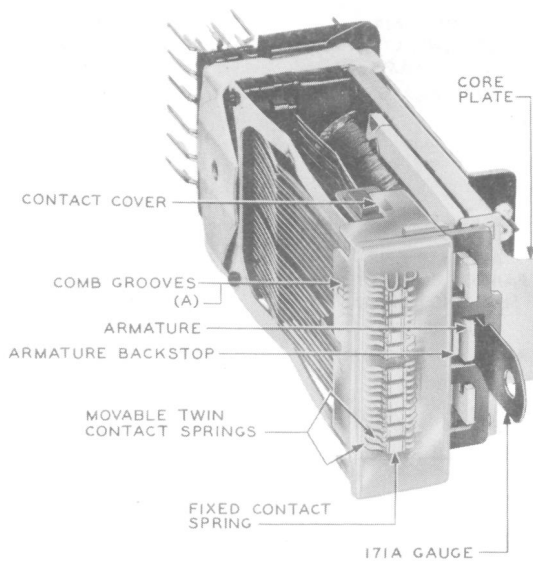

Fig. 5—Method of Inserting Gauge In AL-Type Relay

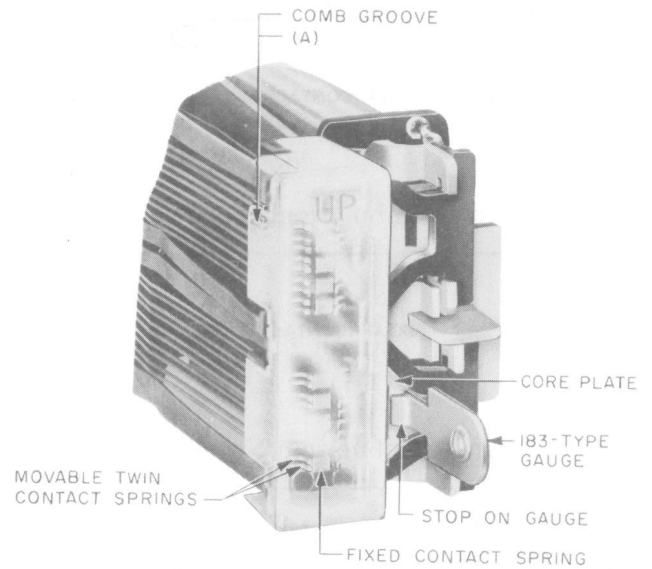

Fig. 6—183-Type Gauge Inserted In Armature Gap of AM-Type Relay

Test

(1) *Before Turnover*

MAKE CONTACTS	NEITHER PAIR OF CONTACTS SHALL MAKE TYPE RELAYS		AT LEAST ONE PAIR OF CONTACTS SHALL MAKE TYPE RELAYS	
	AL (inch)	AM	AL (inch)	AM
M (make or make of BM)	0.0135	0.0165	0.003	0.0035
M (make of EBM)	—	—	0.003	0.0035
EM (early make of EMB)	0.023	0.028	—	—
BREAK CONTACTS	AT LEAST ONE PAIR OF CONTACTS SHALL NOT BREAK TYPE RELAYS		BOTH PAIRS OF CONTACTS SHALL BREAK TYPE RELAYS	
	AL (inch)	AM	AL (inch)	AM
B (break or break of BM)	0.0135	0.0165	0.003	0.0035
B (break of EMB)	—	—	0.003	0.0035
EB (early break of EBM)	0.023	0.028	—	—

AL-Type Relays: Use 171A gauge and check as covered in (c).

AM-Type Relays: Use 183-type gauge and check as covered in (c).

(2) *After Turnover*

MAKE CONTACTS	NEITHER PAIR OF CONTACTS SHALL MAKE TYPE RELAYS		AT LEAST ONE PAIR OF CONTACTS SHALL MAKE TYPE RELAYS	
	AL (inch)	AM	AL (inch)	AM
Spring Combination No. 200 to 399	#0.007	#0.007	†0.0015	†0.0015

BREAK CONTACTS	AT LEAST ONE PAIR OF CONTACTS SHALL NOT BREAK TYPE RELAYS		BOTH PAIRS OF CONTACTS SHALL BREAK TYPE RELAYS	
	AL (inch)	AM	AL (inch)	AM
Spring Combination No. 200 to 399	#0.007	#0.007	†0.0015	†0.0015

AL-Type Relays

Use 171A gauge inserted between armature and backstop and check as covered in (d).

† Use 171A gauge as covered in (c).

AM-Type Relays

Use 182-type gauge inserted between armature and backstop and check as covered in (d).

† Use 183-type gauge as covered in (c).

Readjust

(3) *Before and After Turnover*

MAKE CONTACTS	NEITHER PAIR OF CONTACTS SHALL MAKE TYPE RELAYS		AT LEAST ONE PAIR OF CONTACTS SHALL MAKE TYPE RELAYS	
	AL (inch)	AM	AL (inch)	AM
M (make)	0.012	0.015	0.0045	0.005
EM (early make)	0.0215	0.0265	0.0135	0.0165

	AT LEAST ONE PAIR OF CONTACTS SHALL NOT BREAK TYPE RELAYS		BOTH PAIRS OF CONTACTS SHALL BREAK TYPE RELAYS	
	AL (inch)	AM	AL (inch)	AM
B (break)	0.012	0.015	0.0045	0.005
EB (early break)	0.0215	0.0265	0.0135	0.0165

AL-Type Relays: Use 171A gauge as covered in (c).

AM-Type Relays: Use 183-type gauge as covered in (c).

(c) To check the requirements where the gauge is to be inserted in the armature gap, electrically operate and release the relay (see requirement 2.13). Insert into the armature gap the specified gauge of the proper thickness with the stop on the gauge resting against the core plate as shown in Fig. 5 and 6. Hold the gauge so that its long axis is in a horizontal position and the gauge does not touch the card. Then electrically energize the relay and note whether the contacts are open or closed as required. When a gauge is inserted in the armature gap of the relay, the relay may release when the current is removed from the winding; therefore, at least minimum operate current must remain applied to the winding to keep the relay electrically energized while checking the requirement on the relay. In case of doubt as to whether the contacts are open or closed, remove the contact cover and apply the KS-6320 orange stick to the tips of the twin contact springs. Attempt to move them toward their mating single contact as shown in Fig. 7 and 8. Observable movement of either twin contact indicates that the contact is not closed.

(d) To check the requirements where the gauge is to be inserted between the armature and its backstop, electrically operate the relay. Insert into the gap between the armature and backstop the specified gauge of proper thickness in accordance with (1) through (3).

(1) **AL-Type Relays:** Take care that the front edge of the gauge rests against the core plate as shown in Fig. 9. Make sure that the long axis is horizontal and that the gauge is not inserted beyond the front of the core plate.

(2) **AM-Type Relays:** Take care that the stop on the gauge rests against the armature as shown in Fig. 10. Make sure that the long axis of the gauge is in a horizontal position.

(3) Release the relay and note whether the contacts are open or closed as required. In case of doubt as to whether the contacts are open or closed, check with the orange stick as covered in (c).

(e) If the circuit requirements table specifies insulating contacts on the relay being checked or adjusted, it will be satisfactory when checking for contact make or break to remove the paper insulator. In this case, it may be necessary to open the contacts manually with a toothpick to release the relay.

(f) After checking the contact make and break requirement, apply the soak current and then the no-flux current specified for the relay in requirement 2.13.

2.10 Contact Sequence (see Tables A and B)

Test

(a) **EMB (early make break) Position:** The EM contacts of each EMB position shall make before the B contacts break.

Operate the relay manually and gauge by eye.

(b) **EBM (early break make) Position:** The EB contacts of each EBM position shall break before the M contacts make.

Operate the relay manually and gauge by eye.

(c) **BM (break make) Position:** No requirement.

**TABLE A—AL-TYPE RELAYS—SPRING COMBINATION
FIGURE NUMBER AND CONTACT POSITIONS**

CONTACT POSITIONS	Spring Combination Figure Number	
	AL-1 CODE 299	AL-2 CODE 336
12	EBM	EBM
11	EMB	EMB
10	EBM	EBM
9	EMB	EMB
8	EBM	EBM
7	BM	EMB
6	EBM	EBM
5	BM	EMB
4	EBM	EBM
3	EMB	EMB
2	EBM	EBM
1	EMB	EMB

BM — Break Make
 EBM — Early Break Make
 EMB — Early Make Break

} See Reqt
 } 2.09 and 2.10

**TABLE B—AM-TYPE RELAYS—SPRING COMBINATION
FIGURE NUMBER AND CONTACT POSITIONS**

CONTACT POSITIONS	Spring Combination Figure Numbers	
	AM-1 AND AM-3 CODE 216	AM-2 AND AM-4 CODE 222
12	EBM	EBM
11	EBM	EBM
10	EBM	EBM
9	EMB	EBM
8	EMB	EBM
5	EMB	EBM
4	EMB	EBM
3	EBM	EBM
2	EBM	EBM
1	EBM	EBM

EBM — Early Break Make (See Reqt
EMB — Early Make Break (2.09 and 2.10

Readjust

(d) No requirement. Readjust requirements for contact make and break [requirement 2.09(b) (3)] to insure the required sequences.

2.11 Buffer Spring Position (AL-type relay)

(a) If the use of a buffer spring (see 1.20) is necessary, the portion of the positioning arm between the two positioning lugs shall rest against the core plate in both the unoperated and operated positions of the relay.

(b) The buffer spring shall meet the following conditions with the relay electrically energized against a gauge of the thickness indicated below inserted into the armature gap.

NO MOVEMENT OF BUFFER SPRING (inch)	PERCEPTIBLE MOVEMENT OF BUFFER SPRING (inch)
--	--

Test

Before Turnover	0.0085	0.0015
After Turnover	—	0.0015

Readjust	0.007	0.003
-----------------	-------	-------

Use the 171A gauge.

To check this requirement, first operate and release the relay. Insert into the armature gap a 171 gauge of the proper thickness. Take care that the long axis of the gauge is in a horizontal position and that the shoulders of the gauge rest against the core plate of the relay as shown in Fig. 5. Electrically energize the relay and note whether there is movement of the buffer spring as observed at the rib in the spring shown in Fig. 11.

Note: After checking the buffer spring position requirement on AL-type relays, apply the soak current and then the no-flux current specified for the relay in the circuit requirements table.

(c) If the relay is equipped with a buffer spring and the buffer spring is not used, there shall be a gap between the operating lug on the buffer spring and the card when the relay is in the operated position.

Gauge by eye.

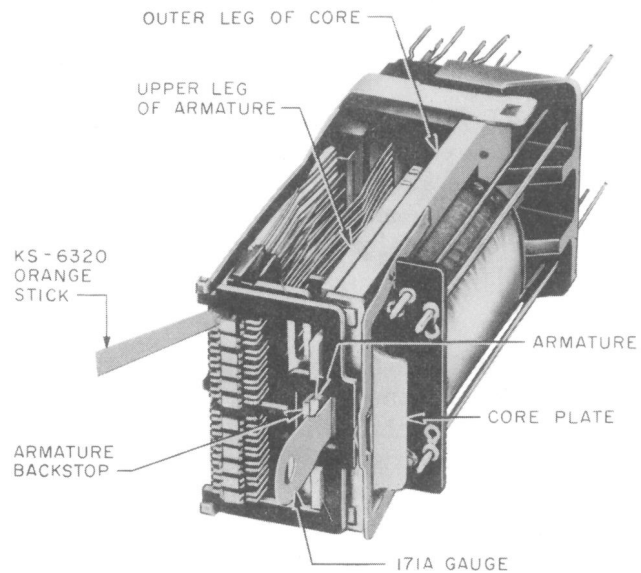

Fig. 7—Method of Checking Open or Closed Contacts of AL-Type Relay

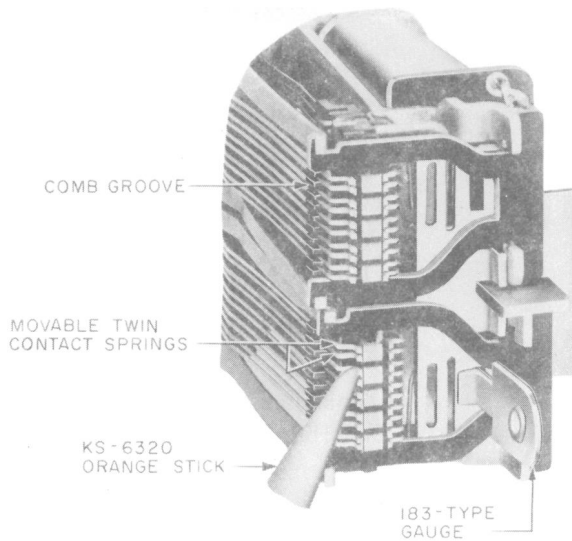

Fig. 8—Method of Checking Open or Cloed Contacts of AM-Type Relay

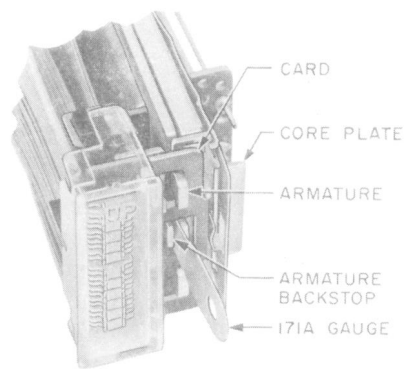

Fig. 9—Gauge Inserted Between Armature and Armature Backstop of AL-Type Relay

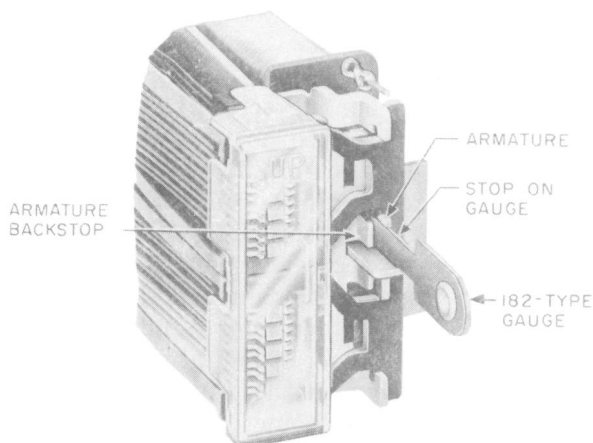

Fig. 10—182-Type Gauge Inserted Between Armature

2.12 Buffer Spring Tension (AL-type relay):

With the relay in the unoperated position, the tension of the buffer spring against the center leg of the core shall be:

Test—Min 20 grams

Readjust—Min 25 grams

Use the 70D gauge applied adjacent to the operating lug as shown in Fig. 11.

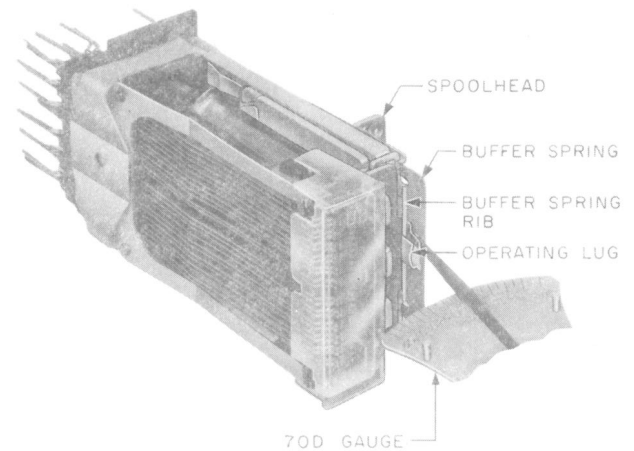

Fig. 11—Method of Checking Buffer Spring Tension

2.13 Electrical Requirements: The relay shall meet the electrical requirements specified on the circuit requirements table.

Note: If a hold requirement is specified on the circuit requirements table to control the minimum release time, the requirement is considered met if, after the relay has operated and the current is reduced abruptly to the hold value, the armature remains in the operated position for at least 2 seconds. The period of 2 seconds may be judged satisfactorily by saying "one hundred and fifty-five," pronouncing each syllable fully and distinctly.

2.14 Timing Requirements: When specified on the circuit requirements table, the relay shall meet the times specified.

2.15 Latching Force (AM-type relay only):

With the relay in the latched position, the force required to mechanically release the relay shall be

SECTION 040-505-701

Test—Min 140 grams

Readjust—Min 150 grams

Use the 62B gauge

Note: The specified latching forces apply after the side of the relay to be checked is pulsed onced (operated and released) and then latched and the other side is then pulsed for approximately 100 cycles.

To check the requirement, demagnetize the relay (soak and no-flux) and then apply the operate current. Press the 62B gauge against the card midway between the armature legs and slowly increase the pressure until the relay releases.

3. ADJUSTING PROCEDURES

3.001 List of Tools, Gauges, Materials, and Test Apparatus

CODE OR SPEC NO.	DESCRIPTION
TOOLS	
363	Spring adjuster
510C	Portable lamp [equipped with 561A straight tip and W2CB (24V) or W2BL (48V) cord]
◆534J◆	Spring adjuster (0.018-inch balancing spring)
534G	Spring adjuster (0.020- and 0.025-inch balancing springs)
535A	Spring adjuster
628A	Balancing spring lifter
KS-6320	Orange stick
◆768A◆	Armature blocking tool
R-2753	Adjuster
—	4-Inch E-screwdriver
—	D screwdriver

CODE OR SPEC NO.	DESCRIPTION
GAUGES	
62B	0-700 Gram gauge
70D	50-0-50 Gram gauge
70J	0-150 Gram gauge
171A	Thickness gauge nest
184A	Thickness gauge nest (consists of 182- and 183-type gauges)
MATERIALS	
—	Toothpicks, hardwood, flat at one end and pointed at the other

TEST APPARATUS

35 Type Test set

3.01 Cleaning (Reqt 2.01)

(1) Clean the contacts and other parts of the relay in accordance with Section 069-306-801. Before cleaing the armature and core, apply the soak current and ten the nonflux current specified for the relay on the circuit requirements table. After cleaning, check that requirements 2.08, 2.09, and 2.10 are met.

3.02 Relay Mounting (Reqt 2.02)

3.03 Vertical Clearance (Reqt 2.03)

(1) To tighten mounting screws, use the 4-inch E screwdriver. To position the relay on the mounting plate, slightly loosen the mounting screws of the relay with the 4-inch E screwdriver and shift the relay as required. Retighten the mounting screws securely, taking care that the relay is in proper alignment and that there is the specified clearance above and below the relay. To retighten the mounting screws of relays equipped with the flexible mounting assembly, tighten the mounting screws until they are snug, then loosen the screws two-thirds of a turn.

3.04 Contact Cover Tightness (Reqt 2.04)

- (1) To tighten the contact cover, use the R-2753 adjuster as follows. Holding the adjuster at approximately a 45-degree angle, place the end having the narrower slot over one of the lugs of the cover spring and bend the lug slightly toward the molded section to increase the cover tightness or slightly away to decrease it. Make an approximately equal adjustment on the other lug. Mount the cover and, if it does not meet the requirement, repeat the procedure.

3.05 Armature Position (AL-type relay) Reqt 2.05)

- (1) If the requirement is not met, remove the balancing spring legs from the card as covered in 3.06 and 3.07(1) and (3). Then, measure the tension of the two legs of the balancing spring as described in 3.06 and 3.07(4). If the tension of the two legs is not approximately equal, adjust as covered in 3.06 and 3.07(5) through (7). If after making this adjustment the requirement is still not met in both the operated and unoperated positions of the relay, the trouble may be due to distortion of the armature hinge spring. In this case, refer the matter to the supervisor.

3.06 Balancing Spring Tension (Reqt 2.06)**3.07 Armature Back Tension** (Reqt 2.07)

- (1) **AL-Type Relays:** If the balancing spring legs do not hold the card against the associated surfaces of the armature or if the armature does not bear against the armature backstop with the specified pressure, block the relay operated using the 768A tool. Then, remove the top and bottom legs of the balancing spring from the card as covered in (3) and proceed as covered in (4) through (7).
- (2) **AM-Type Relays:** If the balancing spring tension or armature back tension requirements are not met for the upper half of the relay, block the relay operated using the 768A tool. Then, remove the top leg of the balancing spring from the card as covered in (3). Similarly, if the requirements are not met for the lower half of the relay, block the relay operated and remove the bottom leg from the card as covered in (3). Do not attempt to remove the two legs of the balancing spring at the middle of the relay.

After removing the leg from the card as covered in (3), proceed as covered in (5) through (7).

- (3) To remove the top leg of the balancing spring from the card, hold the 628A balancing spring lifter in the left hand and insert the lifter next to the upper leg of the balancing spring with the end of the lifter just behind the comb. Roll the end of the lifter under the leg of the spring so that it rests in the groove of the lifter. Then draw the lifter forward to the position shown in Fig. 12 and 13. With the other hand, place the end of a KS-6320 orange stick on the top edge of the card to the right of the balancing spring leg as shown in Fig. 12 and 13. Lift the leg of the spring upward with the tool and at the same time press the card downward with the orange stick. When the spring clears the top of the card, move it toward the left so that it is free of the card. Withdraw the spring lifter. When removing the lower leg of the spring, the procedure is the same except that the opposite end of the spring lifter is rolled over the top edge of the leg and pushed downward while the orange stick is pressed upward against the bottom edge of the card.

- (4) For AL-type relays, measure the tension of the balancing spring legs as follows. Insert the tip of the 70J gauge between the two projections at the front end of the leg of the spring and move the spring toward the right until it touches the edge of the card as shown in Fig. 14. With the spring in this position, read the tension on the gauge. If there is considerable difference between the tension of the balancing spring legs, adjust the leg having the lower tension to a value approximately equal to that of the other leg using the proper spring adjuster as covered in (6), (7), and (8). If the requirements are still not met, increase or decrease the tension of both legs as required.

- (5) The legs of the balancing spring are pretensioned; therefore, do not attempt to remove the bends in the legs since this would make it impossible to obtain a satisfactory tension adjustment. Take care not to slide or draw the spring adjuster over a bend in a pretensioned spring.

- (6) To adjust the balancing spring legs for tension, use the 534J spring adjuster for 0.018-inch springs and the 534G spring adjuster for 0.020- and 0.025-inch springs.

(7) Place the slotted portion of the proper spring adjuster on the leg of the balancing spring just in back of the two projections at the end of the leg. Slide the adjuster back until the end of the insulation on the handle is in line with the end of the spring. This will bring the slotted portion of the adjuster close to the pretensioned bend in the spring as shown in Fig. 15 and 16. With the adjuster in this position, bend the spring to the left to increase the tension while maintaining a pressure on the adjuster toward the right. This pressure on adjuster is necessary in order to avoid distorting the portion of the balancing spring leg to the rear of the pretensioned bend. If necessary to decrease the tension to meet the requirements, bend the spring to the right while maintaining a pressure on the adjuster toward the left. Take care when adjusting the legs of the spring to adjust them in line with their movement and to avoid

tilting. Do not adjust more than necessary since repeated adjustment may injure the spring.

3.08 Movable Twin Contact Spring Position
(Reqt 2.08)

(1) If one of the twin springs of a pair overlies the other, the overlying spring is not in its proper groove in the comb. If there is a greater space between the contacts of a twin pair compared to that between contacts on other twin pairs, this is an indication that these springs are crossed and not in their respective grooves. In both cases, position the springs in their respective grooves using the KS-6320 orange stick applied to the tips of the springs. If the springs cannot be properly positioned, refer to the matter to the supervisor.

3.09 Contact Make and Break (Reqt 2.09)

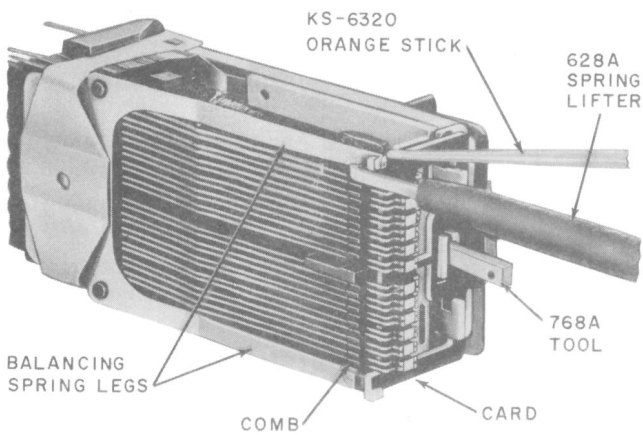

Fig. 12—Method of Removing Balancing Spring Legs from Cords—AL-Type Relay

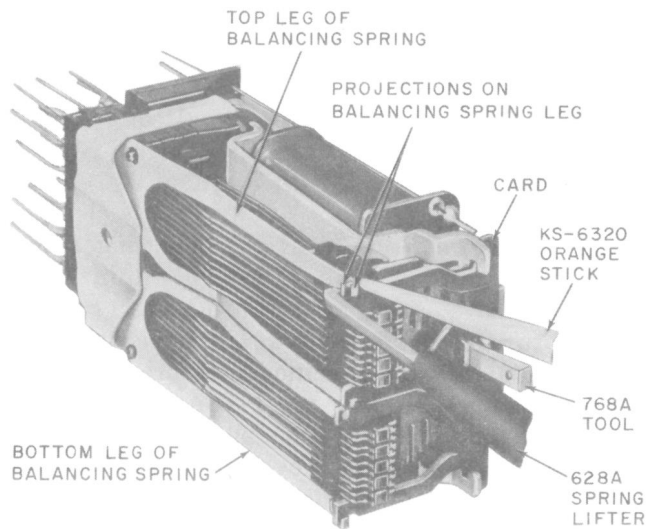

Fig. 13—Method of Removing Balancing Spring Leg From Cord—AM Type Relay

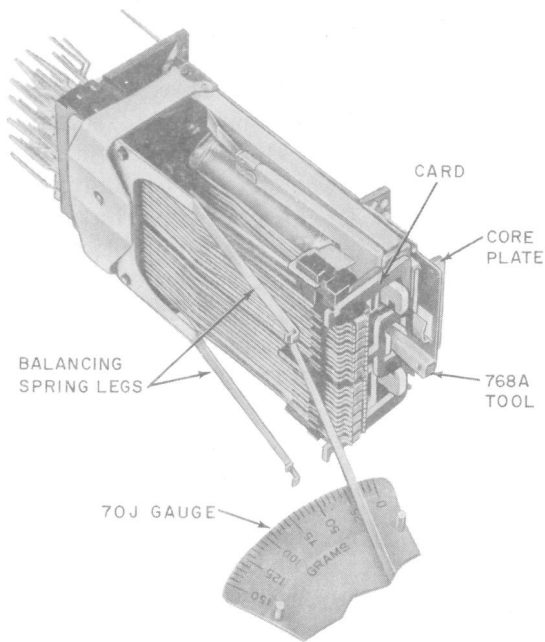

Fig. 14—Method of Checking Balancing Spring Tension

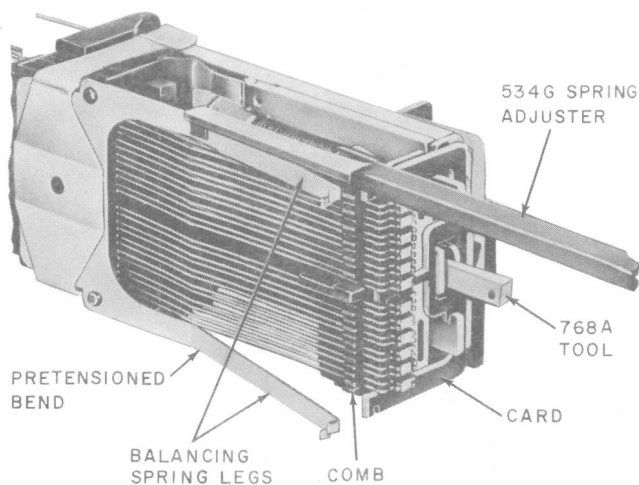

Fig. 15—Method of Adjusting Balancing Spring Tension—AL-Type Relay

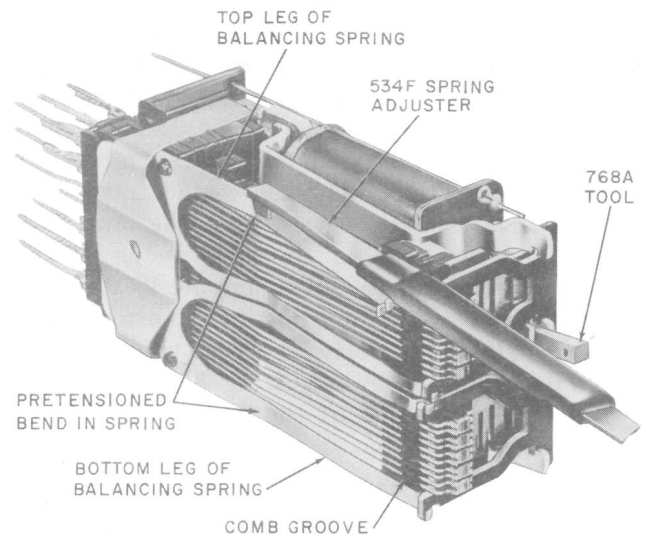

Fig. 16—Method of Adjusting Balancing Spring Tension—AM-Type Relay

3.10 Contact Sequence (Req't 2.10)

(1) Adjustments to meet the contact make and break requirements are made by adjusting the upper and lower portions of the core plate to reposition the outer ends of the fixed contact springs which are supported in the front molded section. Since this molded section rests against the top and bottom of the core plate only, adjustment of either the upper or lower portion of the core plate will change the position of the fixed contacts in an inverse ratio to their distances from the top and bottom of the core plate, respectively. Thus, adjustment of the lower portion of the core plate will have the greatest effect on the position of the fixed contact in position 1 (lower half of relay) and negligible effect on the contact in position 12 (upper half of relay). This relation should be taken into account when making adjustments for contact make and break in either half of the relay and the adjustment should be made on either one or both portions of the core plate in order to obtain the required result with as little bending of either portion as practicable.

(2) **Contact Make:** To adjust for contact make, insert the D screwdriver as shown in Fig. 17 for AL-type relays or per Fig. 18 for AM-type into either the upper or lower adjusting slot in the core plate depending on whether the contacts to be adjusted are in the upper or lower half of the relay. To increase the separation between the movable break and fixed contacts, twist the screwdriver slightly clockwise in the lower slot and counterclockwise in the upper. If the contacts that require adjustment are located near the bottom of the upper half or the top of the lower half of the relay, the best adjustment is usually obtained by adjusting both the upper and lower portions of the core plate. After completing the adjustment, recheck the contact make and break and contact sequence requirements for both the upper and lower halves of the relay.

Caution: Use of any but the proper screwdriver will spread the slots in the core plate and adversely affect future adjustability of the relay.

(3) **Contact Break:** To adjust for contact break, insert the D screwdriver as shown

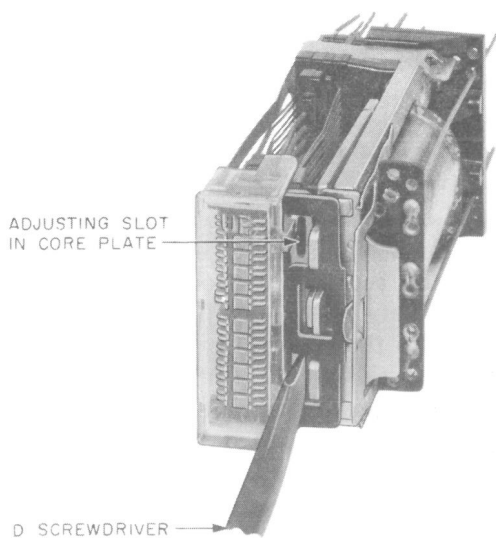

Fig. 17—Method of Adjusting Contact Separation
AL-Type Relay

in Fig. 17 for AL-type relays or per Fig. 18 for AM-type into either the upper or lower adjusting slot in the core plate, depending on whether the contacts to be adjusted are in the upper or lower half of the relay. To increase the separation between the movable break and fixed contacts, twist the screwdriver slightly clockwise in the lower slot and counterclockwise in the upper. If the contacts that require adjustment are located near the bottom of the upper half or the top of the lower half of the relay, the best adjustment is usually obtained by adjusting both the upper and lower portions in the core plate. After completing the adjustment, recheck the contact make and break and contact sequence requirements for both the upper and lower halves of the relay.

(4) Failure to meet contact make or break requirements after adjusting as covered in (1) through (3) may be due to a worn card. In this case, replace the card.

(5) **Contact Sequence:** To adjust for contact sequence, proceed as covered in (1) through (4).

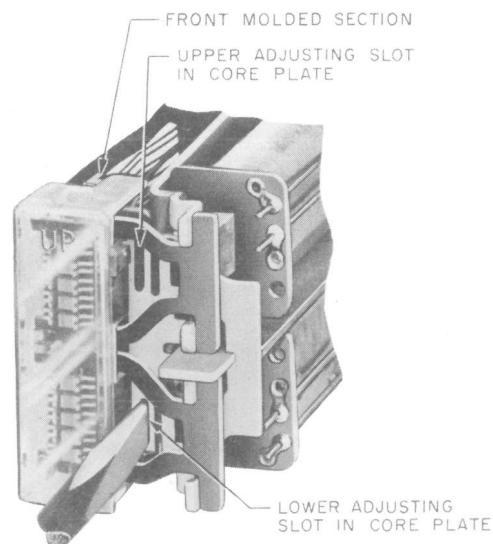

Fig. 18—Method of Adjusting Contact Separation—
AM-Type Relay

3.11 Buffer Spring Position (AL-type relay)
(Reqt 2.11)

3.12 Buffer Spring Tension (AL-type relay)
(Reqt 2.12)

(1) If a relay on which the use of a buffer spring is permitted by the circuit requirements table (see 1.20) is not equipped with a buffer spring but a buffer spring is required to meet the electrical release requirements, mount a P-16A279 (0.012-inch thick) buffer spring as covered in Section 040-502-801. Position the buffer spring as covered in (3) and adjust the tension as covered in (4). If the 0.012-inch thick buffer spring is inadequate to meet the electrical timing requirements, substitute a P-16A070 (0.016-inch thick) buffer spring and adjust the position as covered in (3) and (4).

(2) If the relay is equipped with a buffer spring but the buffer spring is not positioned properly or if the buffer spring has not been used previously but is now required, position it as covered in (3). Then adjust its tension as covered in (4).

(3) Place the 363 spring adjuster on the operating lug of the buffer spring so that the middle of the lug is in the slot of the adjuster as shown in Fig. 19. Bend the lug as required. Exercise care not to adjust the lug more than necessary since repeated adjustments may injure the lug.

(4) To change the tension of a buffer spring, place the 535A spring adjuster on one of the legs of the buffer spring so that the spring is in the slot of the adjuster. Slide the adjuster back toward the spoolhead to approximately the position shown in Fig. 20. To increase the tension, bend the spring toward the left. To reduce the tension, bend the spring toward the right. In making this adjustment, keep the buffer spring approximately parallel to the edge of the core plate by distributing the tension between the upper and lower legs of the spring. Take care not to disturb the pretensioned bends. Do not attempt to obtain the required tension by one adjustment. Increase the tension gradually to avoid excessive kinking of the spring which would make further adjustment difficult. Recheck the buffer spring position requirement.

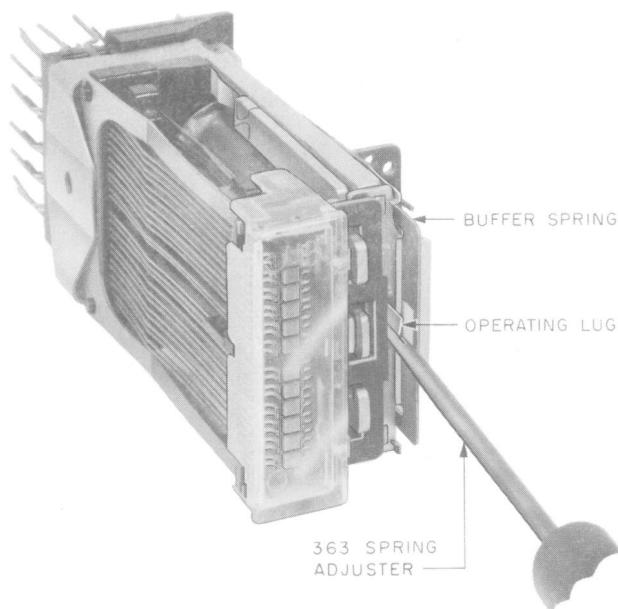

Fig. 19—Method of Positioning Buffer Spring

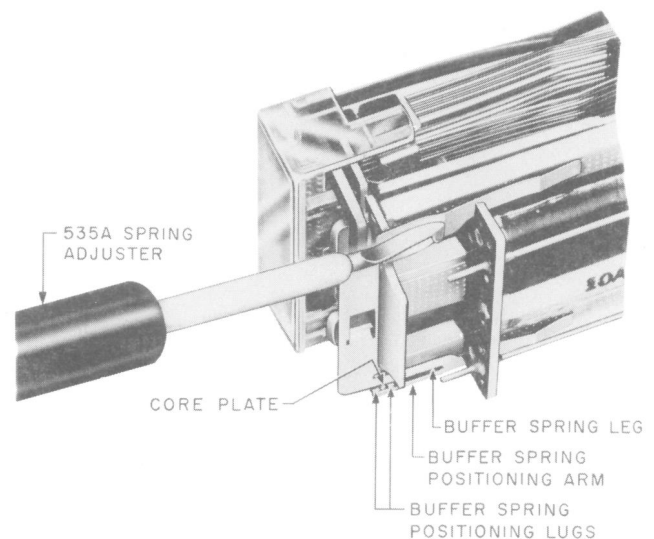

Fig. 20—Method of Adjusting Buffer Spring Tension

SECTION 040-505-701

3.13 *Electrical Requirements* (Reqt 2.13)

- (1) To meet the operate requirement, decrease the tension in the balancing spring legs. If the requirement still cannot be met, check that requirement 2.05 is met and, if it is not, refer the matter to the supervisor.
- (2) To meet a hold requirement, if specified, decrease the tension in the balancing spring legs. If the relay is equipped with a buffer spring and the buffer spring is being used, it is preferable to decrease the tension of the buffer spring or remove the spring than to decrease the balancing tension too much.
- (3) To meet a nonoperate requirements, if specified, increase the tension of the balancing spring legs to hold the armature against the armature backstop.
- (4) To meet the release requirement, increase the tension of the balancing spring legs. Adjust the relays to release on as high a current as possible consistent with meeting operate and hold requirements. If the circuit requirements table permits the use of a buffer spring (see 1.11 and 3.13), it is desirable to use the buffer spring in conjunction with the balancing spring. If the use of a buffer spring is not permitted, adjust the tension of the balancing spring as high as possible consistent with meeting operate and hold requirements.

- (5) If the buffer spring is used and the relay fails to operate when the buffer spring is picked up, check for buffer spring position (requirement 2.13) and correct if necessary. If the relay still fails to operate, decrease tension in the buffer spring legs are required.

3.14 *Timing Requirements* (Reqt 2.14)

- (1) If the timing requirements cannot be met with the relay adjusted within the requirements covered in this section, replace the relay.

3.15 *Latching Force (AM-type relay only)* (Reqt 2.15)

- (1) The adjusting procedure for meeting the latching force requirement involves adjustment of the balancing spring legs. This adjustment is similar to the adjustments for armature back tension and balancing spring tension. When adjustments are made for one of these requirements, the adjustments for the other requirement may be affected.
- (2) If either half of the relay does not meet the latching force requirement, proceed as follows. Check requirement 2.01 covering cleaning. Then, adjust the armature back tension as necessary to meet the latching force requirement. To do this, apply the adjusting procedures for meeting the armature back tension requirement as covered in 3.07(2) except check for the latching force requirement.