

**BL- AND BM-TYPE RELAYS**  
**(MAGNETIC LATCHING WIRE-SPRING)**  
**TIMING TESTS USING J94735A TEST SET**

CONTENTS	PAGE
1. GENERAL . . . . .	1
2. PRETEST PROCEDURES . . . . .	2
3. METHOD OF CONNECTING THE J94735A TEST SET . . . . .	2
4. RELAY TESTS . . . . .	2

**1. GENERAL**

**1.01** This section covers timing tests of BL- and BM-type wire-spring magnetic latching relays when used in circuits having circuit requirements tables specifying that this section applies.

**1.02** Whenever this section is reissued, the reason for reissue will be listed in this paragraph. This issue affects the Equipment Test List.

**1.03** Magnetic latching relays differ from other wire-spring types in the core material used. The magnetic latching relay remains magnetized after the operate voltage is removed and will hold the relay in an operate condition until the application of a release voltage.

**1.04** The BL-type relay (Fig. 1) has a 6-position contact arrangement. The BM-type relay (Fig. 2) has a 12-position contact arrangement.

**1.05** The plastic dust cover over the contacts of wire-spring relays should not be removed unless the test being made requires its removal. If the cover is removed, it should be replaced as soon as practicable. Make sure that the letters UP on the plastic surface are on top and that the cover does not interfere with the card or contact springs.

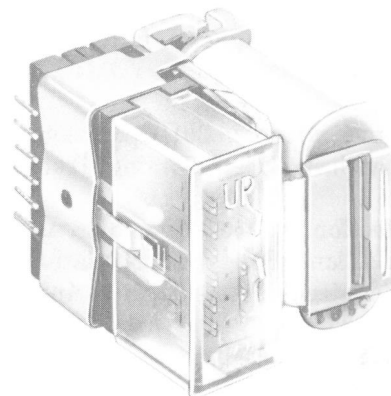

**Fig. 1—BL-Type Relay, General View**

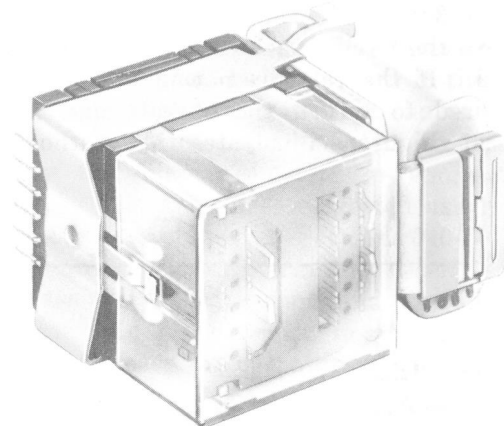

**Fig. 2—BM-Type Relay, General View**

**Note 1:** Do not attempt to interchange the covers of the BL-type relays with those of the BM-type.

**NOTICE**

Not for use or disclosure outside the  
Bell System except under written agreement

**Note 2:** Reference should be made to the J drawing covering the equipment being tested. If a vibration damper assembly is specified, it must be in place during these tests.

**1.06** In addition to this section, the following sections will be required for the tests covered in this practice:

Section 100-136-701, Calibration of the J94735A Magnetic Latching Relay Timing Test Set

Section 100-136-301, Operation of the Magnetic Latching Relay Timing Test Set

Section 040-507-701, Relays BF-, BG-, BJ-, BL-, and BM-types (Miniature Wire-Spring) Requirements and Adjusting Procedures.

**2. PRETEST PROCEDURES**

**2.01** Prior to performing the timing test, the portion of the frame on which the relay is mounted must be removed from service. This may be accomplished by means of the Maintenance Teletypewriter (TTY) in accordance with Section 231-130-301. When the frame has been made busy, remove the circuit pack containing the relay to be tested. If the relay is not in a system, it must be wired to return the operate and nonoperate pulses. Figure 3 illustrates this method.

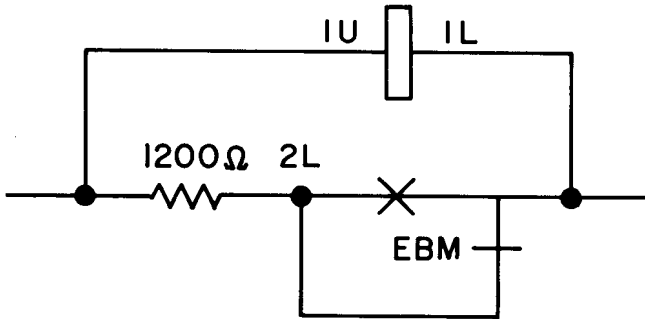

**Fig. 3—Winding, Resistor, and Contact Arrangement**

**3. METHOD OF CONNECTING THE J94735A TEST SET**

**3.01** The Timing Test Set is designed to operate from +25.5 +0.8 -1.20 and -51 ±1.75 volts

provided on central office frames. The W3BC cord (furnished with the test set) is used to connect the test set to the power source. Safety features are provided in the test set to prevent damage in case of an accidental wrong connection. The test set provides a means to check these voltages. For further information on the J94735A test set see CD-99348-01.

**3.02** The W3BD cord (furnished with the test set) is used to connect the relays to the J94735A test set.

**3.03** The operate time and release time are affected by armature back tension and balance spring adjustment. If it is found necessary to adjust a relay to meet timing requirements, the requirements for armature back tension must be rechecked. For this reason, it is necessary to follow the steps outlined in this section and shown schematically on the flow diagram (Fig. 4) to test and adjust these relays.

**4. RELAY TESTS**

**4.01 First Timing Test**

- (a) Connect the W3BD cord as follows:
  - (1) The GRD lead to terminal 1L of the relay under test.
  - (2) The UPPER lead to terminal 1U.
  - (3) Do not connect LOWER lead.
- (b) Set TEST switch to AL.
- (c) Set VOLT CHECK switch to NOR.
- (d) Set LATCH/CYCLE switch to CYCLE.
- (e) Rotate the TEST ADV switch in one-position steps.
- (f) Read time on the meter located on the control panel. The limits for each test are given in Table A.
- (g) Repeat Steps (e) and (f) until all four tests are completed.
- (h) Set LATCH/CYCLE switch to OFF.

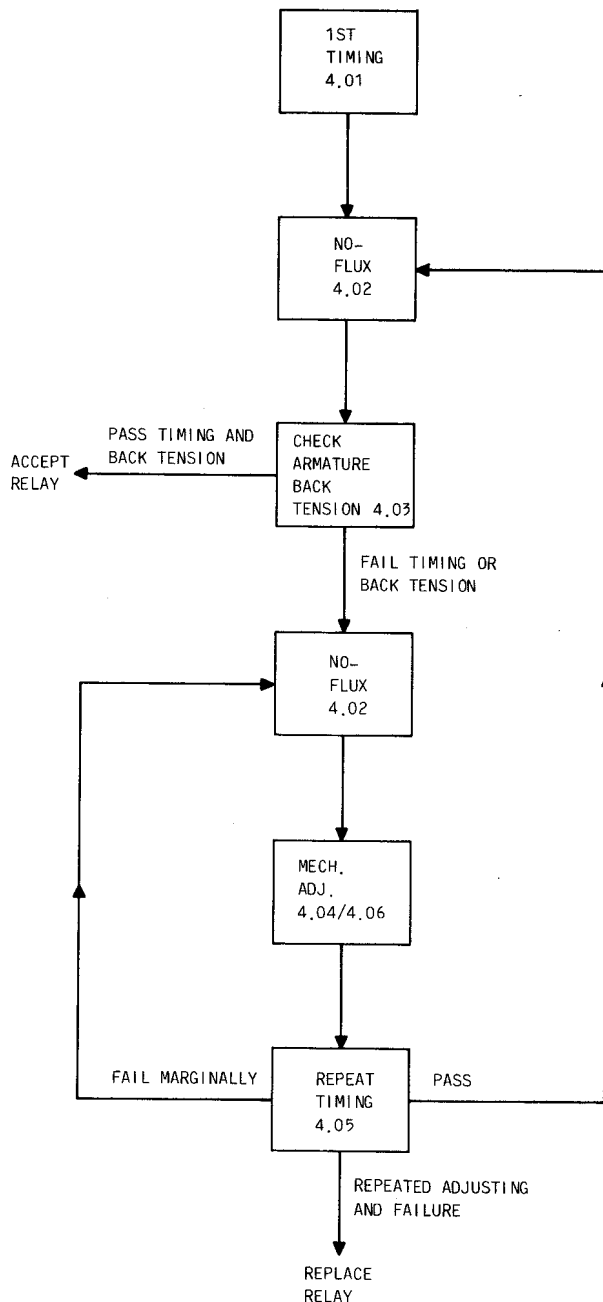

Fig. 4—Flow Diagram Relay Timing Test

**4.02 No-Fluxing the Relay:** Before any measurements or mechanical adjustments can be made in the armature back tension, the relay core must be placed in a no-flux condition. With the relay connected as in paragraph 4.01, proceed as follows:

- (a) Set TEST switch to AL.
- (b) Set VOLT CHECK switch to NOR.
- (c) Set LATCH/CYCLE switch to OFF.
- (d) Depress the AL/NO FLUX button momentarily but no longer than 5 seconds.

**4.03 Armature Back Tension Test:** After no-fluxing the relay, measure the armature back tension by applying the 70D gauge to the tip of the armature as described in Section 040-507-701. The armature shall bear against the armature backstop with a force of approximately 20 grams minimum.

If the relay passed the first timing test and the armature back tension is within limits, it is considered acceptable. No further tests are necessary.

**4.04 First Mechanical Adjustment:** This adjustment shall be performed if the relay fails either the first timing test or the armature back tension is out of requirements. To make it possible for the relay to meet these requirements the armature back tension is corrected using tools and methods described in Section 040-507-701. Generally, an increase in armature back tension will increase the operate time and decrease the release time, while a decrease in armature back tension will decrease the operate time and increase the release time.

**4.05 Repeat Timing Test:** This test is similar to the first timing test (paragraph 4.01). If the first test fails, readjust the armature back tension as described in paragraph 4.04. If the relay passes the second timing test recheck the back tension, after the relay is placed in a no-flux condition. If the relay passes the timing and tension tests, it may be rated acceptable; otherwise, proceed as follows.

**4.06 Repeat Mechanical Adjustment:** No-flux the relay as covered in paragraph 4.03.

**TABLE A**  
**TIMING LIMITS**  
**BL- AND BM-TYPE RELAYS**

CHECKS	TEST ADV SW POSITION	INDICATOR	TOLERANCE	
			TEST	READJUST
OPERATE	RIGHT	LAMP NO. 1	Max operate time 10.0 Milliseconds	Max operate time 9.5 Milliseconds
	LEFT	LAMP NO. 2	Min operate time 2.5 Milliseconds	Min operate time 3.0 Milliseconds
RELEASE	RIGHT	LAMP NO. 3	Max release time 10.5 Milliseconds	Max release time 10.0 Milliseconds
	LEFT	LAMP NO. 4	Min release time 2.5 Milliseconds	Min release time 3.0 Milliseconds

If the operate time is too long (greater than 10.0 msec), or the release time is too short (less than 2.5 msec), a decrease in back tension is necessary. In these cases, if the back tension is approximately 20 grams or less, no further adjustment in back tension is warranted and the relay should be replaced.

If the operate time is too short (less than 2.5 msec) or the release time is too long (greater than 10.5

msec), an increase in the back tension should be attempted so long as the mechanical adjustment of the balance spring can be done in accordance with Section 040-507-701. New bends or bows must not be added to the balance spring to increase back tension. If proper timing cannot be achieved within 3 or 4 attempts to increase balance spring tension, replace the relay.