

C TYPE RELAYS REQUIREMENTS AND ADJUSTING PROCEDURES

1. GENERAL

- 1.01 This section covers C type relays and replaces specification X-70078-01, Issue 1-D. accessible for other reasons or its performance indicates that such a check is advisable.
- 1.02 Reference shall be made to Section 020-010-711, covering General Requirements and Definitions for additional information necessary for the proper application of the requirements listed herein.
- 1.03 Part 1, "General" and Part 2, "Requirements" form part of the Western Electric Co. Inc. Installation Department handbook.
- 1.04 Requirements are marked with an asterisk (*) when to check for them would necessitate the dismantling or dismounting of apparatus, or would affect the adjustment involved or other adjustments. No check need be made for these requirements unless the apparatus or part is made
- 1.05 Operate means that when the operate current is applied, the armatures shall move sufficiently to break the back contact, to make the front contacts reliably and allow the right hand armature to touch its core.
- 1.06 Release means that when the current is reduced from the operate value to the release value (or open circuit), the armature shall move from the operated position sufficiently to break the contact, that has been made, and to make reliably the contact that has been broken. On relays having no back contact, the armature need not touch the back stop when the current is reduced to the release value.

2. REQUIREMENTS

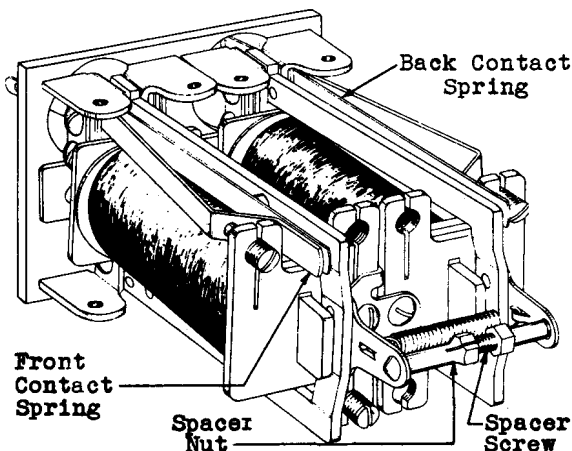

Fig. 1 - C2 and C3 Relays



Fig. 2

- 2.01 Cleaning The contacts and other parts shall be cleaned when necessary in accordance with the section covering cleaning of relay contacts and parts.
- 2.02 Relay Mounting Relays shall be mounted approximately level and fastened securely to the mounting plate. Gauge by feel.
- 2.03 Cover Cap The cover cap shall fit snugly but shall not be so tight as to prevent placing or removing with the fingers. Gauge by feel.
- 2.04 Contact Alignment Contacts shall line up so that the point of contact falls wholly within the circumference of the opposing contact disc. Gauge by eye.

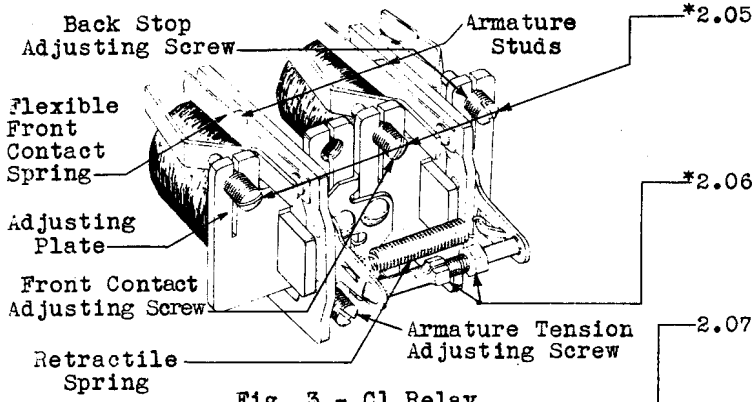

Fig. 3 - C1 Relay

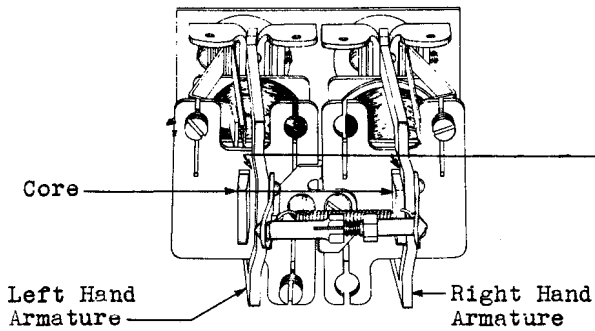

Fig. 4

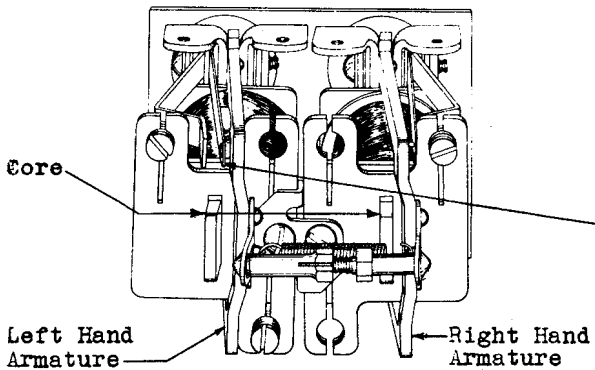

Fig. 5

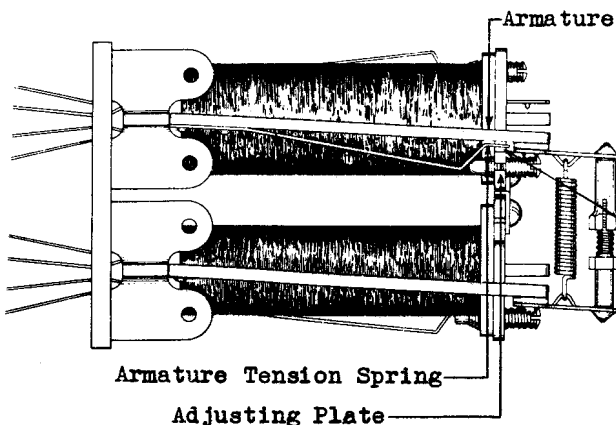

Fig. 6

***2.05** Tightness of Adjusting Screws The adjusting screws shall be sufficiently tight to prevent the relay changing its adjustment but shall not be so tight that it is necessary to use undue pressure in turning them. Gauge by feel.

***2.06** Tightness of Spacer Screw and Nut The slotted spacer nut shall be sufficiently tight on the spacer screw to hold the screw in any adjusted position. Gauge by feel.

2.07 Operated Position of Armatures

(a) Left-Hand Armature With the relay electrically operated the gap between the left-hand armature and its core, measured at the closest point, shall be:
Min. .005", Max. .010"
Use the No. 74-D gauge.

(b) Right-Hand Armature With the relay electrically operated the right-hand armature shall rest against its core. Gauge by eye.

2.08 Armature Travel

(a) C2 and C3 Relays With the relays unoperated the gap between the right-hand armature and its core shall be:
Max. .040"
Gauge by eye.

(b) C1 Relay No definite travel is specified for this relay.

2.09 Contact Separation The separation between contacts normally open or between contacts that are opened when the relay is operated shall be:

<u>C2 and C3 Relays</u>	Min. .010"
<u>C1 Relay</u>	Min. .020"

Use the No. 66-C gauge.

2.10 Contact Follow, that is, the distance the armature can move after the contacts have made shall be:

<u>C2 and C3 Relays</u>	Min. .005"
<u>C1 Relay</u>	Min. .010"

Gauge by eye.

2.11 Flexible Front Contact Spring Position The flexible front contact springs shall rest against the armature studs when the armatures are in the unoperated positions. Gauge by eye.

2.12 Electrical Requirements The relays shall meet the electrical requirements specified on the circuit requirements table.

2.13 Armature Tension Spring Position On relays equipped with the type of armature tension spring shown in Fig. 6, there shall be a perceptible clearance (approximately .005") between the armature and the spring and between the spring and the adjusting plate when the relay is in its operated or un-operated position. Gauge by eye.

ADJUSTING PROCEDURESTOOLS

<u>Code No.</u>	<u>Description</u>
35	Screw-driver - 3-1/2"
206	Screw-driver - 30° Offset
207	Screw-driver - 90° Offset
259	Spring Adjuster
388-A (2 re- quired)	Wrench - 3/16" and 1/4" Hex. Open Double End Offset
-	Bell System 3-1/2" Cabinet Screw-driver per A.T.&T. Co. Drawing 46-X-40
-	Bell System 4" Regular Screw-driver per A.T.&T. Co. Drawing 46-X-34
-	Bell System - P-Long Nose Pliers - 6-1/2" per A.T.&T. Co. Drawing 46-X-56

GAUGES

66-C	Thickness Gauge Nest
74-D	Thickness Gauge Nest

TEST APPARATUS

35	Test Set
----	----------

3.01 CLEANING (Rq.2.01)

M-1 Clean the contacts and other parts in accordance with the section covering cleaning of relay contacts and parts.

3.02 RELAY MOUNTING (Rq.2.02)

M-1 To align relays so that they are approximately level, loosen the mounting screws with the 3-1/2" cabinet screw-driver and shift the relay as required. Securely tighten the mounting screws.

M-2 To fasten relays securely to the mounting plate, tighten the mounting screws with the 3-1/2" cabinet screw-driver.

3.03 COVER CAP (Rq.2.03)

M-1 If the cover cap does not fit properly adjust the cover prongs as required using the long nose pliers.

3.04 CONTACT ALIGNMENT (Rq.2.04)

M-1 If the contacts are out of line from front to rear it will probably be necessary to replace the relay as there is practically no forward or backward movement of the springs.

M-2 If the contacts are out of line vertically, first attempt to move heavy springs by applying slight pressure to the free ends of the springs, exercising care not to damage them. If it is impossible to align the contacts in this manner adjust as follows:

M-3 Unsolder the leads and remove the relay from the mounting plate using the 3-1/2" cabinet screw-driver.

M-4 Remove the screws that hold the cover in place with the No. 35 screw-driver and take off the cover.

M-5 Loosen the spring assembly screws of the left-hand unit with the 3-1/2" cabinet screw-driver. To loosen the spring assembly screws of the right-hand unit, it will be necessary to remove the base plate screws with the 4" regular screw-driver and then remove the base plate. The assembly screws can then be loosened with the Nos. 206 and 207 offset screw-drivers. Shift the springs as required attempting to center the contacts as nearly perfect as possible and securely tighten the spring assembly screws. Replace the base plate, if removed.

M-6 Before replacing the cover and mounting the relay, note that the adjusting screws are in proper adjustment. Also note that the No. 2 spring of all relays and the No. 5 spring of the C1 relay (See Figs. 1 and 3) and the armature tension spring have a tension that will permit a satisfactory adjustment of the armature tension by means of the armature tension adjusting screw. This can usually be determined by noting how the relay functions when the electrical requirements are applied. The position of the armature tension spring should also be checked. If they are not met, adjust in accordance with procedures 3.05, 3.11 and 3.13.

M-7 Replace the relay cover and cover screws using the No. 35 screw-driver. Fasten the relays securely to the mounting plate using the 3-1/2" cabinet screw-driver, taking care that requirement 2.02 is met.

SECTION 040-508-701

3.05 TIGHTNESS OF ADJUSTING SCREWS (Rq.2.05)

- M-1 If the adjusting screws are too tight or too loose adjust as follows: Remove the relay from the mounting plate and remove the cover as outlined in procedure 3.04, M-3 and M-4.
- M-2 If the screws are too tight, widen the slot in the adjusting plate using the No. 35 screw-driver.
- M-3 If the screws are too loose, remove the ones at fault with the No. 35 screw-driver and then close up the slot in the adjusting plate using the long nose pliers.
- M-4 Care should be taken not to loosen the adjusting plate in making this adjustment.
- M-5 Before replacing the relay cover, note whether or not the conditions covered in procedure 3.04, M-6 are met and readjust for them if necessary.
- M-6 Replace the relay cover and cover screws using the No. 35 screw-driver. Fasten the relay securely to the mounting plate using the 3-1/2" cabinet screw-driver, taking care that requirement 2.02 is met.

3.06 TIGHTNESS OF SPACER SCREW AND NUT (Rq.2.06)

- M-1 If the slotted spacer nut is too loose on the spacer screw remove the spacer nut and screw from the relay by spreading the armatures apart slightly. Turn the spacer screw all the way out of the spacer nut.
- M-2 Close up the slot in the spacer nut using the long nose pliers. Do not get the screw and nut to fit so tight that the screw cannot be turned easily with the No. 388-A wrench.
- M-3 If the screw and nut fit too tight, widen the slot in the nut slightly using the No. 35 screw-driver, after removing the nut and screw from the armature arms.

3.07 OPERATED POSITION OF ARMATURES (Rq.2.07)
3.08 ARMATURE TRAVEL (Rq.2.08)

- M-1 If the gap, between the left-hand armature and the core in the operated position is not within the specified limits, turn the spacer screw with the No. 388-A wrench holding the spacer nut with another No. 388-A wrench as shown in Fig. 7. To increase or decrease the operated air-gap, move the wrench up or down respectively,

as required. This adjustment also establishes to a certain extent the armature travel for the right-hand armature.

- M-2 If the travel is excessive turn screw "B" (See Fig. 7) in a clockwise direction with the No. 35 screw-driver. Note whether or not the contact separation requirement is still met. If the right-hand armature does not touch its core, readjust the contact follow or the back pressure in accordance with procedures 3.10 and 3.13.

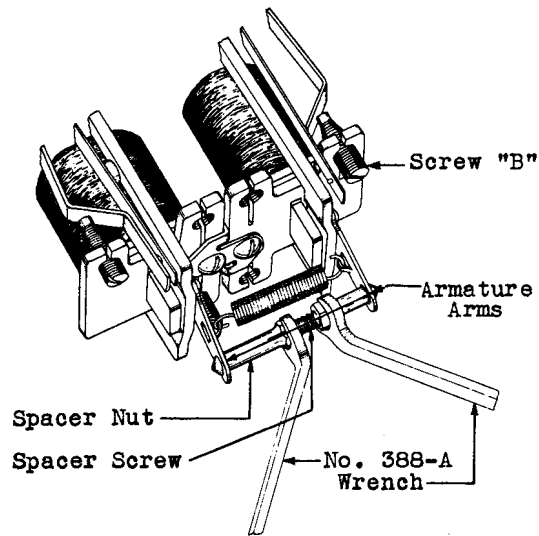

Fig. 7 - Method of Adjusting for the Operated Position of Armatures

3.09 CONTACT SEPARATION (Rq.2.09)
3.10 CONTACT FOLLOW (Rq.2.10)

- M-1 Front Contacts If the contact separation and follow requirements are not met, adjust the front contact adjusting screw (or screws) with the No. 35 screw-driver. Turning the screws in a clockwise direction decreases the contact separation and increases the follow and turning the screw in a counter-clockwise direction increases the contact separation and decreases the follow. Adjust the screw until the separation is at or near the minimum. This will insure a contact follow that is well above the minimum. See Fig. 8.

3.09-3.10 (Continued)

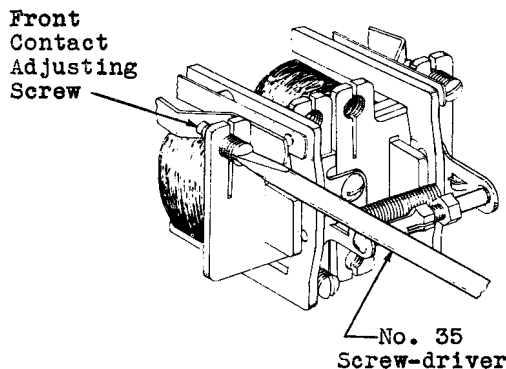

Fig. 8 - Method of Adjusting
For Contact Separation

M-2 Back Contacts If the contact separation requirement is not met on the contacts that are opened when the relay is operated adjust the back contact adjusting screw with the No. 35 screw-driver. Turning the screw in a clockwise direction decreases the back contact separation and turning the screw in a counter-clockwise direction increases the back contact separation. As this screw also controls the armature travel for the right-hand armature, the armature travel should be checked.

3.11 FLEXIBLE FRONT CONTACT SPRING POSITION (Rq.2.11)

- M-1 If the flexible front contact springs do not rest against the armature studs when the armatures are in the unoperated position adjust as follows:
- M-2 Remove the relay from the mounting plate and remove the cover as outlined under procedure 3.04, M-3 and M-4.
- M-3 Adjust the spring with the No. 259 spring adjuster applying it to the spring at its back end and giving it a twist towards the armature.
- M-4 Before replacing the relay cover, note whether or not the conditions covered in M-6 under procedure 3.04 are met and readjust for them if necessary.
- M-5 Replace the relay cover and cover screws using the No. 35 screw-driver. Fasten the relay secure-

ly to the mounting plate using the 3-1/2" cabinet screw-driver.

3.12 ELECTRICAL REQUIREMENTS (Rq.2.12)

3.13 ARMATURE TENSION SPRING POSITION (Rq.2.13)

M-1 Operate If the relay fails to operate satisfactorily the backward tension of the armature is probably too much and it should be reduced. To do this turn the armature tension screw in a clockwise direction with the No. 35 screw-driver, consistent with meeting its release requirement. This increases the tension of the armature tension spring and opposes the backward tension exerted on the armature by the flexible front contact springs.

M-2 Release If the relay fails to release properly, the backward tension of the armature is probably insufficient and should be increased. To do this turn the armature tension screw in a counter-clockwise direction with the No. 35 screw-driver consistent with meeting the operate requirement. This decreased the tension of the armature tension spring which opposes the backward tension exerted on the armature by the flexible front contact spring.

M-3 If difficulty is experienced in meeting the operate and release requirements it may be due to the tension of the flexible front contact springs which should be adjusted as required and as outlined in procedure 3.11.

M-4 Difficulty in making the adjustment of the relay is sometimes due to the armature tension spring having slipped from its normal position. This condition will be evident if in turning the armature tension screw forward it does not affect the tension of the armature. In such cases the tension spring may be recovered to its normal position by means of a small improvised hook which can be made from a gem clip or a piece of wire. Turn the armature tension screw in a counter-clockwise direction until it clears the spring, slip the hook in so as to catch the spring, move the spring towards the armature and then turn the screw in a clockwise direction.

M-5 If difficulty is experienced in making the adjustment of the relay it may be that one of the armature hinge plates is broken. This can usually be determined by holding the armatures with the thumb and forefinger and checking to see that they are supported by both the upper and lower hinge plates.

M-6 Armature Tension Spring Position
In those cases where the armature

3.12-3.13 (Continued)

tension spring is of such a design that the tip of it extends forward between the armature and the adjusting plate note that it is in its specified position.

M-7 If it is not in the specified position remove the relay from the mounting plate, remove the cover and reduce or increase the tension of the tension spring as required with the No. 259 spring adjuster applying it at the rear of the spring.

M-8 Replace the relay and repeat the

adjustments to meet the electrical requirements.

M-9 Final Check In all cases after a relay has been adjusted the springs controlled by the adjusting screws should be lifted slightly away from the screw and allowed to return to the normal position which they will assume in service. Then replace the cover cap and check to insure that the relay meets its electrical requirements. This check can generally be made by observing the operation of associated apparatus in the circuit.