

Y AND 282-TYPE RELAYS

PIECE-PART DATA AND REPLACEMENT PROCEDURES

1. GENERAL

1.01 This section covers the information necessary for ordering parts to be used in the maintenance of Y- and 282-type relays. It also covers approved procedures for replacing these parts.

1.02 This section is reissued to revise Fig. 3 and to revise the List of Tools and Gauges.

1.03 Part 2 of this section covers the piece-part numbers and the corresponding names of the parts which it is practicable to replace in the field in the maintenance of the relays. No attempt should be made to replace parts not designated. Part 2 also contains explanatory figures showing these different parts. This information is called Piece-part Data.

1.04 Part 3 of this section covers the approved procedures for the replacement of the parts covered in Part 2. This information is called Replacement Procedures.

1.05 Before making any replacement on the apparatus covered herein, remove the circuit from service.

2. PICEC-PART DATA

2.01 The figures included in this part show the various piece parts in their proper relation to other parts of the relay. The piece-part numbers of the various parts are given together with the names of the parts as listed by the Western Electric Company Merchandise Department. When these names differ from those in general use in the field, the latter names, in some cases, are shown in parentheses.

2.02 When ordering parts for replacement purposes, give both the piece-part number and the name of the piece-part, for example, P-466091 Nut. Do not refer to the BSP number or to any information shown in parentheses following the piece-part number.

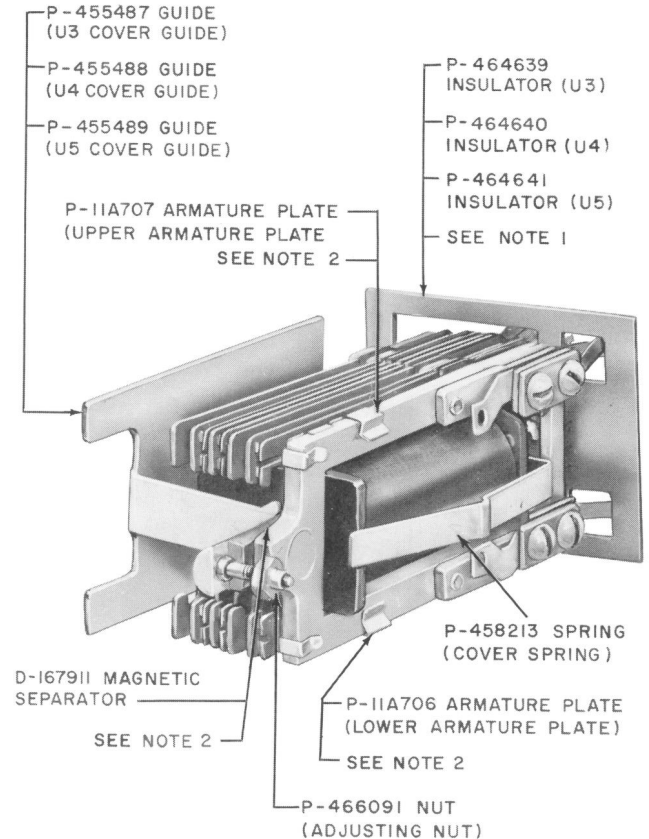

NOTES:
1. USED WITH COVER GUIDE STAMPED AS DESIGNATED.
2. USED ON Y-TYPE RELAYS ONLY.

ES-908794-1

Fig. 1—Y-Type Relay—General View

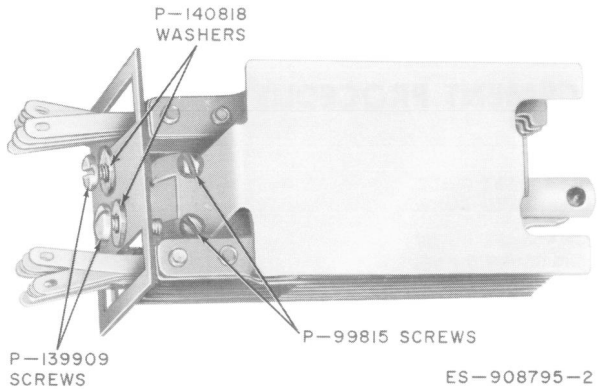

Fig. 2—Y-Type Relay—Side View

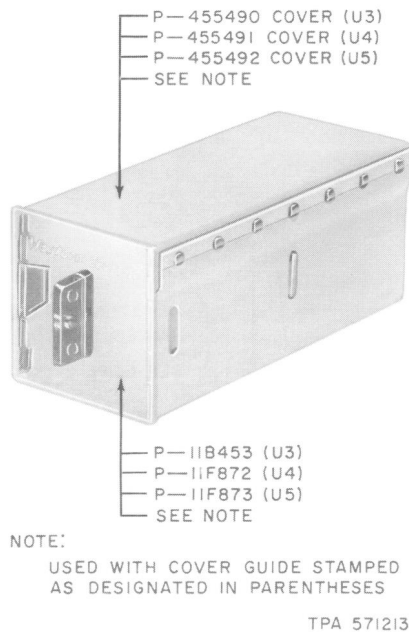

Fig. 3—Cover and Cover Cap (U4 Illustrated)

3. REPLACEMENT PROCEDURES

3.01 List of Tools and Gauges

CODE OR SPEC NO.	DESCRIPTION
TOOLS	
474A	3/16-inch by 1/4-inch Closed Double-end Offset Wrench
485A	Smooth Jaw Pliers
KS-6320	Orange Stick
D-167912	Magnetic Separator Adjuster
◆—	3-inch C Screwdriver (or the replaced 3-inch cabinet screwdriver)
◆—	4-inch E Screwdriver (or the replaced 4-inch regular screwdriver)
◆AT-7860	B Long-nose Pliers
GAUGE	
131A	Thickness Gauge Nest

3.02 No replacement procedures are specified for screws or other parts where the replacement consists of a simple operation.

3.03 After making any replacement of parts of a Y- or 282-type relay, the part or parts replaced shall meet the readjust requirements involved as specified in Section 040-522-701 covering the Y-type relay and Section 040-260-701 covering the 282-type relay. Other parts whose adjustments may have been directly disturbed by the replacing operations shall be checked to the readjust requirements and an over-all operation check shall be made of the relay before restoring the circuit to service.

3.04 Cover Spring, Cover Guide, and Insulator:

To replace a cover spring, cover guide, or insulator, remove the relay from the mounting plate as follows. Unsolder and tag the leads. Remove the mounting screws with the 4-inch E screwdriver and remove the relay. If the insulator is to be replaced, remove it and substitute the new insulator. If the cover spring or cover guide is to be replaced remove the associated mounting screws using the 3-inch C screwdriver. Remove the spring or guide as required and substitute the new parts. Position the mounting end of the cover spring under the winding terminals at the rear of the relay core, and while holding the spring in place, mount the cover guide over the core at

the opposite side of the relay. Insert and securely tighten the associated mounting screws. Check that the cover spring clears the winding terminals. Remount the relay securely on the mounting plate. Connect and solder the leads to the proper terminals.

3.05 Adjusting Nut: To replace the adjusting nut, remove the nut with the 474A wrench. Substitute the new adjusting nut and tighten it to meet the requirement covered in Section 040-522-701 covering the Y-type relay and Section 040-260-701 covering the 282-type relay.

3.06 Magnetic Separator

(1) To remove the magnetic separator from the core, insert the 3-inch C screwdriver between the convolutions of the separator and the core and pry the convolutions open. Remove the separator with the fingers.

(2) To place a magnetic separator on the core, insert the long end in the armature gap from the top and pass it down between the core and the armature until the bend of the separator rests approximately on the top edge of the core pole face as shown in Fig. 4. With the front edge of the separator close to the adjusting stud, insert the 0.020-inch blade of the 131A gauge into the armature gap as shown in Fig. 5, and electrically energize the relay. While holding the relay manually operated, disconnect the current from the relay, and with the gauge in place, pull the separator downward with the 485A pliers until the bend of the separator fits snugly against the upper edge of the core pole face. Hold the separator in this position and electrically energize the relay so the gauge presses the separator firmly against the core pole face. With the KS-6320 orange stick bend the lower end of the separator around the lower end of the core so it clears the relay springs. Grasp the lower end of the separator with the 485A pliers and pull it toward the left in line with the lower edge of the core, at the same time rubbing the separator with the orange stick to shape it around the lower edge of the core. Release the relay and slide the separator to the rear of the core pole face.

(3) Electrically energize the relay against the 131A gauge inserted in the armature gap. Shape the separator around the core with the orange stick and fingers so the two narrow bands

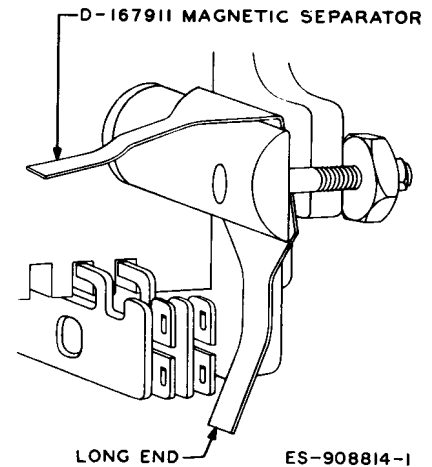

Fig. 4—Method of Inserting D-167911 Magnetic Separator in Armature Gap

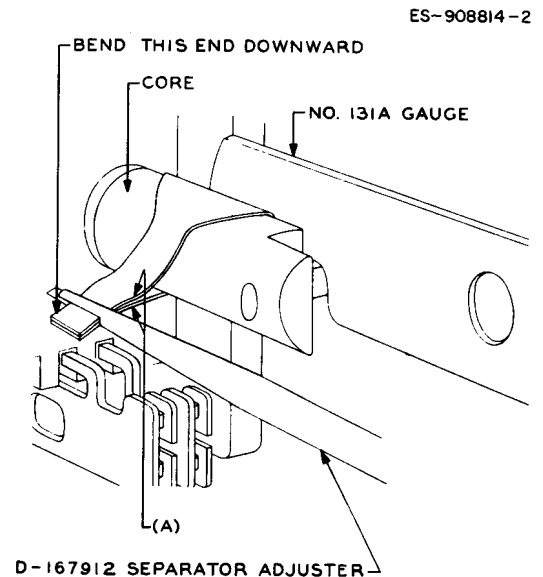

Fig. 5—Method of Using D-167912 Separator Adjuster

come nearly together at (A) Fig. 5. Place the flat surface of the long point of the D-167912 magnetic separator adjuster against the underside of the bottom band of the separator and press upward with the adjuster, at the time pressing down on the upper band of the separator with a forefinger. When the two bands contact, push the adjuster forward so the two bands slide into the slot. Move the adjuster to the left until the length of the separator extending to the left of the adjuster is only slightly greater than the

width of the adjuster as shown in Fig. 5. Hold the adjuster so both ends of the separator coincide and bend the tips of the separator which project through the adjuster downward with a finger or orange stick. Then holding the adjuster horizontally in line with the core, move the handle of the adjuster slightly to the left so the side of the tapered end of the adjuster nearest the core is parallel to it. Then twist the adjuster in a clockwise direction until the ends of the separator are firmly wound together concentrically and the separator fits snugly all around the core as shown in Fig. 6. With the relay still energized, lift the gauge off the stud and with a rotary motion move it up and down between the armature and the separator two or three times to flatten out the entire surface of the separator against the pole face. Again rotate the adjuster to ensure that the separator is tight. Then hold the separator in place with a finger tip and withdraw the adjuster. Flatten the convolutions of the separator with the 485A pliers as shown at (A) Fig. 7; then fold the flattened convolutions in a clockwise direction with a finger or the orange stick against the rear of the core as shown at (B) Fig. 7. Again rotate the 131A gauge. Release the relay and remove the gauge.

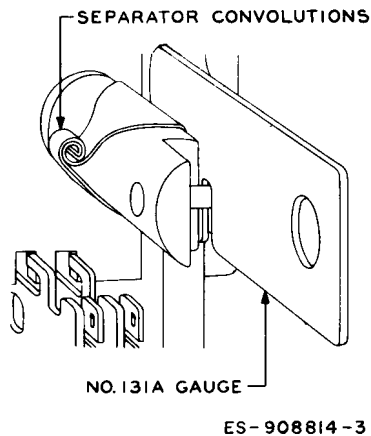

Fig. 6—D-167911 Separator Convolution After Removal of D-167912 Separator Adjuster

(4) After mounting the separator, check the relay for armature travel, stud gap, contact

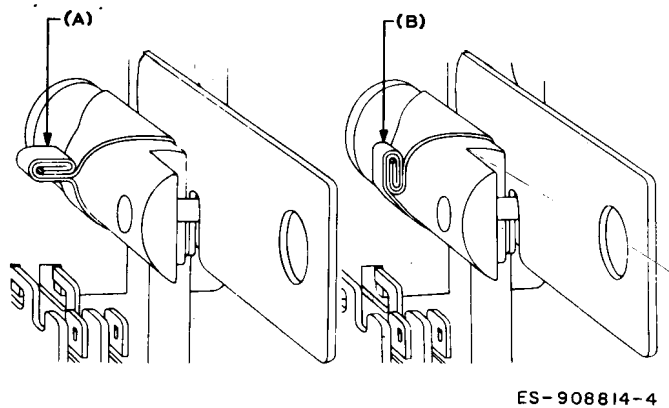

Fig. 7—Flattening of Separator Convolution

make, contact separation, and electrical requirements as covered in Section 040-522-701.

Note: If difficulty is experienced in meeting the electrical requirements, it may be due to a damaged or incorrectly applied separator.

3.07 Armature Plate

(1) To remove an armature plate proceed as follows. Using the KS-6320 orange stick, push the front clip of the armature plate so the vertical portion of the plate projects slightly beyond the armature. Grasp this portion of the plate with the 485B long-nose pliers and pull the plate forward off the armature. Mount a new armature plate as covered in (2) and (3).

(2) Insert the KS-6320 orange stick between the armature leg and the adjacent spring until the tip of the orange stick rests against the spring stud. Move the spring away from the armature to provide stud clearance for mounting the armature plate. Holding the armature plate with the disc toward the relay springs, place the rear clip of the plate over the leg of the armature. Slide the plate toward the rear of the relay until the front clip fits snugly against the front edge of the armature leg. Withdraw the orange stick and check that the end of the spring stud rests against the armature plate within the circumference of the disc on the plate. Also check that the positioning

(
(
tab and rear clip of the plate rest against the inner edge of the armature leg as shown in Fig. 1. If necessary, properly position the plate on the armature leg with the orange stick.

(3) After mounting the armature plate, check the relay to all requirements covering the springs and also to the electrical requirements covered in Section 040-522-701.