

D-85083 RELAYS REQUIREMENTS AND ADJUSTING PROCEDURES

1. GENERAL

1.01 This section covers D-85083 relays. It is reissued to incorporate material from the addendum in its proper location. In this process marginal arrows have been omitted.

1.02 Reference shall be made to Section 020-010-711 covering General Requirements and Definitions for additional information necessary for the proper application of the requirements listed herein.

1.03 Part 1, "GENERAL" and Part 2, "REQUIREMENTS" form part of the Western Electric Co. Inc., Installation Department handbook.

1.04 Requirements are marked with an asterisk (*) when to check for them would necessitate the dismantling or dismantling of apparatus, or would affect the adjustment involved or other adjustments. No check need be made for these requirements unless the apparatus or part is made accessible for other reasons or its performance indicates that such a check is advisable.

1.05 Ordinarily this relay should be returned to the shop for adjustment. Where conditions do not permit this, it may be possible to obtain satisfactory operation of the relay by following the procedures covered here.

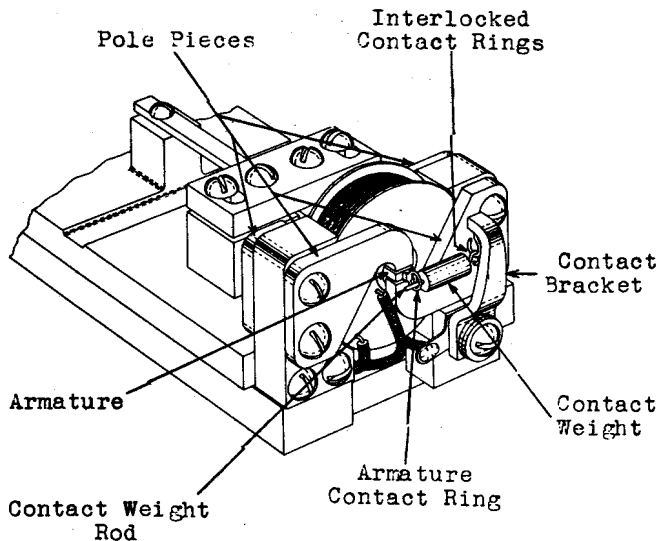

Figure 1

2. REQUIREMENTS

2.01 Cleaning

(a) Fig. 1 - The contacts between the contact weight and the contact rings shall be cleaned when necessary.

(b) The four air gaps shall be free from any small particles clinging either to the armature or to the pole faces.

2.02 Relay Mounting Fig. 2 - The relay shall be held securely by its associated mounting plate and connecting block. Gauge by feel.

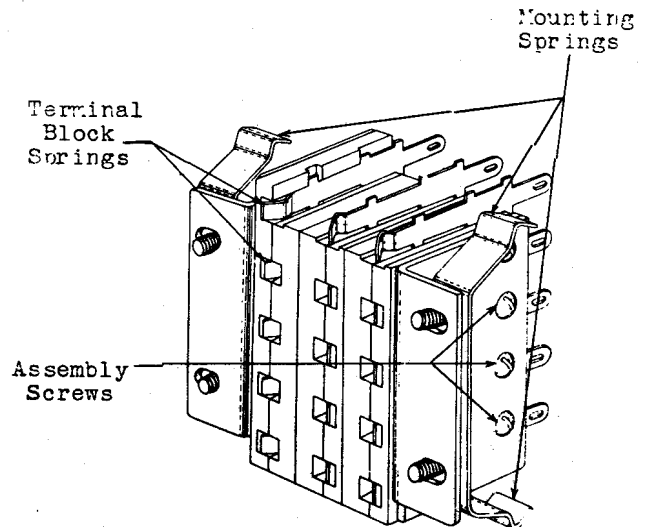

Figure 2

*2.03 Relay Terminals and Nuts Fig. 3 - The relay terminals shall be straight and shall be held tightly with the lock nuts. Gauge by eye and by feel.

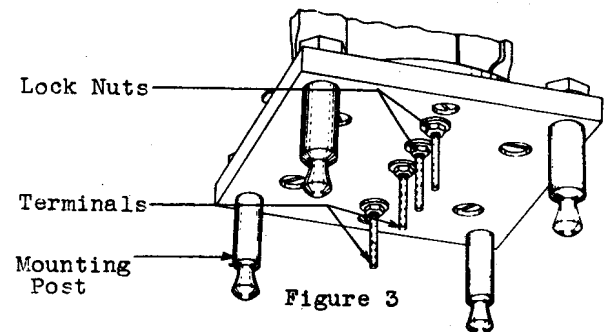

Figure 3

SECTION 040-603-701

2.04 Air Gap Fig. 4 - The air gap between the pole pieces and the armature shall be

Min. - The armature shall not stick to the upper or lower pole pieces when pushed against them by hand.

Max. - .013".

Use the No. 92-B gauge.

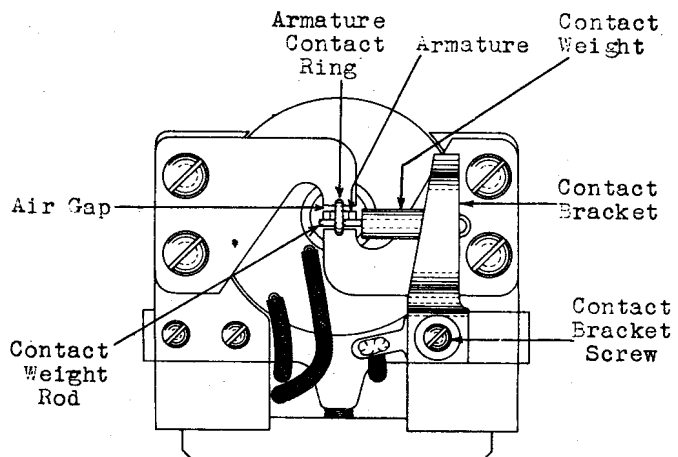

Figure 4

3. ADJUSTING PROCEDURES**3.001 List of Tools, Gauges and Materials**

<u>Code No.</u>	<u>Description</u>
<u>Tools</u>	
46	Wrench 3/8" Hex. Socket
147	Screw-driver 3-1/8"
206	Screw-driver offset
-	No. 4 Artists Sable Rigger Brush
-	Long Nose Pliers
403-A	Wrench 5/32" & 3/16" Hex. Socket Double-End
<u>Gauges</u>	
92-B	.013" Thickness Gauge Non-Magnetic
<u>Materials</u>	
KS-7860	Petroleum Spirits
KS-2423	Cleaning Cloth
-	Toothpicks, Hardwood Flat at One End and Pointed at the Other

3.01 Cleaning (Rq.2.01)

(1) To make the contact surfaces accessible for cleaning, the contact bracket should be removed. This may be done by loosening the screw which holds the bracket in place. The contact weight will come away with the bracket because its ring is interlocked with the bracket ring.

(2) Clean the contacting surface of the armature contact ring with petroleum spirits applied with the No. 4 artists sable rigger brush. In the same manner clean the contacting surfaces of the two interlocked contact rings and also the straight contact rod of the contact weight. After cleaning, the contacting surfaces should be burnished to remove traces of any deposit remaining after the petroleum spirits has evaporated. This may be done with a small piece of KS-2423 cloth using a toothpick to press the cloth against the contacting surfaces. Replace the bracket, carefully placing the contact weight in position before tightening the contact bracket screw.

NOTE: Check that the contact weight can not fall out of place after the screw is tightened.

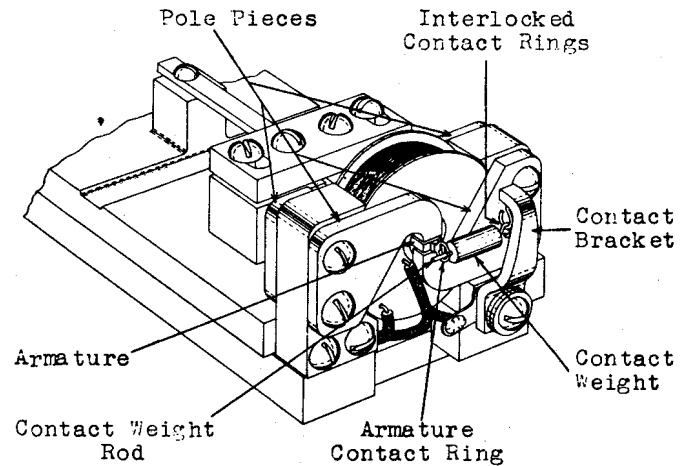

Figure 5

(3) If the air gaps have any small particles clinging to the pole-pieces or to the armature remove them with a clean No. 4 artists sable rigger brush or with a piece of KS-2423 cloth.

3.02 Relay Mounting (Rq.2.02)

(1) If a relay is not held securely by the associated mounting plate and connecting block, remove the relay from the mounting and determine whether the mounting posts or terminal blocks are loose.

(2) If a mounting post is loose, tighten the nut holding it to the relay terminal block using the No. 46 wrench.

(3) If the relay terminal block is loose tighten the screws holding it to the relay base using the 147 screw-driver.

(4) If neither the mounting posts nor the screws holding the relay terminal block to the relay base are loose tension the mounting springs of the connecting block as required using the long nose pliers.

(5) Observe that the relay terminals make good contact with the connecting block springs and if they do not, correct as follows: Remove the connecting block from its mounting by removing the connecting block mounting screws and then remove the screws which hold the block

assembled, using the 147 screw-driver. With the block unassembled, adjust the tip of the particular spring or springs at fault as required with the long nose pliers and then reassemble the block and fasten it securely to its mounting.

3.03 Relay Terminals and Nuts (Rq.2.03)

(1) When necessary, straighten relay terminals with the long nose pliers and tighten loose lock nuts with the No. 403-A wrench. In tightening the nuts, exercise care not to twist the connecting wires from the terminals.

3.04 Air Gap (Rq.2.04)

(1) If the armature is "frozen" to either the upper or lower pole-pieces this is due to the air gap being too small. Increase the air gap slightly by shifting the position of the pole-piece to which the armature is "frozen" as described in the following paragraph.

(2) To increase or decrease the air gaps between the armature and the pole pieces, loosen slightly the pole piece screws with the 147 screw-driver or the 206 offset screw-driver and shift the pole piece as required. Tighten the pole piece screws securely after the adjustment is completed.

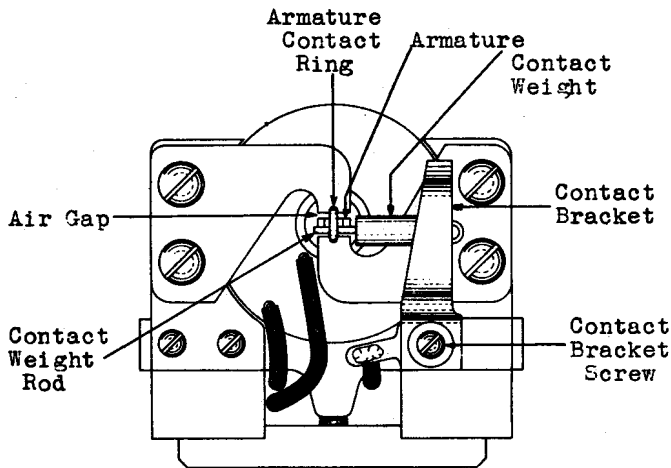

Figure 6