

RELAYS AND RELAY SETS

SIGNAL TYPE

REQUIREMENTS AND ADJUSTING PROCEDURES

1. GENERAL

- 1.01 This section covers Signal Engineering and Manufacturing Company type KS-3067, KS-5013, KS-5483, KS-5635, KS-6319, KS-6724, and KS-15601 relays as well as the relays in KS-5381 and KS-8854 relay sets.
- 1.02 This section is reissued to incorporate material from the addendum in its proper location. In this process marginal arrows have been omitted.
- 1.03 Reference shall be made to Section 020-010-711 covering General Requirements and Definitions for additional information necessary for the proper application of the requirements listed herein.
- 1.04 Whether contacts are normally open (NO) or normally closed (NC) depends on the position of these contacts when no operating current is flowing in the coil and not on the position the contact may normally be in for a particular application. NO contacts and NC contacts are sometimes known as front and back contacts, respectively. A double throw relay is one that has an NO and NC contact on the same pole.
- 1.05 A relay or switch is said to release when the armature has moved sufficiently for normally open contacts to open and normally closed contacts to close with reliable contact.
- 1.06 A relay or switch is said to operate when the armature has moved sufficiently for normally closed contacts to open and normally open contacts to close with reliable contact.
- 1.07 A relay or switch, except a relay with normally closed contacts whose coil is rated in amperes alternating current, is said to be nonoperated when at the specified value the armature has not moved sufficiently for

normally open contacts to close or for reliable contact on normally closed contacts to be interrupted. A relay with normally closed contacts, and whose coil is rated in amperes alternating current, is said to be nonoperated when at the specified current the contact pressure is not less than the minimum specified in 2.05 and Table A.

- 1.08 When work is done on a relay in an operating circuit, see that service is maintained. Do not touch at the same time live terminals or parts which are at different potentials or otherwise short-circuit them.
- 1.09 Relays must not be handled by the contact springs.
- 1.10 Checks and adjustments shall be made with the relay mounted in a vertical position (see Fig. 1).

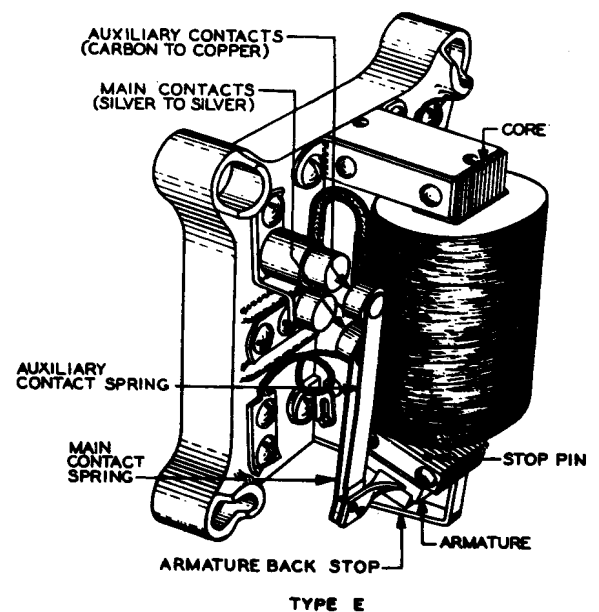

Fig. 1 - KS-3067 Relay

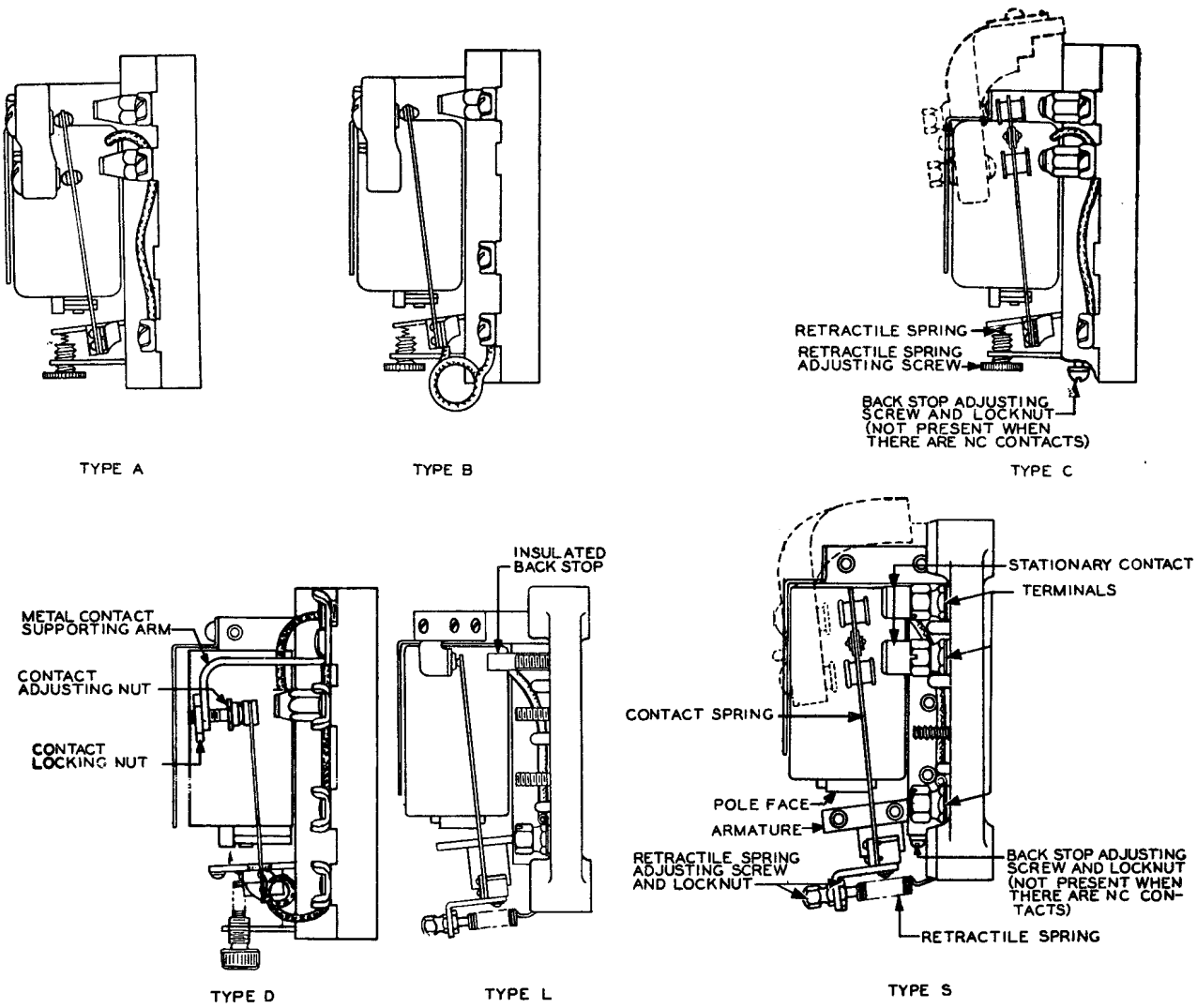

Fig. 2 - KS-5483 Relay

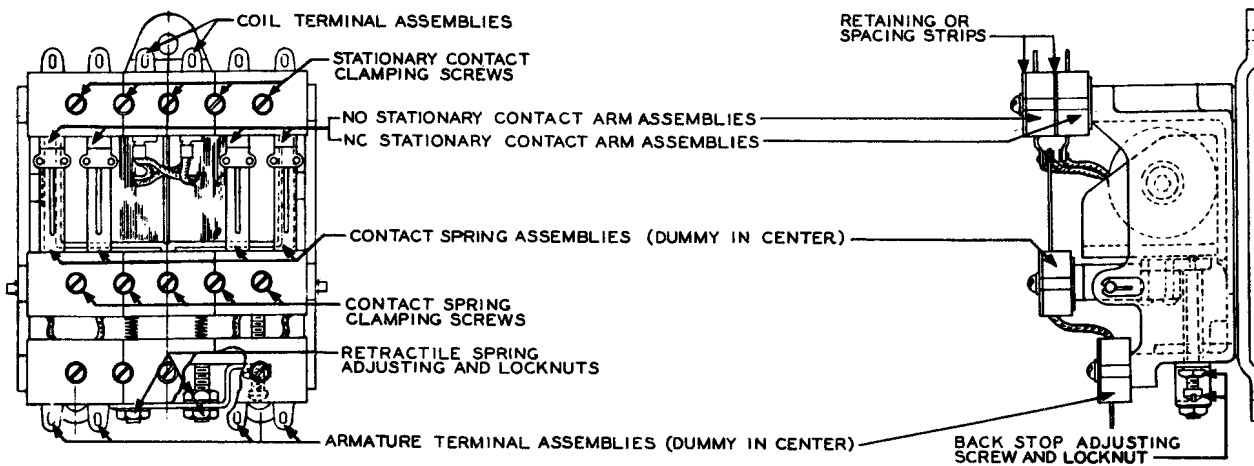

Fig. 3 - KS-5635 Relay (Operated)

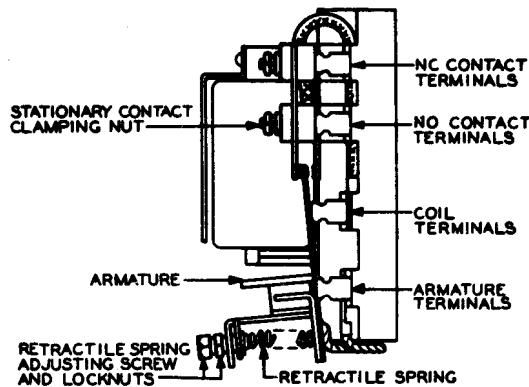

Fig. 4 - KS-15601 Relay

2. REQUIREMENTS

- 2.01 Tightness of Assembly** (Gauge by feel)
- Spring assemblies shall be fastened securely to the armature.
 - Armature backstops of the type shown in Fig. 1 shall be fastened securely to the brass yoke at the base of the core.
- 2.02 Contact surfaces** shall be clean and free from burrs.
- 2.03 Contact Alignment** (Gauge by eye)
- Each set of contacts shall be aligned so that when contacts are completely closed the outer edge of one contact does not overlap the outer edge of the other contact by more than the following maximum values:
- | Relay Type
(See Table B) | Inch
Maximum |
|--------------------------------------|-----------------|
| E,S,SC,SS | 1/16 |
| A,B,C,D,L,R,KS-5635,KS-8854,KS-15601 | 1/32 |
- If the contacts are of different sizes, the smaller shall not extend beyond the periphery of the larger.
- Where both contact surfaces are flat, they shall rest flat against each other when contacts are completely closed.
- 2.04 Contact Sequence** (Gauge by eye)
- On relays except E type
 - All normally open contacts shall make and break simultaneously.
 - All normally closed contacts shall break and make simultaneously.
 - On relays with auxiliary contacts, such as the E type (see Fig. 1)
 - Auxiliary contacts shall make before the main contacts make and break after the main contacts break.
 - Both main contacts shall make and break simultaneously.

- Both auxiliary contacts shall make and break simultaneously.

2.05 Contact Pressure: Minimum contact pressure for each type of relay shall be as listed in Table A, below. Normal contact pressures listed are for information only. The type of each relay is shown in Table B and is usually given on the relay nameplate. The effect that other contact springs on the same armature have on contact pressure has been considered and can be ignored. The contact pressures for C, S, SC, and SS relays should be measured on each contact at the edge of the contact button farthest away from the contact pivot point and on the opposite side of the contact spring from the contact whose pressure is being measured. Contact pressure values for KS-5635 relays are for both contacts of a split spring taken together and shall be measured on the split spring just below the two contacts. Contact pressure values for KS-15601 relays are for each individual contact of a split spring and shall be measured on the spring just below the contact. Contact pressures on other relays shall be measured on the contact spring just below the contact. Use push-pull tension or fan-type gram gauge.

2.06 Contact Gap: Minimum contact gap for each type of relay shall be as listed in Table A. Use thickness gauge or scale. Where contact gaps on one side of contact spring meet requirements and it is difficult to apply gauge to the contacts on the other side of the spring, the clearance on these contacts may be assumed to be satisfactory. The contact gap should be measured by inserting the thickness gauge between the movable and stationary contacts. On B, D, E, L, KS-5635, KS-8854, and KS-15601 relays, the gauge shall pass between the contacts. On A, C, S, SC, and SS relays, the gauge shall be placed as shown in Fig. 5 and shall extend across at least 3/4 of the diameter of the stationary contact nearer the armature hinge before touching the movable contact.

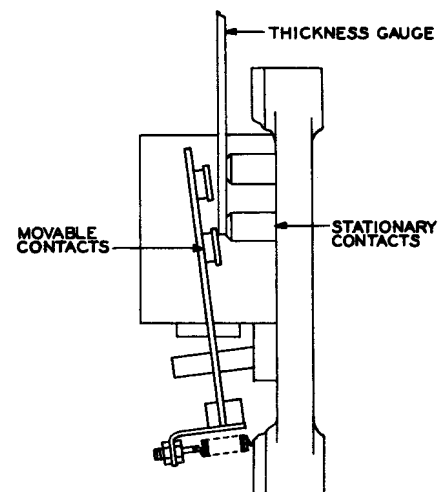

Fig. 5 - Method of Measuring Contact Gap

TABLE A - CONTACT PRESSURES AND GAPS

Type of Relay	Contact Pressure in Grams				Contact Gap Inch Minimum
	Minimum		Normal		
	NO	NC	NO	NC	
A7	10	-	12	-	0.092
A8	-	10	-	12	0.060
A9	10	10	12	12	0.060
A19	10	10	12	12	0.060
A49	10	10	12	12	0.060
B	10	10	12	12	0.092
C	18	10	35	15	0.092
D dc	30	30	-	-	0.092
D ac	25	25	-	-	0.092
E(main)	80	-	-	-	0.092
E(aux)	50	-	-	-	0.092
L	15	6	20	7	1/8 (0.125)
R	60	15	70	20	1/8
†S7	25	25	50	35	0.092
S9	25	25	50	35	0.092
KS-5483, L02 (S7)	25	25	50	35	0.074
SS	25	-	50	-	3/16
SC	25	-	50	-	3/16
KS-5635, L01 to L03	60	60	-	-	0.092
KS-5635, L04	60	-	-	-	3/16
KS-8854	50	-	-	-	0.092
KS-15601	30*	30*	-	-	0.033

*Each contact
†Except KS-5483, L02

2.07 Relay Mounting: The relay shall be fastened securely to its mounting. Gauge by feel.

2.08 Electrical Requirements:

- (a) The relay shall meet the electrical requirements specified on the Circuit Requirements Table.
- (b) Check of electrical requirements may be made at the temperature at which the relay is found by the attendant, unless "H" (hot) or "C" (cold) is specified in the Circuit Requirements Table.
- (c) Where "H" is specified in the Circuit Requirements Table without heating instructions, the relay coils shall be energized for at least one hour prior to the test.
- (d) Where "C" is specified in the Circuit Requirements Table without cooling instructions, the relay shall be de-energized for at least two hours prior to the test.
- (e) Unless otherwise specified, the electrical requirements given in the Circuit Requirements Table for KS-5635, List 01 relays apply to each coil separately energized.
- (f) Where electrical requirements are not specified in the Circuit Requirements Table, operation of the relay shall be checked in accordance with Table B, below.

For use only when values are not shown in Circuit Requirements Table.

TABLE B - ELECTRICAL REQUIREMENTS AND RELAY TYPES

Relay	Type	Values in AC Volts at 60 Cycles or DC Volts	Min Operate	Nonoperate	Release
KS-3067	E	Volts DC	16		
KS-5013 L1	E	Volts DC	20		
KS-5013 L2	E	Volts DC	20		
KS-5013 L3	E	Volts DC	36		
KS-5381 L1	L5	AC Volts	94		
KS-5381 L2	L5	AC Volts	200		140
KS-5381 L3	R1	Volts DC	14		
KS-5381 L4	R1	Volts DC	14		
KS-5381 L5	C7	(AC Volts (Volts DC	100		
KS-5381 L6 (Old)	B4			130 (note 6)	
KS-5381 L6 (New)	A7	AC Volts	18		
KS-5381 L7	R1	Volts DC	16		
KS-5381 L8 (L)	A9	Volts DC	42		
KS-5381 L8 (R)	A49	AC Volts	207		
KS-5381 L9 (L)	S7	Volts DC	42		
KS-5381 L9 (R)	S7	Volts DC	42		
KS-5381 L10 (L)	L2	AC Amps	20		
KS-5381 L10 (R)	S7	Volts DC	42		
KS-5381 L11	C8	Volts DC	20		
KS-5381 L12 (L)	A9	Volts DC	42		
KS-5381 L12 (R)	A49	AC Volts	207		
KS-5381 L13	C7	Volts DC	20		
KS-5381 L14 (L)	L2	AC Amps	17		
KS-5381 L14 (R)	S7	Volts DC	42		
KS-5381 L15	C7	(AC Volts (Volts DC	100		
				130 (note 6)	

Relay	Type	Values in	Min	Nonoperate	Release
		AC Volts at 60 Cycles or DC Volts			
KS-5483 L01	S7	Volts DC	20		
KS-5483 L02	S7	Volts DC	20 (note 7)		10
KS-5483 L03	S7	AC Volts	105		
KS-5483 L04	S7	Volts DC	125		
KS-5483 L05	SC7	Volts DC	42		
KS-5483 L06	SS7	AC Volts	207		
KS-5483 L07	S7	AC Volts	190		
KS-5483 L08	S7	Volts DC	42		
KS-5483 L09	S9	AC Volts	105		
KS-5483 L10	S9	Volts DC	20		
KS-5483 L11	L2	AC Amps	17		0
KS-5483 L12	S9	AC Volts	207		
KS-5483 L13	S9	AC Volts	207 (note 1)		
KS-5483 L14	S9	Volts DC	40		
KS-5483 L20	C7	AC Volts	5.8		
KS-5483 L20A	A7	AC Volts	5.0		
KS-5483 L21	C7	Volts DC	20		
KS-5483 L22	C7	Volts DC	125		
KS-5483 L23	C7	AC Volts	18		
KS-5483 L24	C7	Volts DC	42		
KS-5483 L25	C7	Volts DC	18		
KS-5483 L26	C7	Volts DC	17		
KS-5483 L27	C7	Volts DC	98		
KS-5483 L28	C7	Volts DC	125		
KS-5483 L29	C7	Volts DC	30		
KS-5483 L30	C7	AC Volts	207		
KS-5483 L31	C9	AC Volts	105		
KS-5483 L32	C9	Volts DC	20		
KS-5483 L33	C9	Volts DC	42		
KS-5483 L34	C9	AC Volts	207		
KS-5483 L35	C9	AC Volts	207 (note 1)		
KS-5483 L36	C9	AC Volts	20		
KS-5483 L37	C9	Volts DC	125		
KS-5483 L38	C9	Volts DC	9		
KS-5483 L39	C9	AC Volts	344		
KS-5483 L40	C9	(AC Volts	70		
		(Volts DC	15	13	(note 8)
KS-5483 L41	A7	AC Volts	52		
KS-5483 L42	A7	Volts DC	120 (note 5)		
KS-5483 L43	A7	AC Volts	105		
KS-5483 L44	A7	AC Volts	100		
KS-5483 L51	A8	AC Volts	104		
KS-5483 L52	A8	Volts DC	42		
KS-5483 L53	A8	Volts DC	70 (note 2)		
KS-5483 L54	A8	Volts DC	105		
KS-5483 L55	A8	AC Volts	18		
KS-5483 L56	A8	AC Volts	207		
KS-5483 L57	A8	Volts DC	120		
KS-5483 L58	A8	AC Volts	207 (note 1)		
KS-5483 L59	A8	Volts DC	9		
KS-5483 L61	C8	Volts DC	27		
KS-5483 L71	A9	Volts DC	20		
KS-5483 L72	A9	AC Volts	104		
KS-5483 L73	A9	Volts DC	42		
KS-5483 L74	A9	AC Volts	207		
KS-5483 L75	A19	Volts DC	105		
KS-5483 L80	D6	Volts DC	125		
KS-5483 L81	D6	AC Volts	20		
KS-5483 L82	D6	Volts DC	20		
KS-5483 L83	D6	AC Volts	105		
KS-5483 L85	D6	Volts DC	42		
KS-5483 L91	B10	AC Volts	100		
KS-5483 L92	B28	AC Volts	100 (note 3)		
KS-5483 L93	B1	Volts DC	10		

SECTION 040-816-701

Relay	Type	Values in	Min Operate	Nonoperate	Release
		AC Volts at 60 Cycles or DC Volts			
KS-5483 L94	B1	Volts DC	20		
KS-5483 L95	B6	AC Volts	100 (note 3)		
KS-5635 L01	-	Amps DC	0.060 (note 4)		
KS-5635 L02	-	Volts DC	20		
KS-5635 L03	-	Volts DC	20		
KS-5635 L04	-	Volts DC	22		
KS-6319	E	Volts DC	32		
KS-6724	E	Volts DC	45		
KS-8854	-	Volts DC	105		
		AC Volts	105 (Note 9)		
KS-15601 L1	-	AC Volts	105		

Notes:

1. Values given for KS-5483, Lists 13, 35, and 58 are at 50 cycles; all other ac ratings are at 60 cycles.
2. KS-5483, List 53 when in series with 800 ohms has a dc operate value of 125.
3. Values given for KS-5483, Lists 92 and 95 are on 60 cycles. The same values will apply on 25 cycles if 800 ohms are in series with the coil and will also apply on dc if 1000 ohms are in series with the coil.
4. KS-5635, List 01 operate value is for either coil separately energized.
5. KS-5483, List 42 shall not operate on any 60-cycle ac voltage up to 130, and if operated on dc it shall release if any 60-cycle ac voltage up to 130 is substituted for the dc.
6. Values given for KS-5381, Lists 5 and 15 apply when voltage is connected between terminals 2 and 3.
7. KS-5483, List 02 shall operate at 22 volts max and release at 11 volts min.
8. The dc voltage values for KS-5483, List 40 apply with the coil cold (25C).
9. The values given for KS-8854 are with a 700-ohm resistor in series with the coil. The ac operate volts apply on either 25 or 60 cycles.

3. ADJUSTING PROCEDURES

3.001 List of Tools, Gauges, Materials, and Test Apparatus (Equivalents may be substituted)

Tools

Adjuster, No. 356

Adjuster, spring, No. 363 tool
(The Signal Engineering and Manufacturing Company's T-40010 tool is suggested where a large number of split springs, other than those on KS-5635 relay, are to be adjusted or where access to springs from the side is impossible. A similar tool can be made as shown in Fig. 6 for use on KS-5635 relays and on relays not having split springs.)

Bond Paper, KS-7187

Burnishing Tool, No. 265C

Clip, No. 385 tool (two reqd per cord for strapping, one reqd per cord for use with flashlight)

Cord, No. 1W13A

Flashlight equipped with KS-14250, List 12 bottom cap

Pliers, duck-bill, KS-6015

Pliers, P-long nose, 6-1/2 inches

Screwdriver, 3-inch cabinet - For bending backstop tang where there is no backstop adjusting screw

Screwdriver, 3-1/2 inches, KS-6854 (part of No. 221 tool) - For adjustments and smaller assembly screws

Screwdriver, 4 inches, regular - For terminals and larger assembly screws

Stick, orange, KS-6320

Wrench, 5/16-inch and 7/32-inch hex. openings - No. 418A tool

Wrench, 3/8-inch and 1/4-inch hex. openings - No. 417A tool

Wrench, socket, 3/8-inch hex. opening - No. 46 tool

Wrench, socket, 3/16-inch hex. opening - No. 220 tool which is part of No. 221 tool is suggested

Wrench, socket, 5/16-inch hex. opening - R2787

Wrench, socket, 7/16-inch hex. opening - R2788

Gauges

Ammeter, ac, Weston Model No. 528, 50 range

Gauges, fan type

No. 70F (10-0-10)

No. 70H (0-30)

No. 70D (50-0-50)

No. 70G (50-0-50)

No. 68B, C, or D (70-0-70)

No. 70J (0-150)

Gauge, push-pull, tension No. 79C, 0-200 grams

Gauge, thickness

P-247349, 0.033 inch (part of KS-6938)

R-80223, 0.060 inch

No. 132AD, 0.074 inch

No. 119A, 0.092 inch

R-2310, 0.125 inch

Scale, steel, 6 inches, R-8550

Voltmeter, ac, Weston Model No. 528 - Ranges 300-150

Voltmeter, dc, Weston Model No. 280 - Ranges 150-60-3 or 180-60-3

Materials

Cloth, abrasive, 100 grade

Cloth, cleaning, KS-14666

Spirits, petroleum, KS-7860

Test Apparatus

Autotransformer, continuously tapped - (Variac, 2.5 amp, type V-5HMT, General Radio Co, Cambridge, Mass., suggested)

Test Set, 35 type, or other variable resistor

Transformer, No. 352AL

3.002 Strapping and Insulating: To maintain service while work is being done affecting closed contacts of working circuits, bridge the live contacts, making the connections at the most convenient points in the circuit other than at the relay if practicable. No. 1W13A cords (3 ft 0 in.) with No. 365 clips at each end are suggested for strapping, provided voltages do not exceed 150. No. 1W13B cords (6 ft 0 in.) or KS-6278 clips are equally satisfactory as are also lengths of No. 14 wire with KS-6780 clips or universal test clips (Graybar Catalogue). Bond paper used for insulating live parts should be shaped or bent as necessary to provide protection with a minimum of interference with the work being done.

3.003 General Procedure

- (1) It is recommended that requirements be checked and any required adjustments be made in the order outlined in the following paragraphs. When relays are used on applications where a failure would not cause service reactions, the periodic check of mechanical requirements outlined in 3.02 through 3.07 may be omitted by the telephone company upon approval of supervisor.
- (2) When checking mechanical requirements and readjusting, relay should be removed from the working circuit if possible. If there is doubt as to the exact instant of making and breaking of contacts, the use of a buzzer or lamp across the contacts is suggested. When necessary, paralleled contacts can be insulated with strips of bond paper as required. The No. 35D test set lamp signal can be used to indicate contact closure as

outlined in Section 100-101-101. A flashlight equipped with KS-14250, List 12 bottom cap, two No. 1W13A cords, and two No. 365 clips can also be used for this purpose. This procedure can not be used on a live relay. If it becomes necessary to remove the relay from its mounting in order to obtain access to the parts, proceed as follows. Disconnect all power supply from the relay winding and contact circuits by opening switches if provided, or by removing the fuse or fuses. Then disconnect the leads from the relay terminals, using the 4-in. regular screwdriver or 3/8-inch wrench. Unsolder leads on KS-5635 and KS-15601 relays. Remove the relay mounting screws with the 4-inch regular screwdriver. Where it is not possible to remove the relay from the working circuit, bridge around contacts (see 3.002), insulate between contacts with a strip of bond paper, and disconnect leads, as necessary, in order to maintain circuit conditions unchanged. Use caution when working in close quarters with live parts.

3.01 Tightness of Assembly (Rq 2.01)

- (1) Tighten spring assembly mounting screws with the KS-6854 screwdriver.
- (2) If riveted springs are loose, replace the spring assembly or armature assembly as required.

3.02 Contact Surfaces (Rq 2.02)

- (1) In working circuits, contacts which are closed and carrying current which cannot be broken should be bridged (see 3.002). Use caution when working in close quarters with live parts. In working circuits, contacts which are open and should not be closed shall be kept separated by inserting a strip of bond paper between the movable and stationary contacts, or a lead should be disconnected. To close a normally open contact, hold armature against pole face. Normally closed contacts which are operated in a working circuit may be closed by opening one connection to the coil after first bridging or insulating the other contacts, as necessary.
- (2) The purpose of cleaning contacts is to remove any gummy or dirty substance that would interfere with reliable contact. It is not necessary or desirable to keep contacts polished or shining. Clean contacts by wiping with a cloth moistened with petroleum spirits. The colored lacquer (red on D-type relays) needs to be burnished off only when interfering with operation.
- (3) Carbon contacts shall not be dressed. On other contacts there shall be as little smoothing of contacts as consistent with satisfactory operation. In dead circuits insert a burnishing tool, thin file, or strip of abrasive cloth (with live contacts, abrasive cloth only) between the con-

SECTION 040-816-701

tacts to be cleaned, and draw it back and forth until the burrs are removed entirely or are reduced considerably. Then clean the contacts as outlined in (2) above.

3.03 Contact Alignment (Rq 2.03)

(1) Straighten out any bows or bends in the contact springs as outlined below. Do not straighten kinked springs unless the kink interferes with the proper adjustment of the spring assembly. Removing kinks tends to weaken the spring and shorten the life of the spring assembly.

(a) To straighten a bowed spring that is accessible from the side, apply the duck-bill pliers at the far end of the bow and adjust the spring slightly in the opposite direction to the bow and then while applying only enough pressure to the spring to hold it away from any support, draw the pliers along the length of the bow, pausing momentarily at each 1/16 inch of the spring to apply a slightly greater pressure than the drawing pressure in a direction opposite the bow. Repeat this operation until a satisfactory adjustment has been obtained. If the spring is bent or if it is necessary to remove a kink, follow the same procedure as outlined for a bowed spring except that it will only be necessary to adjust the spring from approximately 1/4 inch beyond the bend to approximately 1/4 inch in front of the bend. When access to the springs from the side is impossible, follow (b) below. The method of straightening split contact springs is outlined in 3.04(2). On KS-5635 relays, a further slight adjustment can be made by loosening contact spring clamping screw and then moving the contact spring assembly as required. Retighten screw.

(b) For this work duck-bill pliers, No. 363 tool having 0.018-inch straight slot, No. 356 tool having 1/16-inch and 0.025-inch, 90-degree slots, T-40010 tool shown in Fig. 7, or a tool made locally per Fig. 6 should be selected, depending on number, size, and location of springs to be adjusted, location of relay, and adjacent apparatus, etc. With heavy springs such as found on E-type relays, pliers must be used even if this makes removal of the relay from the panel necessary. For the

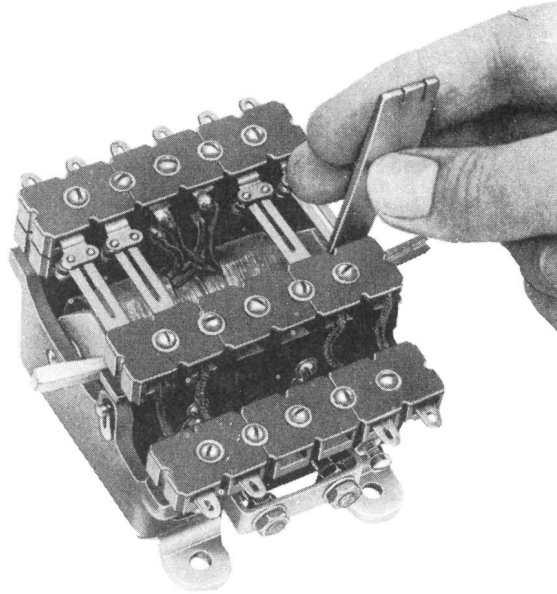

Fig. 7 - Method of Adjusting Contact Springs Using T-40010 or Fig. 6 Tool and Method of Blocking KS-5635 Relay Operated

inside springs of KS-5635 relays, No. 356 tool, T-40010 tool, or a tool per Fig. 6 is preferred. For the inside spring of A-type relays, the T-40010 tool is most convenient. The use of T-40010 tool and tool per Fig. 6 is illustrated in Fig. 7.

(2) It is expected that no further adjustments will be necessary. However, on some relays a further adjustment can be made by changing the position of the stationary contacts consistent with meeting other requirements such as contact separation, sequence, and pressure.

(a) D-type relays have a hexagonal contact locking nut and a hexagonal contact adjusting nut as shown in Fig. 2. To change the position of the stationary NC contacts on this relay, loosen the contact locking nut with a wrench and then turn the contact adjusting nut in or out as required. On relays such as the D-type where the stationary NC contact is on a metal supporting arm, contact position can be changed by bending the arm with pliers.

(b) Some C-, S-, SC-, and SS-type relays have hexagonal contact adjusting and locking nuts and can be adjusted in the same manner as the D-type relay above. C-, S-, SC-, and SS-type relays with NC contacts that are not equipped with hexagonal contact adjusting and locking nuts can be adjusted, if necessary, by using a small spanner wrench. If desired, a suitable

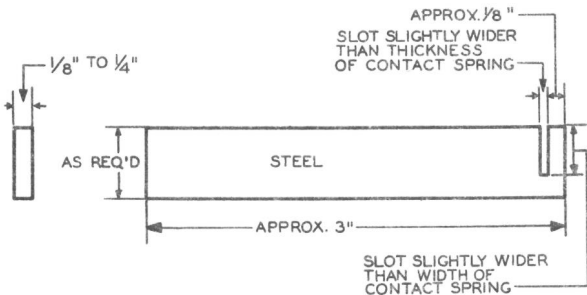

Fig. 6 - Method of Making Adjusting Tool

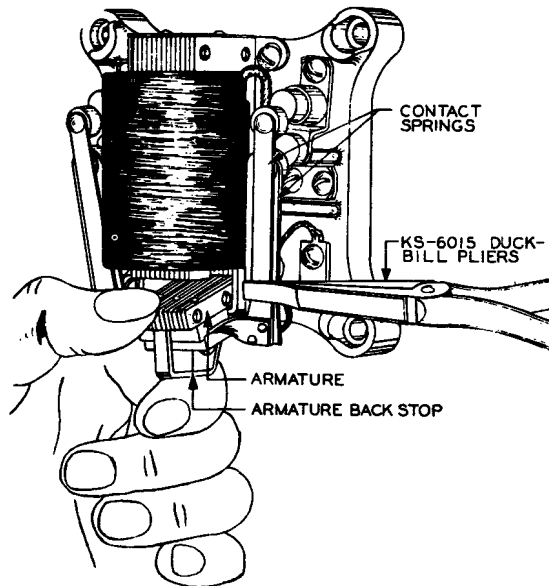

Fig. 8 - Method of Adjusting for Contact Pressure and Contact Sequence

spanner wrench may be obtained from Signal Engineering and Manufacturing Company, 273 Branchport Avenue, Long Branch, N.J., by mentioning the code number of the relay to be adjusted.

(c) The position of the stationary contacts can be changed slightly by loosening stationary contact clamping screws on KS-5635 (see Fig. 3) or stationary clamping nuts on KS-15601 (see Fig. 4) and moving the stationary contact assembly as required. Retighten screws or nuts. To further change position of stationary NC contacts, carefully bend contact arm with long-nose pliers, as required. On KS-5635 relays the two inside lower stationary con-

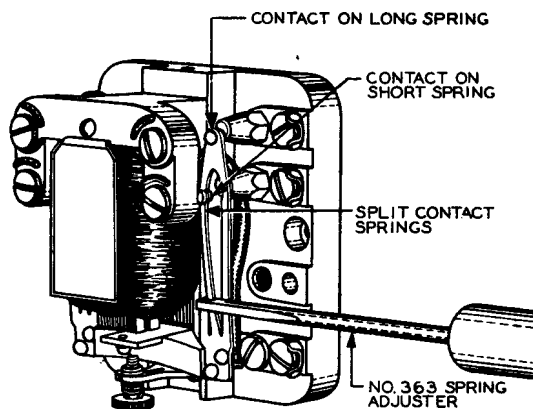

Fig. 9 - Method of Adjusting for Contact Sequence on Split Contact Springs

tact arms can not be reached with pliers and should seldom require bending. However, they can be bent by prying up with a screwdriver or tapping down with a screwdriver and hammer. Use care especially where porcelain contact support blocks are provided.

(3) If alignment cannot be obtained, install a new relay.

3.04 Contact Sequence (Rq 2.04)

(1) On relays not having split springs, adjust for contact sequence as required with the duck-bill pliers. To do this, place the pliers at a point about 1/4 inch from the point where the spring is riveted to the armature as shown in Fig. 8 and adjust the spring at this point, as required. When access to the springs from the side is impossible and for KS-5635 relays, follow 3.03(1)(b). When a satisfactory adjustment cannot be obtained in this manner, distribute the tension as outlined in 3.03(1). It is expected that no further adjustments will be necessary. However, on C-, D-, S-, SC-, SS-type, KS-5635, and KS-15601 relays, further adjustment can be made by changing the position of the stationary contacts as outlined in 3.03(2). If any adjustments are made, recheck alignment (2.03).

(2) With the exception of KS-5635 and KS-15601 relays which are covered in (1) above, if the relay is equipped with split contact springs and the contact on the long spring does not close at the same time as the contact on the short spring, the trouble may be due to an unsatisfactory position of either the long or short spring. If either leg of the long spring is bowed or bent, straighten it with the duck-bill pliers as outlined in 3.03(1) and adjust the short spring as follows: Place the No. 363 spring adjuster on the short spring just below the contact. This may be facilitated by lifting the short spring with a toothpick. Slide the adjuster back along the spring as far as possible without forcing as shown in Fig. 9. Adjust the spring as required. Take care when doing this, as in general, only slight adjustment of the spring is necessary. Slide the spring adjuster toward the free end of the spring and then withdraw it. If difficulty is experienced in obtaining simultaneous closure of contacts on both NO and NC contacts, give preference to the NC contacts in making the adjustment, as the movement of the armature will, in general, overcome any slight differences in the closure of the contact. When access to the springs from the side is impossible, follow 3.03(1)(b). If any adjustments are made, recheck alignment (2.03).

3.05 Contact Pressure (Rq 2.05)

(1) Contact pressures have a direct bearing on the electrical requirements. If the contact pressure is greatly in excess of the specified minimum limit, the relay may fail

to meet its electrical requirements, and on relays with NC contacts it may be found necessary to reduce the tension of the retractile spring. When readjusting, it is desirable to have the tension as great and equal as possible on the various contact springs, consistent with meeting other requirements. The pressure should be approximately equal on corresponding springs of the assemblies on both sides of the armature. Either the fan-type gauge or the tension gauge may be used for measuring contact pressures, whichever is more convenient. When one contact spring is bent or otherwise changed, or when the position of a stationary contact is changed, recheck the contact pressure on all the contacts on the relay.

Note: Ac relays may hum or chatter due to excessive pressure on the NO contacts, in which case the contact pressure should be reduced until the hum or chatter disappears, but the pressure should not be reduced below the minimum. Humming or chattering may also be due to excessive pull on the retractile spring.

(2) **Normally Open Contacts:** While checking pressure on NO contacts the relay must be held or blocked operated. The KS-5635 relay can be blocked operated with a small wedge on each side of the armature, as shown in Fig. 7. If the pressure between contacts is not satisfactory, hold the armature against the backstop and increase the tension of the spring, adjusting it towards the contact by applying the KS-6015 duck-bill pliers close to the riveted base of the spring, as shown in Fig. 8. In adjusting the springs, exercise care not to twist them, since this will prevent the contacts from resting flat against each other. When access to the springs from the side is impossible, follow 3.03(1)(b). If the spring is bowed or bent, follow 3.03(1). If a satisfactory adjustment of split contacts cannot be obtained as outlined above, make further adjustments in accordance with 3.04(2). On KS-5635 and KS-15601 relays a further adjustment can be made as outlined in 3.06(5). If any adjustments are made, recheck alignment (2.03) and sequence (2.04).

(3) **Normally Closed Contacts:** Checking and adjustment of pressure on NC contacts must be made after the adjustment of the NO contacts, and if bending or other change of the contact springs is necessary during adjustment of NC contacts, recheck NO contact pressure (2.05), alignment (2.03), and sequence (2.04). The contact pressure between NC contacts should be measured after electrical release of the relay. If it is not convenient to do this, operate the relay manually and then release it, allowing the movable contacts to spring back against the stationary NC contacts so as to simulate electrical release and contact pressure under operating conditions. If the pressure between NC contacts is not satisfactory and the

pressure between all NC contacts is approximately equal, try to obtain a satisfactory adjustment by changing the tension on the armature retractile springs, if any, as outlined in (a) to (d) below. If pressure between the NC contacts on any relay varies considerably, follow (d) below.

- (a) For such types as A, B, and C, having knurled nut adjusting screw, as shown in Fig. 2, turn with the fingers (in some cases a 4-inch regular screwdriver may be required) clockwise to decrease retractile spring tension and counterclockwise to increase retractile spring tension.
- (b) For such types as L, S, KS-8854, and KS-15601, having hexagonal head adjusting screw, as shown in Figs. 2 and 4, back off locknut with hexagonal open-end wrench, pull out the hexagonal-headed screw slightly by its head, and turn with the fingers clockwise to increase retractile spring tension and counterclockwise to decrease it. Retighten locknut.
- (c) For KS-5635 relays with hexagonal retractile spring adjusting nuts and locknuts, as shown in Fig. 3, loosen the locknuts with hexagonal open-end wrench or No. 220 wrench, and turn adjusting nuts with KS-6320 orange stick if relay is alive, or with finger, orange stick, or small screwdriver if relay is dead. Early models of this relay had hexagonal head adjusting screws and hexagonal locknuts which can be turned as required with socket wrenches R2787 and R2788. The adjusting screw must be held stationary while the locknut is being turned. Clockwise turning of the adjusting nut or screw increases retractile spring tension and counterclockwise turning decreases tension. The tension on the two

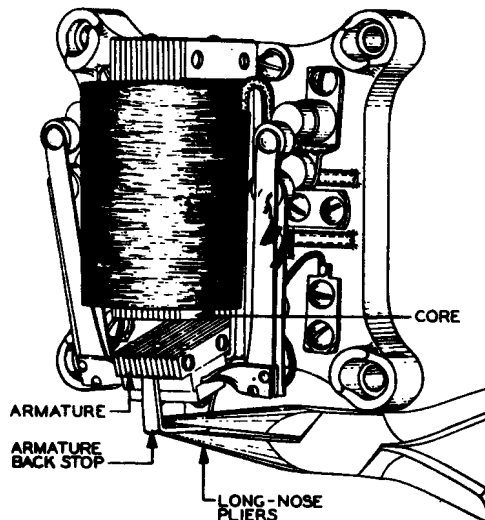

Fig. 10 - Method of Adjusting Armature Backstop - Using Long-nose Pliers

Retractable springs must be maintained approximately equal. To do this, turn each adjusting nut or screw the same amount. Retighten locknuts.

(d) Unless necessary, do not adjust contact springs. If adjustment is necessary, hold the armature against the core and grasp the spring to be adjusted with the duck-bill pliers close to the point where the spring is riveted to the armature and adjust the spring toward the stationary NC contact to increase the tension. To decrease the tension hold the armature in the nonoperated position (against the backstop, if any) and adjust the spring away from the stationary NC contact with the duck-bill pliers. When a satisfactory adjustment cannot be obtained in this manner, it is probably due to a bowed or kinked spring, in which case distribute the tension by adjusting the spring as outlined in 3.03(1). When access to the springs from the side is impossible, follow 3.03(1)(b). If a satisfactory adjustment of split contact springs cannot be obtained as outlined above, make further adjustments in accordance with 3.04(2). A further adjustment can be made on C-, D-, S-, SC-, SS-type, KS-5635, or KS-15601 relays with normally closed contacts by changing the position of the stationary NC contacts as outlined in 3.03(2) and then rechecking alignment (2.03) and sequence (2.04).

3.06 Contact Gap (Rq 2.06)

(1) If a gauge of conducting material is used, the contacts must be dead while checking gap. Contact gaps and armature air gaps of relays of the type shown in Fig. 10 are corrected by adjusting the armature backstop with the long-nose pliers.

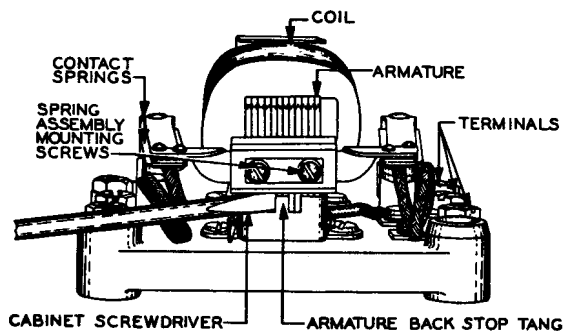

Fig. 11 - Method of Adjusting Armature Backstop Tang - Using 3-inch Cabinet Screwdriver

(2) To decrease contact gap and armature air gap of relays of the type shown in Fig. 11, insert the blade of the 3-inch cabinet screwdriver between the armature backstop tang and the backstop frame. Using the screwdriver as a lever, bend the backstop

tang toward the armature by pressing the screwdriver against the tang. If the contact gap or armature air gap is too small, correct it by inserting the screwdriver between the backstop tang and the frame as shown in Fig. 11. Using the screwdriver as a lever, pry the tang away from the armature. Exercise care not to break the tang which is short and somewhat brittle.

(3) On relays equipped with armature backstop adjusting screws as shown in Fig. 2, loosen the armature backstop adjusting screw locknut with the No. 220 or R2787 wrench while holding the adjusting screw in position with the KS-6854 screwdriver. Turn the adjusting screw in or out as required to decrease or increase, respectively, the movement of the armature. Where a coiled retractile spring blocks access to backstop adjusting screw, unhook the spring with care to avoid deforming spring. On relays where the bottom of the spring is screwed over a stud and the stud riveted to a bracket which is secured to the frame by two screws, remove the screws. After a satisfactory adjustment is obtained, tighten the locknut securely while holding the screw in position.

(4) When a change in air gap or contact gap on a C-, D-, S-, SC-, or SS-type relay with normally closed contacts is necessary, it can be made by changing the position of the NC contacts as outlined in 3.03(2). If any change is made, recheck alignment (2.03), sequence (2.04), and pressure (2.05).

(5) Contact gap on KS-5635 and KS-15601 relays can be adjusted by carefully bending stationary contact arms as outlined in 3.03(2)(c). If any adjustment is made, recheck alignment (2.03), sequence (2.04), and pressure (2.05). The backstop adjusting screw on KS-5635 relays should not be changed from its factory setting.

(6) To increase contact gap on relays having only NC contacts with an insulated backstop (see type L shown in Fig. 2), file or grind only enough from the end of the insulated backstop to give a minimum gap. Removal of too much material from the backstop will cause contact springs to whip.

3.07 Relay Mounting (Rq 2.07)

(1) Tighten loose mounting screws with 4-inch regular screwdriver.

3.08 Electrical Requirements (Rq 2.08)

(1) A rough check of the operation of a voltage-rated relay is made by connecting a voltmeter across the coil terminals. If there is no reading on the voltmeter, a study of the associated circuit is necessary to find whether the absence of voltage indicates a circuit fault or is a condition to be overcome by blocking another relay in the circuit or otherwise changing

circuit conditions. Failure to operate with rated voltage or higher at the coil terminals may sometimes be corrected by readjustment but in some cases it may be due to an open coil. To check for an open coil, connect the voltmeter in series with the operating voltage and the coil, with parallel coils, if any, disconnected. No reading on the voltmeter when connected in series, after a reading when connected in parallel with the coil, indicates that coil is open and should be replaced. (If available a volt-ohmmeter can be used to check for an open coil or a coil with shorted turns.)

(2) A rough check of the operation of a current-rated relay is made by connecting an ammeter in series with the relay coil. Failure to operate at rated amperes or higher would call for readjustment of the relay. If ammeter shows no reading, check with a voltmeter from each coil terminal, first to one side of the battery or line (grounded side first if any) and then to the other side. A voltage reading to one coil terminal and none to the other from the same side of the battery or line would indicate that the coil was open and should be replaced.

(3) When readjusting or when checking for any electrical requirement except the rough check of operation discussed in (1) and (2) above, the relay or switch should be removed from the working circuit if possible. Where this is not possible, bridge around contacts (see 3.002), insulate between contacts with a strip of bond paper, or disconnect leads, as necessary, in order to maintain circuit conditions unchanged. Use caution when working in close quarters with live parts. Disconnect one or both coil terminals before making test connections discussed in (4), (5), or (6) below.

(4) Where requirements are expressed in miliamperes it is direct current unless otherwise specified, and a No. 35C or No. 35D test set should be used. Where requirements are in volts it is direct current unless otherwise specified, and a No. 35D test set or a No. 35C test set supplemented by a dc voltmeter should be used. Where test set preparation has not been specified on the Circuit Requirements Table, it is suggested that both relay coil terminals be disconnected and both battery and ground be furnished through the test set with B/G or B/G/V preparation.

(5) Where electrical requirements are expressed in volts alternating current, connect the ac supply to the input of a continuously tapped autotransformer protected by a 2-1/2- or 3-ampere fuse. Connect the relay coil and a voltmeter across the output of the autotransformer and adjust to specified values.

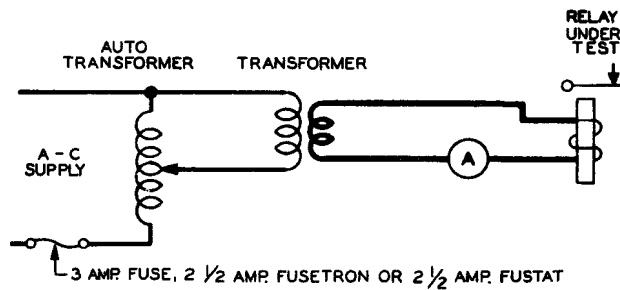

Fig. 12 - Test Connections Where Relay Is Rated in Amperes AC

(6) Where electrical requirements are expressed in amperes alternating current, an autotransformer should be used. Where current in excess of the output rating of the autotransformer is required, a transformer should be added as shown in Fig. 12. If the No. 352AL transformer is used, terminals 1 and 3 are connected to the relay and terminals 4 and 210, 230, or 250, depending on line voltage, are connected to the output of the autotransformer. With the above arrangement, current up to 60 amperes at 2.25 volts alternating current can be obtained by manipulation of the autotransformer. For test purposes, the current should be gradually increased to the specified operate value and gradually reduced to the specified release value.

(7) Operate, nonoperate, and release adjustments may be made by changing contact pressures, but in no case should the pressure be less than the specified minimum. Changes in these values may also be made by changing the air gap between the armature and the pole face as outlined in 3.06.

(8) If the armature moves toward the core as the electrical operate current is applied, but fails to pull all the way up to the core, it is an indication of excessive contact pressure, a bind in the pivot structure, an obstruction in armature gap, or excessive armature retractile spring tension. Reduce the contact pressure as outlined in 3.05, exercising care not to change the contact sequence. If the armature retractile spring tension is excessive, reduce the tension as outlined in 3.05(3).

(9) If the relay fails to meet its nonoperate requirement, increase the armature air gap as covered in 3.06, and if the relay is equipped with an armature retractile spring, increase the tension as outlined in 3.05(3). If a readjustment of the contact pressure is necessary, proceed as covered in 3.05.

(10) If the relay does not release, check each armature for binding in its fulcrum, and clean or replace. Check each retractile spring to see that it has sufficient tension to return the armature to its own position. Replace if sufficient tension cannot be obtained by adjusting spring as outlined in 3.05(3). If stop pin in armature face (see Fig. 1) allows the armature to come into direct contact with the pole face and permits it to stay there after

the actuating current or voltage is interrupted, renew the armature.

(11) In some cases the armature or pole face may require cleaning with petroleum spirits on a cloth supported over a screwdriver.

(12) When any change is made in mechanical settings during adjustment for electrical requirements, recheck mechanical requirements.