

STROMBERG-CARLSON RELAYS
194, 207, 228, 244, 245, 253, 257, 263, 285 AND 366 TYPES
REQUIREMENTS AND ADJUSTING PROCEDURES

1. GENERAL

1.01 This section covers the apparatus requirements and adjustment procedures for 194-, 207-, 228-, 244-, 245-, 253-, 257-, 263-, 285-, and 366-type Stromberg-Carlson relays and the procedures for applying removable paper separators to such of these relays as are covered in Section 040-014-811.

1.02 This section has been reissued to provide correct references to other Plant Series sections. In this process marginal arrows have been omitted.

1.03 Reference shall be made to Section 020-010-711 covering general requirements and definitions for additional information necessary for the proper application of the requirements listed herein.

***1.04 Asterisk:** Requirements are marked with an asterisk (*) when to check for them would necessitate the dismantling or dismantling of apparatus, or would affect the adjustment involved or other adjustments. No check need be made for these requirements unless the apparatus or part is made accessible for other reasons or its performance indicates that such a check is advisable.

1.05 Operate

(a) **194-type Relays:** A relay is said to *operate* if, when current is connected to its winding, the armature moves sufficiently to cause the front contact to make.

(b) **366-type Relays:** A relay is said to *operate* if, when current is connected to its winding, the armature moves sufficiently to cause the front contact to make and at least one of the stop discs to touch the heelpiece.

(c) **All Relays Except 194- and 366-type Relays:** A relay is said to *operate* if, when current is connected to its winding, the arma-

ture moves sufficiently to cause all back contacts to break and all front contacts to make, and unless otherwise specified on the circuit requirement table, causes the armature to touch the core.

1.06 Nonoperate: A relay is said to *nonoperate* if, when current is connected to its winding, the armature does not move sufficiently to close any front contact or to reduce the back contact pressure enough to cause an unreliable contact.

1.07 Hold: A relay is said to *hold* if, after the relay has operated and the current is either reduced abruptly or is interrupted momentarily, the armature does not move sufficiently to cause contacts that have been made to become unreliable or to make contacts that have been broken.

1.08 Release: A relay is said to *release* if the armature moves from the core sufficiently to break contacts that have been closed and to make contacts that have been broken.

1.09 Residual Air Gap: *Residual air gap* is the distance between the face of the relay core and the inner surface of the armature with the relay electrically operated and the residual screw or paper separator touching the core.

1.10 Armature Travel

(a) **Of 194-type relays** is the distance between the contact on the armature and the front contact.

(b) **Of 366-type relays** is the distance between the stop discs on the armature or the KS-7743 separators when the relay is so equipped and the heelpiece.

(c) **Of 200-type relays equipped with adjustable residual screws** is the distance between the core and the residual screw.

(d) *Of all relays except 194-, 366-, and 200-type relays equipped with adjustable residual screw* is the distance between the core and the nearest point on the armature or the KS-7744 separator when the relay is so equipped.

1.11 The letters associated with the relay codes specified on the circuit requirement table indicate the spring combination figure. Where two letters are associated with the code, the relay is equipped with two spring combinations. The letter "Z," when included in the code of a 200-type relay, indicates that the relay is a slow release relay.

2. REQUIREMENTS

Requirements General (All Types of Relays)

(2.01 to 2.08 Incl.)

2.01 Cleaning

- (a) Contacts shall be cleaned when necessary as outlined in Section 069-306-801 covering cleaning of relay contacts and parts.
- (b) Other parts shall be cleaned in accordance with approved procedures.

2.02 **Contact Alignment:** Fig. 1(A) — Contacts shall line up so that the point of contact falls wholly within the boundary of the opposing contact.

Gauge by eye.

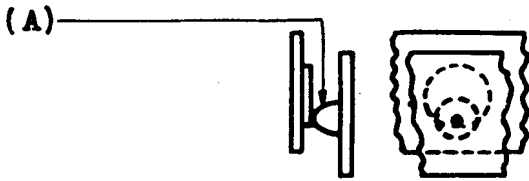

Fig. 1

2.03 **Tightness of Assembly:** All springs in a given assembly shall be held securely in their relative position to one another.

Gauge by feel.

2.04 **Straightness of Springs:** All springs shall be free of sharp bends or kinks due to adjustment. A gradual bow in a spring is permissible.

Gauge by eye.

2.05 Armature Travel

(a) Unless otherwise specified, the armature travel shall be in accordance with the value specified for the relay in the "Arm. Trvl." column on the circuit requirement table.

Use the No. 66D gauge or No. 74D gauge.

(b) Unless otherwise specified, the tolerance shall be

Test + .005" — .0025"

Readjust + .0025" — .0025"

(c) **Method of Checking:** To check the armature travel of 194-type relays, insert the specified gauge between the armature and the front contact. On 200-type relays equipped with an adjustable residual screw, insert the gauge between the residual screw and the core. On 366-type relays, insert the gauge between the stop discs on the armature or the KS-7743 separators when the relay is so equipped and the heelpiece. On all other type relays, insert the blade of the gauge between the core and the nearest point on the armature or the KS-7744 separator when the relay is so equipped.

2.06 **Contact Pressure:** The relays shall meet the contact pressure values specified on the figures on pages 3 and 4. These values shall be considered approximate values and the tension shall be consistent with meeting all the other requirements.

Use the No. 70D gauge for all relays except the 366-type relays which shall be gauged by feel.

(a) The particular spring combination figure or figures on pages 3 and 4 to be used are specified in the figure column of the circuit requirement table.

(b) When a relay has more than one spring tensioned against its armature stud or studs, each spring shall be tensioned against that part of the stud or studs against which it rests.

(c) The tension of the springs shall be measured at the end of the springs.

2.07 **Contact Separation:** The separation between contacts normally open or between contacts that are opened when the relay is operated shall be as specified on the figures shown on pages 3 and 4.

Gauge by eye.

2.08 Electrical Requirements: The relay shall meet the electrical requirements specified on the circuit requirement tables.

(Figs. A & A for 194 & 366 Type Relays) (Figs. A, B, C, D, H, L, M & N).

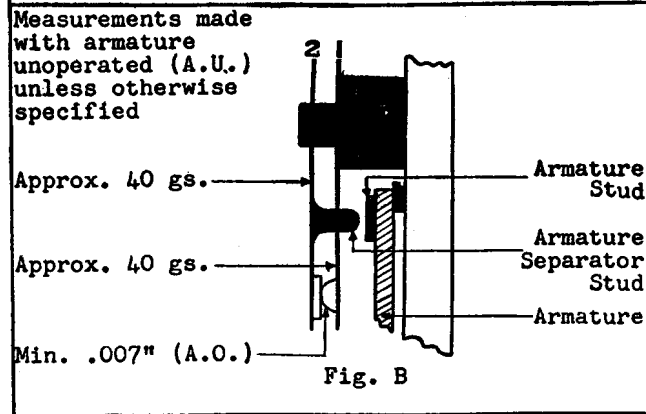
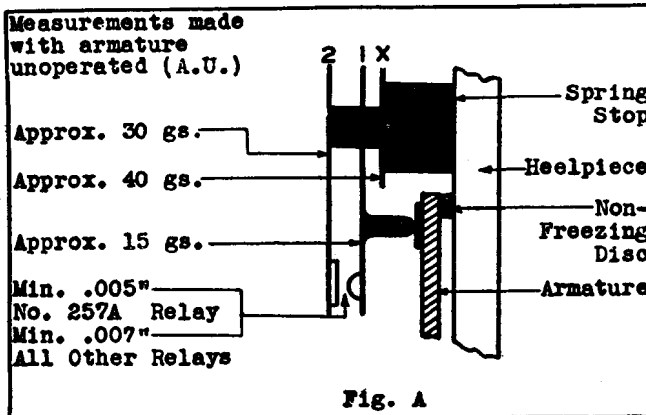

Variable Requirements 207-, 228-, 244-, 245-, 253-, 257-, 263- and 285-type Relays

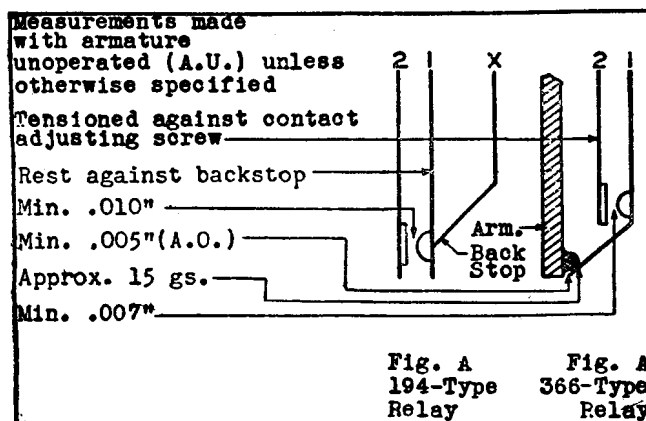

Variable Requirements 194- and 366-type Relays

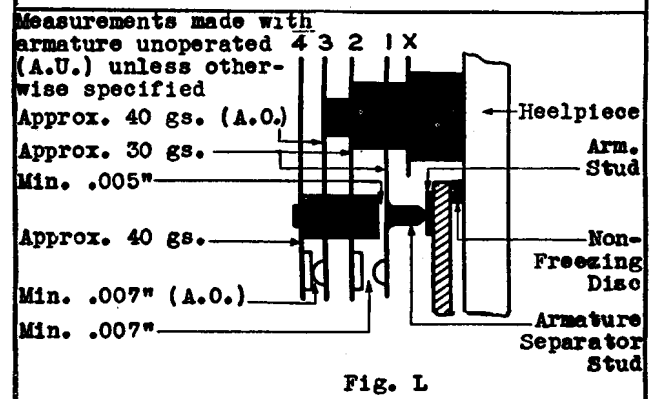
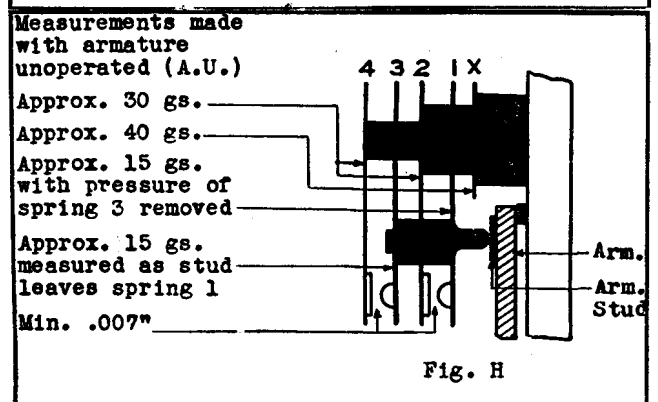
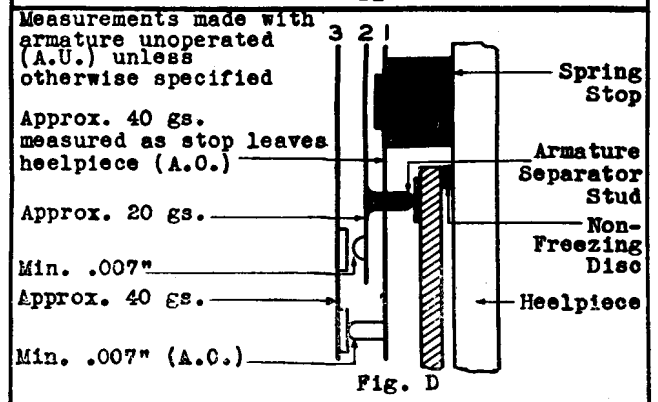
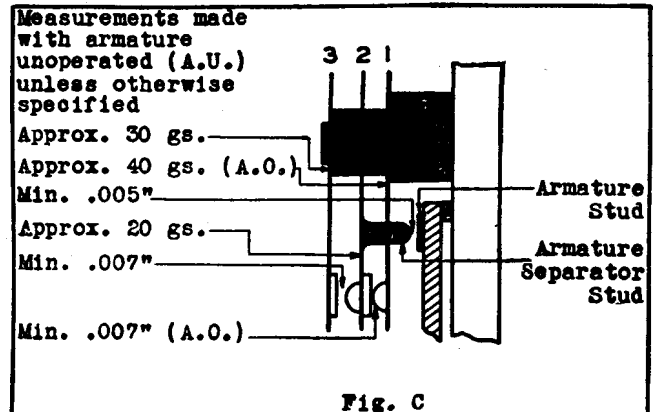

Variable Requirements 207-, 228-, 244-, 245-, 253-, 257-, 263- and 285-type Relays

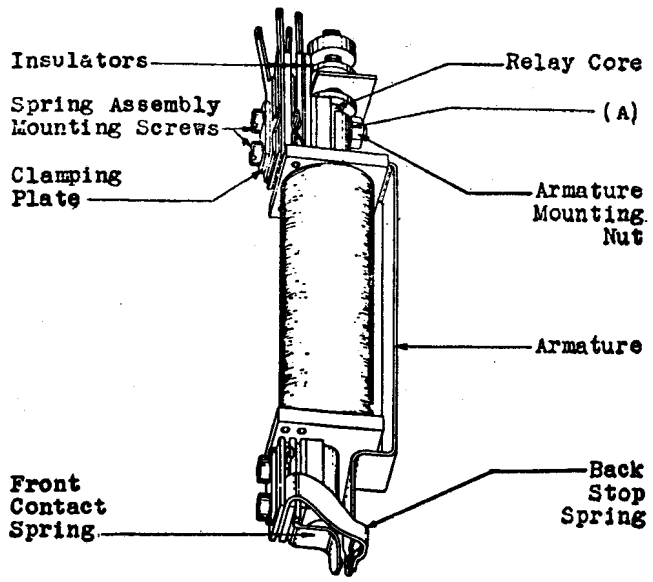
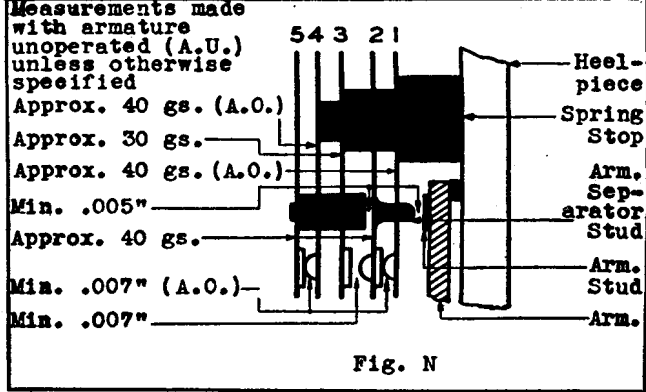
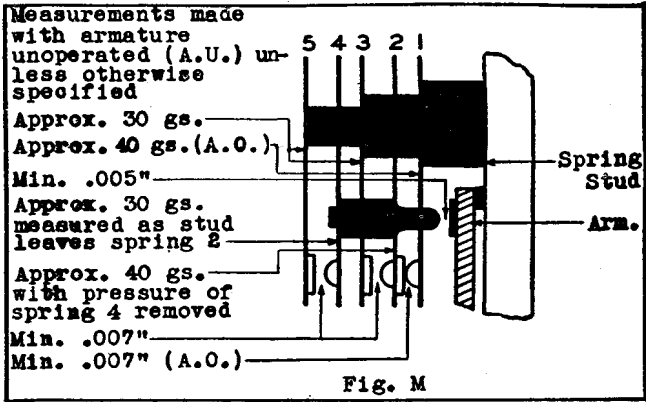

Fig. 2 - 194-type Relay

Variable Requirements 207-, 228-, 244-, 245-, 253-, 257-, 263-, and 285-type Relays

Requirements for 194-type Relays (2.09 and 2.10)

2.09 Relay Mounting: Fig. 2(A) — The armature shall be fastened securely to the relay core and the relay shall be fastened securely to the mounting strip.

Gauge by feel.

***2.10 Operated Armature Air Gap:** With the relay in the operated position, there shall be a clearance between the armature and the core of

Approx. .005"

Gauge by eye.

Requirements for 207- 228-, 244-, 245-, 253-, 257-, 263-, and 285-type Relays (2.11 to 2.18 Incl.)

2.11 Relay Mounting: Fig. 3(A) — The spool shall be fastened securely to the heel-piece and the heel-piece shall be fastened securely to the base plate. The base plate shall be fastened securely to the mounting strip.

Gauge by feel.

2.12 Tightness of Cover Nut: The cover shall be held securely in place by the cover nut. It shall not be so tight that the cover nut cannot be turned with the thumb and fingers. Gauge by feel.

2.13 Tightness of Cover: The cover shall fit snugly but shall not be so tight as to prevent placing or removing with the fingers. Gauge by feel.

2.14 Stud and Stop Clearance: Fig. 3(B) — The studs and stops shall not rub on the springs through which they pass when the armature is moved. Gauge by eye and feel.

2.15 Separation Between Springs: Fig. 3(C) — There shall be a clearance between springs designed never to touch in the operated or unoperated position of the relay of

Min. .010"

Gauge by eye.

2.16 Tightness of Retaining Screws: Fig. 3(D) — The armature retaining screw shall be held securely in place. Gauge by feel.

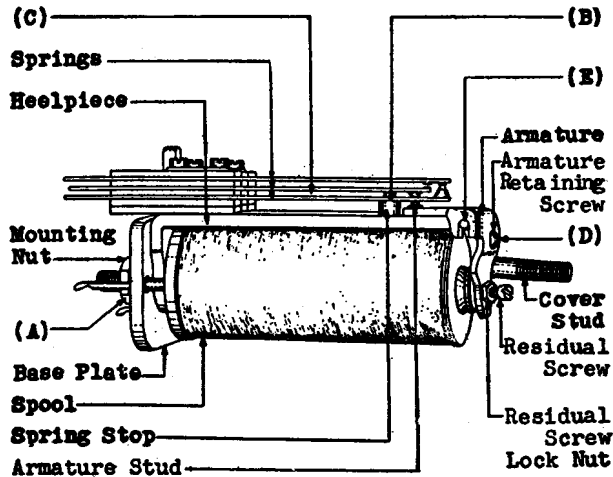

Fig. 3 - 207-type Relay

2.17 Armature Movement: Fig. 3(E) — The armature shall move freely in its bearings.

Gauge by feel.

2.18 Application of KS-7744 Separators: The KS-7744 separator, when applied in accordance with Section 040-014-811 covering the list of relays on which removable paper separators may be applied, shall be mounted so that when a separator is required between the armature and core, the single layer of paper is on the side of the armature next to the core. When a separator is required between the armature and stop discs, the single layer of paper shall be applied to the heelpiece and covers both stop discs.

2.19 Residual Air Gap: On relays equipped with an adjustable residual screw, the residual air gap shall be

Min. .003"
Max. .005"

To check the residual air gap, insert the proper blade of the No. 74D gauge between the armature and the core so that the residual screw is free to touch the core through the hole in the end of the gauge. Energize the relay electrically and then judge the residual air gap by the tightness of the gauge.

2.20 Stud Gap: The separation between the armature separator stud and the armature stud and between the stud and the spring

against which it normally rests when the relay is operated shall be as specified on the figures shown on pages 3 and 4.

Gauge by eye.

2.21 Contact Follow: The contact follow on normally open contacts shall be perceptible (approximately .005"). This is considered satisfactory if the contacts make with a .003" gauge (test) or a .004" gauge (readjust) inserted between the armature and the core. This should be checked when the relay is electrically operated on its specified "Test" or "Readjust" current.

Use the No. 66D gauge or No. 74D gauge.

Requirements for 366-type Relays (2.22 to 2.31 Incl.)

2.22 Relay Mounting: Fig. 4(A) — The spool shall be fastened securely to the heelpiece and the heelpiece shall be fastened securely to the base plate. The base plate shall be fastened securely to the mounting strip.

Gauge by feel.

2.23 Tightness of Cover Nut: The cover shall be held securely in place by the cover nut. It shall not be so tight that the cover nut cannot be turned with the thumb and fingers.

Gauge by feel.

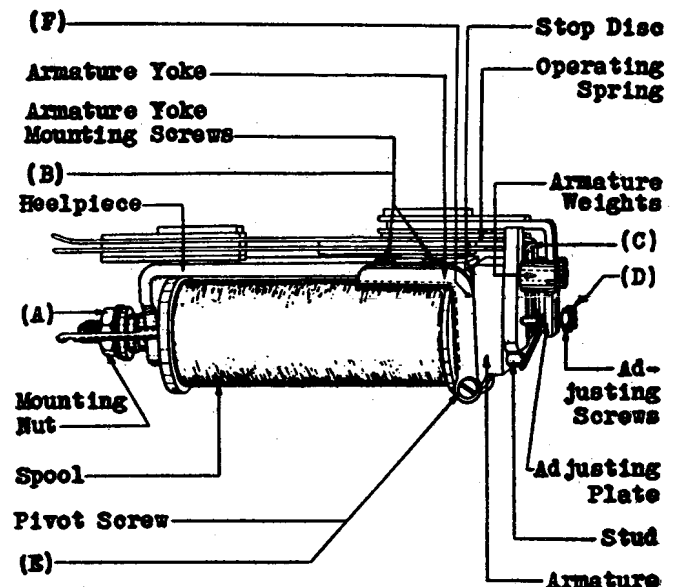

Fig. 4 - 366-type Relay

SECTION 040-821-701

2.24 Tightness of Armature Yoke: Fig. 4(B) —
The armature yoke shall be fastened securely on the heelpiece.

Gauge by feel.

2.25 Separation Between Springs: Fig. 4(C) —
There shall be a clearance between the springs at the upper bend in the springs of

Min. .030"

Gauge by eye.

2.26 Tightness of Adjusting Screws: Fig. 4(D) —
The adjusting screws shall be sufficiently tight to prevent the relay changing its adjustment but shall not be so tight that it is necessary to use undue pressure in turning them.

Gauge by feel.

2.27 Armature Movement: Fig. 4(E) — The armature shall move freely on its pivot screws.

Gauge by feel.

2.28 Clearance Between Armature and Yoke: Fig. 4(F) — The armature shall clear the sides of the armature yoke by

Approx. .010"

Gauge by eye.

2.29 Application of KS-7743 Separators: The KS-7743 separators, when applied in accordance with Section 040-014-811 covering the list of relays on which removable paper separators may be applied, shall be mounted so that the single layer of paper is on the side of the armature next to the core and cover both stop discs.

***2.30 Operated Armature Air Gap:** With the relay in the operated position there shall be a clearance between the armature and the core of

Min. .007"

Max. .013"

Use the No. 74D gauge.

2.31 Stud Gap: The separation between the stud and the operating spring when the relay is operated shall be

Min. .005"

Gauge by feel.

3. ADJUSTING PROCEDURES

3.001 List of Tools, Gauges, and Materials

CODE NO.	DESCRIPTION
TOOLS	
72	5/32" and 3/16" Hex. Double-end Socket Wrench and Screwdriver Combination
102	3/8" Single-end Socket Wrench
259	Spring Adjuster
268	Spring Adjuster
269	Screwdriver
270	Spring Adjuster
422A	90° Offset Screwdriver
423A	45° Offset Screwdriver
—	4-oz. Riveting Hammer
—	6-1/2" P-long-nose Pliers (2 Required)
KS-6854	3-1/2" Screwdriver
—	3" Cabinet Screwdriver
—	4" Regular Screwdriver
—	6" Tweezers
GAUGES	
66D	Thickness Gauge Nest
70D	50-0-50 Gram Gauge
74D	Thickness Gauge Nest
MATERIALS	
KS-7188	Bell Seal Bond Paper, Substance No. 20 — 1/4" by 2-1/2"
KS-7743	Separator (17/64" wide)
KS-7744	Separator (5/8" wide)
KS-7756	Cement
KS-7860	Petroleum Spirits
—	Toothpicks — Hardwood, Flat at One End and Pointed at the Other

Procedures General (All Types of Relays)
(3.01 to 3.08 Incl.)

3.01 Cleaning (Reqt 2.01)

(1) Clean the contacts when necessary in accordance with the section covering cleaning of relay contacts and parts.

(2) Insert a piece of KS-7188 paper between the armature and the core. Withdraw the paper at the same time pressing the armature manually towards the core so that there is a slight pressure between the strip of paper and the parts being cleaned. Repeat the operation until the paper shows no evidence of dirt when it is removed. Use a clean piece of paper for each operation. Take care that the entire surface of the core nearest the armature and the armature is cleaned.

(3) If the pivot screws or armature bearings are dirty, clean them as outlined in (4) and (5).

(4) **All Relays Except 194- and 366-type Relays:** Back off the armature retaining screw with the KS-6854 screwdriver and grasp the armature with the thumb and forefinger, the thumb being placed at the lower end of the armature and the forefinger at the upper right edge. While holding the armature in this position, force it up with the thumb just enough to clear the bearing pins and draw the armature forward until it is free of the relay. Clean the armature bearings, bearing pins, and the nonfreezing discs on the heel-piece with petroleum spirits applied with a clean toothpick to soften the matter, and flush the bearings and pins with petroleum spirits applied with another toothpick. Do not use the same toothpick for more than one operation. After the bearings, pins, and nonfreezing discs are satisfactorily cleaned, grasp the armature as outlined above and tilt it until the back edge of the flat portion of the armature rests on the heel-piece and the flanges clear the bearing pins. Then slide the armature in place, exercising care not to damage the armature studs or the KS-7744 separator when the armature is so equipped. Tighten the retaining screw securely with the KS-6854 screwdriver.

(5) **366-type Relays:** Remove the armature weight in the left side of the armature with the 4" regular screwdriver. Remove the mounting nut with the No. 102 wrench and remove the mounting screws with the KS-6854 screwdriver. Pull the relay forward until the pivot screws are accessible and remove them with the KS-6854 screwdriver. Remove the armature. Take care while doing this not to snag the armature on the operating spring. Clean the pivot screws and the bearings with petroleum spirits applied as outlined in (4). After the parts are satisfactorily cleaned, slide the armature back into place, exercising care not to damage the KS-7743 separator when the armature is so equipped, and insert and securely tighten the pivot screws. Insert and securely tighten the armature weight. Remount the relay on the mounting plate and move the relay back against the mounting plate. Insert and tighten the mounting screws securely. Remount and tighten the mounting nut securely.

(6) If, after cleaning, the armature fails to operate freely, see whether or not there is a satisfactory clearance between the armature and yoke, and if necessary, adjust as outlined in 3.25.

3.02 Contact Alignment (Reqt 2.02)

(1) **194-type Relays:** To align the contacts, adjust the front contact spring with the long-nose pliers at the bend close to the point where it leaves the insulators and spring assembly clamping plate. After making this adjustment, recheck the operated armature air gap.

(2) **366-type Relays:** To align the contacts vertically, remove the armature as outlined in 3.01(5) and adjust the operating spring up or down as required with the No. 268 spring adjuster applied close to the point where the spring leaves the insulators. After aligning the contacts satisfactorily, remount the armature. If the contacts are out of line horizontally, loosen the spring assembly mounting screws with the Nos. 422A and 423A offset screwdrivers as outlined in 3.03 and shift the springs as required.

(3) **All Relays Except 194- and 366-type**

Relays: If the contacts do not line up properly or if the studs or spring stops rub on the springs through which they pass, apply pressure to the ends of the springs close to the contact with the No. 268 spring adjuster. Exercise care not to distort or otherwise damage the springs. If the spring cannot be shifted, loosen the spring assembly mounting screws, using the Nos. 422A and 423A offset screwdrivers or KS-6854 screwdriver as outlined in 3.03, and shift the springs so as to correct the fault. Tighten the mounting screws securely with the screwdrivers.

3.03 Tightness of Assembly (Reqt 2.03)

(1) To tighten loose spring assembly mounting screws, use the Nos. 422A and 423A offset screwdrivers. If the screws cannot be tightened satisfactorily in this manner, remove the relay mounting nut with the No. 102 wrench, the mounting screws with the KS-6854 screwdriver, and remove the relay. Then tighten the assembly mounting screws securely with the KS-6854 screwdriver. Take care when tightening the mounting screws not to destroy the adjustments of the springs. Remount the relay if it was removed to make this adjustment.

3.04 Straightness of Springs (Reqt 2.04)

(1) If the springs are not straight or if the separation between springs is not satisfactory, adjust them as required with the No. 268 spring adjuster applied at the bend.

3.05 Armature Travel (Reqt 2.05)

(1) If the armature travel is not satisfactory, proceed as follows.

(2) **194-type Relays:** To adjust for armature travel on 194-type relays, adjust the back-stop spring just above the point where the armature rests against it with the long-nose pliers.

(3) **All Relays Except 194- and 366-type**

Relays: Remove the armature as outlined in 3.01. To increase the travel, place the armature on a hard solid surface with the ends

of the armature resting on the surface. Then tap the top of the armature lightly with the hammer. To decrease the travel, grasp the horizontal portion of the armature firmly near the flanges with a pair of long-nose pliers and grasp the vertical portion of the armature near the retaining screw with another pair of pliers. Then adjust the armature slightly so as to decrease the distance between the ends of the armature. If the armature is equipped with a KS-7744 separator and it is damaged during adjustment of the armature, replace the separator. Remount the armature as outlined in 3.01 and recheck the adjustment. If it is not satisfactory, repeat the operation. Recheck the residual air gap if the armature is provided with a residual screw.

(4) **366-type Relays:** If the armature travel of relays equipped with lead weights is not satisfactory, give consideration to replacing the armature by an armature equipped with copper armature weights. On all other 366-type relays, change the armature travel by turning the armature adjusting screw in a clockwise or counterclockwise direction with the KS-6854 screwdriver as required. If a satisfactory travel cannot be obtained in this manner, turn the armature adjusting screw in a counterclockwise direction so as to allow the armature to rest against the front contact spring at a point close to the bend in the spring. If the armature travel under this condition does not exceed the specified value, loosen the spring assembly mounting screws slightly with the Nos. 422A and 423A offset screwdrivers and move the springs away from the armature. This will allow a greater armature travel, and conversely moving them toward the armature will decrease the travel. If the spring assembly mounting screws cannot be loosened in this manner, remove the relay as outlined in 3.03. After positioning the springs, turn the armature adjusting screw in a clockwise direction until it just rests against the armature. Recheck the armature travel, and if necessary, position the armature adjusting screw until the proper armature travel is obtained. Check, and if necessary, adjust the contact separation as outlined in 3.07. After the adjustments are satisfactorily made, tighten the spring assembly mounting screws securely.

3.06 Contact Pressure (Reqt 2.06)**3.07 Contact Separation** (Reqt 2.07)

(1) **Contact Pressure:** The requirement for contact pressure should be met at the same time the springs are adjusted to meet the stud gap requirements. In connection with spring tensions that are specified to obtain contact pressure, note that they are specified on an approximate basis. They have, however, a direct bearing on the relay's electrical requirements, and if they are greatly in excess of their approximate tension value, the relay may fail to meet its electrical requirements in which case the tensions may have to be reduced slightly. In readjusting, however, it is desirable to have as much tension as possible on the various springs, consistent with meeting the other requirements. Attempt to distribute the tensions proportionately between the spring combinations and between the light and heavy springs of each combination.

(2) Normally straight springs that have been adjusted should have no sharp bends due to adjustment. A gradual bow is permissible.

(3) When checking the pressures with the No. 70D gauge, the tip of the reed should engage the tip of the spring whose tension is to be measured, holding the gauge in such a position that the reed and spring being measured are practically in a straight line.

(4) Where no definite pressure is specified, tension the springs so that the relay will meet its electrical requirements.

(5) **194-type Relays:** If the pressure of the armature against the backstop is not satisfactory, adjust the armature as required with the No. 259 spring adjuster. To do this, place the adjuster on the armature and slide it back to a position near the rear spoolhead. In making this adjustment, equalize the pressure by adjusting the top and bottom of the armature.

(6) **366-type Relays:** First see that the front contact spring rests against the contact adjusting screw so that when the latter is turned in a counterclockwise direction, the contact end of the spring will follow the screw. With the armature in the operated position, the position of the front contact spring should

be such that the operating spring makes reliable contact with it. If the operating spring fails to make reliable contact in the operated position of the armature, adjust it with the No. 270 spring adjuster as shown in Fig. 5 so that it will rest against the stud with the specified pressure when the armature is in the unoperated position. In making this adjustment, also see that the offset end of the operating spring is at an angle of approximately 35 degrees from a vertical line.

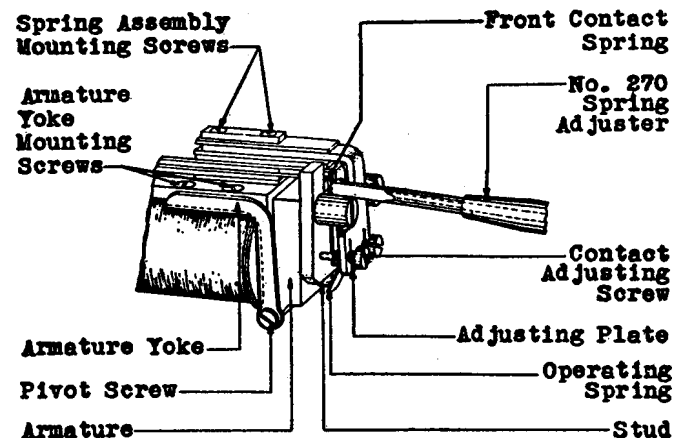

Fig. 5 - Method of Adjusting for Contact Pressure of 366-type Relays

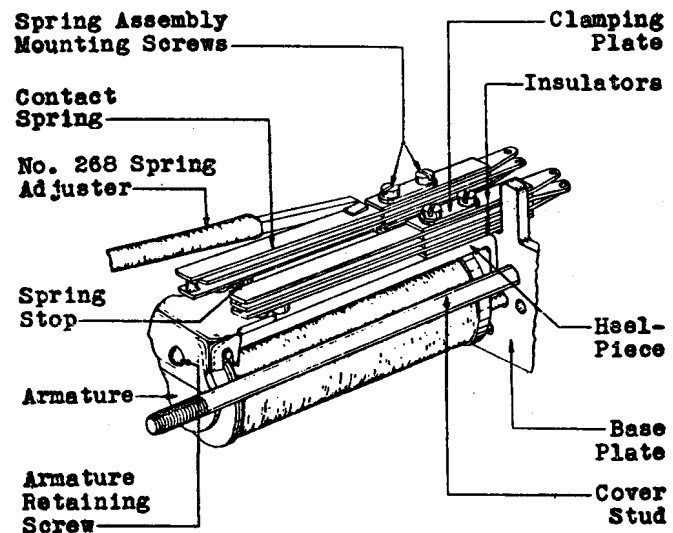

Fig. 6 - Method of Adjusting for Contact Pressure of All Relays Except 194- and 366-type Relays

(7) **All Relays Except 194- and 366-type Relays:** Adjust the spring as required with the No. 268 spring adjuster. Place the adjuster on the front end of the spring but in back of the contacts and armature studs and slide it back to a point about 1/4" from where the spring leaves the spring assembly as shown in Fig. 6. Adjust the spring at this point with a slight twist upward or downward as required, exercising care not to disturb adjacent springs.

Contact Separation

(8) **194-type Relays:** If the contact separation is unsatisfactory, adjust the backstop as required with the long-nose pliers as shown in Fig. 7.

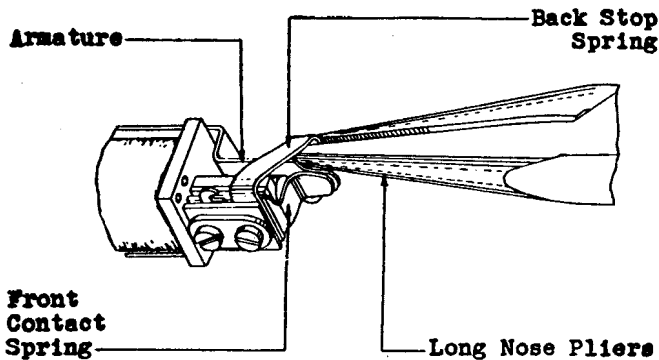

Fig. 7 - Method of Adjusting for Contact Separation of 194-type Relays

(9) **366-type Relays:** If the contact separation is unsatisfactory, turn the contact adjusting screw in a clockwise or counterclockwise direction as required with the KS-6854 screwdriver. If a satisfactory adjustment cannot be obtained in this manner, loosen the spring assembly mounting screws with the Nos. 422A and 423A offset screwdrivers as outlined in 3.03, and shift the contact springs forward to increase the separation and backward to decrease the separation. Then tighten the screws securely.

(10) **All Relays Except 194- and 366-type Relays:** To correct the contact separation, adjust the stationary springs with the No. 268 spring adjuster. Apply the adjuster just in

front of the stud that separates the springs and adjust the spring up or down as required. It is permissible to slightly bow the springs near the contacts in making this adjustment.

3.08 Electrical Requirements (Reqt 2.08)

- (1) If a relay does not meet the electrical requirements, check the spring tensions, and if necessary, increase or decrease them as required.
- (2) If, in the case of the 366-type relay, the armature chatters, check, and if necessary, readjust the armature travel and operated armature air gap.
- (3) **194-type Relays:** If the relay does not operate satisfactorily, reduce the tension of the armature against the backstop as required with the No. 259 spring adjuster. Take care in making this adjustment that the armature rests against the backstop when the relay is unoperated.

Procedures for 194-type Relays (3.09 and 3.10)

3.09 Relay Mounting (Reqt 2.09)

- (1) To tighten relays loose on the mounting strip, tighten the mounting nuts securely with the No. 102 wrench.
- (2) If the armature is not fastened securely to the core, remove the relay mounting nut with the No. 102 wrench and remove the relay from the mounting plate. Then tighten the armature mounting nut securely with the wrench portion of the No. 72 combination wrench and screwdriver. Remount the relay on the mounting strip and remount and tighten the mounting nut securely.

3.10 Operated Armature Air Gap (Reqt 2.10)

- (1) To correct the clearance between the armature and the core, adjust the front contact spring with the long-nose pliers at the bend in the spring close to the point where it leaves the insulators and spring assembly clamping plate. After making this adjustment recheck for contact alignment.

Procedures for 207-, 228-, 244-, 245-, 253-, 257-, 263-, and 285-type Relays (3.11 to 3.18 Incl.)

3.11 Relay Mounting (Reqt 2.11)

- (1) To tighten relays loose on the mounting strip, tighten the mounting nuts securely with the No. 102 wrench.
- (2) If the mounting nuts are tight but the relay is loose on the base plate, tighten the mounting screw securely with the KS-6854 screwdriver. Since the mounting strip and insulator are provided with a hole through which the screwdriver can be applied, it is not necessary to remove the relay from the mounting plate.
- (3) If a relay mounting screw is tight but the spool is loose, remove the relay mounting nut and the relay and tighten the heelpiece mounting nut with the No. 269 screwdriver. Remount the relay and tighten the mounting nut securely.

3.12 Tightness of Cover Nut (Reqt 2.12)

- (1) When remounting a relay cover, slide the cover over the relays so that the cover stud engages the cover nut, and turn the cover nut in a clockwise direction with the fingers until the cover is held securely in place. Three or four turns is all that is necessary to hold the cover in place. Never use a wrench or a pair of pliers to tighten the nut.

3.13 Tightness of Cover (Reqt 2.13)

- (1) If the tightness of the cover on the relay is not satisfactory, pinch the sides of the cover toward each other with the fingers to increase the tightness or pull the sides apart to decrease the tightness.

3.14 Stud and Stop Clearance (Reqt 2.14)

- (1) If the spring stops or studs rub on the springs through which they pass, apply pressure to the ends of the springs with the No. 268 spring adjuster applied near the end of the spring close to the contact. Exercise care not to distort or otherwise damage the springs. If the springs cannot be shifted, loosen the spring assembly mounting screws, using the Nos. 422A and 423A offset screwdrivers or KS-6854 screwdriver as outlined in 3.03,

and shift the springs so as to correct the fault. Tighten the mounting screws securely with the screwdrivers. Take care in making this adjustment that the contacts are not misaligned.

3.15 Separation Between Springs (Reqt 2.15)

- (1) If the springs are not straight or if the separation between springs is not satisfactory, adjust them as required with the No. 268 spring adjuster applied at the bend.

3.16 Tightness of Retaining Screws (Reqt 2.16)

- (1) If the armature retaining screw is loose, tighten it securely with the KS-6854 screwdriver.

3.17 Armature Movement (Reqt 2.17)

- (1) If the armature does not move freely, remove the armature and clean the armature bearings as outlined in 3.01. If, after re-assembling the relay, bind is still present, proceed as follows.

- (2) Remove the armature as outlined in 3.01 and bend the armature flanges slightly with the long-nose pliers. Take care in doing this that each flange is bent approximately the same or the armature will not seat properly. Then remount the armature as outlined in the procedure mentioned above and see that after the adjustment is made the armature rests in the bottom of the slots.

3.18 Application of KS-7744 Separators (Reqt 2.18)

- (1) Remove the armature as outlined in 3.01.
- (2) **Application of Separator Between Armature and Core:** Withdraw a strip of KS-7744 separator paper from the container and cut off a 1/2" piece. Place this separator on a flat surface and with the pointed end of a clean toothpick, which has been dipped approximately 1/8" into KS-7756 cement, distribute a small amount of the cement over an area approximately 1/32" by 3/8" across the 1/2" width near one end. Apply the separator to the inner surface of the armature so that the cemented portion is nearest the armature retaining screw and so that the separator extends from the armature retaining screw to the bottom of the armature as shown in Fig. 8.

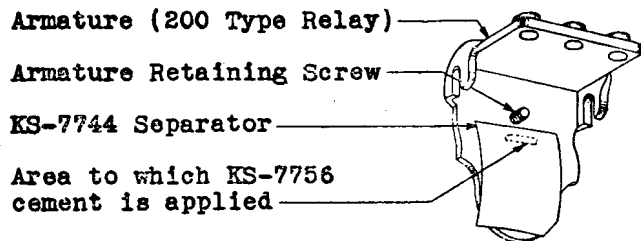

Fig. 8 – Method of Applying KS-7744 Separator

Press down the separator so that it adheres smoothly and tightly to the armature. The corners of the separator which extend beyond the armature may be cut off if desired. Then proceed as outlined in (4) and (5) unless a separator is to be applied to the heelpiece in which case proceed as outlined in (3).

(3) *Application of KS-7744 Separators Between Armature and Stop Discs:* Withdraw a strip of KS-7744 separator paper from the container and cut off a 3/4" piece (slightly shorter than the width of the heelpiece). Dip the pointed end of a clean toothpick approximately 1/8" into the KS-7756 cement and wipe off the excess cement on the inside of the container. The cement remaining on the end of the toothpick should not be sufficient to form a drop. With the point of the toothpick make a line of cement approximately 3/8" back from the front edge of the heelpiece. Apply the cement sparingly as it spreads when the separator is applied to the heelpiece. Place the separator in position so that the rear portion covers both stop discs and the front edge of the separator is approximately 1/16" back of the front edge of the heelpiece and parallel to it. Take care that the separator does not extend beyond the edges of the heelpiece. Using the flat end of the toothpick press the separator so that it adheres firmly to the heelpiece.

(4) After the separator has been applied to the armature or the heelpiece, grasp the armature as outlined in 3.01 and tilt it until the back edge of the flat portion of the armature rests on the heelpiece and the flanges clear the bearing pins. Then slide the armature into position, exercising care not to damage the armature studs. Tighten the armature retaining screw securely with the KS-6854 screwdriver.

(5) Check the mechanical and electrical requirements and readjust if necessary.

3.19 Residual Air Gap (Reqt 2.19)

(1) To change the residual air gap, loosen the residual screw lock nut with the wrench portion of the No. 72 combination wrench and screwdriver and turn the residual screw in a clockwise direction with the screwdriver portion to increase the gap and in a counter-clockwise direction to decrease the gap. After adjusting the residual air gap, tighten the residual screw lock nut securely.

3.20 Stud Gap (Reqt 2.20)

3.21 Contact Follow (Reqt 2.21)

(1) To adjust for a gap between the stud on a spring and the armature, adjust the back contact spring nearest the armature as required. Apply the No. 268 spring adjuster to the spring at a point between the studs and adjust the end of the spring slightly.

(2) In order to obtain a satisfactory stud gap between the stud on the top armature spring and the spring on which is mounted the stud that engages the armature, apply the No. 268 spring adjuster to the top stationary spring and adjust as outlined above.

(3) If the contact follow is insufficient, reduce the contact separation toward the minimum.

(4) After the adjustments are satisfactorily made, check, and if necessary, adjust the springs for contact pressure as outlined in 3.06.

Procedure for 366-type Relays (3.22 to 3.31 Incl.)

3.22 Relay Mounting (Reqt 2.22)

(1) To tighten relays loose on the mounting strip, tighten the mounting nuts securely with the No. 102 wrench.

(2) If the mounting nuts are tight but the relay is loose on the base plate, tighten the mounting screw securely with the KS-6854 screwdriver. Since the mounting strip and insulator are provided with a hole through which the screwdriver can be applied, it is not necessary to remove the relay from the mounting strip.

(3) If a relay mounting screw is tight but the spool is loose, remove the relay mounting nut and the relay and tighten the heelpiece mounting nut with the No. 269 screwdriver. Remount the relay and tighten the mounting nut securely.

3.23 Tightness of Cover Nut (Reqt 2.23)

(1) When remounting a relay cover, slide the cover over the relays so that the cover stud engages the cover nut and turn the cover nut in a clockwise direction with the fingers until the cover is held securely in place. Three or four turns is all that is necessary to hold the cover in place. Never use a wrench or a pair of pliers to tighten the nut.

3.24 Tightness of Armature Yoke (Reqt 2.24)

(1) To tighten loose armature yoke mounting screws, use the Nos. 422A and 423A offset screwdrivers. If the screws cannot be tightened satisfactorily in this manner, remove the relay mounting nut with the No. 102 wrench, the mounting screw with the KS-6854 screwdriver, and remove the relay. Then tighten the mounting screws securely with the KS-6854 screwdriver. Remount the relay if it was removed to make this adjustment.

3.25 Separation Between Springs (Reqt 2.25)

(1) If the springs are not straight or if the separation between springs is not satisfactory, adjust them as required with the No. 268 spring adjuster applied at the bend.

3.26 Tightness of Adjusting Screws (Reqt 2.26)

(1) If the adjusting screws are too tight, remove the screws and widen the slots in the adjusting plate as required with the KS-6854 screwdriver.

(2) If the screws are too loose, remove them with the screwdriver, grasp the sides of the plate near the bottom with the long-nose pliers, and close the slots as required. Reinsert the adjusting screws and turn them to their proper positions.

3.27 Armature Movement (Reqt 2.27)

3.28 Clearance Between Armature and Yoke (Reqt 2.28)

(1) If the armature does not move freely, remove the armature and clean the armature pivots as outlined in 3.01. If, after reassembling the relay, bind is still present, it is probably due to insufficient clearance between the armature and the yokes. To relieve this condition, proceed as follows.

(2) Remove the mounting nut with the No. 102 wrench and the mounting screws with the KS-6854 screwdriver and remove the relay. Then loosen the heelpiece mounting nut with the No. 269 screwdriver. Remove the armature yoke mounting screws with the KS-6854 screwdriver. Remove the armature as outlined in 3.01. While lifting the heelpiece, remove the armature yoke. Adjust the sides of the yoke as required with the long-nose pliers and remount and secure it on the heelpiece. Remount the parts that were removed and remount and secure the relay.

3.29 Application of KS-7743 Separators (Reqt 2.29)

(1) Withdraw a strip of separator KS-7743 from the container and cut off two pieces 15/16" long. Fold over one end of the paper 3/16" long to form a right angle. Insert one of these separators between the armature and core so that the short offset portion extends toward the front of the relay and the long portion covers one of the stop discs as indicated in Fig. 9. The 6" tweezers may be used to facilitate inserting this separator between the armature and core. Apply a small amount of KS-7756 cement to the short end of the separator, using a clean toothpick, and hold the short end of the separator firmly against the top surface of the armature until it adheres. Repeat the above procedures applying the other separator over the other stop disc.

(2) After the separators have been applied, check that the relay meets the electrical and mechanical requirements and readjust if necessary.

3.30 Operated Armature Air Gap (Reqt 2.30)

(1) To check the clearance between the armature and the core, proceed as follows. Remove the mounting nut with the No. 102

wrench and the mounting screw with the KS-6854 screwdriver and remove the relay from the base plate. Remove the spring assembly mounting screws with the KS-6854 screwdriver. Remove the spring assembly from the relay, taking care not to disturb the assembly any more than necessary. With the assembly removed, insert the proper blade of the No. 74D gauge between the armature and core, exercising care that the gauge clears the stop discs, and operate the armature by hand. If the gap is too small, insert the 3" cabinet screwdriver between the armature yoke and the spoolhead, and pry it slightly away from the spoolhead. Do this on both sides of the yoke in order to obtain an even adjustment.

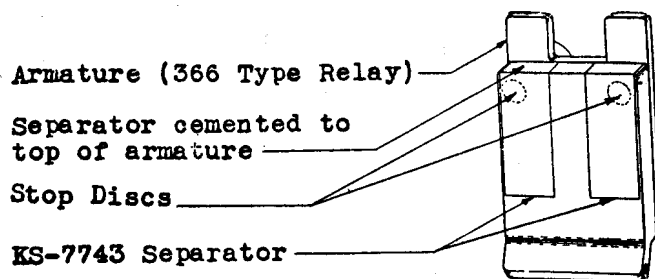

Fig. 9 - Location of KS-7743 Separator on 366-type Relay Armature

(2) If the gap is too large, remove the stud on the left side of the armature with the 4" regular screwdriver, the pivot screws with the

KS-6854 screwdriver, and remove the armature. Then remove the armature yoke mounting screws with the KS-6854 screwdriver and loosen the heelpiece mounting nut with the No. 269 screwdriver. While lifting the heelpiece, remove the armature yoke. With the yoke removed, grasp the end that is normally secured to the heelpiece with the long-nose pliers and the end that is normally secured to the armature with another pair of pliers and bend the ends toward each other slightly. Take care when doing this to obtain an even adjustment on both sides of the heelpiece. Remount and secure the yoke on the heelpiece and remount and secure the armature in place and check the air gap. If the air gap is satisfactory, tighten the mounting nut securely. After the adjustments are satisfactorily made, remount the spring assembly and remount the relay on the base plate and mounting strip. When the specified electrical current is applied to the relay, the armature will not vibrate if the operated armature air gap is satisfactory.

3.31 Stud Gap (Reqt 2.31)

(1) If the gap between the offset end of the operating spring and the stud is not satisfactory when the relay is operated, check the requirements for contact separation and contact pressure, and if necessary, readjust as outlined in 3.06. If the stud gap is still not satisfactory, adjust the offset end of the spring slightly with the No. 270 spring adjuster. Take care when making this adjustment not to disturb any of the other adjustments.