

RELAYS
STROMBERG-CARLSON TYPES
REQUIREMENTS
(CONDENSED SECTION FOR 040-821-701)

1. REQUIREMENTS (Also See Section 020-012-711)

Requirements General (All Types of Relays)

1.01 *Armature Travel*

- (a) Unless otherwise specified use circuit requirement table. 66D gauge.
- (b) Unless otherwise specified, tolerance is Test $+.005''$, $-.0025''$, Readjust $+.0025''$, $-.0025''$.

1.02 *Contact Pressure:* As on figures A to N, consistent with meeting other requirements. Gauge 366 type relays by feel, others with 70D gauge.

1.03 *Contact Separation:* $.007''$. Exception 257A relay $.005''$, 194 type relays per Fig. A $.010''$.

Requirements for 194 Type Relays

1.04 *Operated Armature Air-Gap:* Approx. $.005''$ with relay operated.

Requirements for 207, 228, 244, 245, 253, 257, 263 and 285 Type Relays

1.05 *Stud and Stop Clearance* — Fig. 1 (A): Stud and stops clear springs through which they pass.

1.06 *Armature Movement* — Fig. 1 (B): Move freely in bearings.

1.07 *Stud Gap:* $.005''$ — Separation between armature separator stud and armature stud, or between spring stud and spring, relay unoperated, or between springs and spring stud against which they normally rest, with relay operated.

1.08 *Contact Follow:* Approximately $.005''$ for normally open contacts. Satisfactory if contacts make with relay energized on test or readjust current and $.003''$ gauge (test) $.005''$

(readjust) between armature and core. 66D gauge.

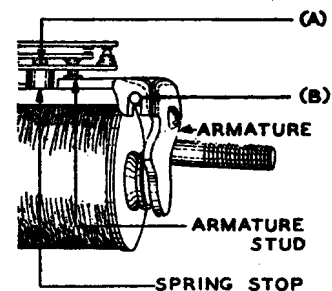

Fig. 1 - 207 Type Relay

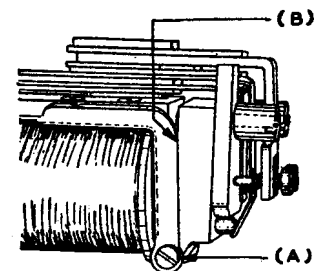

Fig. 2 - 366 Type Relay

Requirements for 366 Type Relays

1.09 *Armature Movement* — Fig. 2 (A): Move freely on its pivot screws.

1.10 *Clearance Between Armature and Yoke* — Fig. 2 (B): Armature to clear sides of yoke approx. $.010''$.

1.11 *Operated Armature Air-Gap:* Min. $.007''$, Max $.013''$ with relay operated. 74D gauge.

1.12 *Stud Gap:* $.005''$ with relay operated.

Variable Requirements for 207, 228, 244, 245, 253,
257, 263 and 285 Type Relays Except Two Com-
binations Specified for 194 and 366 Type Only

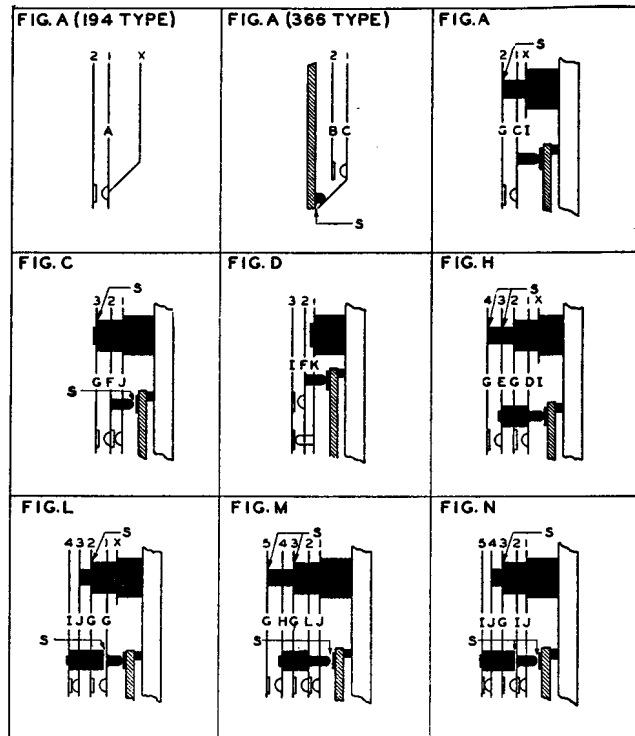

- A = Tension against backstop
- B = Tension against contact adjusting screw
- C = Approx. 15 grams
- D = Approx. 15 grams (spg. 3 removed)
- E = Approx. 15 grams (as stud leaves spg. 1)
- F = Approx. 20 grams
- G = Approx. 30 grams
- H = Approx. 30 grams (as stud leaves spg. 2)
- I = Approx. 40 grams
- J = Approx. 40 grams (armature operated)
- K = Approx. 40 grams (as stud leaves heelpiece, armature operated)
- L = Approx. 40 grams (spg. 4 removed)
- S = Stud Gap — See Rqs. 1.07 and 1.12