

## 197- AND 198-TYPE SWITCHES AND ASSOCIATED BANKS, COMMUTATORS, AND WIPERS CLEANING REQUIREMENTS AND PROCEDURES

### 1. GENERAL

**1.01** This section covers requirements and procedures for cleaning switches, banks, commutators, and wipers.

**1.02** This section is reissued to revise the list of tools, gauges, and materials, to omit the procedures covering checking for loose mechanized bank contacts, to revise the description of KS-16366 filler can, and to revise the methods for pressurizing and checking the KS-16297 L1 flushing unit. Detailed reasons for reissue will be found at the end of the section.

**1.03** Part 2 of this section covers requirements for cleaning, and Part 3 covers the corresponding procedures. Part 4 covers the method of tightening banks, Part 5 the description of tools and materials required, Part 6 the preparation of the tools and materials, Part 7 the checking of the flushing unit, and Part 8 the replacement of flushing unit parts.

**1.04** Previously, specific cleaning intervals were recommended for certain categories of banks, wipers, and commutators. Experience has shown that satisfactory operating results are obtained if banks, wipers, and commutators are cleaned only as required and without regard to the metal of the wiper tip. Factors to be considered in determining whether cleaning is required are covered in 1.05.

#### **1.05** *Indications of Need for Cleaning Bank Contacts and Bank Wipers*

(a) Transmission noise or irregularities in equipment performance may be due to one or more of the following conditions.

(1) Improper wiper adjustment, dirty or worn wiper tips. The condition of the wipers has a direct effect on bank contact reliability.

(2) Troubles in other equipments such as dirty relay or switch jack contacts, poorly filtered talking battery, loose wiring connections, etc.

(3) Dirty or tarnished bank contacts. However, the presence of tarnish, sludge deposits, lint, or other foreign matter on the contacts is not a reliable indication of need for bank cleaning.

Therefore, before assuming that bank cleaning is required, the wipers should be checked to the requirements covered in Section 030-705-704, and the wiper tips examined to determine if the permissible wear described in Section 030-705-704 is exceeded. The wiper springs should be readjusted if necessary, or the wiper assembly replaced if the tips are excessively worn.

(b) If transmission noise or irregularities in equipment performance are not caused by faulty wipers or troubles in other equipment, the banks and bank wipers should be cleaned. In most cases nonabrasive cleaning gives adequate results, although in exceptional cases abrasive cleaning may be required.

(c) A contact noise survey of the office can be made as described in the appropriate sections to check whether the banks and wipers are causing transmission noise.

**1.06** *Nonabrasive cleaning* of bank contacts and separators is performed using the KS-16298 handle and KS-16062 L2 rotor, the rotor being moistened with KS-16436 washing fluid. These tools and materials are described in Part 5.

**1.07** Nonabrasive cleaning can be effective only if the cleaning tools are adequately cleaned through the use of a properly operating KS-16297 L1 flushing unit. Therefore, before

proceeding with nonabrasive cleaning, make sure that the flushing unit is functioning properly as covered in 6.02(b).

**1.08 Abrasive cleaning** is performed using the 402E, 517A, or 517B bank contact cleaner sleeved with 36-type (Aloxite) sleeving. These tools and materials are described in Part 5.

**1.09** If nonabrasive cleaning proves inadequate, abrasive cleaning should be applied in accordance with requirement 2.03 or 2.05.

**1.10 Make-Busy Information:** Before cleaning any banks, make the switch busy in accordance with Section 030-705-701.

#### Definitions.

**1.11 Mechanized banks** are banks in which the contacts are fastened to insulators by means of eyelets. These banks can be identified by the fact that they are held together by three or five hexagon head screws which thread into the lower clamping plate. Mechanized banks may have soldered or solderless (clinched type) connections. All 40-, 41-, 42-, 50-, 51-, 52-, 53-, and 62-type banks and the D-161265 and D-161266 banks are mechanized banks. Coded mechanized banks with a D suffix, for example 40D banks, have soldered connections; those with an E suffix have solderless (clinched type) connections.

**1.12 Nonmechanized banks** are banks in which the contacts are cemented to the insulators. They can be identified by the fact that they are held together by five round head screws which thread into nuts below the lower clamping plate. All nonmechanized banks have soldered connections. All 20-, 21-, 22-, 24-, 25-, 30-, and 31-type banks and the D-156778 banks are non-mechanized banks.

**1.13 Line banks**, for the purpose of this section, are banks having contacts all or part of which are used in talking circuits. **Sleeve banks** are those having contacts used only in signaling circuits. The 30A, 31A, 31B, 50DA, 50EA, 51D, 51E, 51DA, and 51EA banks, for the purpose of this section, are considered as line banks.

**1.14 Silver-plated bank contacts and brass bank contacts**, as covered in this section, should be cleaned when necessary by the same

procedures, including both abrasive and non-abrasive cleaning (see requirement 2.03).

**1.15 A preliminary double stroke** is a rapid stroke back and forth over the first four contacts of the bank level.

#### 1.16 Full Double Stroke

(a) For bank contacts, a full double stroke is one back and forth stroke between the first and last bank contacts of the bank level.

(b) For commutator contacts, a full double stroke is one up and down stroke over all the contacts of the commutator.

(c) For wipers, a full double stroke is one back and forth stroke across both tips of the wiper for the full length of the KS-16365 wiper cleaner.

**1.17 "Fresh" sleeving** is sleeving that has been used for less than 30 full double strokes.

**1.18 "Used" sleeving** is sleeving that has been used for between 30 and 60 full double strokes.

**Note:** Sleeving which is frayed or dirty, or which has been used for more than 60 double strokes should be discarded.

## 2. REQUIREMENTS

### 2.01 Cleaning — All Parts Except Bank Contacts, Separators, Commutator Contacts, and Wipers

(a) **Spring assembly contacts** shall be cleaned when necessary in accordance with Section 069-306-801.

(b) **Shelf jack springs** and their associated plug springs shall be cleaned when transmission or other tests indicate a poor electrical contact between the jack springs.

(c) **Other parts** shall be cleaned when necessary in accordance with approved procedures.

## 2.02 *Nonabrasive Cleaning of Bank Contacts and Separators*

(a) **Before Turnover:** Nonabrasive cleaning shall be applied only if the contacts have previously been abrasively cleaned in accordance with requirement 2.03. In this case, the **After Turnover** requirement (b) shall be applied.

**Note:** Banks shall be cleaned with compressed air as covered in Section 069-503-801 or with the 389A brush.

(b) **After Turnover:** The contacts and separators of these banks and also those of banks in unequipped positions in the same bank multiple shall be nonabrasively cleaned, if necessary, using five preliminary strokes followed by five full double strokes of the KS-16062 L2 rotor moistened with KS-16436 washing fluid.

**Note:** This requirement shall be applied only if necessary to prevent circuit trouble or transmission noise. See 1.05.

## 2.03 *Abrasive Cleaning of Bank Contacts:*

(Does not apply to silver inlay and No. 1 metal inlay contacts. Local records show location of banks having these contacts.)

(a) The bank contacts shall be abrasively cleaned in accordance with Table A using five full double strokes of "used" 36-type (Aloxite) sleeving over three banks followed by five full double strokes of "fresh" 36-type (Aloxite) sleeving over the same banks. Where severe tarnish is present, the number of full double strokes may be increased as required to obtain a satisfactorily cleaned surface.

(b) Following abrasive cleaning as covered in (a), the bank contacts and separators shall be nonabrasively cleaned as covered in requirement 2.02.

**2.04 *Cleaning of Bank Wipers:*** The bank wipers shall be nonabrasively cleaned with KS-16436 washing fluid, using five full double strokes of the KS-16365 wiper cleaner as follows.

(a) Each time the associated bank contacts are cleaned as covered in requirement 2.02(a) or (b).

(b) When a check of wiper tip conditions indicates a need for cleaning. (See 1.05.)

(c) When wipers or individual wiper springs are replaced.

(d) If necessary to make possible an inspection for wiper tip wear. ←

Use the P-220366 dental mirror to check the condition of wipers.

## 2.05 *Cleaning of Commutator Contacts*

(a) **Nonabrasive Cleaning:** Commutator contacts shall be nonabrasively cleaned as follows.

(1) **Before Turnover:** The contacts shall be nonabrasively cleaned using five full double strokes of the KS-16365 wiper cleaner moistened with KS-16436 washing fluid.

(2) **After Turnover:** The contacts shall be nonabrasively cleaned, when necessary, using five full double strokes of the KS-16365 wiper cleaner moistened with KS-16436 washing fluid.

(b) **Abrasive Cleaning:** Commutator contacts shall be abrasively cleaned as covered in the following requirements.

(1) **Before Turnover:** If requested by the telephone company, the contacts shall be abrasively cleaned with ten full double strokes of 36-type (Aloxite) sleeving.

(2) **After Turnover:** The contacts shall be abrasively cleaned with ten full double strokes of 36-type (Aloxite) sleeving if satisfactory circuit performance is not obtained after nonabrasive cleaning.

(3) Following abrasive cleaning as covered in (1) and (2), the commutator contacts shall be nonabrasively cleaned as covered in (a).

**TABLE A — Application of Abrasive Cleaning to Bank Contacts  
(except silver inlay and No. 1 metal inlay contacts)**

BANKS TO BE CLEANED	APPLICATION OF REQUIREMENT	
	BEFORE TURNOVER	AFTER TURNOVER
Line Banks	Only if requested by the telephone company	Only if satisfactory transmission is not obtained after nonabrasive cleaning in accordance with requirement 2.02
Sleeve Banks	No abrasive cleaning	Only if satisfactory circuit operation is not obtained after nonabrasive cleaning in accordance with requirement 2.02

**2.06 Cleaning of Commutator Wipers:** Each time the associated commutator contacts are cleaned as covered in requirement 2.05, and when the commutator wipers are replaced, the wipers shall be nonabrasively cleaned using five full double strokes of the KS-16365 wiper cleaner moistened with KS-16436 washing fluid.

### 3. CLEANING PROCEDURES

#### 3.001 List of Tools, Gauges, and Materials

CODE OR SPEC NO.	DESCRIPTION	CODE OR SPEC NO.	DESCRIPTION
<b>TOOLS</b>			
33	11/32-Inch Hex. Single-End Socket Wrench	555A	3/16-Inch Hex. Single-End Socket Wrench
46	3/8-Inch Hex. Single-End Socket Wrench	670A	Double-End Screwdriver
245	3/8- and 7/16-Inch Open Double-End Flat Wrench	KS-6320	Orange Stick
→269	Screwdriver	KS-6854	Screwdriver
373D	Contact Burnisher Holder	KS-7782 (2 reqd)	Parallel Jaw Pliers
374A (modified)	Contact Burnisher Blade (see 6.06)	KS-8237	5/16-Inch Ratchet Socket Wrench Equipped With Detail 3
376A	Dental Mirror	KS-14164	Brush
389A	Brush	KS-14761	Portable Lamp
402E	Bank Contact Cleaner	KS-16297 L1	Flushing Unit
418A	5/16- and 7/32-Inch Open Double-End Flat Wrench	KS-16298	Handle
517A	Bank Contact Cleaner	KS-16366	Filler Can
517B	Bank Contact Cleaner	R-1021	1/2-Inch Flat Brush
541A	1/4-Inch 12-Point Double-End Box Wrench	R-1770	1/2- and 9/16-Inch Open Double-End Flat Wrench
		P-220366	Dental Mirror
		—	B Scissors
		—	Combination Pliers
		—	3-Inch C Screwdriver
		—	4-Inch E Screwdriver
		—	5-Inch E Screwdriver
		—	P-Long-Nose Pliers
		<b>GAUGES</b>	
		79F	0-6000 Push-Pull Gram Gauge
		or	
		R-2771	0-6 Pound Spring Balance

CODE OR SPEC NO.	DESCRIPTION
<b>MATERIALS</b>	
36A	Sleeving
36B	Sleeving
KS-2423	Cloth
KS-6824	Sealing Compound
KS-7860	Petroleum Spirits
KS-16062 L2	Rotor
KS-16365	Wiper Cleaner
KS-16436	Washing Fluid
P-170145	Washer (for use with 517B bank contact cleaners)
—	Aluminum Oxide Abrasive Cloth, 150 grade
—	6-Ply Twine
—	Toothpicks, Hardwood, Flat at One End and Pointed at the Other
—	Soap Solution

**3.002 Cleaning Banks Located Adjacent to a Commutator:** When cleaning banks located adjacent to a commutator, take care not to damage the commutator wiper terminal. In some cases it may be advisable to bend the commutator wiper terminal forward slightly to increase the clearance for inserting the bank cleaner. After cleaning, it will not be necessary to bend the terminal back again.

**3.003 Check for Loose Nonmechanized Bank Contacts:** After cleaning the bank contacts of nonmechanized banks as covered in the following procedures, observe whether any contacts have shifted from their original position as a result of the cleaning operations. If any contacts have shifted, restore them to their correct position, using the KS-6320 orange stick, taking care that these contacts do not cross other contacts at the wiring ends. Then proceed as covered in 4.03 through 4.07 to tighten the bank clamping screws.

**3.004 Preventing Concentration of Fumes:** It is desirable to prevent concentration of fumes resulting from evaporation of the KS-16436 washing fluid during nonabrasive cleaning of banks and wipers. To do this, locate

an electric fan so that it will direct a current of air toward the freshly cleaned switch parts and the KS-16297 L1 flushing unit. In cases where the switchroom air is brought in through a central circulating system, it is advisable to temporarily set the air controls to provide a higher than normal percentage of outside air.

**3.01 Cleaning — All Parts Except Bank Contacts, Separators, Commutator Contacts, and Wipers (Reqt 2.01)**

(1) **Spring Assembly Contacts:** Clean the contacts in accordance with Section 069-306-801.

(2) **Shelf Jack Springs:** To clean the shelf jack springs and their associated plug contacts, remove the switch from the frame as covered in Section 030-705-701. Remove all loose dirt from the jack springs and plug contacts with the 389A brush. Then clean the contacting surfaces of the jack springs and plug contacts with aluminum oxide abrasive cloth, 150 grade cloth. Exercise care to prevent dust and loose particles from being deposited on other apparatus.

(3) **Switches:** Dust and loose particles may ordinarily be removed by brushing with an R-1021 brush. If, upon inspection, there is found to be an accumulation of gummy oil or foreign matter on the vertical or rotary ratchets, or other parts of the switch, clean the parts with a KS-2423 cloth rolled as covered in 6.01 and dipped in KS-7860 petroleum spirits. Clean with the end of the roll having the shorter fold. When the cloth becomes soiled, refold it as covered in 6.01 to present a fresh surface for cleaning.

(4) **Lubrication:** After cleaning lubricated parts with KS-7860 petroleum spirits, allow the switch mechanism to dry and then re-lubricate the parts in accordance with Section 030-705-706.

**3.02 Nonabrasive Cleaning of Bank Contacts and Separators (Reqt 2.02)**

**General**

(1) When starting with a clean, dry rotor, moisten the rotor with KS-16436 washing fluid as covered in 6.04(a).

(2) Flush the rotor as covered in 6.04(b) after cleaning the banks on the following number of switches.

Two 4-bank switches or  
three 3-bank switches or  
five 2-bank switches or  
ten 1-bank switches

Flushing of the rotor after cleaning the banks on the number of switches recommended above will maintain the rotor in a satisfactory condition. After cleaning approximately 200 banks, the rotor discs will become worn to the point where the rotor should be replaced. Generally, this wear cannot be detected by visual inspection. Dispose of used rotors in accordance with local instructions.

### 197-Type Switches — Bank Associated With One Wiper

#### (3) *Cleaning Upper Half of Bank*

(a) Clean the upper half of the bank with the switch shaft in the vertical normal position. Hold the KS-16298 handle so that the associated KS-16062 L2 rotor is at the right with the discs horizontal and extending toward the bank to be cleaned. Position the rotor at the left of the bank so that the discs will enter the five upper levels of the bank with the top level between the second and third discs from the top of the rotor. When cleaning the upper half of banks in the top position on switches having a channel-type stiffening bracket, shown in Fig. 1, place the rotor in the bank with the top level between the first and second discs

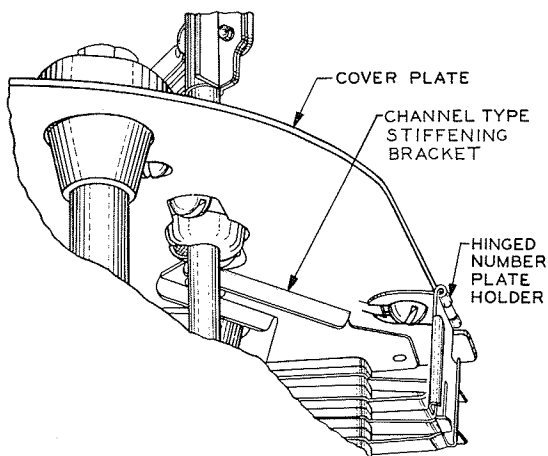

Fig. 1 — Channel-Type Stiffening Bracket on Coverplate

from the top of the rotor. This will prevent interference of the bracket with the rotor.

(b) Roll the rotor discs across the contacts, maintaining just sufficient pressure toward the bank to keep the discs between the bank levels and to insure that they engage the full depth of the bank contacts. Take care to keep the discs horizontal as they rotate across the bank contacts. While making a full stroke, be sure that the discs engage the last contacts at the right side of the bank but limit the movement of the rotor to prevent the discs from leaving the bank. Do not exert upward or downward pressure against the bank contacts. Use the number of strokes covered in the requirement. Fig. 2

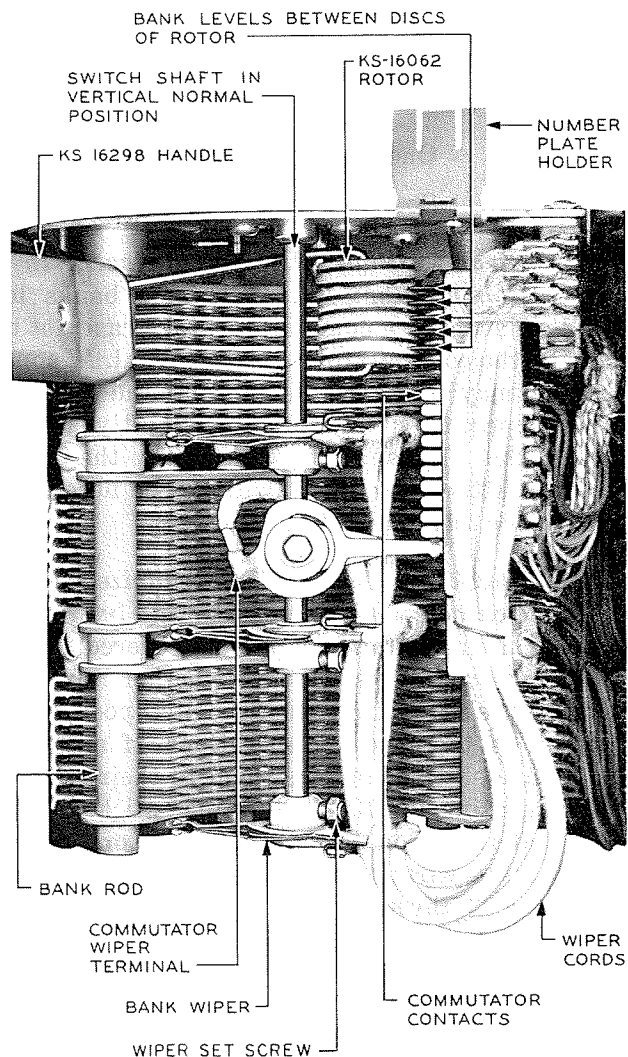

Fig. 2 — KS-16062 Rotor at Right End of Upper Half of Bank

shows the rotor at the right end of half of a full double stroke over the upper five levels of a bank.

**Caution:** *When placing the rotor of the cleaner in a bank adjacent to a commutator, take care not to damage the commutator wiper terminal. In some cases it may be advisable to bend the commutator wiper terminal forward slightly to increase the clearance for inserting the rotor discs. Avoid unnecessary contact between the discs and the wiper cords.*

(4) **Cleaning Lower Half of Bank:** To clean the lower half of the bank, proceed as follows. Raise the shaft so that the wipers are above the levels to be cleaned. Hold the KS-16298 handle so that the associated KS-16062 L2 rotor is at the right with the discs horizontal and extending toward the bank to be cleaned. Position the rotor at the left of the bank so that the discs will enter the five lower levels of the bank with the bottom level between the second and third discs from the bottom of the rotor. Then proceed as covered in (3) (b).

(5) **Checking for Loose Nonmechanized Bank Contacts:** Check for loose nonmechanized bank contacts as covered in 3.003.

#### 197-Type Switches — Banks Associated With Two Wipers

(6) **Cleaning Upper Half of Bank:** Loosen the upper wiper with the 3-inch C screwdriver or the 555A wrench and move it downward against the lower wiper. Clean the upper half of the bank as described in (3).

(7) **Cleaning Lower Half of Bank:** Loosen both wipers with the 3-inch C screwdriver or the 555A wrench and raise them above the middle of the bank. Temporarily secure them in this position and clean the lower half of the bank as covered in (4).

(8) **Positioning Wipers:** Position the wipers to meet the requirements covered in Section 030-705-704 and tighten the clamping screws securely.

(9) **Checking for Loose Nonmechanized Bank Contacts:** Check for loose nonmechanized bank contacts as covered in 3.003.

#### 198-Type Switches

(10) **Cleaning Individual Bank Levels:** Clean each level provided on the banks as follows.

(a) Step the shaft to the eighth rotary position. Hold the KS-16298 handle so that the associated KS-16062 L2 rotor is at the right with the rotor horizontal and extending toward the level to be cleaned. Position the rotor at the left of the level to be cleaned so that the discs will enter the bank with this level between the third and fourth discs from the top of the rotor.

(b) Roll the rotor discs across the first six contacts, maintaining just sufficient pressure toward the bank to keep the discs between the bank levels and to insure that they engage the full depth of the bank contacts. Take care to keep the discs horizontal as they rotate across the bank contacts. Limit the movement to the first six contacts to prevent the discs from snagging on the wiper. Do not exert upward or downward pressure against the bank contacts. Use the number of strokes covered in the requirement.

(c) Restore the switch to normal and step the shaft to the fourth rotary position. Insert the rotor from the right side of the bank with the rotor to the left of the handle so that the level to be cleaned is between the third and fourth discs from the top of the rotor. Roll the rotor discs across contacts 10 to 7, following procedures similar to those covered in (b). Restore the switch to normal.

#### 3.03 Abrasive Cleaning of Bank Contacts (Req't 2.03)

##### General

(1) For cleaning banks on 197-type switches as covered in (3) through (9), use the proper tool, in accordance with Table B, sleeved with 36A or 36B (Aloxite) sleeving as covered in 6.05.

(2) For cleaning banks on 198-type switches as covered in (10) through (14), use the 517B bank contact cleaner modified as described in 5.08(4) and sleeved with 36B (Aloxite) sleeving as described in 6.05.

TABLE B

TOOL TO BE USED	FOR BANKS HAVING	NOTES
402E with 36A sleeving	200 points	Except banks located opposite a commutator
517A with 36B sleeving	200 points	Only for banks located opposite a commutator. Bank cleaner should have P-462665 blade support (short blade support).
517B with 36B sleeving	100 points	

#### 197-Type Switches — Banks Associated With one Wiper

(3) **Cleaning Upper Half of Bank:** With the blade support clamped on the handle of the proper bank contact cleaner so that it is above the cleaning blades, hold the cleaner with the blades horizontal and their concave sides to the right. Place the cleaner in front of the bank with the top blade above the top level. Enter the bank from the left side to a position behind the switch shaft. Make sure that a blade of the bank contact cleaner is between the blade support and the bank contacts. Press the cleaner firmly in against the bank and work the handle horizontally so that the sleeved blades sweep across the contacts with a maximum sweep. Maintain the pressure against the bank throughout the specified number of full double strokes to prevent the blades from snagging on the right end of the bank insulators.

(4) **Cleaning Lower Half of Bank:** Raise the shaft so that the wipers are above the levels to be cleaned. With the blade support clamped on the handle of the bank contact cleaner so that it is below the cleaning blades, hold the cleaner with the blades horizontal and their concave sides to the right. Place the cleaner in front of the bank with the bottom blade below the bottom level. Enter the bank from the left side to a position behind the switch shaft. Make sure that a blade of the

bank contact cleaner is between the blade support and the bank contact. Press the cleaner firmly in against the bank and work the handle horizontally so that the sleeved blades sweep across the contact with a maximum sweep. Maintain the pressure against the bank throughout the specified number of full double strokes to prevent the blades from snagging on the bank insulators.

- (5) **Checking for Loose Nonmechanized Bank Contacts:** Check for loose nonmechanized bank contacts as covered in 3.003.

#### 197-Type Switches — Banks Associated With Two Wipers

(6) **Cleaning Upper Half of Bank:** Loosen the upper wiper with the 3-inch C-screwdriver or the 555A wrench and move it downward against the lower wiper. Clean the upper half of the bank as covered in (3).

(7) **Cleaning Lower Half of Bank:** Loosen both wipers with the 3-inch C screwdriver or the 555A wrench and raise them above the middle of the bank. Temporarily secure them in this position and clean the lower half of the bank as covered in (4).

(8) **Positioning Wipers:** Position the wipers to meet the requirements covered in Section 030-705-704 and tighten the clamping screws securely.

- (9) **Checking for Loose Nonmechanized Bank Contacts:** Check for loose nonmechanized bank contacts as covered in 3.003.

#### 198-Type Switches

(10) Loosen the wipers, using the 3-inch C screwdriver or the 555A wrench, and shift them on the shaft until the cleaner can be inserted into the bank at the level to be cleaned.

(11) **Cleaning Top of Each Level:** Hold the 517B cleaner, modified as covered in 5.08(4), with the blades horizontal and their concave sides to the right. Place the cleaner in front of the bank so that the bottom blade is resting on the top surface of the bank level, the top blade acting as a stiffener for the bottom one. Enter the bank from the left side and press the cleaner in against the bank. While applying downward pressure on the cleaner,



work the handle horizontally so that the sleeved blade sweeps across the contacts with a maximum sweep. Maintain the pressure against the bank throughout the specified number of full double strokes.

(12) **Cleaning Bottom of Each Level:** Hold the cleaner with the blades horizontal with their concave side to the right. Place the cleaner in front of the bank so that the top blade is pressed against the bottom surface of the level, the bottom blade acting as a stiffener for the top one. Enter the bank from the left side and press the cleaner firmly in against the bank. While applying upward pressure on the cleaner, work the handle horizontally so that the sleeved blade sweeps across the contacts with a maximum sweep. Maintain the pressure against the bank throughout the specified number of full double strokes.

(13) **Positioning Wipers:** Position the wipers to meet the requirements covered in Section 030-705-704 and tighten the clamping screws securely.

(14) **Checking for Loose Nonmechanized Bank Contacts:** Check for loose nonmechanized bank contacts as covered in 3.003.

- |      |   |
|------|---|
| 3.04 | <b>Cleaning of Bank Wipers</b> (Reqt 2.04)            |
| 3.05 | <b>Cleaning of Commutator Contacts</b><br>(Reqt 2.05) |
| 3.06 | <b>Cleaning of Commutator Wipers</b><br>(Reqt 2.06)   |

#### **Nonabrasive Cleaning of Wipers and Commutator Contacts**

##### **General**

- (1) Nonabrasively clean the wipers and commutator contacts using KS-16436 washing fluid.
- (2) Before starting cleaning and after cleaning the wipers and commutator contacts of three switches, flush the KS-16365 wiper cleaner with KS-16436 washing fluid.
- (3) To flush the KS-16365 wiper cleaner, proceed as follows. Hold the wiper cleaner under the nozzle of the KS-16297 L1 flushing unit and press the valve operating lever downward to open the valve. Flush both sides of the cleaner until the liquid in the trough ap-

pears clear. Then blot excess liquid from the cleaner on the drying pad of the KS-16297 L1 flushing unit. Discard the cleaner after cleaning approximately 200 wipers or commutators.

##### **Bank Wipers**

(4) With the switch at rotary normal, clean the bank wipers by inserting the KS-16365 wiper cleaner between the wiper tips with the beveled side away from the switch shaft. Draw the cleaner back and forth between the wiper tips for the specified number of full double strokes while exerting slight pressure against both tips with the fingers.

##### **Commutator Contacts and Commutator Wipers**

(5) Flush and moisten the KS-16365 wiper cleaner as covered in (3). Clean commutator contacts as covered in (6) and commutator wipers as covered in (7).

(6) **Commutator Contacts:** To clean commutator contacts, step the switch to the fourth rotary position. Holding the KS-16365 wiper cleaner with the beveled side away from the commutator clamping plate, press the cleaner against the commutator as shown in Fig. 3. Then rub the cleaner up and down over the commutator contacts the specified number of full double strokes.

(7) **Commutator Wiper:** To clean the commutator wiper, restore the switch to normal and then step it to the third rotary position. Hold the KS-16365 wiper cleaner against the contacting surface of the wiper lightly with the fingers. Rub the cleaner up and down across the contacting surface for the specified number of full double strokes.

##### **Abrasive Cleaning of Commutator Contacts**

(8) With a 374A contact burnisher blade, modified as covered in 6.06 and securely clamped in the 373D contact burnisher holder, sleeve the blade with 36A sleeving as covered in 6.06. Step the switch to the fourth rotary position and abrasively clean the commutator contacts as covered in (9) and (10).

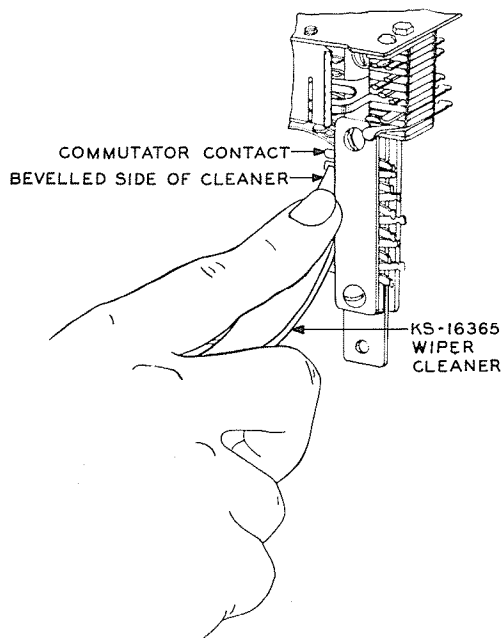

**Fig. 3 – Method of Nonabrasively Cleaning Commutator Contacts**

(9) Holding the contact burnisher holder in the hand, press the offset portion of the sleeved blade against the commutator contacts with the forefinger. Rub the sleeved blade up and down over the commutator contacts for the specified number of full double strokes. When the sleeving becomes dirty, shift the sleeving to provide a clean surface by moving it further up and folding it back on the blade. After one side of the sleeving becomes dirty, remove the sleeving from the blade, turn it over, and push it fully on the blade. Use the clean side of the sleeving as covered above.

(10) After abrasively cleaning the commutator contacts, nonabrasively clean them as covered in (5) and (6).

#### 4. TIGHTENING BANKS

##### Mechanized Banks

**4.01** Tighten the bank clamping screws to minimum 16, maximum 18 pound-inches torque. Tighten the screws successively to obtain an approximately even distribution of pressure on the clamping plate. To check the torque, apply the 541A wrench on the head of the clamping screw and insert the hook of the R-2771 spring balance in the hole at the free end of the

wrench as shown in Fig. 4. If this check is made with the switch mounted on the shelf, take care that the wrench does not slip from the head of the screw during the tightening operation since this might cause damage to the wipers or the shaft. A pull of 4-1/2 to 5 pounds (in the direction to tighten the screw) without moving the screw is an indication that the screw has been satisfactorily tightened. A 79F gauge may be used instead of the R-2771 spring balance. In this case, loop a piece of 6-ply twine through the hole at the free end of the wrench and apply the gauge to this loop. A pull of 2050 to 2275 grams (in the direction to tighten the screw) without moving the screw indicates that the screw has been satisfactorily tightened.

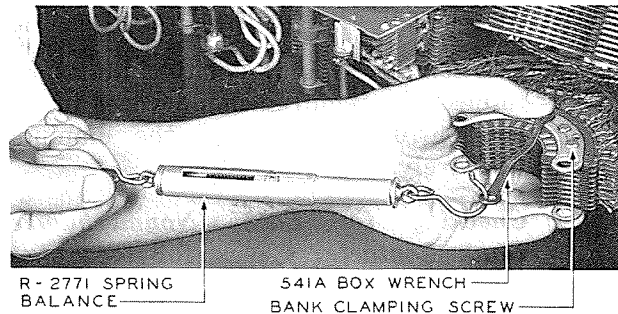

**Fig. 4 – Method of Checking Tightness of Bank Clamping Screws on Mechanized Bank**

**4.02** Check for the bank and wiper requirements covered in Section 030-705-704. Especially check that the wipers cut in properly at each level. When certain line finders are made busy, raising and rotating the shaft manually may result in a resistance battery being placed on a bank contact by the wipers. Where this condition may occur, insulate the proper contacts of the vertical off-normal spring assembly to remove this condition from the wipers.

##### Nonmechanized Banks

**4.03** After loose bank contacts have been aligned as covered in 3.003, proceed as follows. Raise the shaft one step. Remove the loose nuts one at a time. Dip the KS-14164 brush into KS-6824 sealing compound and apply a small amount of the compound to the threads of the nuts. Immediately remount the nut.

**4.04** Tighten the nuts sufficiently to hold them securely in position using the 418A or KS-8237 wrench. To do this, start with the center nut and alternately tighten the nuts at each end of the bank. Check the tightness of nuts as covered in 4.07. If the clamping screw turns while tightening the nut, proceed as covered in 4.05.

**4.05** Turn the screw to permit the insertion of one of the blades of a 670A screwdriver. Insert the large end marked L of the screwdriver in the slot of the bank clamping screw. If this end of the screwdriver does not fit because the slot in the head of the screw is too narrow, use the small end marked S. Hold the screwdriver until the nut grabs and then allow the screwdriver to move with the screw until the screwdriver rests against the bank rod. Where the spacing between banks is such that the 670A screwdriver cannot be inserted into the slot of a bank clamping screw, it will be necessary to lower the bank slightly as covered in 4.06.

**Caution:** Do not wedge the screwdriver between the head of the bank clamping screw and the bank clamping nut of the bank above, since this may cause bending of the upper bank clamp and deformation of the bank.

Then, while holding the bank clamping screw as covered above, turn the bank clamping nuts with the 418A wrench starting at the center screw. Alternately tighten the nuts at each end of the bank to maintain approximately equal pressure on the screws. About one-quarter to one-half turn of the nut after it is seated against the bank is usually sufficient to hold the bank contacts in position.

**4.06 Lowering Banks:** To lower a bank, loosen the bank rod collar clamping screws with the 3-inch C screwdriver or 555A wrench, rotate the collars toward the front of the switch, and lower the bank slightly. After lowering the bank, tighten the bank rod collar clamping screws sufficiently to prevent the bank from sliding off the bank rods. Seal and tighten the bank clamping nuts securely as covered in 4.03, 4.04, and 4.05. Raise the bank into position and tighten the bank rod collar clamping screws. After tightening the bank, check for the alignment of the wipers with the bank contacts as covered in Section 030-705-704.

**4.07 Check for Tightness of Nuts:** To check whether the nuts are satisfactorily tightened, apply the 418A or KS-8237 wrench in connection with an R-2771 spring balance or a 79F gauge as follows.

(1) If the R-2771 spring balance is used, apply the hook 3/8 inch from the free end of the 418A wrench or 2 inches back of the free end of the KS-8237 wrench. If the 79F gauge is used, tie the hook end of the gauge to the 418A or KS-8237 wrench with a piece of 6-ply twine as shown in Fig. 5. Hold the wrench in position on the nut and gradually pull the gauge at right angles to the shank of the wrench as shown in Fig. 5 (in the direction to tighten the screw), until the reading of the R-2771 spring balance is 4 to 4-1/2 pounds. If the 79F gauge is used, the reading should be between 1800 and 2050 grams. Take care that the wrench does not slip from the bank clamping nut during the tightening operation since this might damage the wipers or the shaft.

(2) Again check that the bank contacts are properly aligned and tight, using the KS-6320 orange stick and the 376A dental mirror. If the bank contacts are still loose, open the bank and recement the terminals in their correct position as covered in Section 030-705-806.

(3) Check for the bank and wiper requirements covered in Section 030-705-704. Especially check that the wipers cut in properly at each level. When certain line finders are made busy, raising and rotating the shaft manually may result in a resistance battery

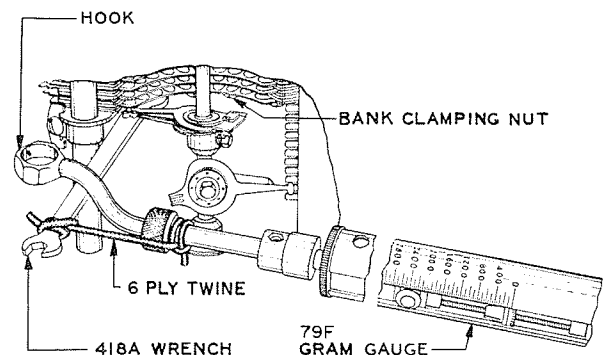

**Fig. 5 – Method of Checking for Tightness of Bank Clamping Nuts on Nonmechanized Banks Using 418A Wrench and 79F Gram Gauge**

being placed on a bank contact by the wipers. Where this condition may occur, insulate the proper contacts of the vertical off-normal spring assembly to remove this condition from the wipers.

## 5. DESCRIPTION OF TOOLS AND MATERIALS

### Tools and Materials for Nonabrasive Cleaning

5.01 The tools and materials listed below are used for nonabrasive cleaning.

KS-16062 L2 Rotor mounted in the  
KS-16298 Handle  
KS-16297 L1 Flushing Unit  
KS-16365 Wiper Cleaner  
KS-16366 Filler Can  
KS-16436 Washing Fluid

These tools and materials are briefly described in the following paragraphs.

### 5.02 *KS-16062 L2 Rotor and KS-16298 Handle:*

The KS-16062 L2 rotor mounted in the KS-16298 handle is used to nonabrasively clean bank contacts and separators. The rotor is made up of seven laminated discs held together by a hollow spindle which also serves as the rotor bearing. Each disc is faced on both sides with a nylon pile fabric having flexible bristles.

### 5.03 *KS-16297 L1 Flushing Unit:*

The KS-16297 L1 flushing unit, shown in Fig. 6, is provided to flush and apply KS-16436 washing fluid to the rotor discs of the bank cleaner.

(1) The flushing unit contains two receptacles, one for used and the other for fresh KS-16436 washing fluid. The tank of the unit serves as the receptacle for used liquid. Fresh liquid is poured into the can fastened to the underside of the cover of the unit. The can fits in the tank when the cover is in place on the tank.

(2) The cover of the unit has an inclined trough with a comb of eight wires extending the length of the trough. At the upper end of the trough the manifold nozzle feeds fresh liquid, under pressure, to the rotor discs being flushed when the associated valve is opened by pressing the rotor discs against the valve operating plate. The valve can also be opened manually by depressing the lever on

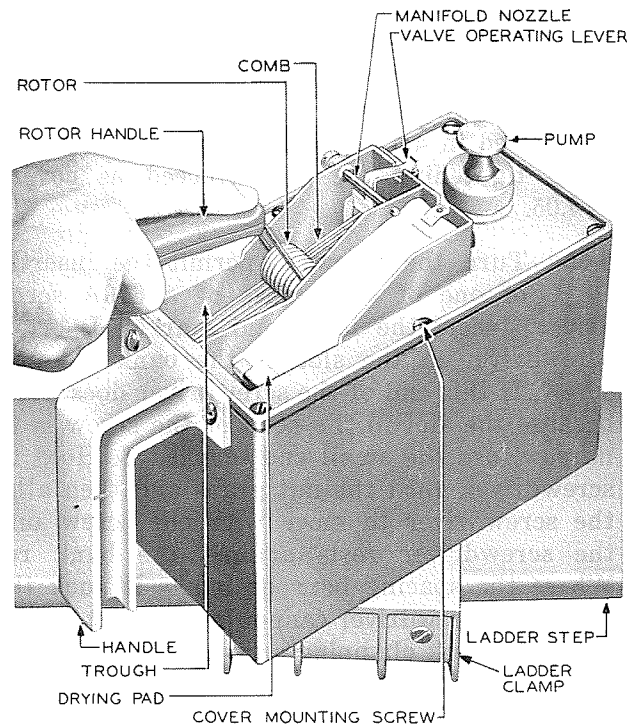

Fig. 6 – Method of Flushing KS-16062 L2 Rotor Using KS-16297 L1 Flushing Unit

the operating plate to flush the KS-16365 wiper cleaner used for cleaning wipers and commutator contacts. A coil spring on the lower part of the valve plunger holds the valve closed and the valve operating plate in its normal position. At the lower end of the trough are several holes for draining used liquid into the tank.

(3) The fresh liquid passes through a filter before entering the manifold nozzle. The filter is held in a retainer which screws against the flared end of the nozzle and holds the nozzle in position. The cap screw shown in Fig. 7 closes the access hole to the filter and nozzle.

(4) Adjacent to the flushing trough is the drying pad for removing excess liquid from the rotor discs after flushing. This pad should be replaced after approximately 25,000 banks have been cleaned. Replacement is recommended after this use because of wear and clogging of the pad, which reduces its absorbent properties.

(5) The fresh liquid is put under pressure by the pump mounted on the cover of the unit and extending into the can containing the fluid.

(6) The flushing unit is filled with fresh liquid by removing the pump and pouring the liquid from the KS-16366 filler can. Used liquid is drained from the tank by removing the drain plug in the opposite end of the tank from the handle.

(7) The flushing unit is mounted on a U-shaped spring clamp to hold the unit to the step of a ladder as shown in Fig. 6. A swivel joint is provided between the unit and the clamp so that the unit may be positioned on the ladder step as desired. The bottom of the clamp serves as a base when the flushing unit is placed on a flat surface. The unit is also equipped with a handle at one end.

**5.04 KS-16366 Filler Can:** The KS-16366 filler can is used to fill the KS-16297 L1 flushing unit with fresh KS-16436 washing fluid. Never use the can to flush the cleaning tools or drain the used liquid as sediment left in the can when it is used to fill the unit may be carried into the clean fluid can and cause clogging of the nozzle openings, fluid filter, or other fluid passages. When not in use, the filler can should be protected against dust and lint.

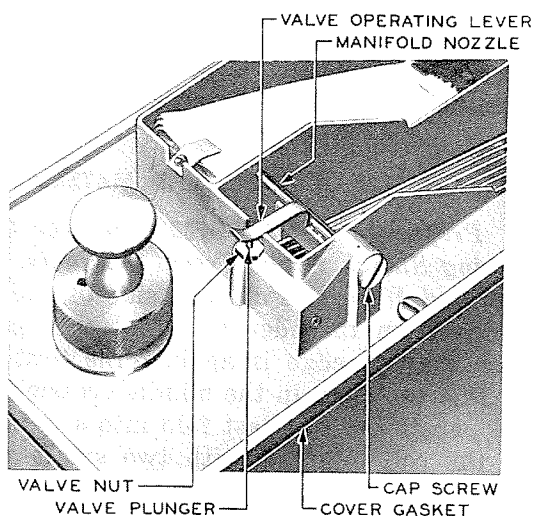

**Fig. 7 – Partial View of KS-16297 L1 Flushing Unit Showing Manifold Nozzle and Associated Parts**

**5.05 KS-16365 Wiper Cleaner:** This cleaner is used for nonabrasive cleaning of bank and commutator contacts and wipers. It consists of a strip of double-faced nylon pile fabric about 2-1/2 inches long, beveled at each end. The cleaner is moistened with KS-16436 washing fluid from the KS-16297 L1 flushing unit preparatory to its use.

**5.06 KS-16436 Washing Fluid:** This liquid contains a small percentage of oil and is used for nonabrasive cleaning of bank and commutator contacts and wipers.

#### **Tools and Materials for Abrasive Cleaning**

**5.07** The tools and materials listed below are used for abrasive cleaning.

402- and 517-Type Bank Contact Cleaners  
373D Contact Burnisher Holder and Modified 374A Contact Burnisher Blade  
36A and 36B Sleeving

These tools and materials are briefly described in 5.08 through 5.10.

**5.08 402- and 517-Type Bank Contact Cleaners:** The 402- and 517-type bank contact cleaners are used to abrasively clean line and sleeve switch banks. They are described in detail below.

(1) The 402- and 517-type bank contact cleaners consist essentially of a handle approximately 5 inches long, six flexible notched blades which fit into six slots at one end of the handle, and a rigid sleeved blade support. A screw extends through the slots in the handle, the upper notches in the blades, and the blade support if it is used. A thumb nut clamps these parts firmly together as shown in Fig. 8.

(2) The blade support is used to support the adjacent cleaning blade so that sufficient pressure can be exerted to properly clean the contacts of the top and bottom levels of a bank. The blade support can be located either under the screw or thumb nut so that it is above the top cleaning blade when cleaning the contacts of the top level, or below the bottom cleaning blade when cleaning the contacts of the bottom level. The blade support is anchored on a pin which protrudes about 1/16 inch from each side of the handle to

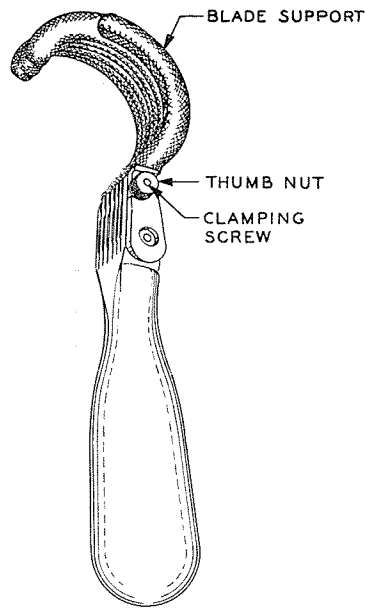

Fig. 8 - 517A Bank Contact Cleaner

prevent movement of the support during the cleaning operation.

(3) The following table shows the essential differences between the 402- and 517-type bank cleaners.

CODE OF CLEANER	ARC OF CLEANER BLADES	BLADE THICKNESS	FOR CLEANING BANKS HAVING	NOTES
402E	Small	0.021	200 points	1
517A	Large	0.021	200 points	1,2
517B	Large	0.045	100 points	

**Note 1:** The 402E bank contact cleaner is used for cleaning all 200-point banks except those located opposite a commutator. The 517A bank contact cleaner is used only for cleaning 200-point banks located opposite a commutator.

**Note 2:** Use P-462665 short blade support shown in Fig. 10.

(4) For cleaning banks on 198-type switches, all but two blades of the 517B cleaner are removed as shown in Fig. 9. P-170145 washers supplied with the cleaner are then inserted in the spaces left blank by the removed blades, permitting the remaining blades to be clamped in the handle of the cleaner.

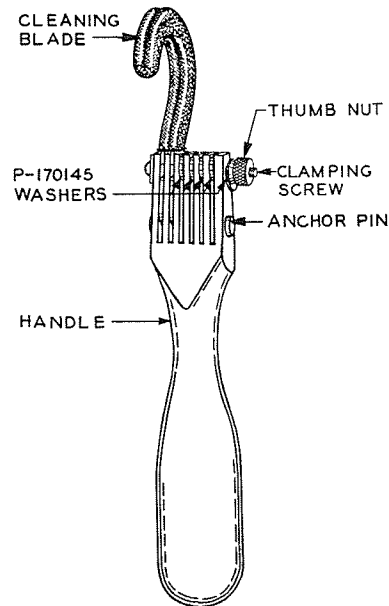

Fig. 9 - 517B Bank Cleaner Arranged for Cleaning Top Level of Banks on 198-Type Switches

**5.09 373D Contact Burnisher Holder and Modified 374A Contact Burnisher Blade:** The 374A contact burnisher blade modified in accordance with 6.06, sleeved with 36A sleeving, and mounted in a 373D contact burnisher holder is used for cleaning commutator contacts.

**5.10 36-Type (Aloxite) Sleeving:** 36-type (Aloxite) sleeving is precut to proper length for use on 402- and 517-type bank cleaners. 36A sleeving is for use on 402E bank cleaners, and 36B sleeving is for use on 517A or 517B cleaner. It is supplied as dry sleeving in cans containing 700 pieces of sleeving.

## 6. PREPARATION OF TOOLS AND MATERIALS

**6.01 Preparation of KS-2423 Cloth for Cleaning Switch Parts Except Contacts, Separators, and Wipers:** Fold one side of the cloth  $\frac{3}{4}$  inch from the edge and fold the opposite side so that its edge is against the first edge. Then fold the cloth in the middle crosswise and roll it parallel to this last fold into a tight roll. Hold the roll together with two small rubber bands, one at each end of the roll. When the end of the cloth becomes soiled, unfold the cloth and refold it to present a new surface for cleaning. To do this, fold the end which initially had the short ( $\frac{3}{4}$  inch) fold approximately 1- $\frac{1}{4}$  inches

from the edge, and again fold the opposite side so that its edge is against the first edge. Fold, roll, and fasten as before. As new cleaning surfaces are required, proceed as before, placing the new fold in each case 1/2 inch further in from the edge than the previous one.

#### Tools and Materials for Nonabrasive Cleaning

##### 6.02 *KS-16297 L1 Flushing Unit and KS-16366*

**Filler Can:** The KS-16297 L1 flushing unit is used to moisten and clean the discs on the KS-16062 L2 rotor. For use the unit should be filled, pressurized, and positioned as covered in (a) through (c). When necessary, used or unused KS-16436 washing fluid may be drained as covered in (d).

**Caution:** *The flushing unit should be drained and filled outside the switchroom in a location specified locally for this purpose. Not more than 1 gallon of KS-16436 washing fluid should be kept in the switchroom at one time.*

(a) **Filling:** Fill the KS-16366 filler can with KS-16436 washing fluid. Unscrew and remove the pump from the flushing unit. Pour the washing fluid from the filler can into the unit until the liquid starts to rise in the filler tube in the unit. Remount and tighten the pump on the unit. To prevent spillage when remounting the pump, slightly tilt the flushing unit toward the handle.

(b) **Pressurizing:** With the flushing unit filled as covered in (a), about a dozen strokes of the pump should provide sufficient pressure for 2 hours of normal use without repressurizing. It may then be necessary to add pressure by taking a few additional strokes with the pump. When the plunger of the valve assembly, shown in Fig. 13, is depressed, five streams of washing fluid should be discharged from the nozzle. If more frequent repressurizing of the flushing unit is necessary or if other operating defects are noted, determine the cause of the trouble as covered in Part 7. Refer to Part 8 for parts replacement information.

(c) **Positioning:** Place the flushing unit in a position convenient to the banks which are to be cleaned. If a ladder is to be used, mount the unit on a step by forcing the clamp

at the bottom of the unit as far as possible over the step.

(d) **Draining:** Drain used or unused KS-16436 washing fluid from the unit as covered in (1) and (2), respectively.

**Note:** If the unit is not to be used for several days, drain the used liquid as covered in (1).

##### (1) *Draining Used KS-16436 Washing*

**Fluid:** Shake the unit to loosen sediment from the bottom of the tank, taking care not to spill any liquid from the drain holes in the trough. Then remove the drain plug and drain the used liquid into a suitable container. Do not use the filler can for this purpose. Remount and securely tighten the drain plug. Discard the used liquid in the approved manner.

##### (2) *Draining Unused KS-16436 Washing*

**Fluid:** Unscrew the pump and pour as much liquid as possible from the flushing unit into a suitable container. Then remount and tighten the pump. Pressurize the pump by taking approximately 12 strokes with the pump. Then depress the valve operating arm to discharge liquid through the nozzle. While discharging the liquid, rock the unit in order to leave as little liquid as possible at the bottom. Alternately pressurize the unit and discharge liquid in this way until only air is discharged from the nozzle.

##### 6.03 *Method of Mounting KS-16062 L2 Rotor on KS-16298 Handle:*

To mount the KS-16062 L2 rotor on the KS-16298 handle, spread the prongs in the handle apart and insert them in the spindle of the rotor.

##### 6.04 *Method of Moistening and Flushing KS-16062 L2 Rotor*

(a) **Moistening Rotor:** With the flushing unit filled, pressurized, and positioned as covered in 6.02(a) through (c), moisten the clean, dry rotor as follows.

(1) Position the rotor in the trough of the flushing unit so that six wires of the comb are sandwiched between the discs of the rotor and the remaining wires are against the outer surfaces of the end discs as shown in Fig. 6. Roll the rotor to the

upper end of the trough against the valve operating plate, thus opening the valve, and saturate the rotor with KS-16436 washing fluid.

(2) While maintaining pressure against the trough, roll the rotor back and forth three or four times without opening the valve. This removes some of the excess liquid from the rotor. Remove the rotor from the trough and roll it three or four times over the adjacent drying pad to further remove excess liquid. Press the rotor against the pad during this operation.

(b) **Flushing Rotor:** With the flushing unit filled, pressurized, and positioned as covered in 6.02(a) through (c), flush the rotor as follows.

(1) Position the rotor in the trough of the flushing unit so that six wires of the comb are sandwiched between the discs of the rotor, and the remaining wires are against the outer surfaces of the end discs as shown in Fig. 6. Roll the rotor to the upper end of the trough against the valve operating plate, thus opening the valve, and flush the rotor with KS-16436 washing fluid.

(2) While maintaining pressure against the trough, roll the rotor back and forth, making sure that it is saturated with liquid at the upper end of every third or fourth stroke. These operations remove the sludge and debris from the discs. When the liquid in the trough appears clear, roll the rotor back and forth three or four times without opening the valve. This removes some of the excess liquid from the rotor. Remove the rotor from the trough and roll it three or four times over the adjacent drying pad to further remove excess liquid. Press the rotor against the pad during this operation.

#### Tools and Materials for Abrasive Cleaning

**6.05 Method of Resleeving 402- and 517-Type Bank Cleaners:** To resleeve a 402- or 517-type bank cleaner, proceed as follows.

(1) Loosen the thumb nut. Remove the blade support by forcing it backward so that the slot in the support is free of the thumb nut. Then force the blades backward until the

upper slot is free from the screw in the handle as shown in Fig. 10, and remove the blades from the handle.

(2) Remove the sleeving from each pair of blades by grasping the sleeving at the inner end and working it toward the tip of the blade. At the same time, lift it alternately toward the inner and outer edges of the blade to disengage the sleeving from the notches on the blade.

(3) Resleeve the blades in pairs as shown in Fig. 11. Use 36A sleeving for sleeving the 402E cleaner and 36B sleeving for sleeving the 517A or 517B cleaner. Both the 36A and 36B sleeveings are cut to the correct length for these cleaners.

(4) Push the clean sleeving over the blade so that it is held securely by the notches in the blade. Then pull the sleeving toward the tip of the blade to stretch it tightly on the blade. Push the other end of the sleeving over the other blade of the pair in a similar manner. Make sure that the sleeving is equally distributed on each blade and that the tips of the blades, when in the position shown in Fig. 11, are in contact. Then fold each pair of blades together as shown in Fig. 12. Insert them in the handle from the rear (the code number of the tool is on the front of the handle), so that the slots in the lower ends of the blades engage the anchor pin. Swing the blades forward until the ends of the upper slots in the blades are in contact with the screw in the handle. Make sure that the sleeving is taut.

(5) Remount the blade support with the anchor pin engaging the hole in the end of the support. Then force the support forward under the thumb nut or screwhead as far as the slot will permit. The blade support tapers slightly. Thus, if the thumb nut or screwhead is set so that the open end of the slot of the support will just go under it, the act of forcing the support forward will wedge it between the nut or screwhead and the handle.

**6.06 Preparation of 374A Burnisher Blade for Cleaning Commutator Contacts:** Modify a 374A contact burnisher blade as follows for cleaning commutator contacts. Grasp the blade about 1/2 inch from either end with the KS-7782 pliers held across the blade, and then grasp the



blade about 1/4 inch from the same end with another pair of KS-7782 pliers held parallel to the length of the blade. Bend the short end of the blade to an angle of about 45 degrees to give an offset about 3/8 inch long. Clamp the blade

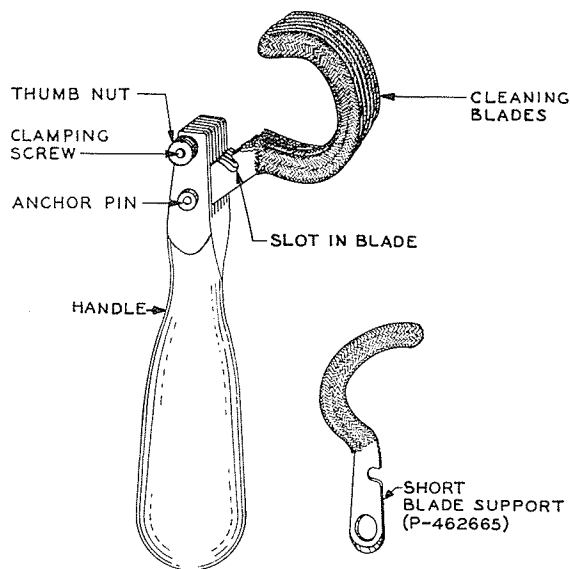

Fig. 10 – Method of Removing Blades From Bank Cleaners

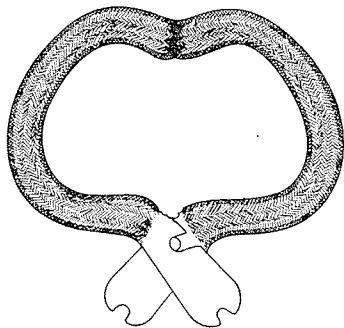

Fig. 11 – Pair of Sleeved Blades — Unfolded

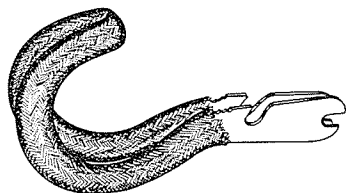

Fig. 12 – Pair of Sleeved Blades — Folded

firmly in the 373D contact burnisher holder. Cut off a piece of 36A or 36B sleeving about 3 inches long, using the B scissors, thread it over the full length of the blade, and fold the free end of the sleeving back over the blade.

## 7. CHECKING KS-16297 L1 FLUSHING UNIT

**7.01 Checking Operation of KS-16297 L1 Flushing Unit:** To check that the KS-16297 L1 flushing unit is functioning properly, proceed as follows.

(a) Fill the unit with KS-16436 washing fluid as covered in 6.02(a). Make sure that the pump cap is tightened against the top of the filler tube in the cover of the unit. Then apply 12 full strokes of the pump to pressurize the unit. Check that the plunger of the pump does not rise when it is released and that no fluid is dripping from the nozzle. Allow the unit to stand unused for about 2 hours, after which depress the valve operating plate to depress the valve assembly plunger. Five streams of washing fluid should be discharged from the openings in the manifold nozzle. When the pressure is removed from the valve operating plate, the flow of fluid should be promptly stopped.

(b) If the unit does not function as covered in (a), trouble may be due to one or more of the following conditions. To check for possible cause, proceed as covered in 7.02 through 7.05.

- (1) Defective or sticking pump check valve.
- (2) Leakage between pump cap and filler tube.
- (3) Defective or sticking fluid release valve.
- (4) Clogged nozzle openings, fluid filter, or other fluid passages.
- (5) Defective seal between bottom of clean fluid can and head of can mounting bolt.
- (6) Defective can gasket between top of clean fluid can and flushing unit cover.

**7.02 Checking for Defective Pump Check Valve:** If the pump piston rises after pressurizing the unit or if there is no pressure, this may be caused by a defective pump check

valve. See 8.12 for method of replacing the pump valve. Loss of pressure may also be caused by other defects as covered in 7.03 through 7.05.

**7.03 Checking for Leakage Between Pump Cap and Filler Tube:** Make sure that the pump cap is screwed down tightly against the top of the filler tube, and pressurize the unit. Apply soap solution around the lower edges of the pump cap to determine whether air leakage occurs around the filler tube. Leakage may be caused by a defective gasket or by inability to force the pump down against the gasket as the pump cap is screwed down due to defective threads on the neck of the filler tube. Unscrew the cap and remove the pump. If the gasket is defective, replace it. If the threads on the neck of the filler tube are defective, the flushing unit shall be returned to the Western Electric Company for corrective action.

**7.04 Checking for Faulty Fluid Discharge:**

If the fluid discharge system does not function properly as the fluid release valve is depressed and released, this may be due to clogged nozzle openings, a clogged filter, or a defective fluid release valve. Relieve the pressure in the unit by loosening the pump, then retighten the pump and proceed as follows. Remove the cap screw in the filter mounting and remove the filter retainer using the 269 screwdriver. Remove the dirt from the filter with a toothpick. If necessary, remove the manifold nozzle by withdrawing it through the filter housing. Check the intake hole of the nozzle, remove dirt from around it, and flush with clean KS-7860 petroleum spirits. If the nozzle holes are clogged and it is not possible to remove the obstruction, replace the nozzle as covered in 8.05. Remount the filter and cap screw. If the fluid discharge is still faulty, the fluid release valve may be defective. In this case, determine whether the valve assembly is the earlier or later type, as covered in 8.14. If the valve assembly is the earlier type, replace it as covered in 8.13. If the valve assembly is the later type, remove it and replace parts as required as covered in Part 8.

**7.05 Defective Can Gasket or Seal:** To determine whether air leakage occurs at the head of the fluid can mounting bolt or between the top of the clean fluid can and flushing unit

cover, remove the cover mounting screws with the 4-inch E screwdriver and lift the cover and can assembly from the tank. Pressurize the clean fluid can. Then invert the can and apply soap solution around the head of the can mounting bolt and check for air leakage at this point; bubbles indicate leakage. Then turn the can so that any washing fluid inside the can will be away from the point being checked and apply soap solution along the gasket between the can and cover. If air leakage occurs, tighten the can mounting bolt with the R-1770 wrench and recheck for air leaks. If this does not correct the condition, install a new lead washer under the brass washer at the head of the can mounting bolt and tighten the bolt. If there is still air leakage, install an additional lead washer as the depression in the bottom of the can may be too deep to permit one lead washer to give a good seal. If air leakage occurs between the top of the clean fluid can and flushing unit cover, replace the can gasket as covered in 8.18.

**8. REPLACEMENT OF KS-16297 L1 FLUSHING UNIT PARTS**

**ORDERING INFORMATION**

**8.01** Ordering information for parts of the flushing unit that can be replaced in the field is given in Fig. 13, 14, and 15. The part numbers are given in the figures with the names of the parts as listed by the Western Electric Merchandise Department. Where these names differ from those in general use, the latter names, in some cases, are shown in parentheses.

**8.02** Information enclosed by parentheses is not ordering information. This information may be references to notes, parts referred to in other portions of the section and not considered replaceable, or part names in general use in the field if these names differ from those assigned by the manufacturer.

**8.03** When ordering parts for replacement purposes, give the KS and list number with the name of the part, for example: KS-16297 L9 Pump Assembly. No attempt should be made to replace parts not designated. Do not refer to the BSP number or to any information shown in parentheses or in notes following the part number.

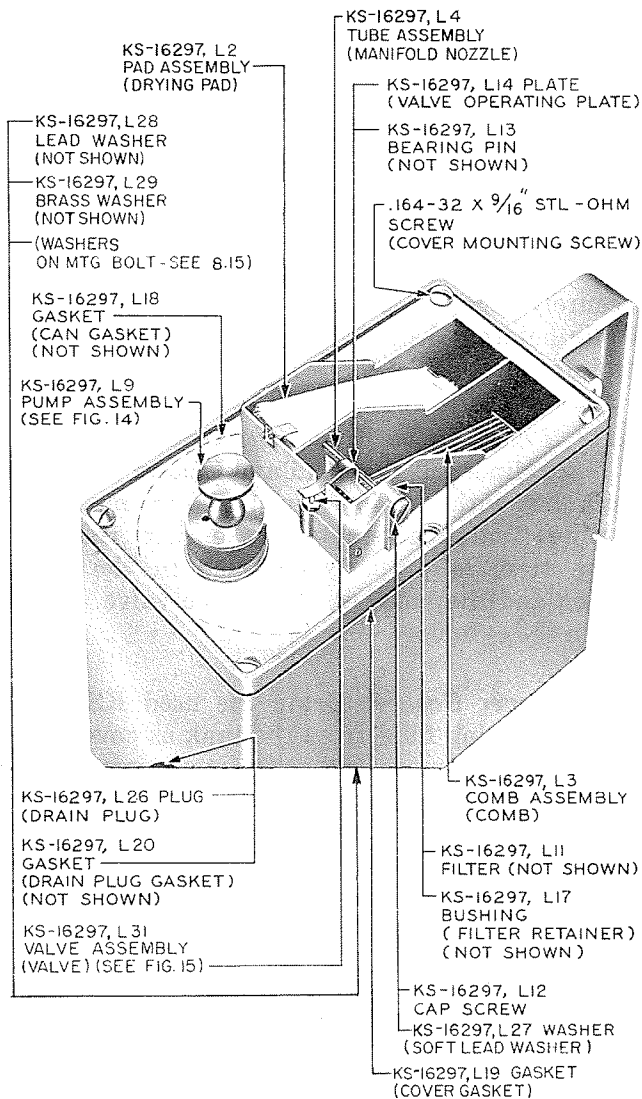

**Fig. 13 – Replaceable Parts of KS-16297 L1 Flushing Unit**

**REPLACEMENT PROCEDURES**

**General**

**8.04** Before replacing any part on the flushing unit, loosen the pump to relieve the pressure.

**Filter, Filter Retainer, and Manifold Nozzle**

**8.05** To replace the filter, retainer, or nozzle, remove the cap screw using the 4-inch E screwdriver. Remove the filter retainer using the 269 screwdriver. If the filter is not being replaced, remove foreign particles with a toothpick. If the filter is to be replaced, push it out of the retainer with a toothpick. Insert the new

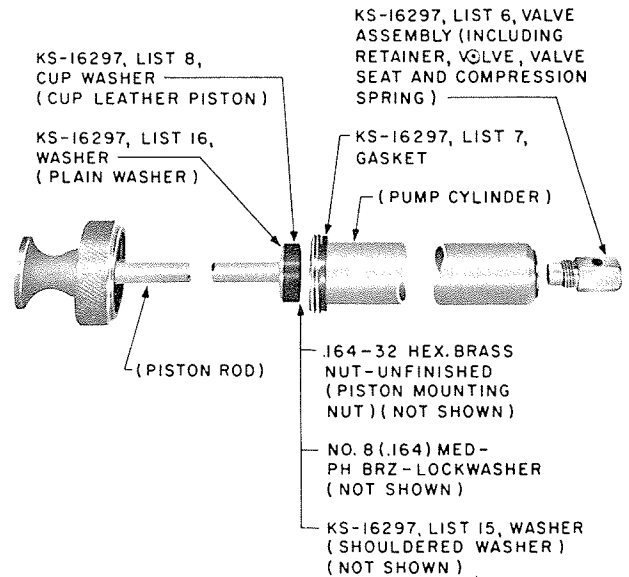

**Fig. 14 – Replaceable Parts of KS-16297 L9 Pump Assembly**

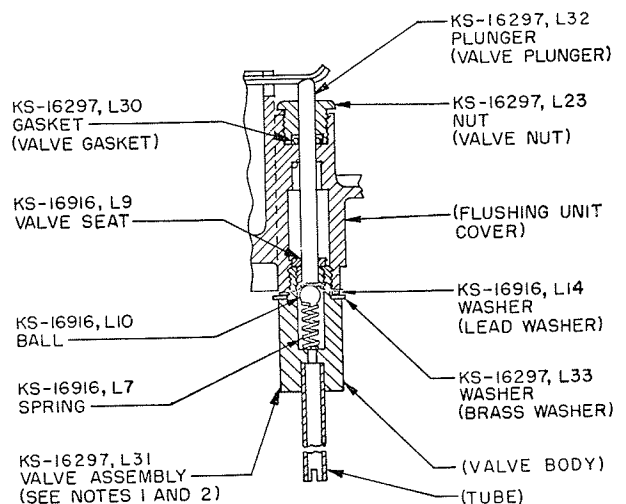

**NOTES:**

1. THE KS-16297, L31 VALVE ASSEMBLY INCLUDES THE KS-16916, L9 VALVE SEAT, KS-16916, L10 BALL, KS-16916, L7 SPRING, KS-16916, L32 PLUNGER, VALVE BODY AND TUBE.
2. IF THE KS-16297, L31 VALVE ASSEMBLY IS REMOVED FROM THE COVER, REPLACE THE KS-16916, L14 LEAD WASHER.

**Fig. 15 – Cross-Section Showing Replaceable Parts Associated With the KS-16297 L31 Valve Assembly**

filter, convex side outward, and push it into the retainer. Make sure that the filter is seated against the inner surface of the retainer. When properly seated, the filter will be approximately

flat. If the nozzle is to be replaced, push it through the housing. Insert the new nozzle through the housing, with the holes at the bottom. Then, while holding the nozzle with the fingers, screw the filter retainer against the end of the nozzle. Using the 376A dental mirror, check that the holes of the nozzle are at the bottom after tightening the retainer. Remount and securely tighten the cap screw.

#### Comb, Valve Operating Plate, and Bearing Pin

**8.06** To replace these parts, first loosen the two comb mounting screws approximately three full turns using the KS-6854 screwdriver. Slide the comb toward the handle until the large diameter portion of the comb mounting holes is under the screw heads. Remove the comb, valve operating plate, and bearing pin. Substitute new parts as required and mount the parts in the reverse order of removal.

#### Valve Nut and Gasket (Fig. 15)

**8.07** Remove the manifold nozzle as covered in 8.05. Swing the valve operating plate backward so that the lever on the plate clears the valve nut. Remove the valve nut, using the 245 wrench. Substitute parts as required, using the KS-6320 orange stick to remove the valve gasket from the nut. Mount the parts in reverse order of removal.

#### Pump Assembly

**8.08** To replace any part of the pump (Fig. 14), unscrew the cap and remove the pump from the flushing unit cover. After replacing parts as necessary, mount the pump on the cover and tighten it securely.

**8.09 Pump Gasket:** Fig. 15 — Unscrew the pump cylinder from the cap sufficiently to permit the gasket to be removed from the cylinder. Place the new gasket in position against the shoulder of the cylinder and securely tighten the cylinder in the cap.

**8.10 Cup Leather Piston and Washers:** Fig. 15 — Unscrew the cap and remove the cup leather piston from the cylinder. To avoid marring the piston rod, fold eight thicknesses of KS-2423 cloth around the rod, grasp the rod with the combination pliers over the cloth, and remove the piston mounting nut and lockwasher, using the 33 wrench. Remove the

cup leather piston and associated shouldered washer. Substitute new parts as necessary. Place the shouldered washer in the cup leather piston so that the projecting portion of the washer extends through the hole in the piston. Position the plain washer against the shoulder on the rod and the cup leather piston with its shouldered washer against the plain washer. Place the lockwasher against the shouldered washer. Securely tighten the nut with the 33 wrench while holding the rod with the pliers and cloth as before.

**8.11 Pump Valve Assembly:** Grasp the pump cylinder in the hand and remove the valve assembly with the 46 wrench. Before mounting the new valve assembly, make sure that the valve stem is properly inserted in the valve spring and the housing. Mount the valve assembly in the cylinder.

**8.12 Cover Gasket:** Drain the used KS-16436 washing fluid from the tank as covered in 6.02(d)(1). Remove the cover mounting screws with the 4-inch E screwdriver. Lift the cover from the tank. Remove the cover gasket. Substitute the new gasket, making sure it is properly seated in the recess in the cover, and mount the parts in reverse order of removal.

#### Valve Assembly, Valve Assembly Parts, and Can Gasket

**8.13** The valve assembly initially furnished has a valve body  $3/16$  inch long which mounts against the underside of the cover. If this assembly or any of its parts require replacement, replace the complete assembly with the KS-16297 L31 valve assembly subsequently introduced which has a  $7/8$ -inch long valve body and is shown in Fig. 15.

**8.14** The valve plunger of the KS-16297 L31 valve assembly may be replaced as an individual part without removing the cover. If the plunger can be removed, substitute the new plunger, inserting it in the valve so that the spherical end is outward. Check the valve gasket and replace if necessary. Mount the parts in the reverse order of removal. If the plunger cannot be removed, the valve is of the earlier design, which must be replaced as covered in 8.13.

**8.15** Before replacing the can gasket, valve assembly, or any valve assembly part except the plunger of the KS-16297 L31 valve assembly (see 8.13), drain the used liquid from the tank as covered in 6.02(d)(1) and the unused liquid from the can as covered in 6.02(d)(2). Then remove the cover as covered in (1) and the can as covered in (2).

(1) Remove the cover mounting screws with the 4-inch E screwdriver. Lift the cover from the tank. Check the cover gasket and if it is torn or otherwise damaged, substitute a new gasket making sure that it is properly seated in the recess in the cover.

(2) Remove the can mounting bolt with the R-1770 wrench and remove the can. Check the can gasket and if it is torn or otherwise damaged, substitute a new gasket, making sure that it is properly seated in the recess in the cover. When remounting the can, make sure that the brass washer is adjacent to the head of the mounting bolt and that the lead washer is between the washer and the can. After replacing parts as required, mount the parts in reverse order of removal.

**8.16 Valve Assembly:** Fig. 15 — After following the procedures covered in 8.15, unscrew the valve assembly from the inside of the cover using the 245 wrench applied to the hexagonal section. Remove the brass and lead washers from the valve assembly and replace the lead washer. Position the brass and lead washers on the new valve assembly. Remove the old plunger from the cover using the P-long-nose pliers. Insert the new plunger from the inside of the cover, spherical end first. Mount the new

valve assembly and the washers, tightening the hexagonal section securely. Remove the valve nut on the outside of the cover as covered in 8.07 and replace the valve gasket if necessary.

**8.17 Valve Seat, Spring, and Ball:** After following the procedures covered in 8.15, remove the valve assembly except the plunger as covered in 8.16. Replace the lead washer. Remove the valve seat using the 5-inch E screwdriver. Substitute new parts as required.

**8.18 Can Gasket:** After following the procedures covered in 8.15, substitute the new gasket making sure that it is properly seated in the recess in the cover.

#### REASONS FOR REISSUE

1. To add a paragraph covering maintenance of tools used for nonabrasive cleaning [1.06(b)].
2. To add a requirement for cleaning of bank wipers [2.04(d)].
3. To revise the list of Tools, Gauges, and Materials (3.001).
4. To omit the information for checking loose mechanized bank contacts [3.003, 3.02(5) and (9), and 3.03(5), (9), and (14)].
5. To revise the paragraph covering use of KS-16366 filler can (5.04).
6. To revise the method for pressurizing the flushing unit [6.02(b)].
7. To revise the method for checking KS-16297 L1 flushing unit (Part 7).
8. To add the 269 screwdriver (8.05).

