

## CLEANING EQUIPMENT FRAMES BY MEANS OF COMPRESSED AIR NO. 5 CROSSBAR OFFICES

### 1. GENERAL

**1.01** This section covers the method of pressure cleaning equipment frames in No. 5 crossbar offices. It is intended for use with Section 069-703-801 which covers information applicable to all crossbar offices.

**1.02** This section is reissued to add a caution and reference concerning relays and crossbar switches and to make other changes as required. This reissue does not affect the Equipment Test List.

**1.03** In compliance with specifications, as outlined by the Occupational Safety and Health Act (OSHA), compressed air for cleaning shall be reduced to less than 30 PSI and then shall be used only with chip guarding and personal protective equipment. ♦To meet this objective when using the KS-14758 or De Vilbiss DG-514-2 duster gun, it should be equipped with a KS-14758 L10 booster nozzle.♦

**1.04** All cleaning by means of compressed air shall be done at no more than 30 PSI pressure using a 3/32-inch nozzle.

**1.05** The methods outlined apply to all types of switching apparatus covered herein and are intended for use on all equipment frames on which such apparatus is mounted. The procedures for cleaning perforators and readers are covered in Section 069-370-801.

### 2. METHOD

**2.01** The need for making circuits busy to avoid service reaction depends on the type of

circuits on the frame to be cleaned and on traffic conditions. During extremely light traffic, frames may be cleaned without making the circuits busy. At any other time it is recommended that common equipment such as markers, connectors, and registers be removed from service. Careful consideration should be given to the amount of this equipment made busy so as not to adversely affect service.

#### Covers and Baffles

**2.02** Before preparing a curtained enclosure, as outlined in Section 069-703-801, for the frame group to be pressure cleaned, remove the front and rear covers. See the appropriate section for the method of removing molded plastic covers.

**2.03** Using a damp KS-14666 unimpregnated cloth, wipe both sides of the plastic covers and store in a clean location in an orderly manner so that each cover can be replaced to its original respective position.

**Note 1:** Prepare a sufficient number of KS-14666 unimpregnated cleaning cloths for a cleaning period by wetting the cloths with clear water and wringing them as dry as possible by hand. They should then be folded individually to retain their moisture until used.

**Note 2:** The use of commercial cleaners or window cleaning compounds shall not be used to clean transparent plastic covers since these cleaners may contain abrasives or chemicals which might cause discolorations or brittleness of the covers.

**Note 3:** Avoid rubbing plastic covers with a dry cloth as this will charge the plastic with static electricity which will tend to attract an excessive amount of dust and lint to the covers.

#### NOTICE

Not for use or disclosure outside the  
Bell System except under written agreement

**2.04** Using a KS-14668 impregnated cloth, wipe both sides of the metal covers and store as in 2.03.

**2.05** Vacuum clean the top surfaces of the front and rear baffles, the top surfaces of the mounting plate flanges, and the bottom framework channels of the crossbar switches.

**2.06** Remove the front horizontal baffles using extreme care to prevent dirt which was not removed by the vacuum cleaner from dropping into the equipment. Then using a damp cloth, wipe both sides of each baffle removed and store in a clean location.

**2.07** Place the curtains and set up the apparatus as covered in Section 069-703-801.

**2.08** Remove relay covers, except as indicated below, in accordance with the following.

(a) **Relays Under Common Strip Covers:** Remove the common strip covers for the complete frame.

(b) **Polarized Relays, B- and G-Type Relays, and Wire-Spring Type Relays:** These relays shall be pressure cleaned with the cover caps in place.

(c) **Multicontact Relays (Other Than Wire-Spring Type):** The cover shall be removed from one relay at a time and replaced before proceeding to the next relay.

(d) **Selecting Off-Normal Spring Covers:** The selecting off-normal spring covers of crossbar switches within the curtain enclosure shall be removed.

**Note:** Exercise care in removing the selecting off-normal spring covers so the cover spring is not flexed enough to reduce its tension.

(e) **Relays Under Individual Covers:** Remove the individual covers for the complete frame [except as in (b) and (c)].

**2.09** To clean the covers which have been removed, blow out the inside of the covers with the nozzle held approximately 6 inches away from the cover. This operation shall be done at the exhaustor end of the curtain enclosure before the pressure

cleaning on the frame is started and while the exhaustor sets are operating. Do not direct the air stream toward the frame. Wipe the outside surfaces of the covers using a KS-14668 impregnated cloth, and store outside of the curtain enclosure in a clean location. Store in an orderly manner so no difficulty will be experienced in replacing each cover to its original location.

#### Crossbar Switch Frames, Relay Racks, etc

**2.10** The cleaning of a frame shall start at the point farthest removed from the exhaustor sets, continuing in an orderly manner toward the sets. (See Fig. 1.)

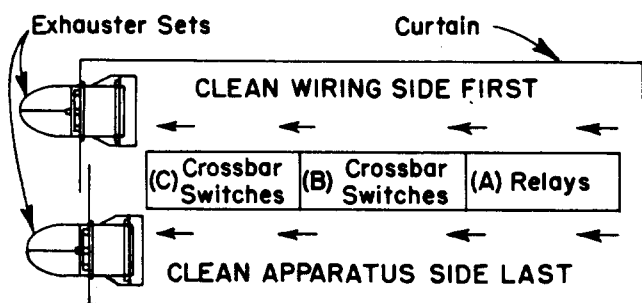

**Fig. 1—Curtain Enclosed Frame With Exhaustor Sets in Place**

**2.11** The sides of the frame group may be divided into arbitrary horizontal and vertical sections of a width that will facilitate orderly cleaning progress. (See Fig. 2.)

**2.12** Starting at the top of the frame, exercising care not to blow dust over the top of the enclosure, clean progressively each vertical section from top to bottom as shown in Fig. 2. Then repeat the procedure for each section.

**2.13** Following the general methods described in 2.10 and 2.11, clean the wiring and forms on the frame by directing and moving the air nozzle in the manner indicated by Fig. 3, 4, and 5. Exercise care that insulation is not damaged. When cleaning the wiring side of wire-spring type relays, point the nozzle downward over the wiring at an angle approximately 30 degrees from vertical, as shown in Fig. 4, so dust and lint will not be blown through openings in the mounting plates onto the springs and contacts of the relay.

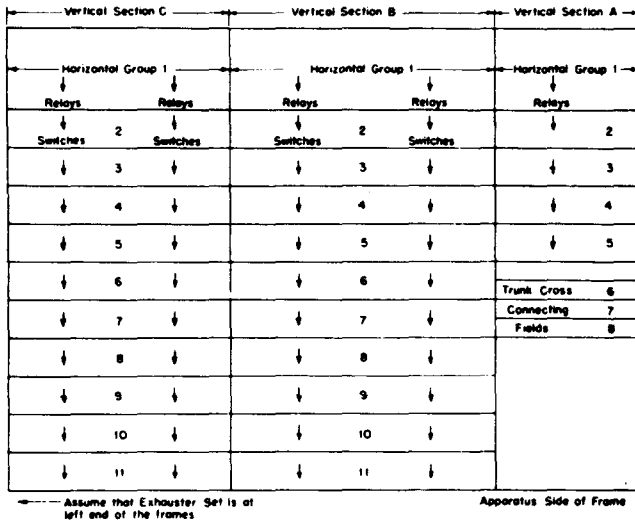
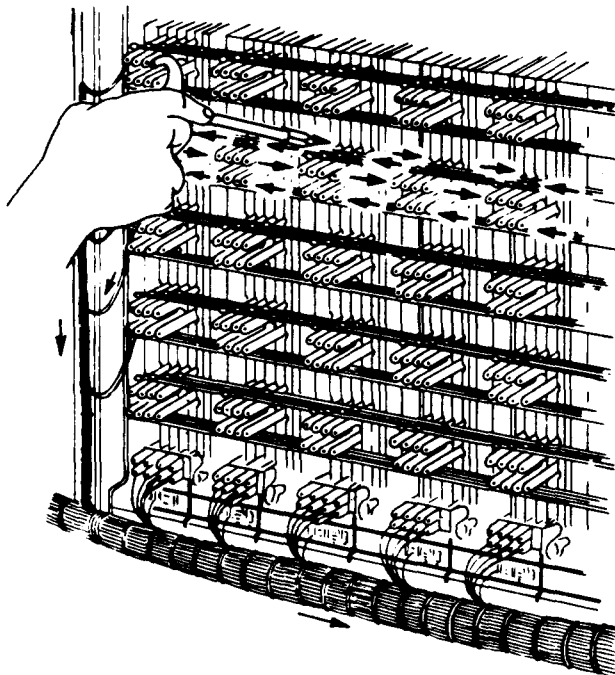
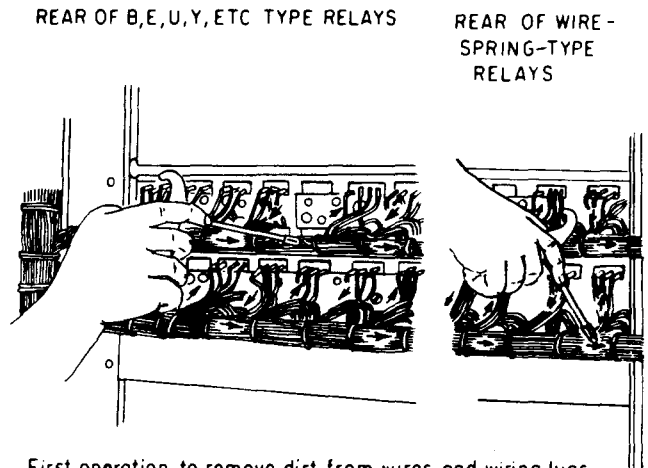

Fig. 2—Apparatus Side of District Group Frame



First operation to remove dirt from vertical forms and wiring.  
 Second operation to remove dirt where wiring lugs enter spring pile up.  
 Third operation to remove dirt where multiple strapping is soldered to wiring lugs.  
 Repeat operations two and three for each row of solder lugs.  
 Final operation to remove dirt from horizontal form and wiring at bottom of switch.

Fig. 3—Rear of Crossbar Switch



First operation to remove dirt from wires and wiring lugs.  
 Second operation to remove dirt from wiring forms.

Fig. 4—Method of Directing Nozzle for Cleaning Rear of B-, E-, U-, Y-, etc., and Wire-Spring Type Relays

2.14 When cleaning the crossbar switch, clean the rear of the vertical units, as shown in Fig. 3. Clean the wiring at the bottom of the switch, as shown for relays in Fig. 4. Clean the wiring at the side of the switch, as shown for multicontact relays in Fig. 5.

2.15 When pressure cleaning horizontal strapping on crossbar switches and multicontact relays, care shall be exercised to see the dust is removed from the location where the strapping is connected to the lugs.

2.16 After the wiring side of the frame has been cleaned, follow the same general methods outlined in 2.10 through 2.12 and clean the apparatus side of the frame.

⚠ **Caution:** Care must be exercised when pressure cleaning the relay springs and crossbar switches. Excessive air pressure directed toward the moving springs of relays and crossbar switches may cause contacts to make or break falsely or selecting fingers to blow out of position. Refer to Section 069-306-801 for additional cleaning procedures.⚠

2.17 When cleaning the apparatus side of the crossbar switches, point the air nozzle

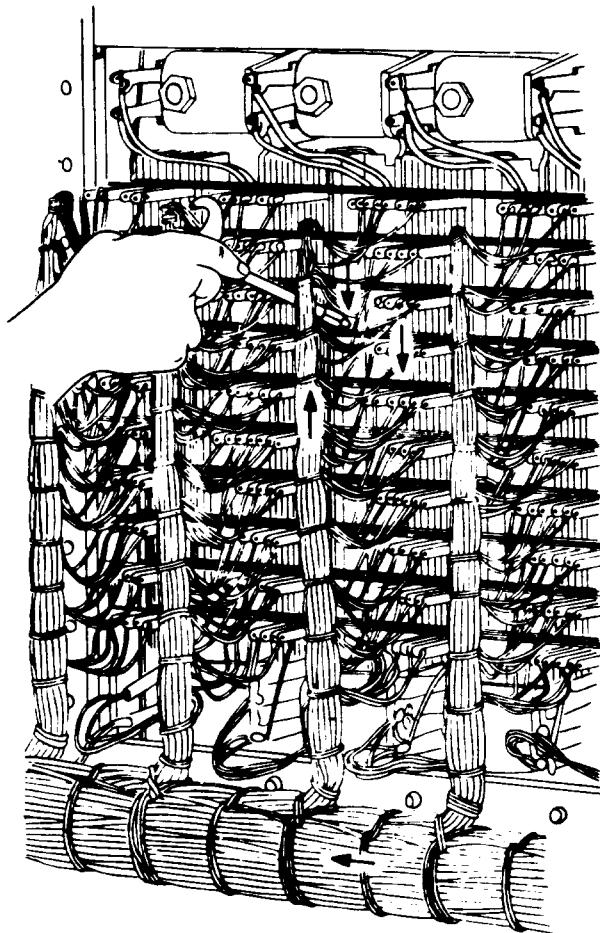

First operation downward to left or right of vertical form to remove dirt from wires and wiring lugs.  
 Second operation upward to remove dirt from vertical form.  
 Third operation downward to right or left (opposite side to first operation) of vertical form to remove dirt from wires and wiring lugs. Repeat operations 1, 2 and 3 for each relay or switch.  
 Last operation to remove dirt from horizontal wiring form.

**Fig. 5—Rear of Multicontact Relay or Multicontact Switch**

downward at an angle of about 45 degrees in order to clean two rows of contacts from above the selecting bar associated with the two rows of contacts, as shown in Fig. 6.

**2.18** When cleaning multicontact relays other than wire-spring type multicontact relays, proceed as indicated by the arrows in Fig. 7, point the air nozzle directly at the end of the relay springs, and work from the top of the relay toward the bottom.

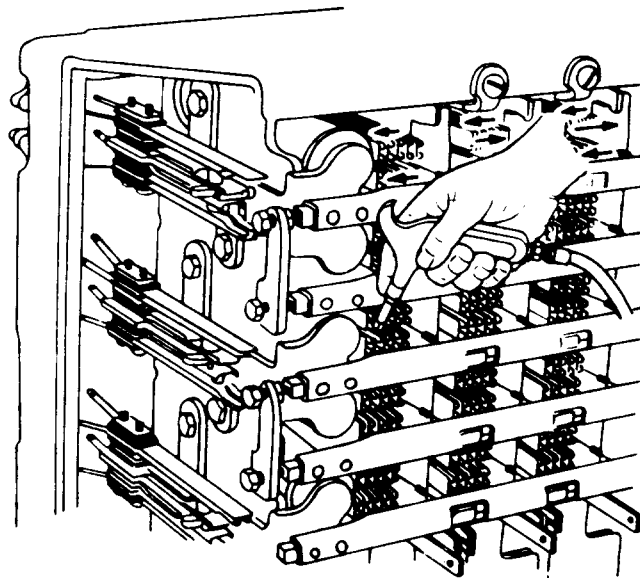

First operation to remove dirt where springs enter pile up and to remove dirt from select magnet coils.  
 Second operation to remove dirt from upper contacts.  
 Third operation to remove dirt from lower contacts.  
 Fourth operation to remove dirt from select off normal springs.  
 Repeat operations one, two, three and four for each two rows of contacts associated with a selecting bar.  
 Final operations  
 A. To remove dirt from hold off normal springs and contacts.  
 B. To remove dirt from hold magnet coils.

**Fig. 6—Front of Crossbar Switch**

**2.19** When cleaning U-type and similar-type relays, progress across the relay mounting plate in the manner indicated by Fig. 8.

**2.20** When pressure cleaning relays (other than wire-spring type) from which covers or caps are not removed, hold the nozzle at least 6 inches from the front of mounting plates where the cover is located and avoid directing the nozzle between two adjacent covers to prevent dirt from being blown under the covers. At the rear of the mounting plate, point the nozzle downward over the wiring so the dirt will not be blown into the cover through openings in the mounting plate.

**2.21** When cleaning wire-spring type relays, have the nozzle tipped slightly downward and about 8 inches away from the relays. Then direct the nozzle over the equipment using slow horizontal strokes starting with the relays at the top of the frame farthest from the exhausters and moving downward and toward the exhausters. Exercise care not to direct the nozzle in such a manner as

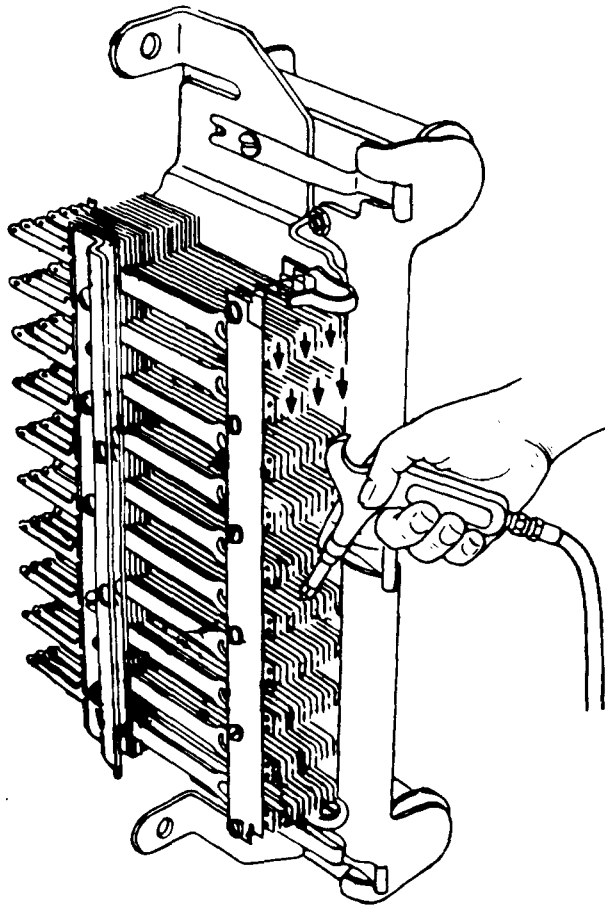

Each operation shall be downward to remove dirt from contacts and where springs enter pile up.

Fig. 7—Front of Multicontact Relay

to dislocate or blow off the plastic covers since this might cause false contacts or displaced springs.

**2.22** As a vertical section of relays has been given the final dusting operation (see 2.23) and before the remaining apparatus and curtains have been given the final dusting operation, replace those relay covers that were removed in their proper locations on the frame.

**2.23** After all the wiring and apparatus within the enclosure have been cleaned, as described above, a final dusting operation shall be performed. In performing this operation, start at the top of the frame farthest from the exhausters, as in previous cleaning, and with the air nozzle pointed slightly downward using a sweeping stroke, work toward the floor removing any dust that may have

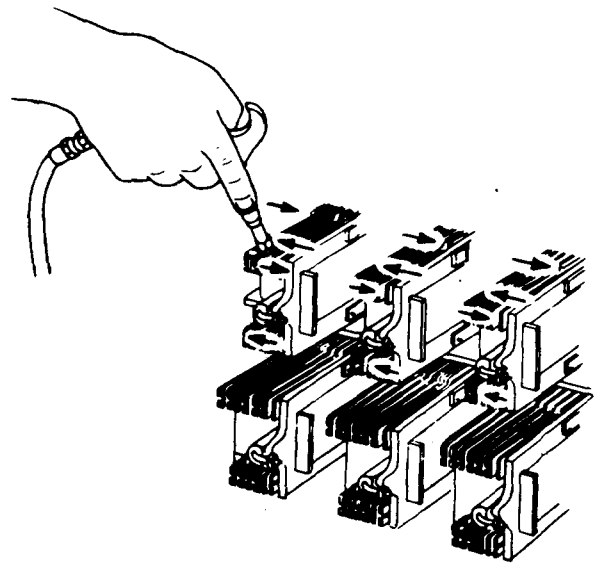

First operation to remove dirt where springs enter pile up.  
Second operation to remove dirt from relay coil.  
Third operation to remove dirt from upper contacts.  
Fourth operation to remove dirt from lower contacts.

Fig. 8—Front of Relay

settled out during cleaning. This final dusting shall be done first on the wiring side, then the apparatus side. Include the curtains and ladders in this operation.

**2.24** Permit the exhauster sets to operate for at least 5 minutes after completing the operation described in 2.23 so any dust suspended in the air inside the enclosure will be removed before proceeding as in 2.25.

**2.25** Move the curtains to the next frame pulling them along the sash cords from which they are suspended. In this connection it will be necessary to remove and relocate any auxiliary supports, such as insulated "S" hooks, that were used to prevent the sash cords from sagging.

**2.26** Exercise care in moving the curtains along the sash cords so they will be agitated as little as possible, thereby reducing to a minimum the possibility of dislodging any dust or lint that may be on their surfaces.

**2.27** Replace the cleaned baffles and frame covers as soon as practicable after the curtains are

moved in order to keep the time that the equipment is unprotected to a minimum.

**Note 1:** The metal separators, for supporting the front horizontal baffles, are not furnished on line link and trunk link frames. In such cases, the upper baffle should be inserted above the top flange of the top mounting plate and the lower baffle should be inserted above the bottom flange of the bottom mounting plate.

**Note 2:** See the appropriate section for the method of mounting molded plastic covers.

**2.28** Wipe off the flat surfaces of the frame just cleaned using a KS-14668 impregnated cloth. Sweep the floor area around the frame using the method described in Division 700 of the appropriate BSP for dustless sweeping in switchrooms.

**2.29** Test the circuits in the approved manner, and return them to service.

**2.30** Proceed as in 2.01 through 2.29 for the next group of frames.

#### **Frames Equipped With Cross-Connecting Fields**

**2.31** When frames equipped with cross-connecting fields are enclosed with the curtains, as in the case of marker and number group frames, clean the wiring side of the entire frame (Fig. 4 and 5); then clean the apparatus side (Fig. 7 and 8), and place the cleaned covers on the relays (2.08 and 2.09) before cleaning the cross-connecting fields as indicated in 2.32.

**2.32** The terminal strips on both sides of the frame shall then be cleaned using slow horizontal strokes starting at the top and away from the exhausters and moving downward and toward the exhausters. Clean the cross-connections with vertical downward strokes always starting from the top of the frame and away from the

exhausters and moving downward and toward the exhausters.

**2.33** When all frames enclosed in the curtains have been cleaned, proceed as covered in 2.23 through 2.29.

#### **Rotary-Type Selectors**

**2.34** With the curtains in place and the apparatus set up and the circuits made busy, clean the wiring forms on the wiring side of the frame associated with the rotary selectors in the same general manner as that used to clean the wiring associated with relays; ie, direct the stream of air, with nozzle pointed slightly downward, slowly over the wiring forms following along the same direction as the wires are formed. (See Fig. 4 and 5.)

**2.35** When cleaning rotary selectors, it is important not to dislodge or blow any excess oil or grease that may be present at the ends of the rotor brush shaft bearings on other parts of the selector. Where excess oil is present on the selector frame, etc, it should be removed by means of KS-14666 unimpregnated cleaning cloth prior to cleaning with compressed air.

**2.36** To clean rotary selectors, it is desirable to have the rotor brushes in motion. Clean by moving the air nozzle slowly across the top of the selector bank in the manner suggested by Fig. 9, exercising care that the brushes do not strike the nozzle. Then with the nozzle directed at the rotor brush shaft, move it slowly across the length of the shaft. The selector if in motion may then be stopped.

**2.37** Clean the selector magnet coil, driving spring, frame, interrupter springs, etc. The space between the outside and inside interrupter springs should be cleaned by directing the nozzle at this space near the insulator between the springs in order to remove dust and the products of wear that may have become lodged at this location.

### 3. SUMMARY OF WORK OPERATIONS

**3.01** This summary is provided for ready reference to facilitate review of the pressure cleaning operation without referring to the entire section. All cleaning operations shall be done with compressed air, pressure regulated to less than 30 PSI, using a 3/32-inch nozzle.

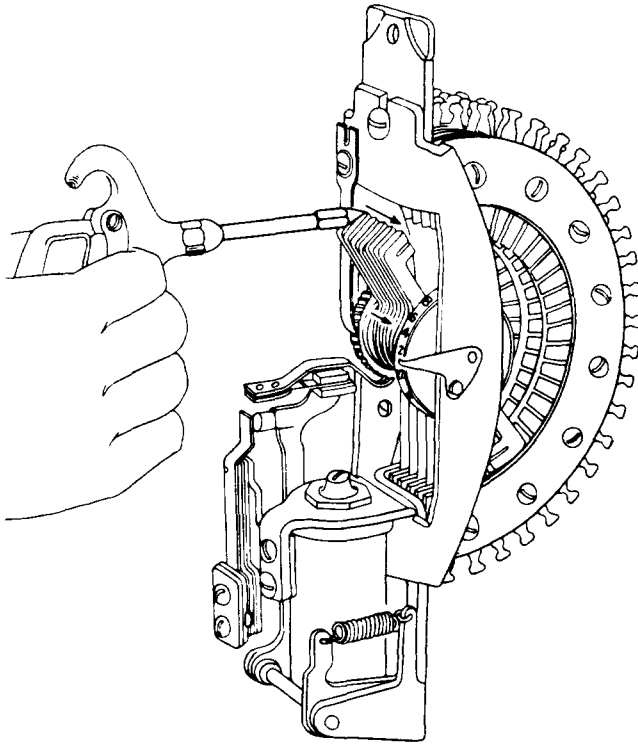

**Fig. 9—206-, 209-, and Similar-Type Selectors**

**SECTION 069-703-803**

METHOD	REFERENCE	METHOD	REFERENCE
A. Vacuum clean cable runs and super-structure.	069-703-801 Par. 1.11	sets. Avoid blowing dust over the top of the curtain enclosure.	
1. Clean ventilating ducts as required.	069-703-801 Par. 1.07 through 1.10	3. Wiring side of multi-contact relays.	
B. Remove front and rear frame covers from group of frames to be pressure cleaned, just before curtains are set up. Wipe and store the covers in a clean location.		4. Wiring side of cross-bar switch.	069-703-803 Par. 2.13 through 2.15 Fig. 3, 4, and 5
1. Vacuum clean the horizontal baffles, etc.	069-703-803 Par. 2.02 through 2.05	5. Wiring side of relay mounting plates.	
2. Remove, clean, and store front horizontal baffles.		F. Equipment side shall be pressure cleaned using the same pattern for cleaning as outlined for the wiring side.	
C. Set up the curtains and pressure cleaning equipment. The exhausters sets shall be in operation while work is in progress within the curtain enclosure.	069-703-801 Part 4	1. U-, Y-, E-, and similar-type relays.	Par. 2.19 Fig. 8
D. Remove, clean, and store apparatus covers to be removed, before the frame is pressure cleaned.	069-703-803 Par. 2.08 and 2.09	2. Wire-spring type relays.	Par. 2.21
E. Clean the wiring side of the frames.	069-703-803 Par. 2.10 through 2.13	3. Crossbar switches.	Par. 2.17 Fig. 6
1. Keep the air stream at the proper pressure and free from oil and moisture.	069-703-801 Par. 1.11 and 1.12 069-703-803 Par. 2.13 and 2.21	4. Multicontact relays.	Par. 2.18 Fig. 7
2. Start pressure cleaning at the top of the bay away from the exhausters sets and progress toward the		5. Frames equipped with cross-connecting fields.	Par. 2.29 and 2.30
		6. Rotary-type selectors.	Par. 2.34 through 2.37 Fig. 9
		G. Final dusting.	Par. 2.23 and 2.24
		H. Replace relay covers.	Par. 2.22
		I. Move curtain.	Par. 2.25 and 2.26
		1. Exercise care in moving not to dislodge dust or lint that may be on its surface.	
		J. Replace baffles and frame covers.	Par. 2.27
		K. Wipe off flat surfaces of equipment just cleaned.	Par. 2.28
		L. Damp dust sweep floor area.	Section H51.104
		M. Make operating tests as required.	Section 069-703-803 Par. 2.29