

TOOLS

WEDGES – DESCRIPTION

1. GENERAL

- 1.01 This section covers coded and noncoded Bell System wedges.
- 1.02 When this section is reissued, the reason for reissue will be listed in this paragraph.
- 1.03 The information contained in this section supersedes the corresponding information in Sections 074-117-101, 074-150-101, and 074-840-101.

Hardwood wedge. The slanted end of the tool may be cut to any required length. Replaces the 93 tool. For use in lifting multiple cable.

410A

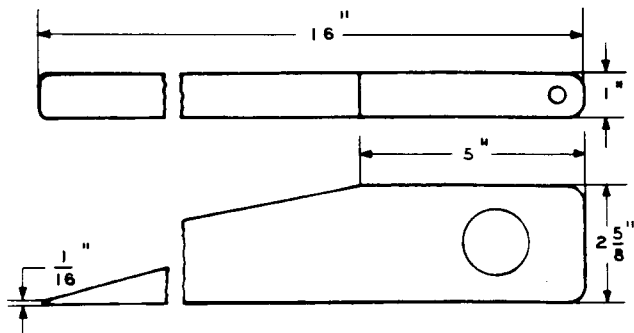

718A

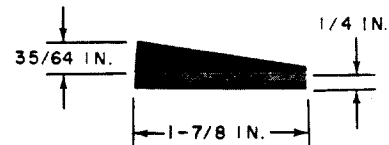

This tool forms part of the 1014B tool kit. For use in replacing coils of AF-, AG-, AJ-, and AK-type relay coils.

Hardwood wedge. Replaces the 93 tool. For use in lifting multiple cable.

R-1994

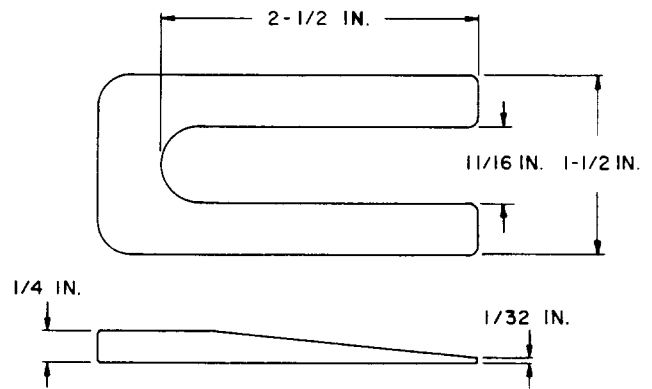

410B

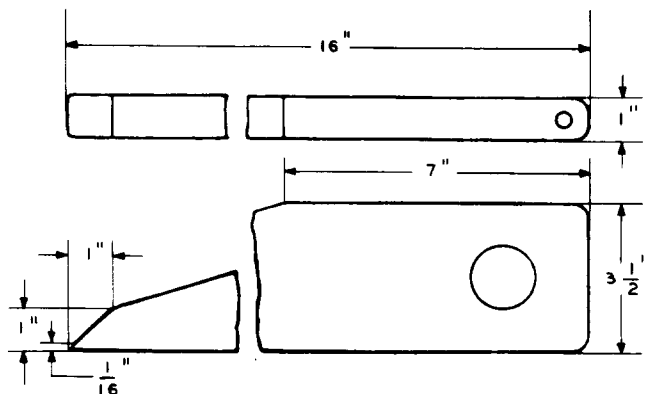

Eccentric coupling wedge. For use on vertical drive shafts.

NOTICE

Not for use or disclosure outside the Bell System except under written agreement