

NONCODED TOOLS

GUNS, (MISCELLANEOUS), HAMMERS, AND HANDLES

DESCRIPTION

GUN, GREASE, LINCOLN ENGINEERING COMPANY,  
5958

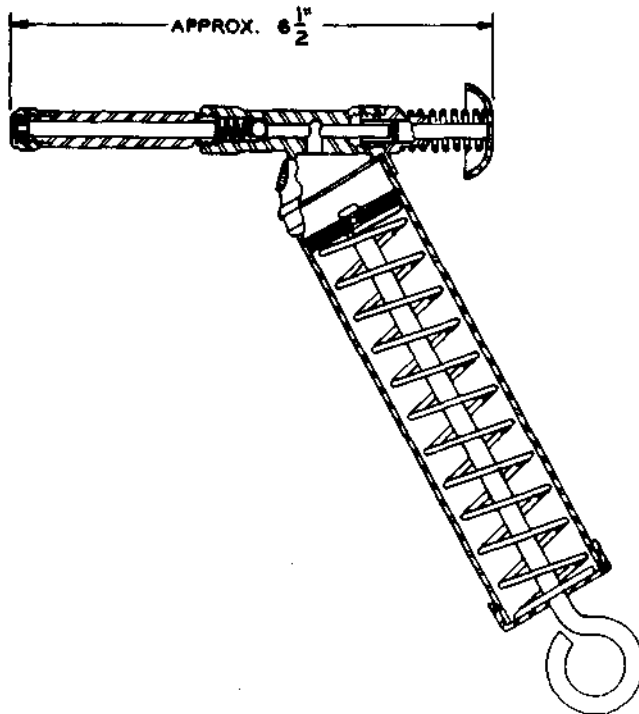

A push-type grease gun having a capacity of 5 ounces and a maximum pressure of 5000 pounds. The nozzle furnished on the gun will fit either pin-type or Zerk-type fittings but does not clamp on to the fitting.

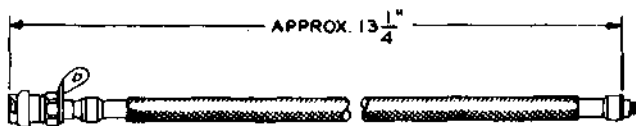

The 3040 hand gun hose, ordered separately, will adapt the gun to clamp on to pin-type fittings.

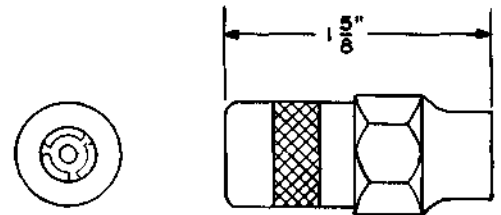

The 5845 hydraulic coupler, ordered separately, will adapt the gun to clamp on to Zerk-type fittings.



Z-737 Alemite nozzle, ordered separately, will adapt the gun for use with Alemite flush-type lubrication fitting 1853.

The 5958 grease gun and the 3040 hand gun hose replace the 5950 grease gun and 3030 hand gun hose formerly manufactured by the Lincoln Engineering Company.

For general use.

GUN, GREASE, KS-7461

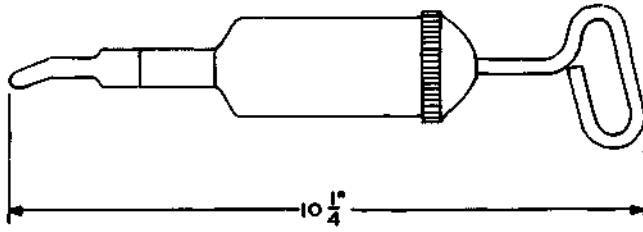

For use on 12-, 14-, and 15-type teletypewriters.

→GUN, GREASE AND OIL COMBINATION, KS-5000←

MFR DISC (1-27-71)

→GUN, HOT-AIR, KS-14586←

(In ordering, specify KS-14586 and list number desired.)

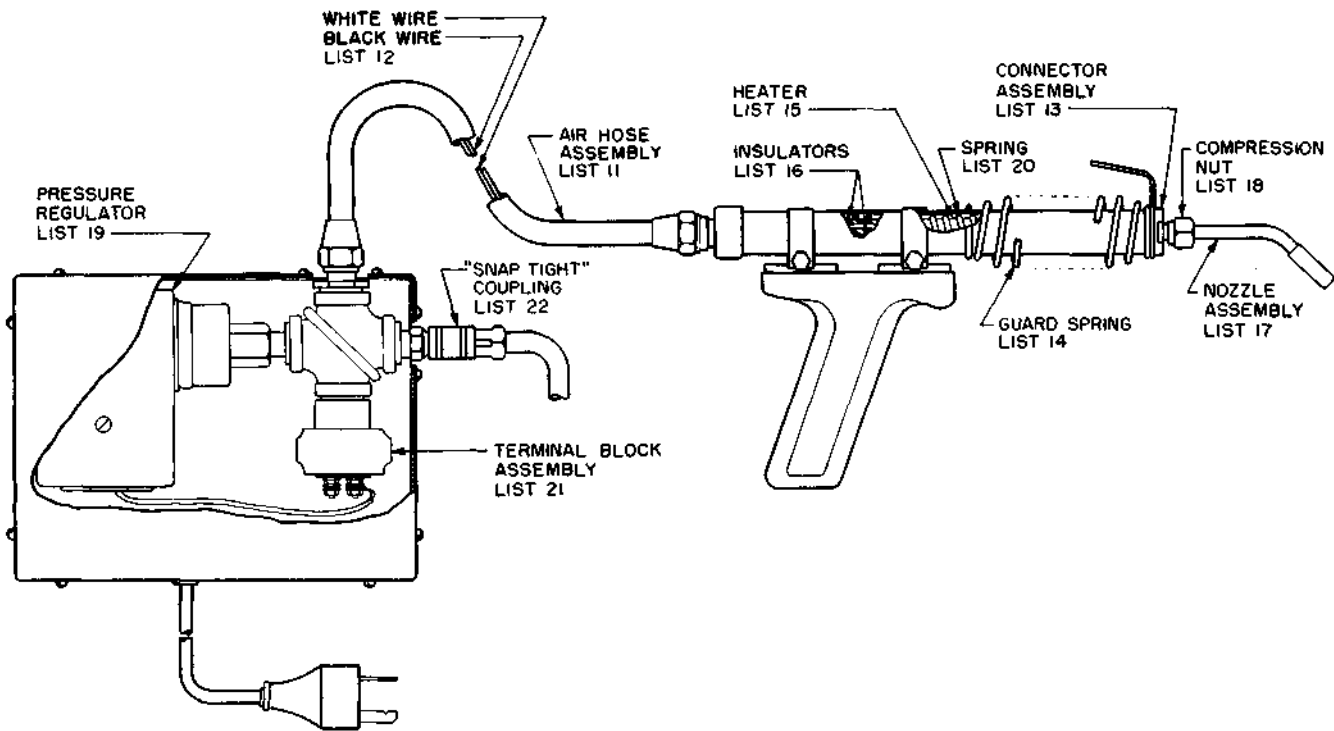

Consists essentially of a gun, an air-hose, and a current control unit and operates on 115 Vac or Vdc with a power consumption of 300 watts.

→GUN, HOT-AIR, KS-14586 (CONT)←

<u>List Number</u>		<u>List Number</u>	
11	Air-Hose Assembly	18	Nut 1/4-Inch Compression, Weatherhead Company, W61X4
12	Black Wire and White Wire	19	Pressure Regulator
13	Connector Assembly	20	Spring
14	Guard Spring	21	Terminal Block Assembly
15	Heater	22	"Snap-Tight" Coupling
16	Insulators, Two		
17	Nozzle Assembly		

For use in removing contact protectant from panel bank guide combs and multiple brush rollers.

**HAMMER, BALL PEEN, 1-POUND**

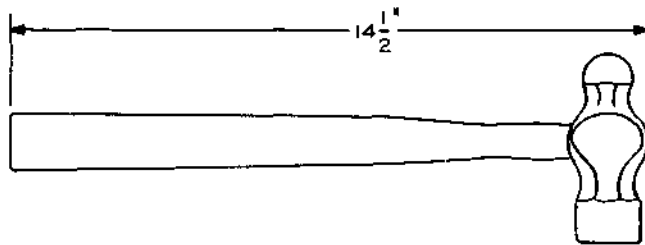

For general use (Specification AT-7329).

**HAMMER, RIVETING, 4-OUNCE**

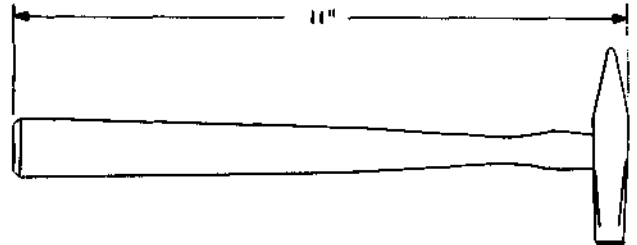

For general use (Specification AT-7329).

**HAMMER, CLAW, 1-POUND**

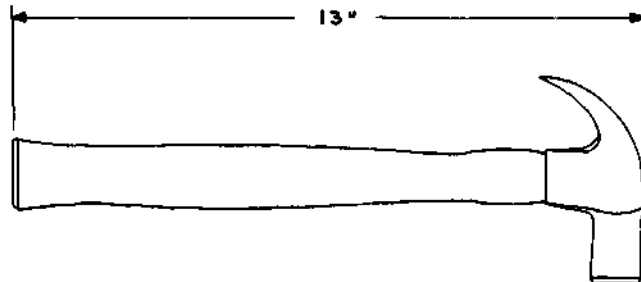

For general use (Specification AT-7329).

**HANDLE, CARRYING, KS-5299**

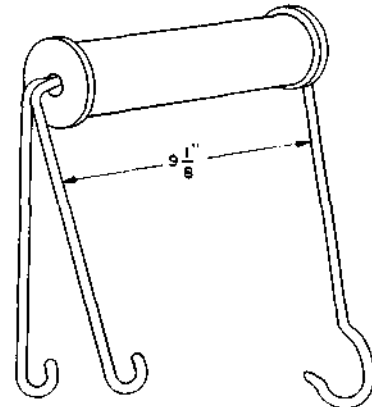

For use in carrying duplex motors.

**HANDLE, FILE, NICHOLSON FILE COMPANY,  
NO. 4 (OR EQUIVALENT)**

For use on files listed in Section 074-600-101.

**HANDLE, GRAVER, WILLIAM DIXON, INC, NO. 15**

For use on the William Dixon, Inc, No. 40 flat graver, which is used in replacing contacts on KS-13835 readers.

**HANDLE, KS-16298**

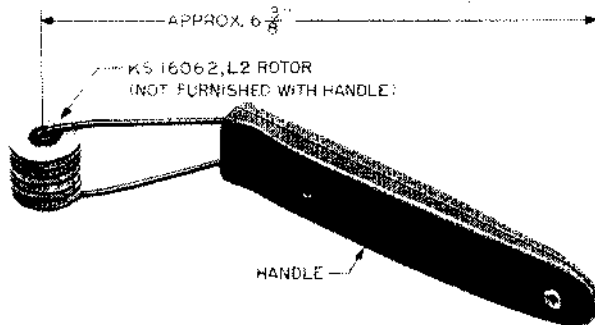

Handle having spring yoke for holding bank cleaning rotor. The KS-16062 L2 rotor used in this tool must be ordered separately. For use in cleaning step-by-step bank contacts and separators.

**HANDLE, KS-16884 L1**

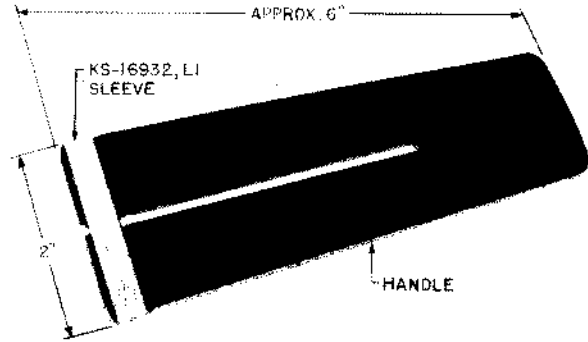

KS-16932 L1 sleeve used with this tool must be ordered separately. For use in cleaning and treating subscriber link district finder bank terminals.

**→GUN, DUSTER, KS-14758 L2←**

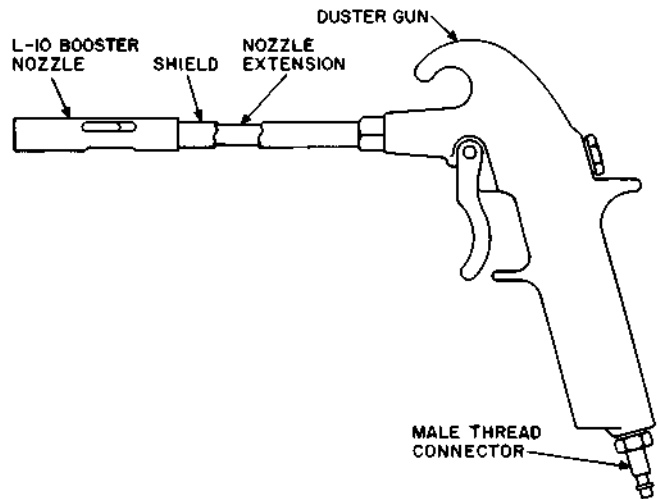

For use with KS-21231 L1 compressor set which replaces the KS-14514 L2 compressor set used for central office cleaning.