

GRAM TENSION GAUGES

62, 68, 70, 79 AND 158 TYPES

REQUIREMENTS AND ADJUSTING PROCEDURES

1. GENERAL

- 1.01 This section covers 62-, 68-, 70-, 79-, and 158-type gram tension gauges.
- 1.02 This section is reissued to add a figure to illustrate the adjustable stop on Nos. 79B and 79C gauges and to cover requirements and adjusting procedures for the Nos. 68D, 70J, and 158A gauges.
- 1.03 Reference shall be made to Section 020-010-711 covering general requirements and definitions for additional information necessary for the proper application of the requirements listed herein.
- 1.04 To protect the reed of a fan-type gauge from damage when the gauge is not in use, the gauge handle when furnished should be folded back and locked in position with the reed in the position shown in Fig. 1 or Fig. 2.

2. REQUIREMENTS

Fan-type Gauge Requirements

2.01 Clearance Between Reed and Scale:

Fig. 1(A) - In all positions of the reed, the clearance between the reed and the scale shall be

For 62- and 158-type gauges - 1/16"

For 68- and 70-type gauges - 1/32"

Gauge by eye.

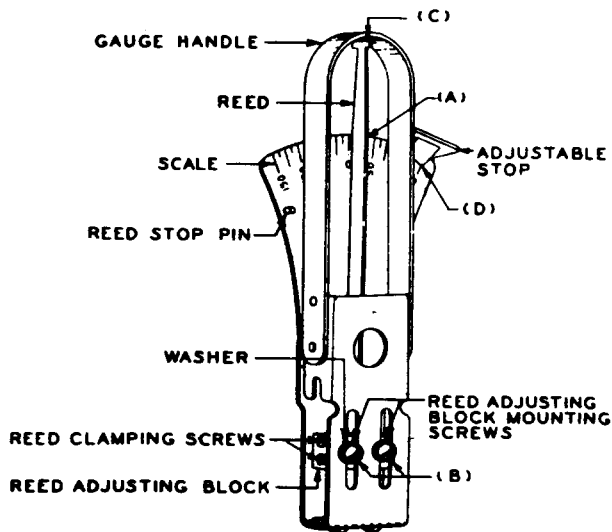

Fig. 1 - Designation of Parts of No. 70E Gauge Gauge by eye.

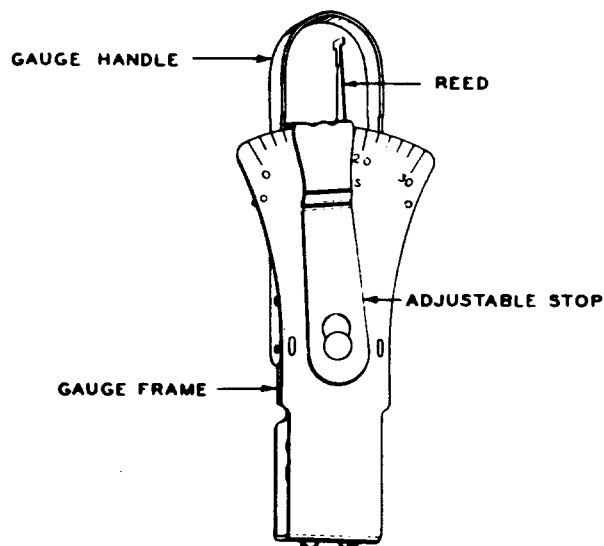

Fig. 2 - No. 70H Gram Gauge with the Handle Folded Back

2.02 Tightness of Clamping Screws or Adjusting Stud Nuts: Figs. 1(B) and 3(A) - The clamping screws or adjusting stud nuts shall be sufficiently tight to hold their adjusted positions.

Gauge by feel.

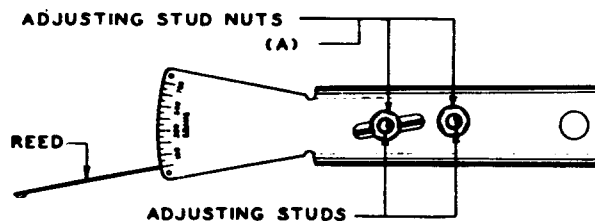

Fig. 3 - Designation of Parts of 62-type Gauge

2.03 Clearance Between Reed and Gauge Handle (68- and 70-type Gauges Only): Fig. 1(C) - With the handle or reed in the position shown in Figs. 1 or 2, there shall be a clearance between the reed and the gauge handle of

Min. 1/32"

Gauge by eye.

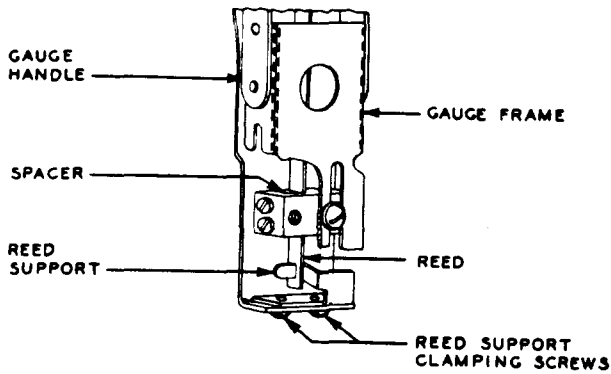

Fig. 4 - Designation of Parts of Nos. 68B, 68C, 68D, 70D, 70E, 70F, 70G, 70H, and 70J Gauges

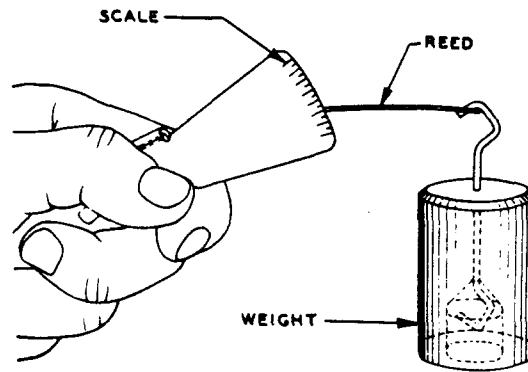

Fig. 5 - Method of Checking Accuracy of No. 62B Gauge

2.04 Tension of Adjustable Stop: Fig. 1(D)

(a) All 68- and 70-type Gauges Except No. 70G: The tension of the adjustable stop shall be sufficient to prevent the tension of the reed from moving it from a predetermined position.

Gauge by eye.

(b) All 68- and 70-type Gauges: The adjustable stop shall slide from one position to another without excessive sticking or binding on the scale.

Gauge by feel.

2.05 Accuracy Limits: The gauge shall meet the accuracy limits specified in the table of limits appearing on page 4 when a weight equivalent to the designated checking value is attached to the reed.

Use the KS-6338 gauge and gauge by eye.

The accuracy limits at zero shall be met with the scale of the gauge in a horizontal position.

To check the accuracy limit at other than zero hold the gauge so that the scale is approximately vertical. Hook the specified weight of the KS-6338 gauge to the end of the reed so that the reed is in a horizontal position as shown in Fig. 5.

Note: The weight of the reed has been considered in setting the accuracy limits for the specified checking value; and it shall be disregarded in checking this value.

Coil-type Gauge Requirements

2.06 Plunger Assembly Position (Nos. 79D, 79E, and 79F Gauges Only): Fig. 6(A) - When the plunger is moved to either extreme position, it shall not touch the cap on the bushing at any point throughout its movement.

Gauge by eye.

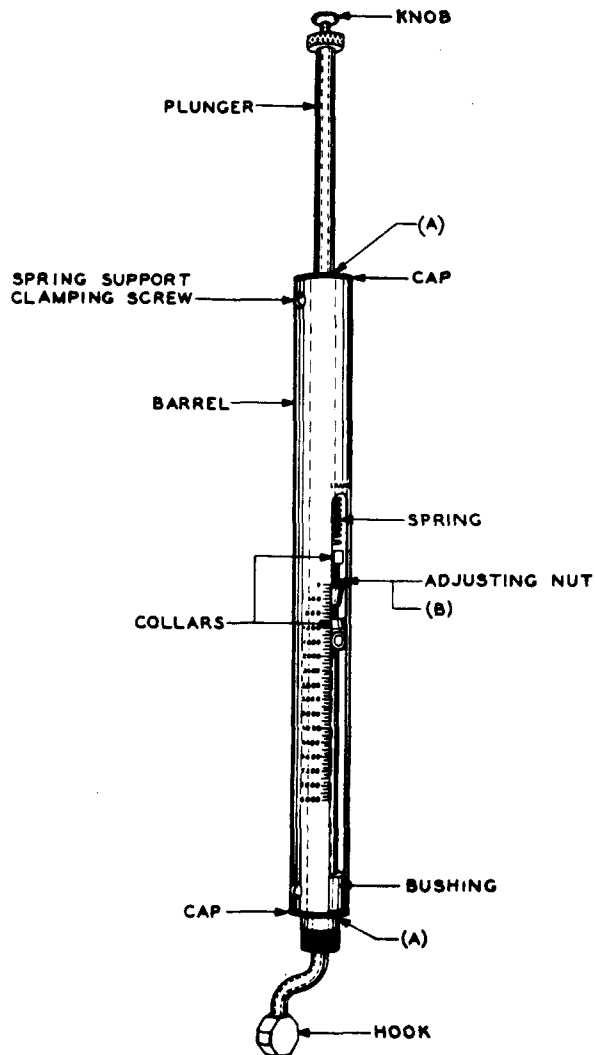

Fig. 6 - Designation of Parts of Nos. 79D, 79E, and 79F Gauges (No. 79E Gauge Illustrated)

2.07 Shaft Assembly Position (Nos. 79D, 79E, and 79F Gauges Only): Fig. 6(B) - When the plunger is moved to either extreme position, the adjusting nut shall not touch the barrel.

Gauge by eye.

2.08 Adjusting Nut Location (Nos. 79D, 79E, and 79F Gauges Only): Fig. 6(B) - With the gauges held in a vertical position, either end at the top, it shall be possible to revolve the adjusting nut to a position where either edge of the indicator groove can be brought into alignment with the zero graduation on the side of the barrel nearest to it. When so adjusted, the clearance between the ends of the adjusting nut and the adjacent surfaces of the associated collars on the Nos. 79D and 79E gauges shall be

Min. 0.015"

Use the No. 68D gauge.

2.09 Freedom of Operation of Plunger: The plunger shall operate freely and shall not be sluggish in restoring to normal.

Gauge by eye and by feel.

2.10 Tightness of Spring Support Clamping Screws: Fig. 6 - The clamping screws shall be sufficiently tight to hold the spring support in its adjusted position.

Gauge by feel.

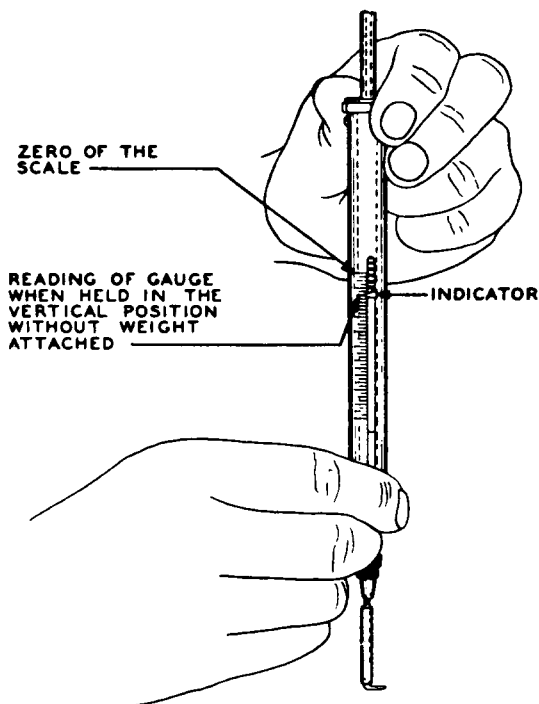

Fig. 7 - Method of Obtaining Zero Reading on a Coil-type Gauge

2.11 Accuracy Limits

(a) The gauge shall meet the accuracy limits specified in the table of limits appearing on page 4 when a weight equivalent to the designated checking value is attached to the plunger.

Use the gauges specified in the table and gauge by eye.

(b) On the Nos. 79A, 79B, and 79C gauges, the accuracy limits at zero shall be met with the gauge in a horizontal position.

(c) Method of Checking the Accuracy Limit of Nos. 79A, 79B, and 79C Gauges at Other Than Zero: Hold the gauge in a vertical position. This will give a deflection from the zero of the scale caused by the weight of the movable plunger as shown in Fig. 7. Record this reading. Attach the KS-6338 gram

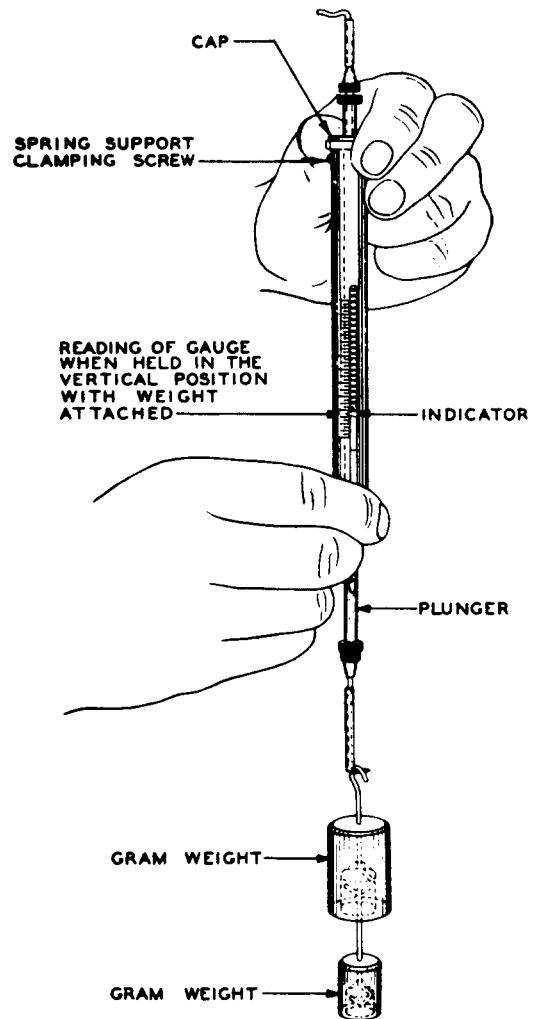

Fig. 8 - Method of Checking Accuracy of a Coil-type Gauge

SECTION 085-102-701

weights, equivalent to the checking values specified in the table, to the plunger by means of the hook on the weight as shown in Fig. 8 and note the reading on the gauge. The reading should check within the limits specified with the value of the check weight added to the weight of the plunger.

(d) Method of Checking the Accuracy Limit of the No. 79E Gauge: Adjust the indicator to the zero position. Attach the No. 93B gauge (loaded to 1300 grams) to the

plunger and observe whether or not the No. 79E gauge is within the specified limits.

(e) Method of Checking the Accuracy Limit of the Nos. 79D and 79F Gauges: Adjust the indicator to the zero position. Tie the 500-gram weight of the KS-6338 gram weights to the hook end of the gauge with No. 6 twine and hook the knife edge of the No. 93B gauge (loaded to 1500 grams) over the bottom hook of the 500-gram weight. Observe whether or not the gauge is within the specified limits.

TABLE OF LIMITS

Gauge Code No.	Range in Grams	Scale Div. in Grams	Accuracy Limits in Scale Divisions at Zero	Accuracy Limits in Scale Divisions with Specified Checking Values in Grams		Gauge for Checking
				Checking Value in Grams	Accuracy Limits in Scale Divisions	
Fan Type						
62	0-700	50	± 0	500	± 1/2	KS-6338
62B	0-700	50	± 0	500	± 1/2	KS-6338
68	70-0-70	5	± 0	† 50	± 1/2	KS-6338
68B	70-0-70	5	± 0	† 50	± 1/2	KS-6338
68C	70-0-70	5	± 0	† 50	± 1/2	KS-6338
68D	70-0-70	5	± 0	† 50	± 1/2	KS-6338
70	50-0-50	5	± 0	† 50	± 1/2	KS-6338
70B	150-0-150	12-1/2	± 0	† 150	± 1/2	KS-6338
70C	10-0-10	1	± 0	† 10	± 1/2	KS-6338
70D	50-0-50	5	± 0	† 50	± 1/2	KS-6338
70E	150-0-150	12-1/2	± 0	† 150	± 1/2	KS-6338
70F	10-0-10	1	± 0	† 10	± 1/2	KS-6338
70G	50-0-50	5	± 0	† 50	± 1/2	KS-6338
70H	0-30	2	± 0	25	± 1/2	KS-6338
70J	0-150	5	± 0	150	± 1	KS-6338
158A	0-1400	100	± 0	1000	± 1/2	††
Coil Type						
79A	0-200	10	± 1/2	125	± 1/2	KS-6338
79B	0-1000	25	± 1/2	600	± 1/2	KS-6338
79C	0-200	5	± 1/2	125	± 1	KS-6338
79D	0-6000	100	-	2000	± 1/2	††
79E	0-3000	50	-	1300	± 1/2	No. 93B
79F	0-6000	50	-	2000	± 1	††

† To be checked on both sides of the zero position.
 †† Use the No. 93B gauge in conjunction with the KS-6338 gram weights.

3. ADJUSTING PROCEDURES

Gauges

3.001 List of Tools, Gauges, and Materials

66D Thickness Gauge Nest
 93B Gram Weights
 KS-6338 Gram Weights

Code or Spec. No. Description

Tools

Materials

45 5/16" Hex. Single-end Socket Wrench
 KS-6854 3-1/2" Screwdriver
 →KS-14164 No. 4 Artists Show Card Brush
 - 6-1/2" P-long-nose Pliers

KS-2423 Cloth
 KS-6232 Oil
 KS-7860 Petroleum Spirits
 - No. 6 Twine

3.002 Recheck all adjustments when any re-adjustments other than those specified in 3.03 and 3.04 have been made.

Fan-type Gauge Procedures

3.01 Clearance Between Reed and Scale
(Rq. 2.01)

3.02 Tightness of Clamping Screws or Adjusting Stud Nuts (Rq. 2.02)

(1) Nos. 62, 62B, 68, 70, 70B, 70C, and 158A Gauges: Failure to meet the clearance requirement on these gauges is generally due to the reed becoming loose in the base or anchor, or to the reed being bent, in which case, replace the reed assembly and recalibrate the gauges as described in 3.05. Tighten all clamping screws or the adjusting stud nuts.

(2) Nos. 68B, 68C, 68D, 70D, 70E, 70F, 70G, 70H, and 70J Gauges: Failure to meet the clearance requirement on these gauges is generally due to the reed not being seated properly in the adjusting block. To adjust for this, loosen the reed adjusting block clamping screws with the KS-6854 screwdriver and place the reed so that its edge rests flush against the slot in the adjusting block throughout the length of the block. Whenever the clamping screws have been loosened, make sure that the reed is in the position just described when tightening the clamping screws. If the clamping screws have been loosened, recheck the calibration of the gauge as described in 3.05. Tighten all clamping screws or the adjusting stud nuts.

3.03 Clearance Between Reed and Gauge Handle
(Rq. 2.03)

(1) Place the handle in the specified position. If necessary, adjust the clearance between the reed and the handle by applying pressure to the sides of the handle in the manner indicated in Fig. 9. In some cases, it may be necessary to adjust the gauge handle with the long-nose pliers.

3.04 Tension of Adjustable Stop (Rq. 2.04)

(1) If the adjustable stop does not hold the reed in the desired position on all gauges except the No. 70G gauge, adjust the lip of the stop with the long-nose pliers as shown in Fig. 11. Do not adjust the stop sufficiently to cause it to bind excessively on the scale.

3.05 Accuracy Limits (Rq. 2.05)

Nos. 62B and 158A Gauges

(1) If it is necessary to adjust for the zero position, loosen the nuts on the two adjusting studs with the No. 45 wrench and locate the reed so that it coincides with the zero mark on the scale. Tighten the nut

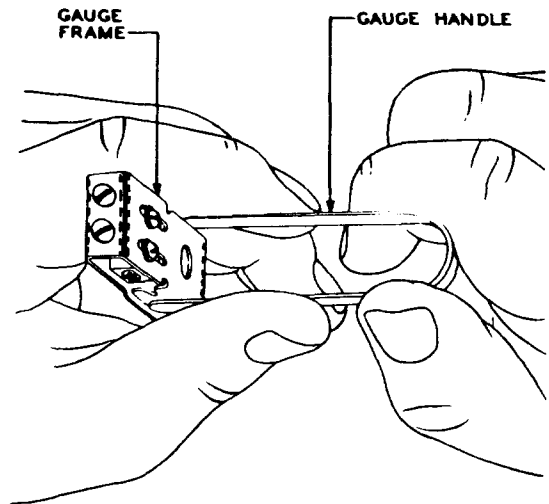

Fig. 9 - Method of Adjusting Clearance Between Reed and Gauge Handle

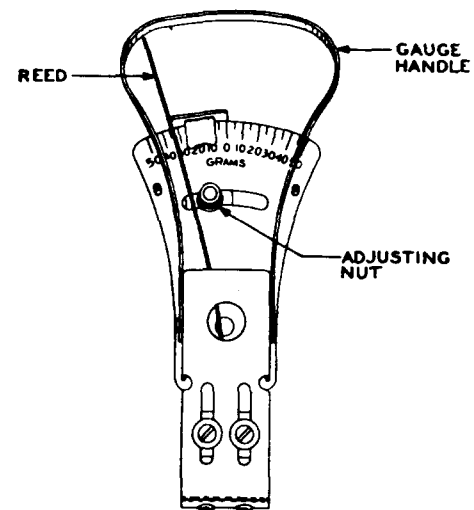

Fig. 10 - Designation of Parts of No. 70G Gauge

nearer the base of the gauge, taking care that the reed maintains its zero adjustment; then tighten the other nut. After the correct zero setting has been obtained, readjust the gauge for accuracy in the following manner.

(2) Where the gauge does not check with the value of the attached weight within the specified limits, loosen the adjusting stud nut nearer the scale of the gauge and move the adjusting stud as required. In cases where the reed deflection is more than the required scale reading, shift the adjusting stud toward the scale of the gauge until the exact reading is obtained.

SECTION 085-102-701

In cases where the reed deflection is less than the required scale reading, shift the adjusting stud away from the scale until the exact reading is obtained. Securely tighten the nut after the correct adjustment has been obtained.

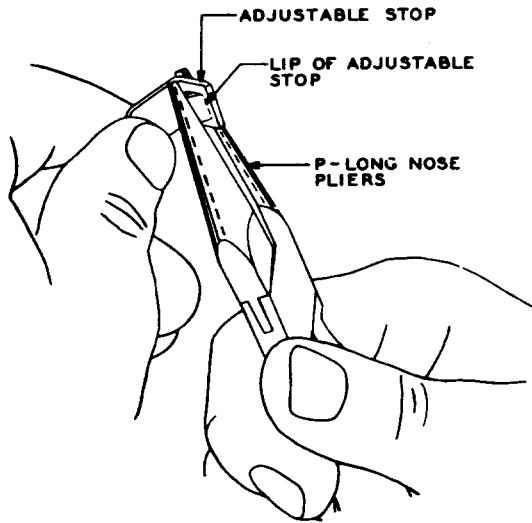

Fig. 11 - Method of Adjusting Adjustable Stop

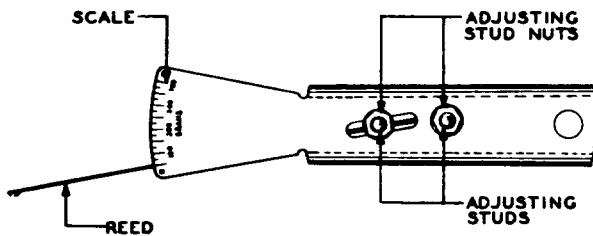

Fig. 12 - Designation of Parts of Nos. 62B and 158A Gauges

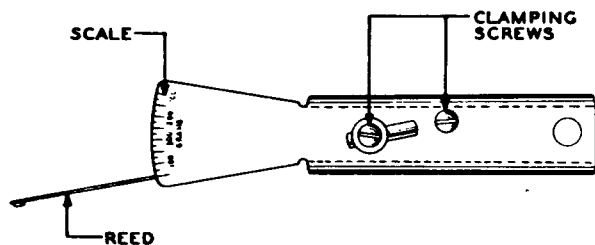

Fig. 13 - Designation of Parts of No. 62 Gauge

No. 62 Gauge Only

(3) If necessary, attempt to adjust for the zero position in accordance with (1); use the KS-6854 screwdriver to loosen the

clamping screws. If the gauge cannot be readjusted, replace the reed.

Nos. 68B, 68C, 68D, 70D, 70E, 70F, 70G, 70H, and 70J Gauges

(4) If readjustments for zero are required, loosen the two reed adjusting block clamping screws in the slots at the back of the gauge with the KS-6854 screwdriver and shift the reed by rotating the reed adjusting block to the left or to the right as required. Then tighten the screws.

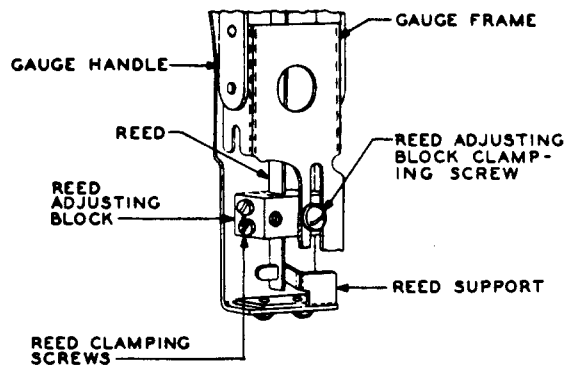

Fig. 14 - Designation of Parts of Nos. 68B, 68C, 68D, 70D, 70E, 70F, 70G, 70H, and 70J Gauges

(5) If the gauge reading is not within the specified limits, loosen the two reed adjusting block clamping screws with the KS-6854 screwdriver. Then loosen the two reed clamping screws with the same screwdriver and shift the reed adjusting block as required. Moving the reed adjusting block toward the scale will decrease the scale reading and moving it away from the scale will increase the scale reading.

(6) After shifting the reed adjusting block, securely tighten the clamping screws, making sure that the reed coincides with the zero mark on the scale.

Nos. 68, 70, 70B, and 70C Gauges

(7) If it is necessary to readjust these gauges for the zero setting, loosen the reed adjusting block clamping screws in the slot at the back of the gauge with the KS-6854 screwdriver. If the reed assumes the correct zero setting after these screws have been loosened, retighten them, taking care not to disturb the zero setting. If this is not the case, turn the two reed anchor clamping screws at the end of the gauge handle in opposite directions with the KS-6854 screwdriver until the reed assumes the correct position. The reed will deflect away from the screw that is turned in the clockwise direction. Tighten the clamping screws, making sure that the zero setting is maintained.

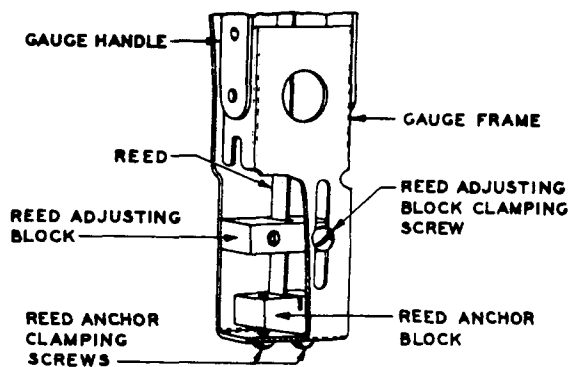

Fig. 15 - Designation of Parts of Nos. 68, 70, 70B, and 70C Gauges

(8) If the gauge reading is still found to be outside of the specified limits, loosen the reed adjusting block clamping screws with the KS-6854 screwdriver and move the reed adjusting block as required. Moving the reed adjusting block toward the scale will decrease the scale reading. Moving the reed adjusting block away from the scale will increase the scale reading.

(9) After shifting the reed adjusting block, securely tighten the reed adjusting block clamping screws, making sure that the reed coincides with the zero mark on the scale.

Coil-type Gauge Procedures

- 3.06 Plunger Assembly Position (Rq. 2.06)
- 3.07 Shaft Assembly Position (Rq. 2.07)
- 3.08 Adjusting Nut Location (Rq. 2.08)

(1) No field readjustment of the gauges is recommended to meet these requirements. If the gauges do not meet these requirements, refer the matter to the supervisor.

3.09 Freedom of Operation of Plunger (Rq. 2.09)

(1) If the plunger does not operate freely, pull it out and clean it with a KS-2423 cloth saturated with KS-7860 petroleum spirits. Then dry it with a clean cloth and apply a small amount of KS-6232 oil.

(2) Nos. 79A, 79B, and 79C Gauges: If the procedure in (1) does not correct the bind, remove the flat-head cap mounting screws with the KS-6854 screwdriver, remove the caps from the ends of the gauge, and clean the bearings using the KS-14164 brush. ← KS-7860 petroleum spirits may be used sparingly if dry cleaning will not remove the dirt. If KS-7860 petroleum spirits is used, apply a small amount of KS-6232 oil to the bearings after cleaning to prevent rusting.

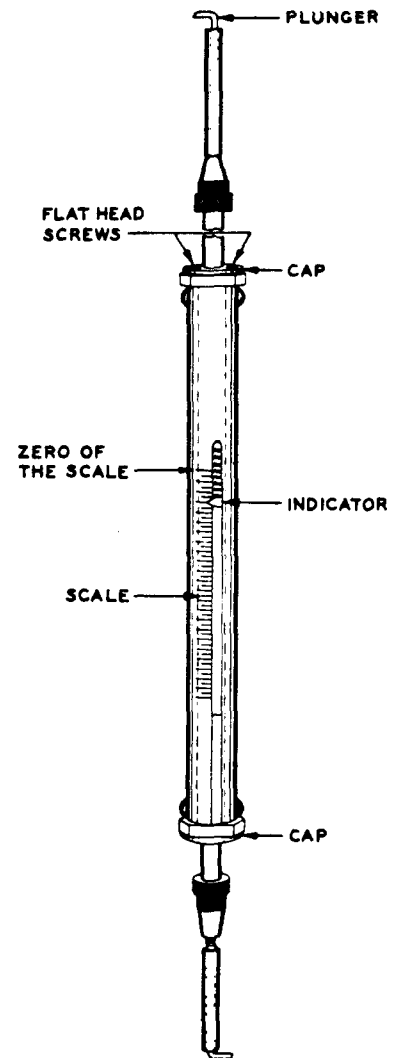

Fig. 16 - Designation of Parts of No. 79A Gauge

Take care in cleaning not to lose the ball bearings. Replace the caps over the ends of the gauge.

- 3.10 Tightness of Spring Support Clamping Screws (Rq. 2.10)
- 3.11 Accuracy Limits (Rq. 2.11)

Nos. 79A, 79B, and 79C Gauges

(1) If necessary to correct the zero position of the indicator, place the gauge on a horizontal surface and carefully remove the flat-head screws from the ball retainer at the zero end of the gauge with the KS-6854 screwdriver. Then remove the ball bearings. Loosen the round-head screws clamping the spring support, using the KS-6854 screwdriver. The spring may then be lengthened or shortened by pulling out the spring support (at the top end) far enough to hold the spring

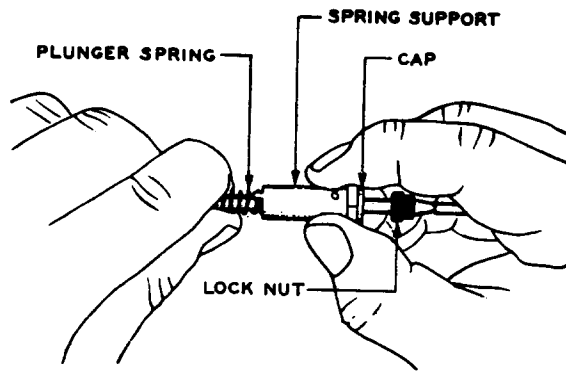
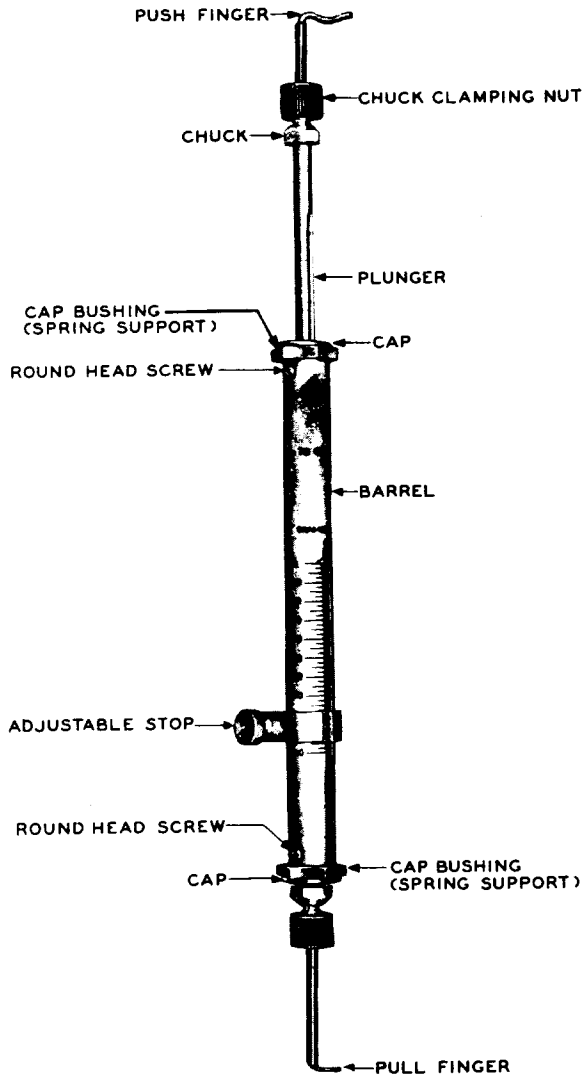

Fig. 18 - Method of Adjusting Tension of Plunger Spring on Nos. 79A, 79B, and 79C Gauges

between the thumb and the forefinger as shown in Fig. 18. With the spring in this position, turn its support in 1/2-turn increments, checking each time for the reading at zero on the scale. To lengthen the spring turn the spring support counterclockwise. To shorten the spring turn the support clockwise. Only infrequently will it be necessary to rotate the support more than one turn in order to change the length of the spring.

(2) Replace the spring support and the round-head screws. Then insert the ball bearings in the slots of the plunger (one in each slot) and replace the cap and the flat-head screws.

Nos. 79D, 79E, and 79F Gauges

(3) If the gauge does not meet the specified requirements, refer the matter to the supervisor.

(4) Make sure that all screws are tight.

Fig. 17 - Designation of Parts of Nos. 79B and 79C Gauges