



14A Announcement System Description and Operating Procedures Common Systems

Contents	Page
1. Overview	1
2. General	3
3. Description	6
4. Function	13
5. Power Requirements	16
6. Applications	16
7. Restrictions	22

Contents **Page**

8.	Operation	22
	A. Monitoring Announcements	22
	B. Measuring and Adjusting Channel Output Transmission Level in Central Office Applications	23
	C. Placing a Channel In Service (Announcement Mode)	25
	D. Taking a Channel Out of Service	25
	E. Removing and Installing ALD1, ALD2, and ALD5 Circuit Packs	26
	F. Removing and Installing AWH1 Circuit Pack	28
	G. Installing and Removing Plug-In Announcement Module	28
	H. Installing an Announcement in the ALD2/ALD5 Circuit Pack	30
	I. Reading ALD2/ALD5 Peg Count	31

9.	Maintenance	31
	A. Checking the Memory Backup Battery on ALD2/ALD5	32
	B. Removing the Memory Backup Battery	33
	C. Installing the Memory Backup Battery	33

10.	Trouble Analysis	34
	A. Diagnostic Test of ALD2/ALD5	37

Figures

1.	14A Announcement System ALD1 Circuit Pack	3
2.	14A Announcement System ALD2 Circuit Pack	4
3.	14A Announcement System ALD5 Circuit Pack	4
4.	14A Announcement System AWH1 Circuit Pack	5

Contents	Page
5. 14A Announcement System Equipped With Two Channels and AWH1 Circuit Pack for 2-Wire Telephone Line Connection	6
6. 14A Announcement System Equipped With Two Channels for Announcement Trunk Connection	7
7. 14A Announcement System Rear Mounting Plate	7
8. ALD1 Circuit Pack Faceplate	11
9. ALD2/ALD5 Circuit Pack Faceplate	12
10. Installation and Removal of Plug-In Announcement Module	29
11. Locating Backup Battery and Announcement Memory on ALD2	32
12. Locating Backup Battery and Announcement Memory on ALD5	33
13. ALD1 Voice Alarm LED Flowchart	35
14. ALD1 Memory Failure LED and Voice Alarm LED Flowchart	36

Tables

A. ALD1 Circuit Pack Major Components	8
B. ALD2/ALD5 Circuit Pack Major Components	9
C. AWH1 Circuit Pack Major Components	9
D. Switch Setting for Announcement Repeated	10
E. ALD1 Controls and Indicators	11
F. ALD2/ALD5 Controls and Indicators	12
G. SITs for ALD1, ALD2, and ALD5	14
H. ALD1/ALD2/ALD5 Functions	15
I. AWH1 Functions	16
J. J1C194A-1 14A Announcement System Equipment List	17
K. ED-7C625-30 Announcement Modules	18
L. Output Transmission Levels for TMS	24
M. Output Transmission Levels for Voltmeter	24
N. ALD1 Trouble Clearing	34

Contents

Page

- O. ALD2/ALD5 Display Trouble Messages
- P. ALD2/ALD5 Menu Display Messages

37

38

1. Overview

- 1.01** This practice describes the 14A Announcement System, a state-of-the-art, completely electronic, announcement system. Since there are no moving parts, the 14A does not need routine maintenance.
- 1.02** This practice is reissued to add information on a new ALD5 circuit pack and to add information on Federal Communications Commission (FCC) Part 68 approval and UL* recognition.
- 1.03** This practice contains admonishments in the form of **CAUTIONS**.

**CAUTION:**

If this equipment is to be connected to standard telephone lines through an interface circuit, or operated as part of a Private Branch Exchange (PBX) system, it must also comply with Part 68 of the FCC regulations. On the mounting plate of this equipment is a label that contains the FCC registration number and Ringer Equivalence Number (REN) for this equipment. If requested, this information must be provided to the telephone company. This equipment is also UL recognized.

**NOTE 1:**

Each telephone service company has standards regarding the signals which will ring devices. This determines the type and number of devices which can be attached to the line. The REN determines the relative value of each device. In most, but not all areas, the sum of the RENs should not exceed five (5.0). To be certain of the number of devices that may be connected to the line, as determined by the total RENs, contact the telephone company to determine the maximum REN for the calling area. The AWH1 interfaces the system to the telephone line for line-side applications. In line-side applications using the AWH1, the 14A system REN is 0.4.

**NOTE 2:**

The telephone company may make changes in its facilities, operations, or procedures that could affect the operation of the equipment. If this happens, the telephone company will provide advance notice in order for you to make the necessary modifications to maintain uninterrupted service.

* Registered trademark of Underwriters' Laboratories, Inc.



NOTE 3:

No repairs should be performed by the customer. If trouble is experienced with this equipment, please contact the following for repair and warranty information:

AT&T Technologies (Customer Service)
6200 East Broad Street
Columbus, OH 43213
phone: (614) 860-2954

The telephone company may request that you remove the equipment until the problem is solved.

1.04 AT&T welcomes your comments on this practice. Your comments will aid us in improving the quality and usefulness of AT&T documentation. Please use the Feedback Form provided at the back of this practice.

1.05 Additional copies of this practice and any associated appendixes may be ordered from the AT&T Customer Information Center as follows:

- Call 1-800-432-6600

or

- Complete Form INDI-80.80 and mail to:

AT&T Customer Information Center
Attention: Order Entry Department
2855 N. Franklin Road
P. O. Box 19901
Indianapolis, IN 46219-1999

1.06 Federal Communications Commission (FCC) Notification and Repair Information

NOTE: This equipment has been tested and found to comply with the limits for a Class A digital device, pursuant to Part 15 of the FCC Rules. These limits are designed to provide reasonable protection against harmful interference when the equipment is operated in a commercial environment. This equipment generates, uses, and can radiate radio frequency energy, and, if not installed and used in accordance with the instruction manual may cause harmful interference to radio communications. Operation of this equipment in a residential area is likely to cause harmful interference in which case the user will be required to correct the interference at his own expense.

1.07 This practice is issued by:

Document Development Organization
Network Systems
2400 Reynolda Road
Winston-Salem, NC 27106-4696

2. General

2.01 The 14A Announcement System has the following three compatible circuit packs that give the user flexibility in recorded announcement service:

- Code ALD1 (Figure 1) — A playback-only unit that uses a prerecorded Erasable Programmable Read-Only Memory (EPROM) announcement module.
- Code ALD2 (Figure 2) — A record/reproduce unit that uses a Random Access Memory (RAM) and can record a unique announcement of up to 30 seconds in length.
- Code ALD5 (Figure 3) — A record/reproduce unit that uses a RAM and can record a unique announcement of up to 2 minutes in length.

All circuitry needed for playback of a recorded announcement is located on each circuit pack.

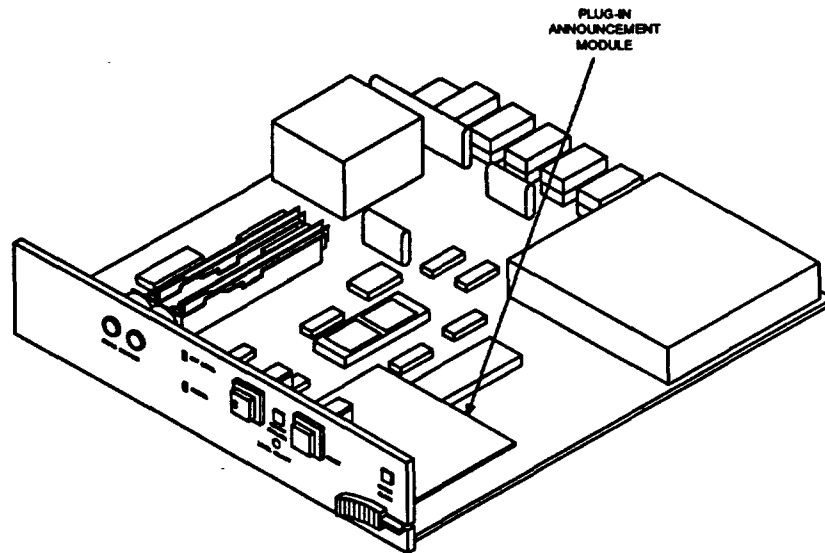

Figure 1. 14A Announcement System ALD1 Circuit Pack

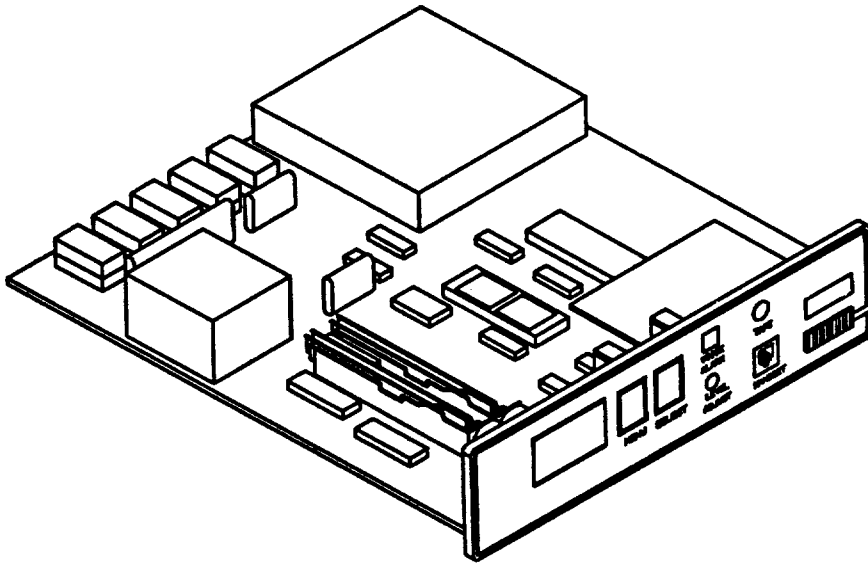

Figure 2. 14A Announcement System ALD2 Circuit Pack

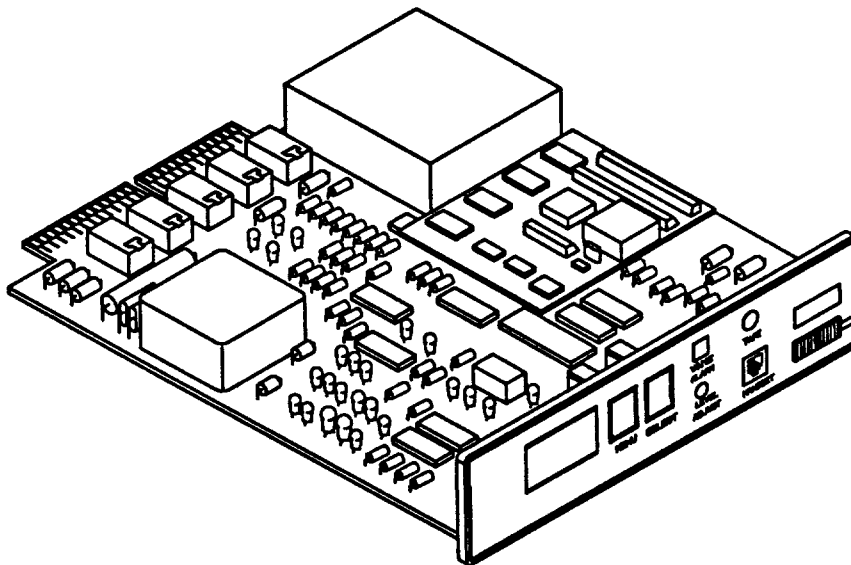

Figure 3. 14A Announcement System ALD5 Circuit Pack

2.02 With the ALD1, ALD2, and ALD5 circuit packs, the user now has a choice of an announcement service that can be based on need for either one channel or several channels. All channels can distribute their announcement output to 500 standard announcement trunks per channel, as in a host local central office. Each basic 14A common equipment unit consists of two circuit pack apparatus mountings and associated connectors. The user choices are:

- Two channels of record/reproduce announcement service via two ALD2s.
- Two channels of playback-only announcement service via two ALD1s.
- Two channels of record/reproduce announcement service via 2 ALD5s with message lengths of up to 2 minutes.
- A combination of any two services via any two of the above.
- A single ALD1, ALD2, or ALD5.

2.03 If the circuit is to be used for connection to a 2-wire telephone line, as in a 5ESS® switch Remote Switching Module (RSM), the AWH1 (Figure 4) circuit pack must be included with one ALD1/ALD2/ALD5 circuit pack for a 1-channel operation or a combination of two ALD1s/ALD2s/ALD5s for a 2-channel operation. ALD1, ALD2, and ALD5 are compatible and interchangeable and may be combined to provide the user with record/reproduce and/or playback-only announcement service.

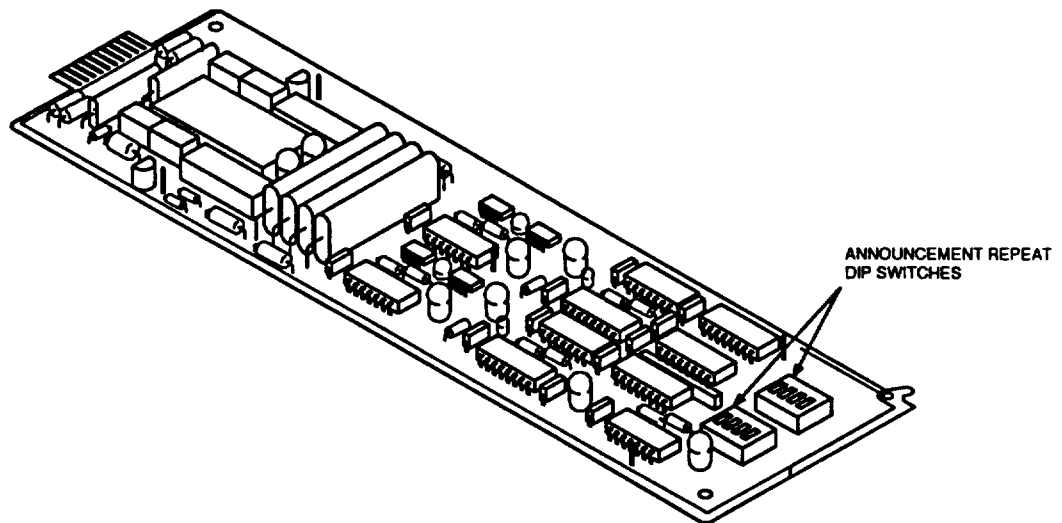

Figure 4. 14A Announcement System AWH1 Circuit Pack

2.04 The 14A Announcement System has been optimized for announcement of standard and unique network announcements preceded by Special Information Tone (SIT) encodings. It is possible to record announcements on the 14A. With the ALD2 or ALD5 circuit pack installed, recordings can be made "LIVE" with a handset plugged into the modular HANDSET jack or dubbed from a tape recorder via the TAPE jack located on the faceplate. If the ALD2/ALD5 is connected to a remote record circuit, an announcement can be recorded from a remote location via a standard telephone line. With the ALD1 circuit pack installed, the digitized speech data for each announcement and its associated SIT encoding is stored in a prerecorded EPROM plug-in announcement module. The modules are nonvolatile and are easily removed and replaced. The modules offer operational and administrative efficiencies since they eliminate the burden and associated cost of recording. Prerecorded announcements also result in consistently higher quality. For unique announcements using the ALD1, special purpose announcement modules can be ordered on a special order basis.

3. Description

3.01 The 14A Announcement System is 2 inches high by 23 inches wide by 11½ inches deep, including the mounting plate and apparatus mountings for two independent channels (Figures 5 and 6). The ALD1/ALD2/ALD5 circuit pack connects to 940A connectors mounted on the mounting plate. The AWH1 line interface circuit connects to an AMP 5-530396-0 connector mounted in the AWH1 apparatus mounting (Figure 7). The 940A connectors connect the channel to the power and distribution trunks for announcement trunk-type service. For line service, connection to the lines and ALD1/ALD2/ALD5 circuit pack is through the AMP 5-530396-0 connector.

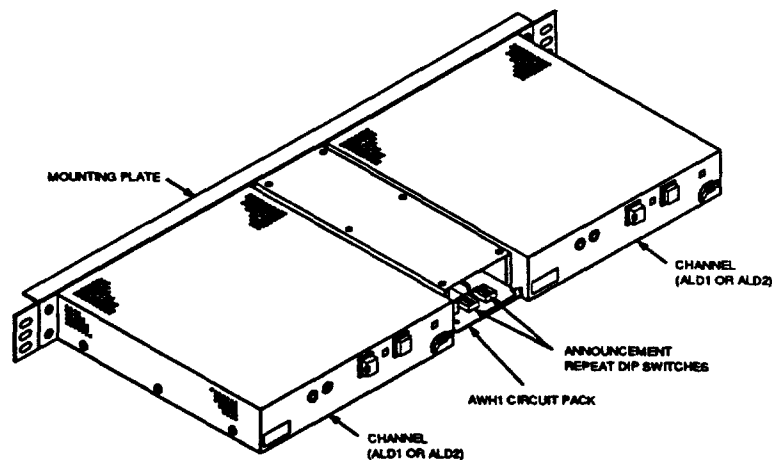

Figure 5. 14A Announcement System Equipped With Two Channels and AWH1 Circuit Pack for 2-Wire Telephone Line Connection

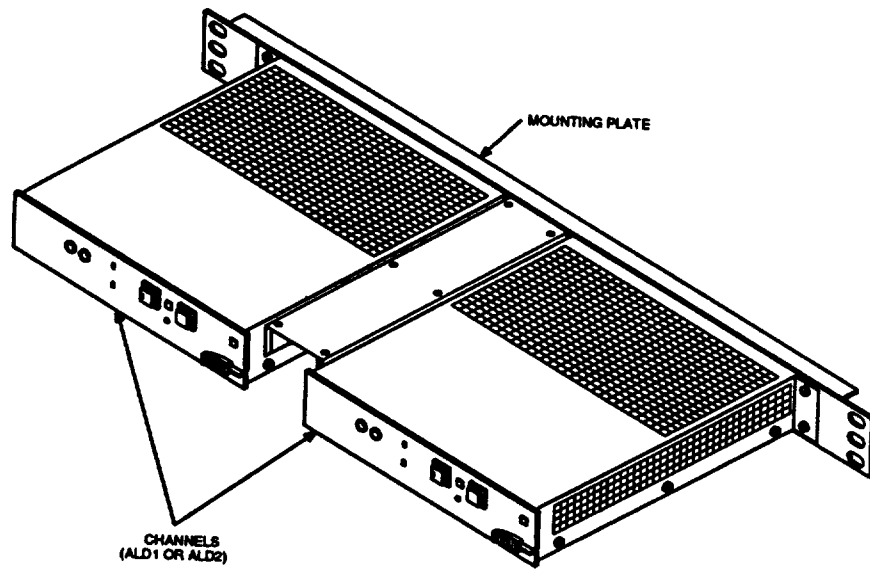

Figure 6. 14A Announcement System Equipped With Two Channels for Announcement Trunk Connection

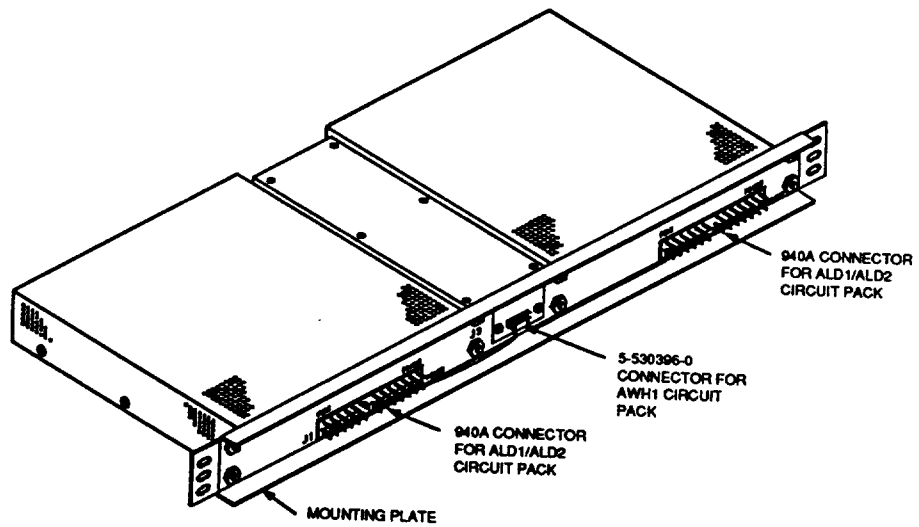

Figure 7. 14A Announcement System Rear Mounting Plate

3.02 For connection to standard announcement trunks, an entire channel is self-contained on either the ALD1, ALD2, or ALD5 circuit pack. Some of the major components of the ALD1, ALD2, and ALD5 are described in Tables A and B, respectively. For connection to a 2-wire telephone line, the AWH1 circuit pack must be included. Some of the major components of the AWH1 are described in Table C. This circuit provides a 4-pole ANNOUNCEMENT REPEAT Dual In-line Package (DIP) switch (S1 and S101). This switch is connected to the data input of a binary counter. By selecting the timed sequence of switch settings, the announcement may be repeated up to 15 times (Table D). The AWH1 contains two circuits, one for each of the ALD1, ALD2, or ALD5 circuit packs that can be installed. Both circuits are identical and have the same function.

Table A. ALD1 Circuit Pack Major Components

Component	Description
Microcomputer	Handles overall control of the pack, including diagnostics to monitor for proper operation, and detects failures and initiates alarms.
EPROM Memory	Stores the compressed digital data representing the announcement and associated SIT encoding.
Speech Synthesizer	Converts the compressed digital version of the announcement and SIT encoding stored in the EPROM to an uncompressed version.
Digital-to-Analog Converter	Converts the digital output of the speech synthesizer to analog speech.
Transformer Coupled Output Amplifier	Provides a low output impedance for distribution to multiple trunk circuits and allows gain adjustment to meet transmission requirements.

Table B. ALD2/ALD5 Circuit Pack Major Components

Component	Description
Microcomputer	Handles overall control of the pack, including diagnostics to monitor for proper operation, and detects failures and initiates alarms.
Announcement Memory	Stores the compressed digital data representing the announcement and associated SIT encoding. Memory has battery backup.
Speech Processor	During record function, converts analog speech and SIT to compressed digital data for storage in the announcement memory. During playback function, converts the compressed digital data in the announcement memory to analog speech and SIT for the announcement.
Transformer Coupled Output Amplifier	Provides a low output impedance for distribution to multiple trunk circuits and allows gain adjustment to meet transmission requirements.

Table C. AWH1 Circuit Pack Major Components

Component	Description
Ring Detector	Detects and trips the ring and generates a signal suitable to drive an opto-isolator.
Opto-Isolator	Controls the operation of a relay which connects the tip and ring leads of the ALD1/ALD2/ALD5 circuit pack through the AWH1 circuit pack to the tip and ring leads of the 2-wire telephone line being served.
Binary Counter and Announcement Repeat DIP Switch	Controls the number of times the announcement is repeated. (See Table D.)

Table D. Switch Setting for Announcement Repeated

Switch Position				Announcement Repeated
1	2	3	4	
ON	OFF	OFF	OFF	One time
OFF	ON	OFF	OFF	Two times
ON	ON	OFF	OFF	Three times
OFF	OFF	ON	OFF	Four times
ON	OFF	ON	OFF	Five times
OFF	ON	ON	OFF	Six times
ON	ON	ON	OFF	Seven times
OFF	OFF	OFF	ON	Eight times
ON	OFF	OFF	ON	Nine times
OFF	ON	OFF	ON	Ten times
ON	ON	OFF	ON	Eleven times
OFF	OFF	ON	ON	Twelve times
ON	OFF	ON	ON	Thirteen times
OFF	ON	ON	ON	Fourteen times
ON	ON	ON	ON	Fifteen times

3.03 System controls and indicators are located on the faceplates of the ALD1 (Figure 8) and ALD2/ALD5 (Figure 9). These controls are described in Tables E and F, respectively.

**CAUTION:**

Output level is preset and the level is protected by a plastic cap. User adjustment may void FCC registration.

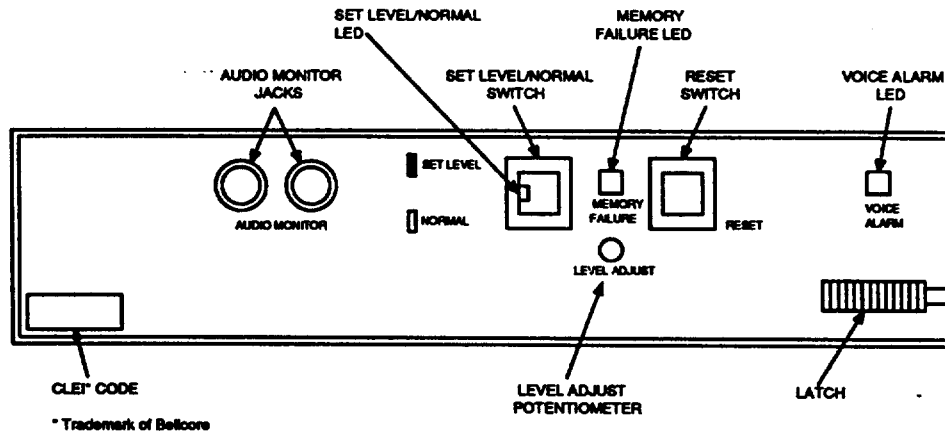

Figure 8. ALD1 Circuit Pack Faceplate

Table E. ALD1 Controls and Indicators

Component	Description
AUDIO MONITOR	A jack used to connect a handset to monitor the recorded announcement.
SET LEVEL/NORMAL	A pushbutton switch used in adjusting the output transmission level.
SET LEVEL/NORMAL LED	A light emitting diode (LED) used to indicate, when lighted, that the 1000-Hz reference tone is being generated by the ALD1.
RESET	A pushbutton switch used to clear alarm conditions caused by a temporary fault.
MEMORY FAILURE	An LED used to show failures in the announcement module memory.
LEVEL ADJUST	A potentiometer used to adjust the output transmission level.
VOICE ALARM	An LED used to show failures in the ALD1.

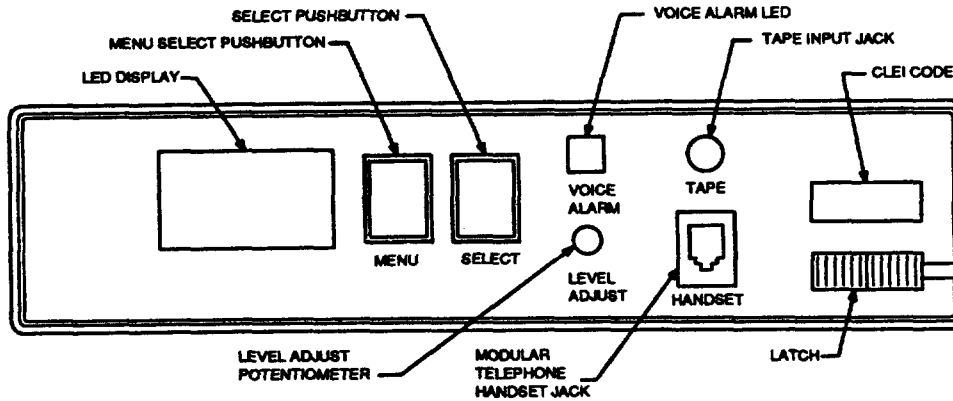

Figure 9. ALD2/ALD5 Circuit Pack Faceplate

Table F. ALD2/ALD5 Controls and Indicators

Component	Description
DISPLAY	An alphanumeric display that indicates a programmable function or the status of the ALD2/ALD5.
HANDSET	A modular telephone jack to connect a handset to monitor the recorded announcement on the ALD2/ALD5 or to record an announcement.
LEVEL ADJUST	A potentiometer used to adjust the output transmission level.
MENU PUSHBUTTON	A pushbutton switch used to step the ALD2/ALD5 microprocessor through the programmable functions.
SELECT PUSHBUTTON	A pushbutton switch used to select the programmable function displayed or to end an operation.
TAPE	A jack that can be used to input a recorded announcement from a tape recorder.
VOICE ALARM	An LED used to show that a failure has occurred in the ALD2/ALD5 and that a voice alarm has generated.

4. Function

4.01 Announcements are played to the trunk or line circuits by decoding the digital speech data stored in the ALD1, ALD2, or ALD5 memory. An on-board microprocessor controls the system operation and continuously runs diagnostics on the circuits.

4.02 An announcement sequence begins after the ALD1/ALD2/ALD5 receives a START signal from an announcement trunk circuit or from the line interface circuit, AWH1. This action generates a 1-second duration cut-through signal to the trunk or line circuits. When the cut-through signal ends, the announcement begins, preceded by its associated SIT encoding when SITs have been selected. For trunk connections, this sequence continues as long as the START signal is present on the ALD1/ALD2/ALD5. For line-side application, the sequence continues until the binary counter on the AWH1 reaches the preset value of repeats on the ANNOUNCEMENT REPEAT switch or until the user hangs up. For a list of the seven network conditions and associated SIT encoding frequencies, refer to Table G.

Table G. SITs for ALD1, ALD2, and ALD5

Network Reportable Condition Shown in ALD2/ALD5 Display	Type of SIT	Tone 1 (HZ)	Tone 1 Duration (MS)	Tone 2 (HZ)	Tone 2 Duration (MS)	Tone 3 (HZ)	Tone 3 Duration (MS)
INTERCPT	Intercept	913.8	274	1370.6	274	1776.7	380
InLATANC	No Circuit*	913.8	380	1370.6	380	1776.7	380
VAC CODE	Vacant Code	985.2	380	1370.6	274	1776.7	380
InLATARO	Reorder*	985.2	274	1370.6	380	1776.7	380
NO CKT	No Circuit	985.2	380	1428.5	380	1776.7	380
REORDER	Reorder	913.8	274	1428.5	380	1776.7	380
INEFF OT	Ineffective Other	913.8	380	1428.5	274	1776.7	380
SIT #8†		913.8	274	1428.5	274	1776.7	274
SIT #9†		913.8	380	1428.5	274	1776.7	274
SIT #10†		913.8	274	1428.5	380	1776.7	274
SIT #11†		913.8	380	1428.5	380	1776.7	274
SIT #12†		913.8	274	1428.5	274	1776.7	380
SIT #13†		913.8	380	1428.5	380	1776.7	380
SIT #14†		913.8	274	1370.6	274	1776.7	274
SIT #15†		913.8	380	1370.6	274	1776.7	274
SIT #16†		913.8	274	1370.6	380	1776.7	274
SIT #17†		913.8	380	1370.6	380	1776.7	274
SIT #18†		913.8	380	1370.6	274	1776.7	380
SIT #19†		913.8	274	1370.6	380	1776.7	380
SIT #20†		985.2	274	1428.5	274	1776.7	274
SIT #21†		985.2	380	1428.5	274	1776.7	274
SIT #22†		985.2	274	1428.5	380	1776.7	274
SIT #23†		985.2	380	1428.5	380	1776.7	274
SIT #24†		985.2	274	1428.5	274	1776.7	380
SIT #25†		985.2	380	1428.5	274	1776.7	380
SIT #26†		985.2	274	1428.5	380	1776.7	380
SIT #27†		985.2	274	1370.6	274	1776.7	274
SIT #28†		985.2	380	1370.6	274	1776.7	274
SIT #29†		985.2	274	1370.6	380	1776.7	274
SIT #30†		985.2	380	1370.6	380	1776.7	274
SIT #31†		985.2	274	1370.6	274	1776.7	380
SIT #32†		985.2	380	1370.6	380	1776.7	380

* SIT encoding associated with inter-LATA carrier call handling.

† SITs numbered 8 to 32 are undefined.

4.03 A complete list of all functions available at the 940A connector for each ALD1/ALD2/ALD5 channel is given in Table H. The functions available at the AMP 5-530396-0 connector for both channels of the AWH1 are given in Table I.

Table H. ALD1/ALD2/ALD5 Functions

Lead Designation	940A Conn. Pin No.	Function
-48 V -48 V RET	2 1	Talk battery connection.
START START RET	26 5	Closure between these leads starts announcement cycle.
CT1 CT2	14 15	Cut-through signal. These leads shorted for 1 second at start of announcement cycle.
MU2 MU3 MU4	35 12 36	Mute signals. MU3 and MU4 leads shorted at start of announcement cycle, opened at end of cycle. MU2 and MU3 leads shorted at end of announcement cycle, opened at beginning of cycle.
STP GRD LIM	30 7 32	Stop and limit signals. STP is normally grounded but is ungrounded for 200 ms at end of announcement cycle. LIM is normally ungrounded but is grounded for 200 ms at end of announcement cycle.
VA1 VA2 VA3	27 29 28	Voice alarm signals. VA1 and VA2 closed during alarm. VA2 and VA3 open during alarm.
VATST1 VATST2	38 6	Voice alarm test leads. Closure of these leads will initiate test of voice alarm circuit.
T R	20 50	Tip and ring leads.

Table I. AWH1 Functions

Lead Designation	5-530396-0 Conn. Pin No.		Function
	CH0	CH1	
T R	13 15	1 3	Connects to the 2-wire telephone line being served.
T R	14 16	2 4	Connects to the audio output T and R leads of the ALD1 circuit pack.
START START RET	17 19	5 7	Provides a closure to the ALD1 circuit pack to start the announcement.
CT1 CT2	18 20	6 8	Leads CT1 and CT2 (cut-through) receive a closure from the ALD1 circuit pack to indicate the beginning of the announcement. It is used as the input CLK of the 4-bit binary counter.
-48 V -48 V RET	10 12	10 12	Talk battery connection.

5. Power Requirements

5.01 The power required for the 14A is -48 V DC. The voltage limits are -39.5 to -57 V DC. The preferred source of this power is TALK battery, but SIGNAL battery power is acceptable if TALK battery is not available in the frame in which the 14A is installed. The normal current drain is 0.16 amperes per ALD1/ALD2/ALD5 and 0.030 amperes for AWH1. Power is protected by a separate 0.25A fuse for the ALD1/ALD2/ALD5 and a 0.1A fuse for the AWH1 in the frame power distribution circuitry.

6. Applications

6.01 For connection to standard announcement trunks, each 14A channel can supply 500 trunk circuits simultaneously. The input/output interface between these trunk circuits and the 14A emulates the 13A and 7A Announcement Systems. Therefore, the 14A can serve the same trunk circuits as the 13A and 7A Announcement Systems.

6.02 The 14A is equipment coded J1C194A-1. The channel circuit packs are apparatus coded ALD1, ALD2, ALD5, and AWH1. The plug-in Announcement Modules are group equipment coded ED-7C625-30. Basic equipment and mounting brackets for the 14A are listed in Table J. Available standard Announcement Modules

are listed in Table K. Customized announcements for the ALD1 are available by special order only and must be limited to a duration of 24 seconds. Announcements for the ALD2 may be any length up to 30 seconds maximum. Announcements for the ALD5 may be any length up to 2 minutes.

Table J. J1C194A-1 14A Announcement System Equipment List

Equipment	List No.	Qty
Apparatus required to equip one channel for playback-only capability (ALD1)	2	1
Common Systems Electronic Central Office Single-Bay Framework Mounting Brackets for ED-97735-70 (Group 1) Frame	6	1
Mounting Brackets for ED-26524-70 (Groups 2 and 7 — No. 5 Crossbar System Single-Bay Framework) Frame	7	1
Equipment and wiring required for line side interface (2-channel interface)	8	1
14A Announcement System — Equipped with apparatus mountings for two circuit packs	9	1
Apparatus required to equip one channel for record/reproduce capability for message lengths of up to 30 seconds (ALD2)	10	1
Apparatus required to equip one channel for record/reproduce capability for message lengths of up to 2 minutes (ALD5)	11	1
ED-Coded Announcement Modules (one per ALD1)	*	1

* See Table K.

Table K. ED-7C625-30 Announcement Modules

SIT	Announcement	List No.
Intercept	We're sorry. You have reached a number that has been disconnected or is no longer in service. If you feel you have reached this recording in error, please check the number and try your call again.	51
Intercept	We're sorry. You have reached a number that has been disconnected or is no longer in service. Please check the number and dial again or stay on the line and an operator will answer you.	52
Intercept	We're sorry. The telephone you are calling from is not in service at this time.	53
Intercept	We're sorry. Your call cannot be completed as dialed. Please check the number and dial again or call your attendant to help you.	54
Intercept	We're sorry. Your call cannot be completed as dialed or the number has been disconnected. Please check the number and dial again or call your operator to help you.	55
Vacant Code	We're sorry. It is not necessary to dial a "1" when calling this number. Will you please hang up and try your call again?	56
Vacant Code	We're sorry. It is not necessary to dial a "0" when calling this number. Will you please hang up and try your call again?	57
Vacant Code	We're sorry. You must first dial a "1" when calling this number. Will you please hang up and try your call again?	58
Vacant Code	We're sorry. You must first dial a "0" when calling this number. Will you please hang up and try your call again?	59
Vacant Code	We're sorry. Your call cannot be completed as dialed from the phone you are using. Please read the instruction card or call your operator to help you.	60
Vacant Code	We're sorry. Your call cannot be completed as dialed. Please check your instruction manual or call the Business Office for assistance.	61
Vacant Code	We're sorry. Your call cannot be completed as dialed. Please check your instruction manual or call Repair Service for assistance.	62
Vacant Code	We're sorry. Your call cannot be completed as dialed. Please check the number and dial again or call your operator to help you.	63

Table K. ED-7C625-30 Announcement Modules (Contd)

SIT	Announcement	List No.
Vacant Code	We're sorry. You have dialed a number which cannot be reached from your calling area.	64
Vacant Code	We're sorry. Your call cannot be completed as dialed. Please check the number and dial again.	65
Vacant Code	We're sorry. You must first dial a "1" or "0" when calling this number. Will you please hang up and try your call again?	66
Vacant Code	911 is not a working emergency number for your area. For emergencies, hang up a moment and dial your operator.	67
Vacant Code	We're sorry. The carrier access code you dialed must be preceded by the digits 950. Please hang up and try your call again.	68
Vacant Code	We're sorry. It is not necessary to dial the digits 950 before dialing your carrier access code. Please hang up and try your call again.	69
Vacant Code	We're sorry. It is not necessary to dial a carrier access code for the number you have dialed. Please hang up and try your call again.	70
Vacant Code	We're sorry. The number you dialed cannot be reached with the carrier access code you dialed. Please check the code and try again or call your carrier for assistance.	71
No Circuit	We're sorry. All circuits are busy now. Will you please try your call again later?	72
No Circuit	We're sorry. Due to telephone company facility trouble, your call cannot be completed at this time. Will you try your call again later?	73
No Circuit	We're sorry. Because of a work stoppage, the operator will be delayed in helping you. If your call is urgent, stay on the line and the operator will answer as soon as possible.	74
Reorder	We're sorry. Your call did not go through. Will you please try your call again?	75
Reorder	We're sorry. We cannot process your custom calling request at this time. Will you try again later please?	76
—	If you'd like to make a call, please hang up and try again. If you need help, hang up and then dial your operator.	77*

* No SIT encoding precedes announcement.

Table K. ED-7C625-30 Announcement Modules (Contd)

SIT	Announcement	List No.
—	We're sorry. Due to heavy calling, we cannot complete your call at this time. Will you please hang up and try your call later? If your call is urgent, please try again now.	78*
—	We're sorry. Additional speed calling numbers cannot be entered at this time. Will you try again later please?	79*
—	We're sorry. Your call did not go through. Will you please try your call again?	80†
Inter-LATA No Circuits	We're sorry. All carrier circuits are busy now. Will you please try your call again later?	81
Inter-LATA Reorder	We're sorry. The carrier you have selected is unable to complete your call at this time. Please try your call again.	82
—	Simulates 60-IPM tone.	83
Intercept	We're sorry. Your call cannot be completed as dialed or the number has been disconnected. Please check the number and dial again	84
Intercept	We're sorry. The number you are calling cannot receive calls at this time. Please call again later.	85
Inter-LATA No Circuit	We're sorry. The long distance company you have dialed is experiencing a temporary service problem. Please try your call again later.	86
Inter-LATA No Circuit	We're sorry. The long distance company you have selected is unable to complete your call at this time. Please contact your long distance company for assistance.	87
Inter-LATA No Circuit	We're sorry. All long distance company circuits are busy now. Will you please try your call again later?	88
Inter-LATA Reorder	We're sorry. The long distance company you have selected is unable to complete your call at this time. Please try your call again.	89
Ineffective Other	We're sorry. It is not necessary to dial a "1" when calling this number. Will you please hang up and try your call again?	90
Ineffective Other	We're sorry. It is not necessary to dial "0" when calling this number. Will you please hang up and try your call again?	91

* No SIT encoding precedes announcement.

† Same as List 75, except No SIT precedes announcement.

Table K. ED-7C625-30 Announcement Modules (Contd)

SIT	Announcement	List No.
Ineffective Other	We're sorry. You must first dial a "1" when calling this number. Will you please hang up and try your call again?	92
Ineffective Other	We're sorry. You must first dial a "0" when calling this number. Will you please hang up and try your call again?	93
Ineffective Other	We're sorry. Your call cannot be completed as dialed from the phone you are using. Please read the instruction card and dial again.	94
Ineffective Other	We're sorry. Your call cannot be completed as dialed. Please check your instruction manual or call the Business Office for assistance.	95
Ineffective Other	We're sorry. Your call cannot be completed as dialed. Please check your instruction manual or call Repair Service for assistance.	96
Ineffective Other	We're sorry. The long distance company access code you dialed must be preceded by the digits 950. Please hang up and try your call again.	97
Ineffective Other	We're sorry. It is not necessary to dial the digits 950 before the long distance company access code. Please hang up and try your call again.	98
Ineffective Other	We're sorry. It is not necessary to dial a long distance company access code for the number you have dialed. Please hang up and try your call again.	99
Ineffective Other	We're sorry. You must first dial a "1" or "0" when calling this number. Will you please hang up and try your call again?	100
Ineffective Other	We're sorry. Your call cannot be completed with the access code you dialed. Please check the code and dial again or ask your long distance company for assistance.	101
Ineffective Other	We're sorry. Your call cannot be completed as dialed. Please check the number and try again or call your attendant to help you.	102
Ineffective Other	We're sorry. A long distance company access code is required for the number you have dialed. Please dial your call with the access code.	103
—	Unprogrammed (to be custom programmed to customer's specifications) for 12-second maximum announcements.	212
—	Unprogrammed (to be custom programmed to customer's specifications) for 24-second maximum announcements.	224

7. Restrictions

7.01 The following restrictions apply to the 14A:

- (a) Mount the 14A away from equipment which produces heavy electrical interference. (See Equipment Note 201 of SD-97798-01.)
- (b) Leave ventilation space, minimum 1-inch clearance, between the 14A and other equipment mounted in the frame. (See Equipment Note 202 of SD-97798-01.)
- (c) Keep the loop resistance low of the twisted pairs which connect the T and R outputs to the trunk circuits. (See Circuit Note 103 of SD-97798-01.)

8. Operation

⇒ NOTE:

The ALD2/ALD5 has a front panel mounted display which shows the operational modes available. ALD2/ALD5 also has two pushbuttons labeled MENU and SELECT. When the MENU pushbutton is pushed, the operational modes of ALD2/ALD5 are shown on the display. When the SELECT pushbutton is pressed, the operational mode shown on the display is selected. The SELECT pushbutton is also used to terminate an operational mode which was previously selected. If pressing the MENU pushbutton causes no change in what is shown on the display, press the SELECT pushbutton and then the MENU pushbutton. The various modes of operation are in paragraph 10.06.

A. Monitoring Announcements

8.01 To monitor a channel announcement on the circuit pack, perform the following:

- (1) On the ALD1, insert a G3CR-type or equivalent handset in the AUDIO MONITOR jack on the front panel of the circuit pack. Insertion of the handset plug automatically starts the announcement. The announcement will repeat as long as the handset plug is inserted (Figure 8).

On the ALD2/ALD5, using a handset with a modular plug, insert the plug into the HANDSET jack on the front panel of the circuit pack. Press the MENU pushbutton repeatedly until "LOC MON" is displayed, and then press the SELECT pushbutton. The display will show the length of the announcement and count down while the announcement is being played. To stop the announcement, press the SELECT pushbutton. The display will read "LOC MODE" (Figure 9).

**NOTE:**

This operation requires that the ALD2/ALD5 be out of service. (See Part 8D.) For installations that have the START input permanently grounded, the announcement plays continuously while the channel is in the IN-SERV mode; therefore, the announcement can be monitored by simply inserting the handset in the HANDSET jack.

- (2) Listen to the announcement. The announcement should start from the beginning and be of good audio quality.
- (3) Unplug the handset when through.

B. Measuring and Adjusting Channel Output Transmission Level in Central Office Applications

**CAUTION:**

Output level is preset to comply with FCC limits. User adjustment may void FCC registration.

**NOTE 1:**

In central office applications, it may be required that the output level be adjusted. Remove the plastic cap used to protect the adjustment by removing the pack and pushing the plastic cap from inside with a small screwdriver.

**NOTE 2:**

This operation requires that the channel be taken out of service. (See Part 8D.)

8.02 The channel output transmission level is measured on pins 20(T) and 50(R) on the 940A connector. The level is adjusted by turning the LEVEL ADJUST potentiometer through the access hole on both channel faceplates (ALD1, ALD2, or ALD5).

8.03 To measure and adjust the channel output transmission level:

- (1) Connect a 23D or equivalent transmission measuring set (TMS) directly to pins 20(T) and 50(R) on the 940A connector.

**NOTE:**

Make sure the TMS is set for the proper trunk circuit impedance, 600-ohm position for 600-ohm trunks or 900-ohm position for 900-ohm trunks. Use either setting if the channel is connected to a 2-wire telephone line via AWH1.

- (2) On the ALD1, press the SET LEVEL/NORMAL pushbutton switch on the faceplate. The SET LEVEL/NORMAL LED lights (Figure 8) and a steady 1000-Hz reference tone is generated by the circuit pack for detection by the TMS.
- On the ALD2/ALD5, press the MENU pushbutton repeatedly until "SET LEV" is displayed, and then press the SELECT pushbutton. The display will read "ADJ LEV" and a steady 1000-Hz reference tone for detection by the TMS will be generated.
- (3) Read the output transmission level on the TMS (Table L).

Table L. Output Transmission Levels for TMS (Note)

Type of Connection	Preferred Reading	
	ALD1	ALD2/ALD5
600-Ohm Trunk	-2 dBm	-8 dBm
900-Ohm Trunk	-2 dBm	-8 dBm
2-Wire Telephone Line via AWH1	0 dBm	-6 dBm

Note: The TMS is connected directly to pins 20 and 50 of the 940A connector on the 14A mounting plate.

- (4) Adjust the LEVEL ADJUST potentiometer (if necessary) with a small standard screwdriver until the TMS reads the preferred level shown in Table L. These preferred levels will result in a transmission level to the network of -24 dBm for the SIT tones and -22 VU for the announcement. Table M shows the equivalent rms voltage levels if a high impedance voltmeter is used instead of a TMS.

Table M. Output Transmission Levels for Voltmeter (Note)

Type of Connection	Preferred Reading	
	ALD1	ALD2/ALD5
600-Ohm Trunk	0.615 V rms	0.308 V rms
900-Ohm Trunk	0.754 V rms	0.378 V rms
2-Wire Telephone Line via AWH1	0.775 V rms	0.388 V rms

Note: The TMS is connected directly to pins 20 and 50 of the 940A connector on the 14A mounting plate.

- (5) On the ALD1, press the SET LEVEL/NORMAL pushbutton switch to NORMAL when through adjusting. The SET LEVEL/NORMAL LED goes off.
On the ALD2/ALD5, press the SELECT pushbutton to escape the ADJ LEV function. The display will read "LOC MODE."
- (6) Monitor the announcement. (See Part 8A.) If satisfactory, remove the TMS.
- (7) Place the channel in service. (See Part 8C.)

C. Placing a Channel In Service (Announcement Mode)

⇒ NOTE:

When a 14A channel is placed in service, it will only provide signaling and the announcement to the appropriate trunk group. Local office procedures should be followed to ensure that a subscriber is switched to that announcement when required.

8.04 To place a channel in service:

- (1) ALD1 is automatically placed in service when the handset used to monitor the announcement is removed and the SET LEVEL or the VOICE ALARM LED is not lit.
To place the ALD2/ALD5 in service, press the MENU pushbutton repeatedly until "IN-SERV" is displayed. Press the SELECT pushbutton. The display will read "IN-SERV."
- (2) The announcement plays whenever a closure occurs between connector pins 26 (START) and 5 (START RET). When the announcement plays on an ALD2/ALD5, the display reads "ANNOU/ANN," shows the announcement length in seconds for the ALD2 and in minutes and seconds for the ALD5, and counts down until the announcement ends. During the 1-second CUT-THRU interval, the display will read "IN-SERV."

D. Taking a Channel Out of Service

⇒ NOTE:

When a 14A channel is taken out of service, no signaling or announcement is provided to the appropriate trunk group. Therefore, the announcement will not be available to a subscriber when required. This action may also generate a central office alarm. Therefore, local office procedures should be followed before taking a 14A channel out of service.

8.05 To take a channel out of service, perform the following:

- (1) ALD1 is taken out of service by removing the circuit pack from the housing. (See Part 8E.) Pressing the SET LEVEL/NORMAL switch, lighting the SET LEVEL/NORMAL LED, will cause ALD1 to be out of service.

⇒ NOTE:

If the display on an ALD2/ALD5 shows "REM MODE," ALD2/ALD5 is being accessed by the remote record circuit and cannot be removed from service at this time.

To take an ALD2/ALD5 out of service, press the SELECT pushbutton. If the announcement is playing, the announcement continues until it ends. When ALD2/ALD5 is out of service, the display will flash on and off "LOC MODE," the VOICE ALARM LED will light, and a voice alarm will be generated. This is a precautionary feature to avoid accidentally removing ALD2/ALD5 from service by inadvertently pressing the SELECT pushbutton. To clear the voice alarm condition, press the MENU pushbutton. The display will read a steady "LOC MODE," and the VOICE ALARM LED will extinguish. ALD2/ALD5 can be removed from the housing at this time. (See Part 8E.)

E. Removing and Installing ALD1, ALD2, and ALD5 Circuit Packs

▲ CAUTION:

ALD1, ALD2, and ALD5 contain integrated circuits which are electrostatically sensitive. Use grounding straps or other protective measures when handling these circuit packs.

⇒ NOTE:

Follow local procedures first to remove the channel from service. (See Part 8D.) Before you remove an ALD2/ALD5 from the rack, if required, record the peg count. (See Part 8I.)

8.06 To remove and install either circuit pack, perform the following:

- (1) Pull the spring-loaded latch located on the right side of the pack forward and hold it there (Figures 8 and 9).
- (2) Pull the circuit pack forward and out of the apparatus mounting. (No electrical damage will be caused to an ALD1, ALD2, or ALD5 by removing or inserting it with power on.)
- (3) If the plug-in announcement module on the ALD1 is to be installed or removed, see Part 8G.

▲ CAUTION:

Do not place an ALD2/ALD5 circuit pack on a conductive surface or in a conductive bag. The battery that retains the announcement in the memory will discharge and the announcement will be lost.

- (4) Before installing a new ALD2/ALD5 circuit pack in the 14A, check that the memory backup battery is installed in the battery socket. (See Part 9C and Figure 11 for the ALD2 and Figure 12 for the ALD5.)
- (5) Place the removed circuit pack or its replacement in the apparatus mounting tracks and slide it forward until it is fully mated with the 940A connector. Hold the spring-loaded latch forward until the pack is fully mated. Release the latch and check if it is in the latched position. (Diagnostics will be automatically run on the 14A.)
- (6) When an ALD2/ALD5 circuit pack is installed, the display will first read "STAND BY." During this time, a diagnostic test is being run. If the diagnostic test passes, the display will read "LOC MODE." If the display flashes on and off RECORD, a voice alarm will be generated. This indicates that the announcement memory contains no speech data and a recording must be made before the ALD2/ALD5 will operate. Press the SELECT pushbutton. The voice alarm will clear, the display will stop flashing, and the display will read "SIT SEL." At this time, a recording must be made. (See Part 8H.)

⇒ NOTE:

If the display is flashing "RECORD," and the recording is to be made from a remote location, press the SELECT pushbutton. The display will read "SIT SEL." Then press the MENU pushbutton repeatedly until the display reads "LOC MON." This action clears the voice alarm and makes the ALD2/ALD5 ready for programming by the remote record circuit. If the display shows "LOC MODE," no action is required.

- (7) If the diagnostic test fails, the display will flash on and off "ROM FAIL" or "AUD FAIL." (See Part 10A.)

⇒ NOTE 1:

Since both packs have their own power supply, they may be installed with the -48 V supplied to the system.

⇒ NOTE 2:

When an ALD1 is installed and the 14A is powered up, the VOICE ALARM and MEMORY FAILURE LEDs light for approximately 1 second and then extinguish. If the LEDs fail to light at this time, check the fuse in the -48 V battery supply to the 14A Announcement System.

- (8) Measure and adjust the channel output transmission level. (See Part 8B.)

⇒ NOTE 1:

It should not be necessary to readjust the output transmission level on the ALD1 or ALD2/ALD5 unless it is replaced by a spare that has not been previously adjusted. Also, it should not be necessary to readjust the output transmission level on an ALD1 if only the plug-in announcement module is being replaced on an ALD1 that has previously been adjusted.

⇒ NOTE 2:

If the message on an ALD2/ALD5 is to be changed, record the peg count. Each time you record a new announcement, the ALD2/ALD5 zeroes the counter.

F. Removing and Installing AWH1 Circuit Pack

8.07 To remove and install an AWH1 circuit pack, perform the following:

- (1) Pull the latch located on the right side of the AWH1 forward and hold it.
- (2) Pull the AWH1 circuit pack forward and out of the apparatus mounting. (No electrical damage will be caused to the AWH1 by removing or inserting it with power on.)
- (3) Place the AWH1 with the latch open in the apparatus mounting tracks and slide it forward until the latch engages the latch spring. Press the latch handle forward until the circuit pack is fully mated with the AMP 5-530396-0 connector.

G. Installing and Removing Plug-In Announcement Module

▲ CAUTION:

The 14A Announcement Modules are electrostatically sensitive. Use grounding straps or other protective measures when handling these modules. Also, be careful not to damage any electronic components on the ALD1 adjacent to the announcement module.

8.08 To install the plug-in announcement module, perform the following:

⇒ NOTE:

The following operations can be performed with the ALD1 pulled halfway out of its apparatus mounting.

- (1) Grip module between thumb and index finger as shown in Figure 10. The EPROM should be facing away from the installer.
- (2) Slide module onto the connector on the ALD1.
- (3) With the ALD1 supported by the other hand, slide the module firmly into the connector until fully mated. A little side-to-side motion is helpful in overcoming the resistance encountered while the module is mating with the connector.

⇒ NOTE:

The connector is polarized and the module can be installed only in the correct position.

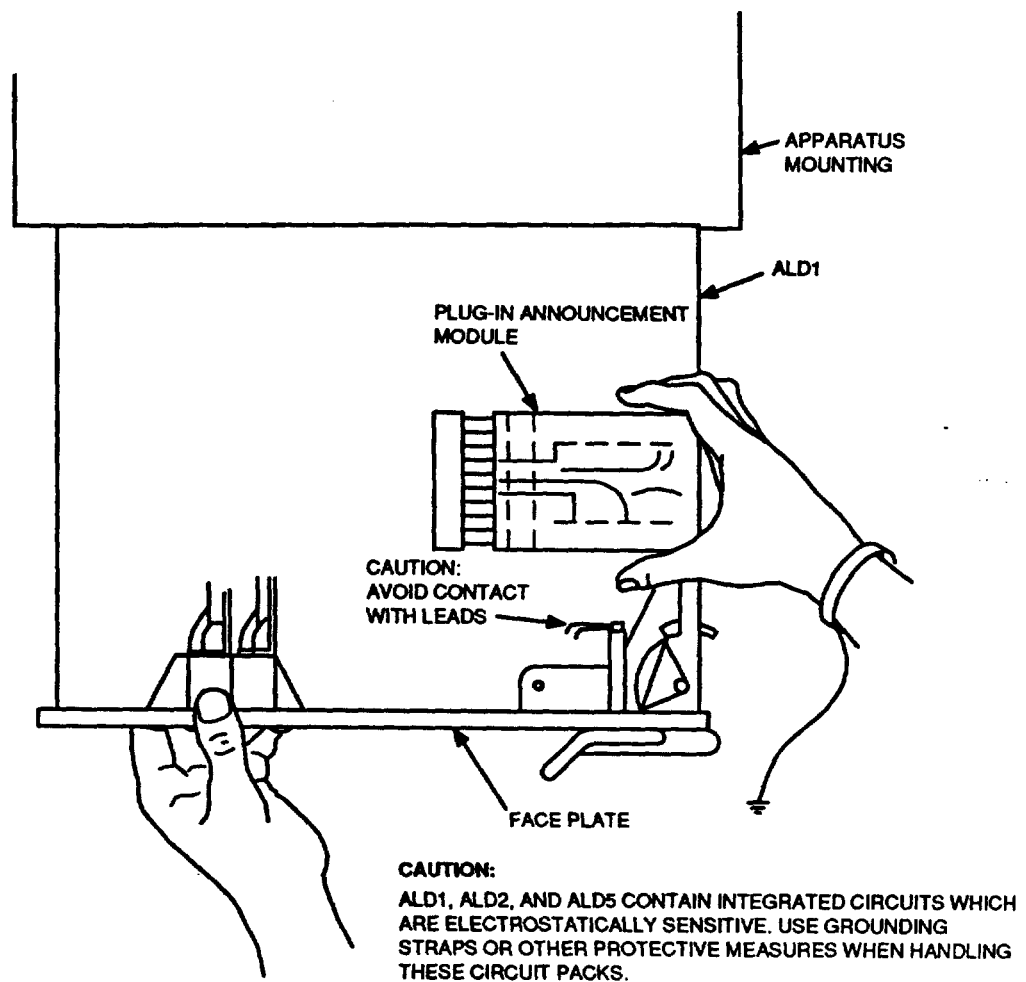

Figure 10. Installation and Removal of Plug-In Announcement Module

8.09 To remove an installed plug-in announcement module, perform the following:

- (1) Grip module between thumb and index finger as shown in Figure 10.
- (2) With the ALD1 supported by the other hand, gently pull the module to the right. A little side-to-side motion is helpful in overcoming the resistance encountered while the connector is mated with ALD1.

H. Installing an Announcement in the ALD2/ALD5 Circuit Pack

⇒ NOTE:

This operation requires that the channel be taken out of service. (See Part 8D.)

8.10 To install or change the announcement on an ALD2/ALD5 circuit pack (Figure 9), perform the following:

- (1) If a SIT is required to precede the announcement, press the MENU pushbutton repeatedly until "RECORD" appears in the display, and then press the SELECT pushbutton. The display will read "SIT SEL." Press the SELECT pushbutton. The display will read "INTERCEPT." This is the first SIT that ALD2/ALD5 can generate. If this is the required SIT, press the SELECT pushbutton. If not, press the MENU pushbutton repeatedly until the display shows the required SIT (see Table G), and then press the SELECT pushbutton. After the SIT has been selected, the display will read "30S REC" for the ALD2 and "2:00 REC" for the ALD5. The ALD2/ALD5 is ready to record.

⇒ NOTE:

There are 32 SIT combinations available; however, only 7 have been defined to date. Any of the numbered SITs (8 to 32) may be defined in the future. A newly defined SIT can be selected by pressing the SELECT pushbutton when the display shows the number which corresponds to the required SIT. (See Table G.)

- (2) If a SIT is not required or the SIT will be recorded from a tape recorder, press the MENU pushbutton repeatedly until "RECORD" appears on the display. Press the SELECT pushbutton. The display will read "SIT SEL." Press the MENU pushbutton. The display will read "30S REC" for the ALD2 and "2:00 REC" for the ALD5. The ALD2/ALD5 is ready to record.
- (3) If the announcement is to be recorded live, using a handset with a modular plug, insert the plug into the HANDSET jack on the front panel of the circuit pack. Press the SELECT pushbutton to start the recording process, and then immediately speak into the handset using a normal voice. While the ALD2 is recording, the display will count down from 30 seconds in 1-second increments. When the display countdown reaches 0, the recording ends yielding an announcement of 30 seconds in length. For announcements of less than 30 seconds, the recording is stopped by pressing the SELECT pushbutton. When the recording ends, the display will read "REC END."

For the ALD5, the operation is similar but it starts counting down from 2:00 minutes in 1-second increments, yielding a maximum recording length of 2 minutes.
- (4) If the announcement is to be recorded via tape, insert the plug of the cord from the tape recorder into the TAPE jack. Adjust the playback level of the tape recorder to a comfortable listening level. (Recommended level is -10 VU.) Set the recorder on PLAY and start the tape recorder; then immediately press the

SELECT pushbutton to start the announcement recording process. While the ALD2 is recording, the display will count down from 30 seconds in 1-second increments. When the display countdown reaches 0, the recording ends, yielding an announcement of 30 seconds in length. For announcements of less than 30 seconds, the recording is stopped by pressing the SELECT pushbutton. When the recording ends, the display will read "REC END."

For the ALD5, the operation is similar but it starts counting down from 2:00 minutes in 1-second increments, yielding a maximum recording length of 2 minutes.

⇒ NOTE:

Maximum duration of an announcement is 30 seconds for an ALD2 and 2 minutes for an ALD5.

- (5) Monitor the announcement (Part 8A). The announcement should start from the beginning and be of good audio quality.
- (6) Unplug the handset when through.
- (7) If required, set the transmission level. (See Part 8B.)

I. Reading ALD2/ALD5 Peg Count

⇒ NOTE:

This operation requires that the channel be taken out of service. (See Part 8D.)

8.11 To read the peg count of the present announcement on the ALD2/ALD5 circuit pack, perform the following:

- (1) If the ALD2/ALD5 is in service, press the SELECT pushbutton to take the channel out of service. (See Part 8D.)
- (2) Press the MENU pushbutton repeatedly until "PEG CNT" appears in the display, and then press the SELECT pushbutton. The ALD2/ALD5 shows numerically the actual number of times that the recorded announcement has played while it was in service.
- (3) If the ALD2/ALD5 is to be placed in service, see Part 8C.

9. Maintenance

9.01 Since the 14A Announcement System is completely electronic, no routine maintenance is required. An on-board microcomputer routinely diagnoses the circuitry and signals alarms when a hard fault is discovered.

A. Checking the Memory Backup Battery on ALD2/ALD5

9.02 The memory backup battery on ALD2/ALD5 prevents the loss of the data stored in the announcement memory when power to 14A is interrupted. In normal operation, the battery will not become discharged. However, if the ALD2/ALD5 is unpowered for long periods of time (several years cumulative), the battery will eventually discharge and the data in the announcement memory will be lost. In order to check the battery, the ALD2/ALD5 must first be removed from the housing. (See Part 8E.) Place the ALD2/ALD5 on a nonconductive surface with the faceplate facing to the right. Locate pins 32 and 16 of the announcement memory. (See Figure 11 for the ALD2 and Figure 12 for the ALD5.) Using a battery operated DC voltmeter, measure the voltage between pin 32 (+) and pin 16 (-) of the announcement memory. If the voltmeter reads less than 2.00 V DC, the battery should be replaced.

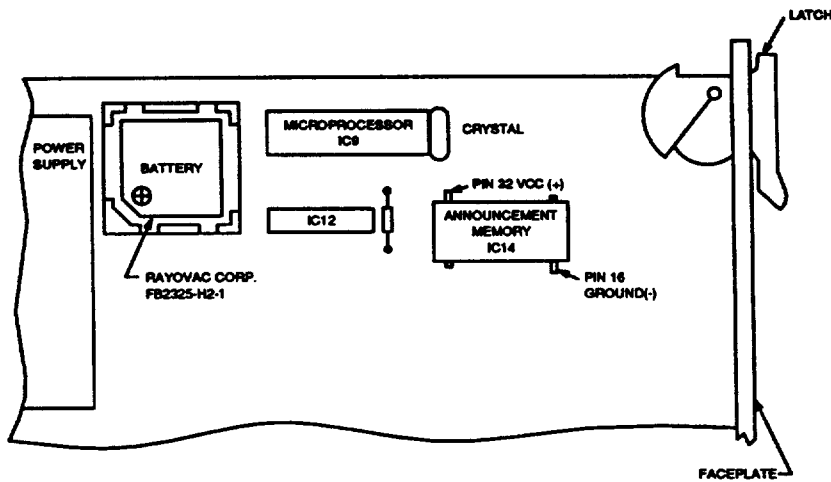

Figure 11. Locating Backup Battery and Announcement Memory on ALD2

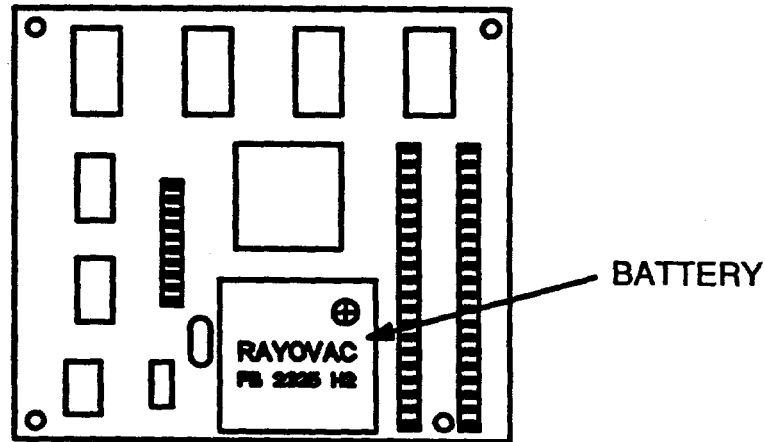

Figure 12. Locating Backup Battery and Announcement Memory on ALD5

B. Removing the Memory Backup Battery

9.03 Using a small screwdriver, pry the battery from the socket until it snaps free from the molded grips. The battery can then be removed from the socket.

⇒ NOTE:

When the memory backup battery is removed from the battery socket, the data in announcement memory will be lost. Therefore, after installing a new battery and installing the ALD2/ALD5 in the 14A housing, the announcement for that channel must be recorded. (See Part 8H.)

C. Installing the Memory Backup Battery

9.04 Orient the battery such that the positive (+) indicator on the battery is over the positive indicator (+) of the socket. Visually verify that all battery pins are straight. The battery notch will help orient the battery correctly. Place the battery in the socket without forcing it. The battery pins should be aligned with the socket receptacles. With a finger placed in the center of the battery, apply enough force to drive the battery past the molded grips so that it locks into place. If the battery fails to lock in place, one or more of the pins have become bent. Use small pliers to straighten the bent pins and reinsert the battery in the socket. Replacement battery is available from the Rayovac Corporation as part number FB2325-H2-1. The -1 code is used to request individual battery packaging which protects the pins from shorting out if improperly handled.

10. Trouble Analysis

10.01 Due to routine diagnosis by the on-board microcomputer, trouble detectors, analysis, and connection in the 14A Announcement System is simplified. Troubles are indicated by system alarms, output messages, displayed messages, and lighted indicators on the 14A. Careful analysis of these indicators can help locate the trouble area. Once the trouble area is located, most problems are solved by replacing the circuit pack or the announcement module on the ALD1.

⇒ NOTE:

A loss of power to the 14A Announcement System will generate a central office alarm condition that is not indicated by lighted LEDs. If the 14A does not operate and the LEDs are not lighted, check the fuse in the -48 V battery supply. If the fuse is blown, replace it. If it blows again, replace the circuit pack(s) (ALD1 or ALD2/ALD5).

10.02 The most common troubles and trouble clearing flowcharts for the ALD1 are listed in Table N.

Table N. ALD1 Trouble Clearing

Trouble	Comment	Flowcharts
VOICE ALARM LED lighted (only)	Announcement may not be present.	Figure 13
MEMORY FAILURE LED and VOICE ALARM LED lighted (both)	Announcement may be present, but it may be garbled.	Figure 14

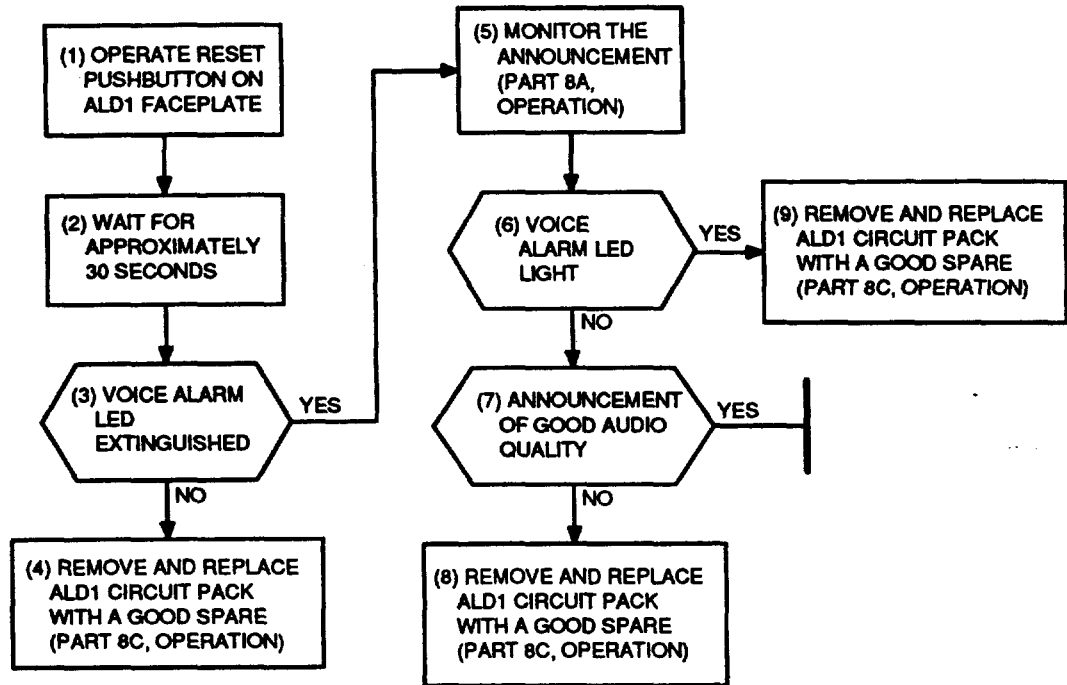

Figure 13. ALD1 Voice Alarm LED Flowchart

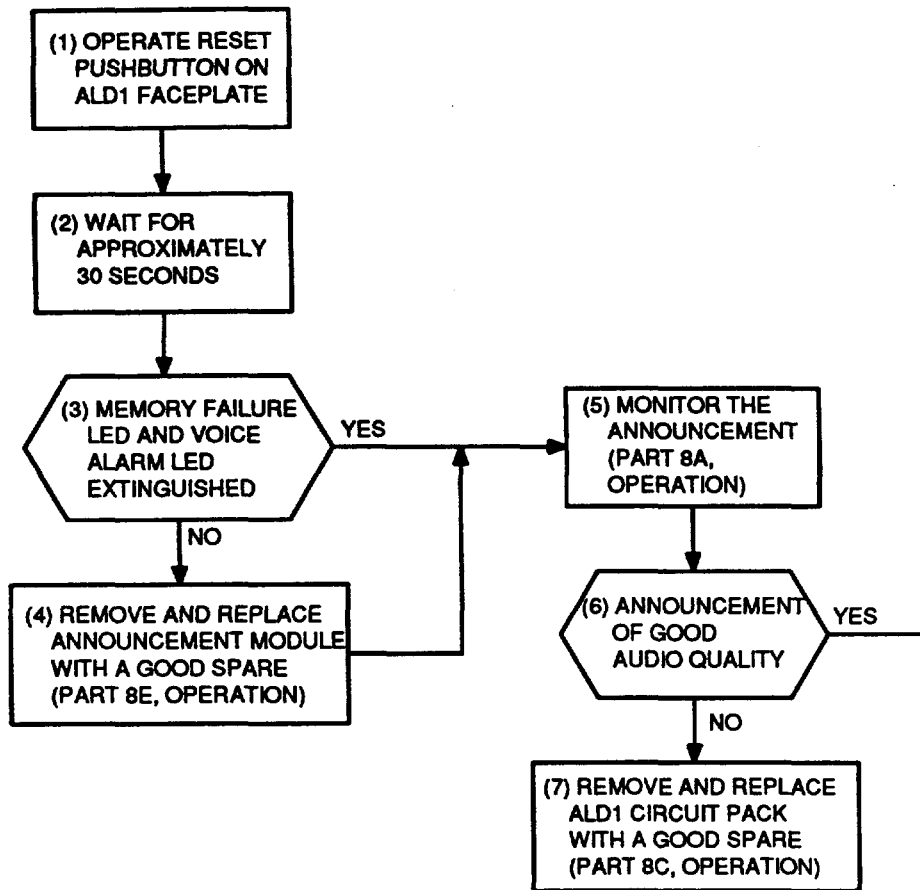

Figure 14. ALD1 Memory Failure LED and Voice Alarm LED Flowchart

10.03 When a routine diagnostic test detects a malfunction on the ALD2/ALD5, the display shows the type failure detected by flashing on and off the nature of the failure. (See Table O.) A failure of the microcomputer or the loss of power to an ALD2/ALD5 will cause the display not to function; however, a voice alarm will be generated. A malfunction of ALD2/ALD5 may have been caused by some temporary disturbance. Therefore, a diagnostic test of ALD2/ALD5 should be made any time a voice alarm condition occurs.

⇒ NOTE:

If ALD2/ALD5 detects a malfunction while being accessed by the remote record circuit, a voice alarm will be generated, and the display will flash "REM MODE."

Table O. ALD2/ALD5 Display Trouble Messages

Flashing Display Shows	Meaning	Action to Take
REM MODE	Remote record failure	Check if Connector Pin 8 is shorted to Ground Pin 7. (See previous Note.)
DSP FAIL	Display failure	Replace ALD2/ALD5 (optional).
ROM FAIL*	Microcomputer failure	Replace ALD2/ALD5.
AUD FAIL*	Audio circuit failure	Check position of LEVEL ADJUST potentiometer. See Part 8B, Step (4).
RAM FAIL*	Announcement memory failure	Record an announcement. See Part 8H.

*Generates a voice alarm.

A. Diagnostic Test of ALD2/ALD5

10.04 Press the MENU pushbutton repeatedly until "CHK SYS" appears on the display. Then press the SELECT pushbutton. A complete diagnostic test of ALD2/ALD5 is started. The first test is a visual check of the display. All the display LEDs are illuminated in a pattern which first illuminates the even numbered LEDs for 2 seconds and then illuminates the odd numbered LEDs for 2 seconds. The display is off for an instant and then will read "STAND BY." When the diagnostic test is completed, the display will read "LOC MODE" if the diagnostic test passes.

10.05 The trouble clearing steps for the ALD2/ALD5 are as follows:

- (1) If the diagnostic test detects a malfunction, the malfunction will be shown by the display. See Table O for the meaning and possible corrective action.
- (2) To return to normal operation and to clear any voice alarms, press MENU. The display will read "LOC MODE." Take the appropriate action (Table O) and repeat the diagnostic test of ALD2/ALD5.
- (3) A failure of the display will not affect the announcement operation of an ALD2/ALD5; therefore, replacing an ALD2/ALD5 because of a display failure is optional.
- (4) If the remote record capability of ALD2/ALD5 is not used and a remote record failure occurs, ALD2/ALD5 will function normally and will not have to be replaced.
- (5) If a repeated diagnostic test detects a malfunction which generates a voice alarm, the ALD2/ALD5 circuit pack must be replaced.

10.06 The most common messages displayed by the ALD2/ALD5 during a menu selection process are listed in Table P.

Table P. ALD2/ALD5 Menu Display Messages

Message	Comment
ADJ LEV	Allows adjustment of the output transmission level using a 1-kHz reference tone (see Part 8B).
CHK SYS	When selected, a complete diagnostic test of ALD2/ALD5 is made.
IN-SERV	Indicates that the circuit pack is in service. When the unit receives a ground start, it starts sending the announcement.
LOC MODE	Indicates that the unit has been removed from service and is in local mode.
LOC MON	Indicates that the unit has been removed from service and is in the monitor mode.
PEG CNT	Allows the processor to display from memory the actual number of times the announcement was broadcasted while the channel was in the IN-SERV mode, when the SELECT pushbutton is pressed.
RECORD	Indicates the RECORD function may be selected by pressing the SELECT pushbutton.
REM MODE	Indicates that the ALD2/ALD5 is being accessed by the remote record circuit.
SET LEV	Indicates that the transmission level of the circuit pack may be adjusted after the SELECT pushbutton is pressed (see Part 8B).
SIT SEL	Indicates that the SIT preceding an announcement can be generated internally if desired by technician.
STAND BY	Indicates that the processor is performing a diagnostic test on the circuit.
30S REC/ 2:00 REC	Indicates that the RECORD mode has been selected and the internal timer is ready to be started to time the announcement being recorded. (Announcement length is 30 seconds maximum for ALD2 and 2.00 minutes maximum for ALD5.)
30S MON/ 2:00 REC	Indicates that the Local Monitor Mode has been selected and the announcement may be monitored from a handset.