

**CENTRAL CONTROL CIRCUIT, SD-5G142-01**  
**DESCRIPTION AND OPERATION**  
**CABLE PRESSURE TELEMETRY SYSTEM**

CONTENTS	PAGE
1. GENERAL . . . . .	1
2. DESCRIPTION . . . . .	2
3. TYPICAL OPERATION . . . . .	8
4. ALARMS . . . . .	11
<b>Figures</b>	
1. Central Control Bay . . . . .	2
2. Current and Cable Select Panel . . . . .	3
3. KS-16100,L7 Timer Panel . . . . .	4
4. Control Panel Interface . . . . .	4
5. Print and Control Panel . . . . .	4
6. Part of Central Control Panel Showing Digital Volt-Ohmmeter and Thermal Printer . . . . .	5
7. Part of Central Control Panel Showing ISBC-655 System Chassis (Intel Corporation) . . . . .	6
8. Program Select Panel . . . . .	6
9. Fuse Panel . . . . .	6
10. Precharge Sensing Panel . . . . .	6
11. D-Transducer Measurement . . . . .	7
12. Cable Pressure Measurement Time Sequence . . . . .	8
13. Sample Printout . . . . .	10
14. FD-5G061-30, G1 Card Shelf Showing Position of Circuit Packs . . . . .	13

**1. GENERAL**

- 1.01** This section describes the central control circuit, SD-5G142-01, and its operation as part of the Cable Pressure Telemetry System (CPTS).<sup>4</sup>
- 1.02** This section is reissued for the reasons listed below. Revision arrows have been used to highlight significant changes.
- (a) To change the title to read "Central Control Circuit, SD-5G142-01—Description and Operation—Cable Pressure Telemetry System"
  - (b) To change paragraph 1.01 to agree with the title
  - (c) To add paragraph 1.03 covering the central control unit equipment bay
  - (d) To add paragraph 1.04 which contains references to associated Bell System Practices (BSPs)
  - (e) To change paragraph 2.12 (c) to describe the operation with ZN option and (f) to describe the operation of the proper keys for halting the continuous printing of the same station
  - (f) To add paragraphs 3.08 through 3.12 describing the modified central control unit (SD-5G142-01, ZN option) which provides for the addition of a microcomputer and the replacement of the impact printer with a thermal printer
  - (g) To change the numbering of Fig. 1 through 3 to Fig. 11, 5, and 12, respectively, and to change the location of some keys in the new Fig. 5
  - (h) To add new Fig. 1 through 4, 6 through 10, 13, and 14 showing the various apparatus associ-

**NOTICE**

Not for use or disclosure outside the  
Bell System except under written agreement

## SECTION 201-610-301

ated with the central control circuit and a sample printout (Fig. 13) of the thermal printer.

**1.03** The apparatus associated with the central control circuit is mounted on a portion of one equipment bay (Fig. 1). Figures 2 through 10 and 14 show the pieces of apparatus that are mounted on the equipment bay.

**1.04** Section 637-080-100 covers the description and operation of the B-(dummy) and D-pressure transducers used with this system. Additional BSPs associated with the CPTS are:

- Section 106-020-135—description of the D-pressure transducer
- Section 201-610-301—trouble locating procedures
- Section 201-610-311—description, operation, and maintenance of both the impact and the thermal printers
- Section 201-610-501—central control test procedures.

## 2. DESCRIPTION

**2.01** The central control circuit commands a D-transducer location to read the pressure in the cable at a particular location. The pressure is then read into the central control memory circuit where it is compared with a reference value. When alarm conditions exist, pressures at all transducers on the alarmed cable are printed out.

**2.02** By means of this pressure gradient of the cable, it is possible to detect and approximate sheath faults that might lead to a service interruption.

**2.03** The D-transducer contains a pressure to the resistance transducer and relays for controlling the connection of the transducer to the control circuit. The central control measures the resistance of the transducer by applying a constant current to a pair of wires connected to the transducer. The voltage at the terminal of the constant current supply is proportional to the resistance of the transducer. The resistance and the value of the current are chosen so that one volt corresponds to one pound of pressure.

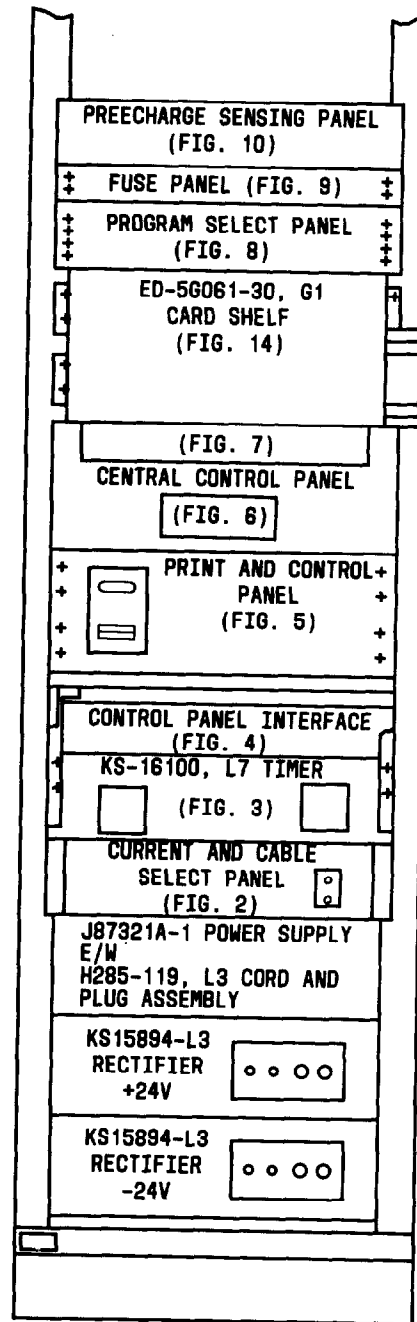

Fig. 1—Central Control Bay

**2.04** Two measurements are made to compensate for the loop resistance of the cable. Figure 11 illustrates the measurement procedure. The first measurement is made with relays A and B normal. This measurement reads the voltage across the loop (resistance CR1) and the resistance of pressure

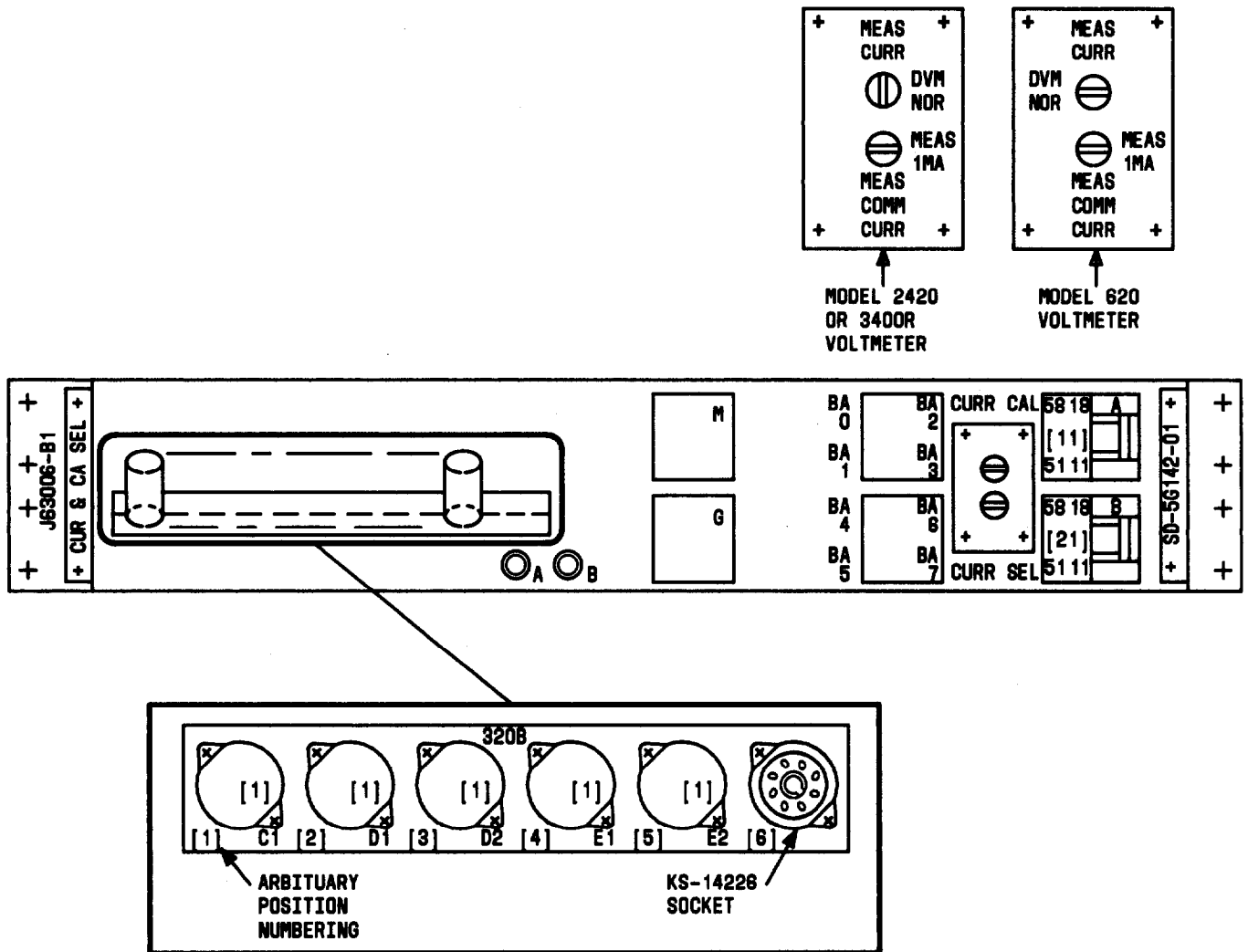

Fig. 2—Current and Cable Select Panel

transducer station 1. The central control then issues a command which operates the A relay in transducer station 1. The voltmeter now reads the voltage across only the loop (resistance CR1) since the pressure transducer is shorted. The central control then subtracts the second measurement from the first. The difference is the voltage across the pressure transducer resistor only, and therefore proportional to the pressure.

**2.05** After completing the second measurement, the central control issues a command which

operates relay B in transducer station 1. The central control then reads the pressure in transducer station 2. This process is continued until all transducers are read.

**2.06** Before any new measurements of this cable are made, commands are sent to release all A and B relays which restore all transducers to normal.

**2.07** Alarm signals are generated, and a printout of the pressure of all transducers on the cable

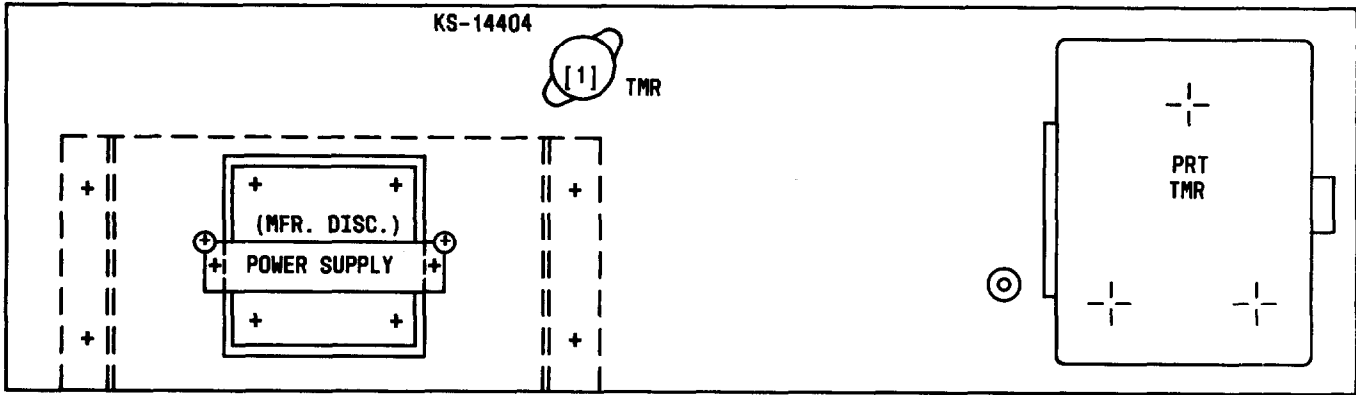

Fig. 3—KS-16100,L7 Timer Panel

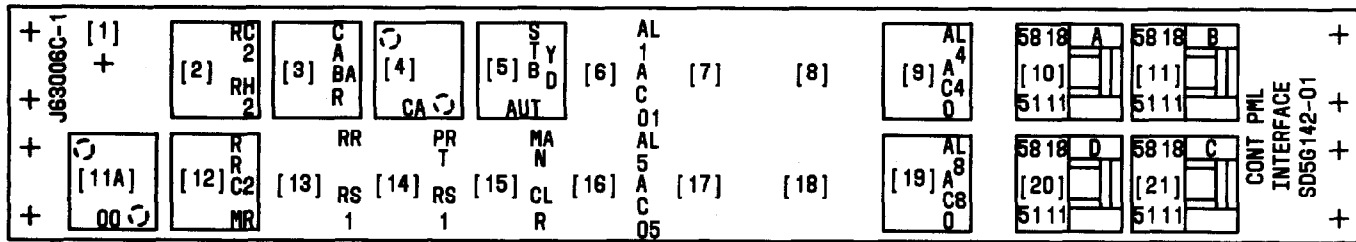

Fig. 4—Control Panel Interface

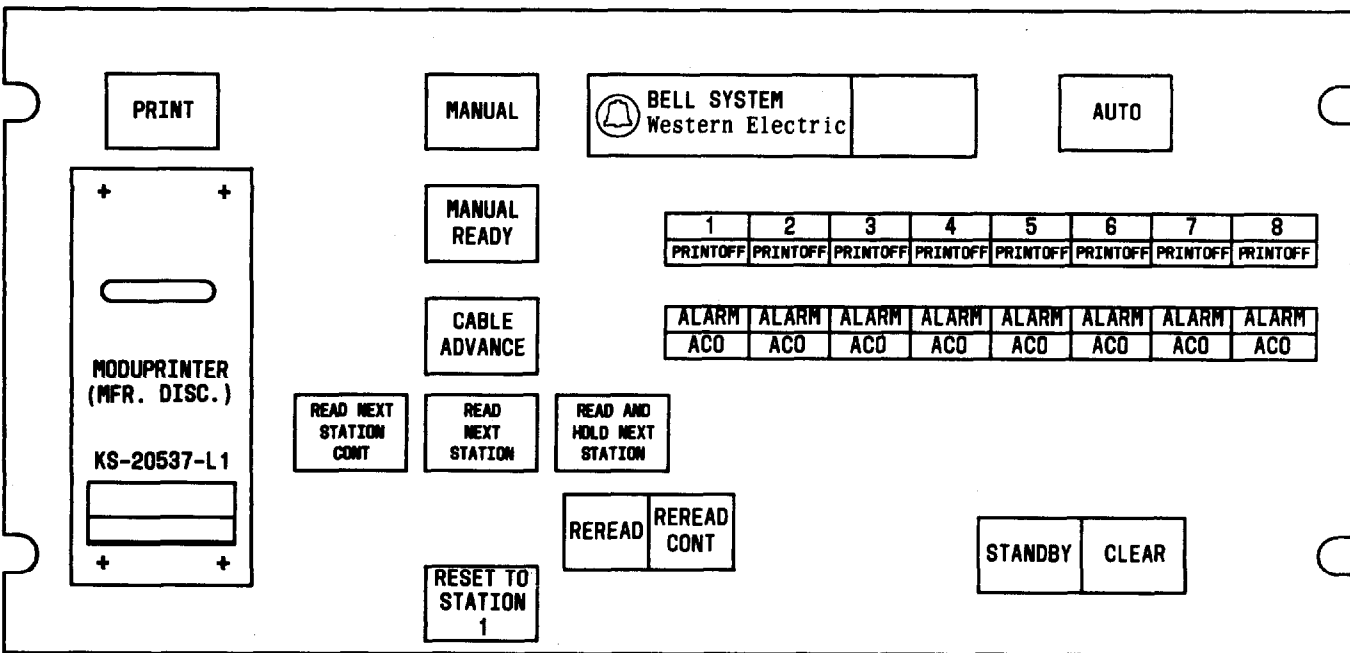
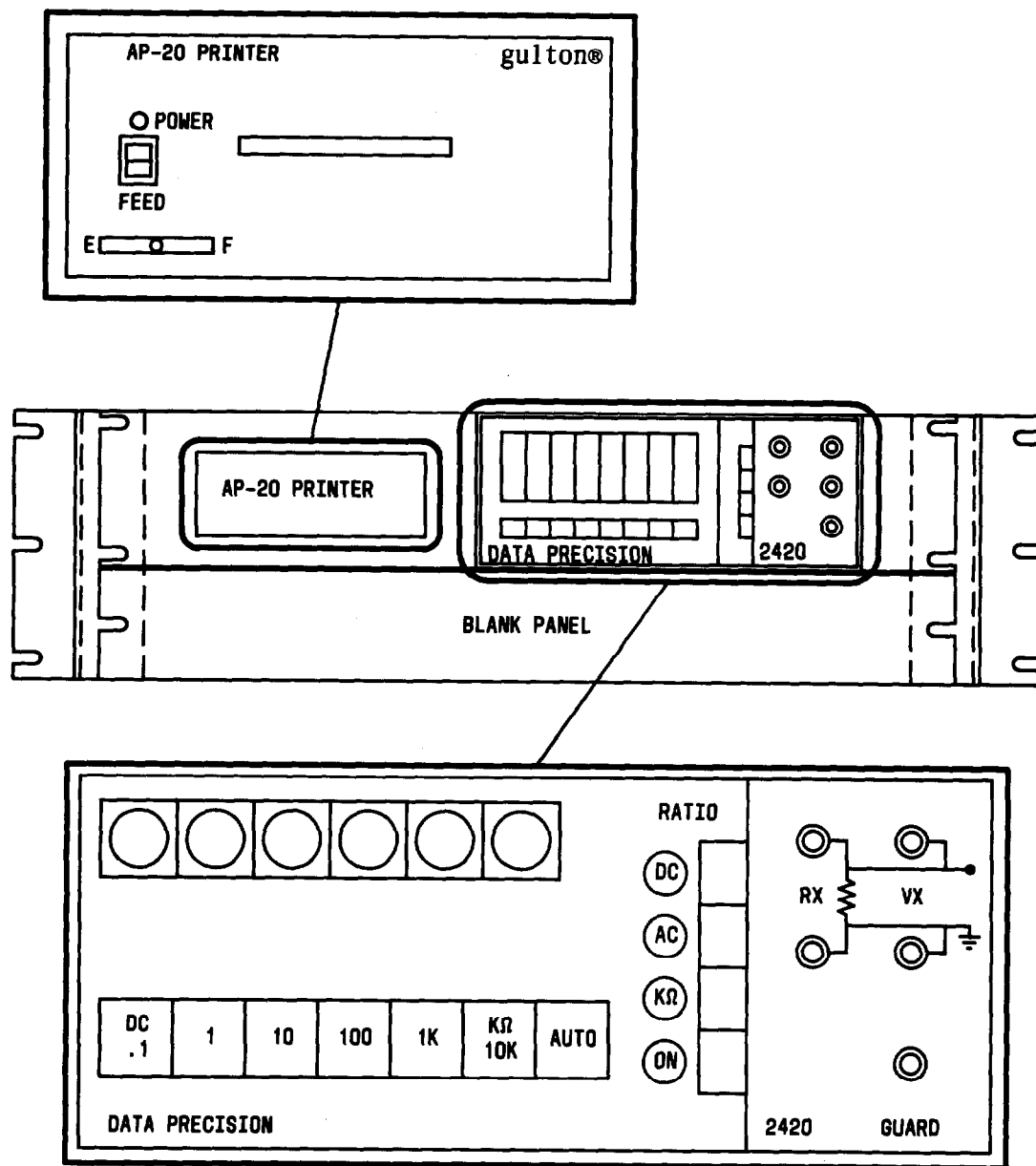

Fig. 5—Print and Control Panel



▶Fig. 6—Part of Central Control Panel Showing Digital Volt-Ohmmeter and Thermal Printer◀

being scanned is made if the pressure at any transducer falls below a predetermined level.

**2.08** The different operational modes can be activated from the central control unit control panel (Fig. 5).

**2.09** The automatic mode is activated when the **AUTO** key is operated and scanning is started

on a continuous basis for a maximum of eight cables. The cable being scanned at any instant is indicated by a lighted cable number lamp (1 to 8) on the control panel. The pressure readings are obtained as described in Parts 3 and 4 and are compared with the programmed alarm levels. If the pressure is within the required limits, the printer will remain normal at this time.

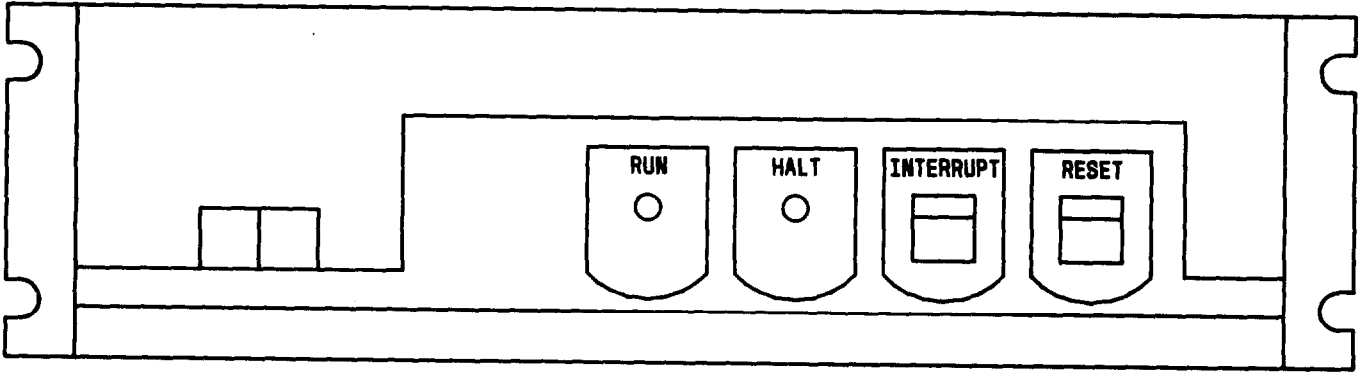

◆Fig. 7—Part of Central Control Panel Showing ISBC-655 System Chassis (Intel Corporation)◆

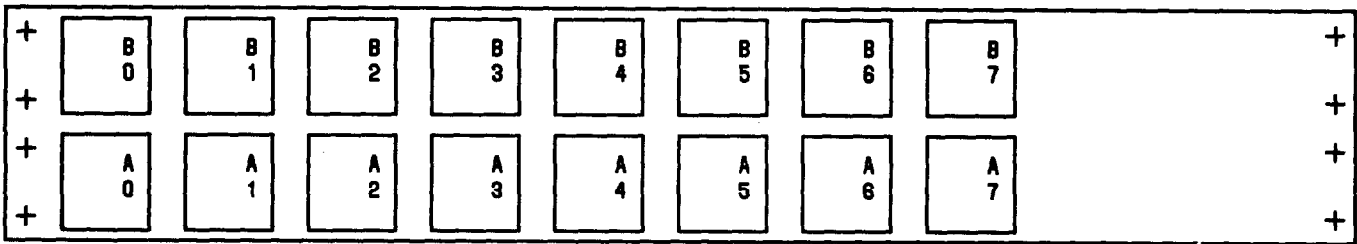

◆Fig. 8—Program Select Panel◆



◆Fig. 9—Fuse Panel◆

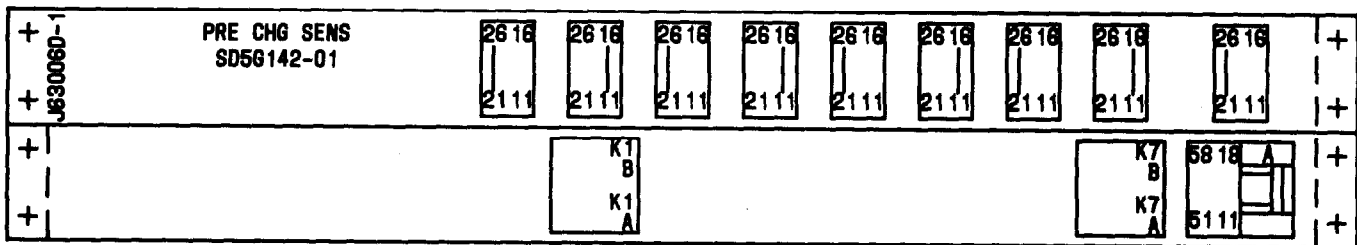

◆Fig. 10—Precharge Sensing Panel◆

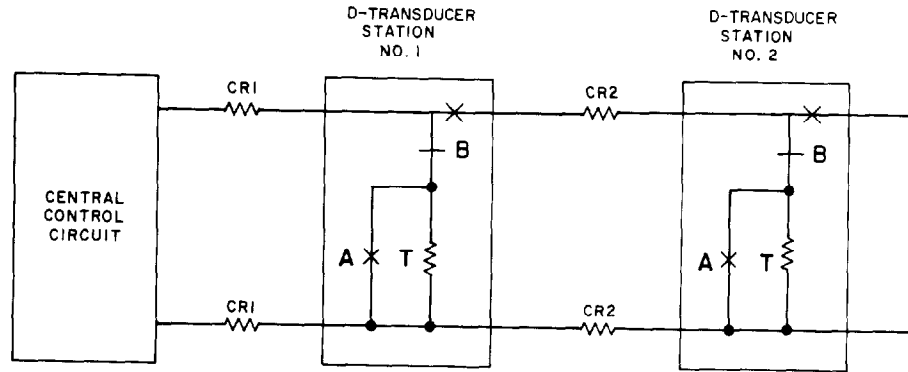

Fig. 11—D-Transducer Measurement

**2.10** If an alarm condition is detected, the office alarms will be activated and a red ALARM lamp associated with the defective cable will be lighted. When an alarm is received, the system continues to scan to the end of the cable without a printout. The system then initiates a complete rescan on that cable with a printout of the pressure of all the transducers on the alarmed cable, instead of advancing to the next cable. At the termination of this scan the control circuit advances to the next cable, repeating the sequence for each cable.

**2.11** The manual mode of operation can be initiated at any time. Operation of the MANUAL key stops the automatic mode of operation, causes the MANUAL lamp to flash at a 1-second rate, extinguishes the AUTO lamp, and at the completion of the operation in progress lights the MANUAL READY lamp. When in the manual mode, the MANUAL READY lamp must be lighted before any manual operations are executed (except CABLE ADVANCE and RESET TO STATION 1). All readings will be printed out when in the manual mode.

**2.12** The following keys when operated activate the central control circuit as described:

- (a) **ALARM/ACO:** If an alarm occurs on a cable and the corresponding alarm key is then operated, the office alarm will be silenced, the ACO lamp lighted, and the ALARM lamp extinguished. This operation does not inhibit the printout function.
- (b) **PRINT (Operated):** If the PRINT key is operated while in the automatic mode, normal

scanning will take place with a complete printout of all transducers on all cables. If the cable has an alarm condition, that cable will be printed twice and all others printed once.

- (c) **PRINT (Released):** Printout will occur for all transducers on all cables only at the 24- or 48-hour intervals depending on which option is provided or when an alarm occurs. If the system has a computer (ZN option), a printout can be requested at any time, either locally at the console or at a remote data terminal connected to the direct distance dialing (DDD) network. (See paragraphs 3.08 through 3.10.)

- (d) **PRINT OFF (1 through 8):** If one of the PRINT OFF buttons is operated, the printout which would occur due to alarms is inhibited. All other alarm features remain normal. This prevents recurrent printout of alarmed cables while repairs are being made.

- (e) **READ NEXT STATION:** When this key is operated, the next transducer following the one just measured will be read and printed. The MANUAL READY lamp is extinguished during the read and print operation and relights when the operation is complete. When this lamp relights, no further action will be taken until this key or another key is reoperated.

- (f) **READ NEXT STATION CONTINUOUS:** Operation of this key will command the control circuit to read and print each transducer on the cable sequentially. When the end of the cable is reached, the same cable will be reread and re-

printed repeatedly. No other manual operations can be initiated until the key is reoperated. ♦ This operation can also be stopped by operating the STANDBY, CLEAR, AUTO, CABLE ADVANCE, or RESET TO STATION 1 key. ♦

(g) **READ AND HOLD NEXT STATION, REREAD, and REREAD CONTINUOUS:** The operation of the READ AND HOLD NEXT STATION key initiates the order for the next transducer to be read and printed and held so that additional readings can be made on this station if necessary. The MANUAL READY lamp is extinguished throughout the read and print operation. If it is necessary to repeat the read and print operation on the same transducer, operate the REREAD key after the MANUAL READY lamp has relighted. The MANUAL READY lamp will again be extinguished during this read and print operation. If it is necessary to read the same transducer continuously, operate the REREAD CONTINUOUS key after the MANUAL READY lamp is relighted. The continuous reread operation is terminated by reoperating the REREAD CONTINUOUS key. Reoperation of the READ AND HOLD NEXT STATION key causes the READ AND HOLD NEXT STATION lamp to extinguish and terminates the continuous reread operation if it is active. If the next transducer is to be read and held, then the READ AND HOLD NEXT STATION key must be operated again.

(h) **RESET TO STATION 1:** The operation of this key will restore the central control circuit to transducer station 1 of the cable being measured.

(i) **CABLE ADVANCE:** If the CABLE ADVANCE key is operated, the central control will advance to the next cable and wait for further instructions. Any subsequent key operation other than a reoperation of the CABLE ADVANCE key will cause the new cable to be reset to transducer station 1 prior to executing the designated operation. If the CABLE ADVANCE key has been operated again, the central control would have advanced to the next cable without resetting the previous cable. The cable selected will be indicated by the cable number lamps.

(j) **STANDBY and CLEAR:** An operator may stop all automatic and manual operations and place the central control in a standby condition by

operating the STANDBY key. This operation causes the STANDBY lamp to flash at a 1-second rate and extinguishes all others except the cable number, print off, alarm, and alarm cutoff lamps. If the automatic or manual modes are reinitiated, readings will begin with the cable and transducer connected when the STANDBY key is operated. The central control may also be placed on standby by operating the CLEAR key. This operation not only places the equipment on standby, but also resets the logic circuitry to its normal starting condition and prepares the central control to start measuring transducer station 1 of cable 1. The clear feature is useful to clear lockup conditions that may occur during power turn on or after a plug-in printed board has been replaced.

3. TYPICAL OPERATION

3.01 Assume the system is operating in the automatic mode, pressure measurements are to be started on cable 1 and a printout is to occur on all transducer stations (illustrated in Fig. 12).

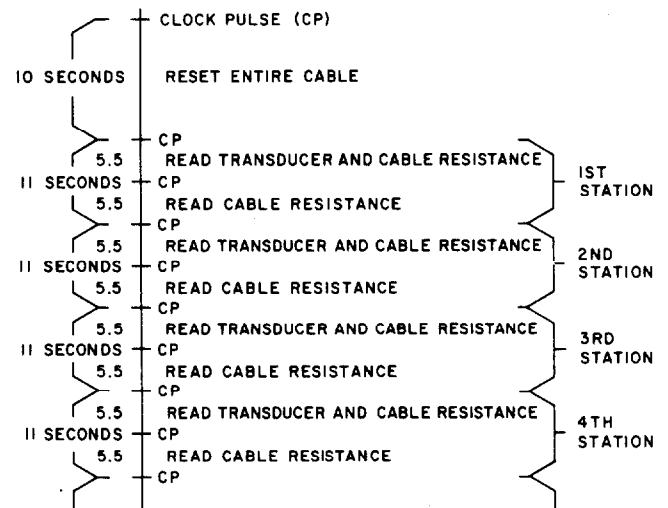

Fig. 12—Cable Pressure Measurement Time Sequence

3.02 The first clock pulse will activate the cable control circuit as follows:

- (1) The electronic cable counter and the printer cable counter will normally advance to the next cable; however, in this example the cable control circuit will reset and address cable 1.



(2) The current control circuit will apply a current to cable 1 for 10 seconds, resetting all transducers to the required initial state (the readout control circuit will be inhibited from measuring the cable for this 10-second period).

(3) The electronic station counter, printer station counter and alarm program counter will be reset. Cable 1 is now selected and the central control circuit is in the required state.

**3.03** After the end of the 10-second reset period, the next clock pulse activates the readout control circuit and initiates the following functions:

(1) The alarm pressure counter and printer pressure counter are reset to receive pressure information from the first transducer.

(2) The load number lead is activated.

(3) The current control circuit stops the cable reset current and applies a 1-milliampere measuring current to the cable.

(4) The timer in the readout control circuit is triggered which prevents any further action for a period of 3 seconds. This allows time for the voltage on the filters in the measuring path to reach a steady state after the application of the 1-milliampere measuring current.

**3.04** At the end of the 3-second period, the readout control circuit generates a sample pulse which activates the digital volt-ohmmeter (DVOM) and the input voltage is read. This voltage corresponds to the transducer resistance plus the cable loop resistance. When the DVOM has completed the measurement and the voltage reading is stored in a digital form, a read pulse is generated. This pulse plus the activated load number lead initiates the following action:

(1) The DVOM transfers the stored voltage reading to the printer pressure counter and alarm pressure counter.

(2) The current control circuit removes the 1-milliampere measuring current from the cable and applies a command current to operate a relay in the transducer placing a short across the transducer resistance. The DVOM readout then generates an end of voltmeter readout pulse.

**3.05** The next clock pulse, which occurs 5.5 seconds after the first, starts the second phase of the pressure measurement. Upon receipt of this pulse, the readout control circuit initiates the following:

(1) The electronic station counter and printer station counter advance one.

(2) The load number lead is deactivated and the local complement lead is activated.

(3) The current control circuit removes the command current from the cable and applies the 1-milliampere measuring current.

(4) The timer in the readout control circuit is triggered which prevents further action for 3 seconds.

**3.06** At the end of the 3-second period, a sample pulse is generated which causes the DVOM to read the voltage at its input. This voltage corresponds to the cable loop resistance only. When the DVOM has completed its measurement, a read pulse is generated. This pulse plus the active load complement lead causes the DVOM readout to add the nine's complement of the DVOM reading to the contents of the printer pressure counter and the alarm pressure counter. This is equivalent to subtracting the second DVOM reading from the first. The printer pressure counter and the alarm pressure counter now contain numbers which represent the gas pressure at transducer station 1. The read pulse also stops the 1-milliampere measuring current. When these actions are complete, the DVOM readout generates a second end of voltmeter readout pulse.

**3.07** The end of voltmeter readout pulse activates the print control circuit to issue a print command. The printer will then print and display the cable number, the transducer number, and the transducer gas pressure. After the generation of the second read pulse in the station measurement, a timer in the current control resets and applies a command current to the cable. This current operates a relay in transducer station 1 releasing the transducer and connects the next transducer to the measuring circuit. The next clock pulse will then repeat the sequence on transducer station 2.

**3.08** ♦Systems equipped with SD-5G142-01, ZN option, have a microcomputer and a thermal printer. The most recent set of pressure measure-

ments are stored in memory, and a memory dump can be initiated by operating the INTERRUPT switch on the central control panel (Fig. 7). The most recent pressure readings for all stations in the system are printed at the rate of 2.5 stations per second (Fig. 13). A "Most Recent" message precedes the listing and shows which cable and transducer the system was monitoring when the printout started.

**3.09** The memory dump also includes a scan number following the list of measurements on each cable. The scan number is incremented each time the system reads transducer 1 on cable 1 and can be used to determine the order or relative time of the measurements.

**3.10** In addition, the microcomputer allows remote access to pressure data over the DDD network. A 300-baud data set with automatic answer is required and must be installed within 50 cable feet of the central control unit. The remote data terminal must operate at 300-baud full duplex and transmit and receive data in the American standard code for information interchange (ASCII) upper case and numbers format. The operator at the remote terminal can request information in one of three available formats:

- All transducers on all cables
- All transducers on one particular cable
- Any group of ten consecutive transducers on the same cable.

**3.11** When operating in one of the manual modes or when the PRINT key is operated, a real-time printout is produced with the ZN option as previously described for the impact printer (ZO option). However, instead of data being pulsed into the printer directly, the information for pressure, cable number, station number, and control signals are input to the computer. The computer processes and stores the information and, if printing is enabled, sends data to be printed and control signals to the printer.

**3.12** The thermal printer receives ASCII characters sequentially from the computer until a line of data is stored in its random access memory (RAM). It then prints one line under control of the computer. ALARM and INVALID messages are also printed. The INVALID message is printed when the

2 003-----	23.6
2 002-----	23.6
2 001-----	24.8
SCAN 2002-CABLE NO. 1	
1 074-----	25.9
1 073-----	24.3
1 072-----	23.6
1 071-----	23.0
1 070-----	22.4
1 069-----	21.8
1 068-----	21.8
1 067-----	21.9
1 066-----	22.0
1 028-----	23.5
1 027-----	24.3
1 026-----	24.7
1 025-----	23.9
1 024-----	23.3
1 023-----	22.8
1 022-----	22.3
1 021-----	21.8
1 020-----	21.4
1 019-----	21.1
1 018-----	21.0
1 017-----	21.0
1 016-----	21.1
1 015-----	21.2
1 014-----	21.2
1 013-----	21.1
1 012-----	21.0
1 011-----	21.0
1 010-----	21.0
1 009-----	21.0
1 008-----	21.2
1 007-----	21.2
1 006-----	21.3
1 005-----	21.6
1 004-----	22.3
1 003-----	22.9
1 002-----	23.4
1 001-----	24.2
1 006 MOST RECENT	

◆Fig. 13—Sample Printout◆

pressure is out of range, ie, below 10.0 or above 26.5 pounds per square inch absolute (PSIA). INVALID indicates equipment failure while ALARM indicates low pressure.♦

#### 4. ALARMS

**4.01** The electronic station counter is connected to a translator which transforms its output into convenient decimal form for use in programming the alarm system. The alarm system is capable of setting different alarm levels for up to eight sections within any cable. The transducers at which the alarm level is to change, as well as the alarm levels themselves, are programmed into a program patch board by means of cross-connections. The alarm level is set only on the first two digits of the pressure. The tens digit can only be 1 or 2 but the units digit range is 0 through 9. The third and fourth digits of any alarm level are assumed to be zero. Each cable is provided with its own program board so the program for each cable may be set up independently. Switching from one board to another is done through cable select relays.

**4.02** The alarm program counter may assume one of eight states, one state for each alarm section of the cable. At the beginning of the cable the alarm program counter is reset. This state selects the first of the eight alarm levels which have been programmed on the program patch board. This alarm level is compared in the comparator with the actual pressure reading read into the alarm pressure counter. If the pressure reading is equal to or greater than the alarm level, then no action is taken. If the pressure reading is less than the alarm level, it is recog-

nized by the alarm control circuits and an alarm is sounded.

**4.03** This action continues until the electronic station counter arrives at a transducer at which the alarm level must change. The station number of this transducer is programmed on the program patch board. Then the alarm program counter is advanced to a new state which, in turn, selects the second of the eight alarm levels. This continues until the cable has been fully read.

**4.04** The program board for a given cable must be cross-connected for the total number of transducers on the cable. When the last transducer on a cable is reached, the output of the station counter is connected through the program board to give an end-of-cable signal to the cable control circuits. If there is no alarm on the cable, the cable control circuits will advance the cable counter and thereby start measurements on the next cable. If an alarm is present, this information is stored by the alarm control circuit which prevents the cable control circuit from advancing the cable counter. The cable control circuit will then reset and reread the same cable. This provides a double printout of the alarmed cable if the PRINT key has been operated. After this second reading, the central control unit will advance to the next cable and normal operation will resume.

**4.05** A remote alarm and a remote alarm reset are provided at a remote location on an optional basis. The central control unit alarm can be reset from the remote location when this feature is utilized.