

SPEED TEST CIRCUIT
FOR TOUCH-TONE® AUTOMATIC DIALERS
SD-1C402-01
TESTS AND ADJUSTMENTS

1. GENERAL

1.01 This section describes a method for testing and adjusting the speed test circuit for TOUCH-TONE® automatic dialers (SD-1C402-01).

1.02 This section is reissued for the following reasons:

- (a) To correct cable assembly designation.
- (b) To rearrange the steps of the Detector Test.
- (c) To change Fig. 1 and 2 to change test point, and show potentiometers as they appear on the equipment.

1.03 The tests and adjustments covered are:

PAGE

A. *Timer Test and Adjustment:* This test checks that the timer circuit accurately verifies that the time burst, break and digit period of TOUCH-TONE® digits dialed by automatic dialers are of adequate duration.

3

B. *Detector Test:* This test checks that the detector circuit accurately converts the received ac TOUCH-TONE® digits to dc pulses of equal duration for measurement by the timing circuit and that a nominal 33 ms pulse is produced as an indication to the connecting circuit that a valid digit has been received.

4

1.04 Prior to making any tests or adjustments, the associated station ringer test circuit, TOUCH-TONE® frequency test circuit, or other connecting circuit which accesses the speed test circuit must be made busy. Make busy procedures for the type of central office involved, shall be followed.

1.05 If the speed test circuit is located in a No. 1 ESS office, the POWER OFF key associated with the station ringer test circuit shall be operated.

1.06 *Lettered Steps:* A letter a, b, c, etc, added to a step number in Part 3 or 4 of this section indicates an action which may or may not be required depending on local conditions. The condition under which a lettered step or a series of lettered steps should be made is given in the ACTION column, and all steps governed by the same condition are designated by the same letter within a test. Where a condition does not apply, all steps designated by that letter should be omitted.

2. APPARATUS

2.01 The apparatus required for each test is shown in Table A. The details of each item are covered in the paragraph indicated by the number in parentheses. Calibration and operating procedures for test sets are found in the section listed with the test set. The testing equipment should be known to be correctly calibrated.

2.02 J94021A (21A) Transmission measuring set (TMS). (Section 103-221-100).

2.03 Hewlett-Packard 5233L or 5325B electronic counter or equivalent.

2.04 Hewlett-Packard 11001A cable assembly.

2.05 KS-14510 L2 test lead, equipped with test prod at one end and a connector at the other end.

2.06 KS-14510 L3 test lead, equipped with an alligator clip at one end and a connector at the other end.

2.07 Testing cord, W1BB cord, 2 feet long.

TABLE A

APPARATUS	TESTS	
	A	B
TMS (2.02)		1
Electronic Counter (2.03)	1	1
Cable Assembly (2.04)	1	2
Test Lead (2.05)	1	2
Test Lead (2.06)	1	2
Testing Cord (2.07)	1	2
Testing Cord (2.08)	1	1
Testing Cord (2.09)		1
Patching Cord (2.10)		1
KS-6278 Clip (2.11)		1
Screwdriver (2.12)	1	

2.08 Testing cord, W1BC cord, 10 inches long.

2.09 Testing cord, W2BG cord, equipped with one 241A plug, one KS-19531 L1 plug (red), and one KS-19531 L2 plug (black) (2W51A cord).

2.10 Patching cord, P1Y cord, 1 foot long.

2.11 KS-6278 connecting clip.

2.12 Screwdriver Stanley Tools 1017 for adjusting potentiometers.

3. PREPARATION

STEP

ACTION

VERIFICATION

Tests A and B

Note: The connecting circuit having access to the speed test circuit shall be made busy (see 1.03).

- 1a If testing in a No. 1 ESS office—
At the station ringer test circuit—
Operate POWER OFF switch.
- 2 At speed test circuit—
Using W1BC cord, connect the timer circuit pack Y jack to the TS jack (Fig. 1.)
- 3 Using W1BB cord, connect the detector circuit pack R jack to frame ground.
- 4 At electronic counter—
Connect power cord to ac power supply and operate power switch to ON.
- 5 Using HP 11001A cable assembly, connect to A jack of electronic counter.

STEP	ACTION	VERIFICATION
6	Using KS-14510 L3 test lead, connect the ground side (shield conductor) of HP 11001A cable assembly to frame ground.	

4. METHOD

STEP	ACTION	VERIFICATION
A. Timer Test and Adjustment (Fig. 1)		
7	At speed test circuit— Using KS-14510 L2 test lead, connect center conductor of HP 11001A cable assembly to timer circuit pack TS jack.	
8	At electronic counter— Set FUNCTION for time interval A to B.	
9	Set A and B attenuators to X10.	
10	Set selectors to AC volts.	
11	Set channel input switch to COM.	
12	Set time interval (SLOPE) for +(plus) to -(minus) time.	
13	Set TIME BASE for 1 μ s.	Electronic counter indicates 49500 μ s \pm 100 μ s. (49.50 ms \pm 0.1 ms)
14b	If verification in Step 13 is not obtained— At speed test circuit, timer circuit pack— Adjust R16 potentiometer to obtain an indication on electronic counter of 49.50 ms \pm 0.02 ms.	
15	At electronic counter— Set time interval (SLOPE) for -(minus) to +(plus) time.	Electronic counter indicates 45500 μ s \pm 100 μ s. (45.50 ms \pm 0.1 ms)
16	If verification in Step 15 is not obtained— At speed test circuit, timer circuit pack— Adjust R5 potentiometer to obtain an indication on electronic counter of 45.50 ms \pm 0.02 ms.	
17	At electronic counter— Set time interval (SLOPE) for -(minus) to -(minus) time.	Electronic counter indicates 95000 μ s \pm 100 μ s. (95.00 ms \pm 0.1 ms)
18	If verification in Step 17 is not obtained— At speed test circuit, timer circuit pack— Adjust R5 potentiometer to obtain an indication on electronic counter of 95.00 ms \pm 0.02 ms.	

SECTION 201-819-501

STEP	ACTION	VERIFICATION
19	Repeat Steps 12 through 18d to assure proper time intervals.	
20	At speed test circuit— Disconnect KS-14510 L2 test lead from detector circuit pack TS jack and connect to timer circuit pack TBA jack.	
21	At electronic counter— Set time interval (SLOPE) for –(minus) to +(plus) time.	Electronic counter indicates $\blacklozenge 10500 \mu\text{s} \pm 50 \mu\text{s} \blacklozenge$ (10.50 ms ± 0.05 ms)
22	At speed test circuit— Disconnect KS-14510 L2 test lead from timer circuit pack TBA jack.	

B. Detector Test (Fig. 2)

7	At speed test circuit— Using KS-14510 L2 test lead, connect center conductor of HP $\blacklozenge 11001A \blacklozenge$ cable assembly to timer circuit pack OUT jack.	
8	At electronic counter— Set FUNCTION for time interval A to B.	
9	Set time interval (SLOPE) for –(minus) to +(plus) time.	Electronic counter indicates $\blacklozenge 33000 \mu\text{s} \pm 2000 \mu\text{s} \blacklozenge$ (33.0 ms ± 2.0 ms)
10	Note electronic counter indication in Step 9.	
11	At 21A TMS— Adjust controls on 21A TMS to deliver 2000 Hz at 0 dBm.	
12	Using 2W51A cord and P1Y cord, connect 21A TMS OSC OUT jack (BLACK LEAD) to speed test circuit timer circuit pack SCT jack, and (RED LEAD) to P1Y cord and P1Y cord to frame ground.	
13	At speed test circuit— Using W1BB cord, connect the detector circuit pack T jack to the timer circuit pack SCT jack.	
14	At speed test circuit— Disconnect KS-14510 L2 test lead from the timer circuit pack OUT jack and connect to the detector circuit pack RP jack.	

STEP	ACTION	VERIFICATION
15	At electronic counter— Set time interval (SLOPE) for +(plus) to -(minus) time.	Electronic counter indication shall be 0 to $\pm 3500 \mu\text{s}$ longer than the indication noted in Step 10.
16	Using HP $\#11001A$ cable assembly, connect to B jack of electronic counter.	
17	Using KS-14510 L3 test lead, connect the ground side (shield conductor) of HP $\#11001A$ cable assembly to frame ground.	
18	At electronic counter— Set channel input switch to SEP.	
19	At electronic counter— Set time interval (SLOPE) for -(minus) to -(minus) time.	
20	At speed test circuit— Using KS-14510 L2 test lead, connect center conductor of HP $\#11001A$ cable assembly to detector circuit pack DRP jack.	Electronic counter indicates $\pm 3000 \mu\text{s} \pm 500 \mu\text{s}$. (3.0 ms \pm 0.5 ms)
21	Note electronic counter indication in Step 20.	
22	Set time interval (SLOPE) for +(plus) to +(plus) time.	Electronic counter indication shall be within $100 \mu\text{s}$ (0.1 ms) of indication noted in Step 21.
23	Disconnect all testing cords and apparatus.	
24g	If no further tests are to be performed— Restore all connecting circuits to normal.	

SPEED TEST CIRCUIT FOR TOUCH-TONE[®]
 AUTOMATIC DIALERS SD-1C402-01.

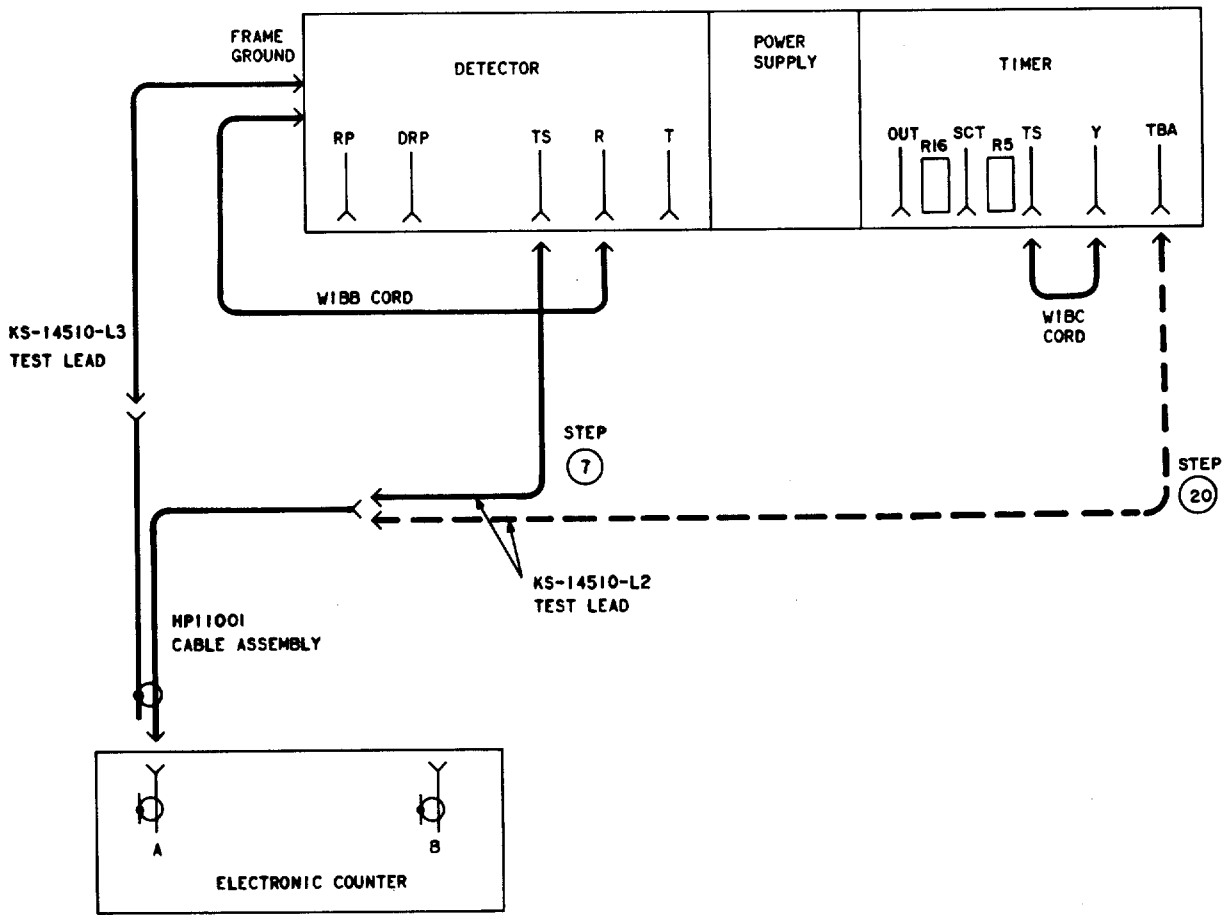

Fig. 1—Test A Connections

SPEED TEST CIRCUIT FOR TOUCH-TONE®
AUTOMATIC DIALERS SD-1C402-01.

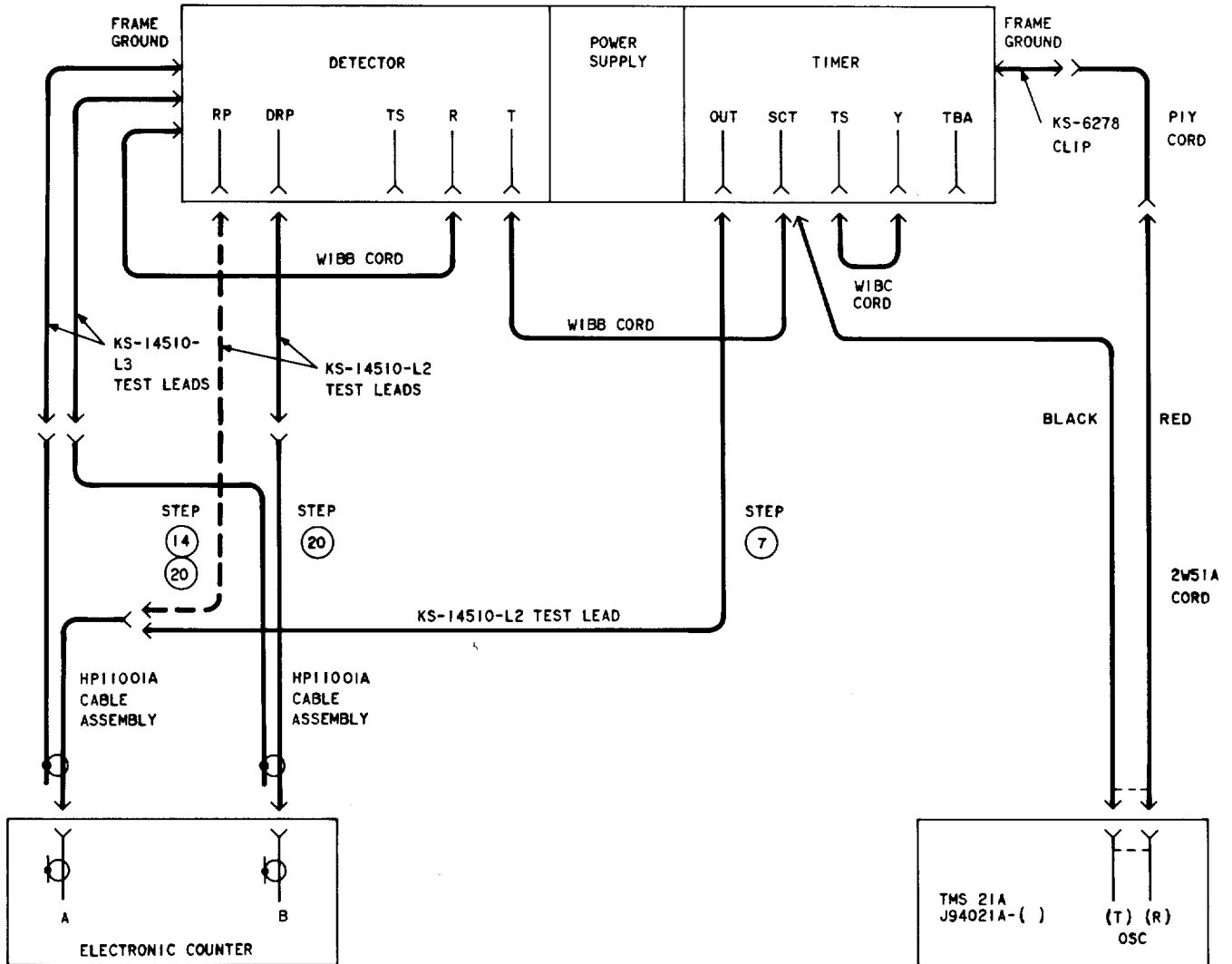

Fig. 2—Test B Connections