

BELL SYSTEM PRACTICES
Plant Series

This Practice No. _____
List # PAC 1 Date 9-4-63
B.S.P.M. # _____ O. & E. List # _____

SECTION 220-409-501PT
APPENDIX 2
Issue A, 12-15-56
Pacific Tel.

RETURN LOSS TESTS
ON TOLL CONNECTING TRUNKS
CROSSBAR TANDEM SYSTEMS.

1. GENERAL

1.01 This appendix describes a method of making return loss tests on toll connecting trunks in crossbar tandem offices.

1.02 The tests covered are:

(A) Return Loss Tests - Incoming Toll Connecting Trunks.

(B) Return Loss Tests - Outgoing Toll Connecting Trunks.

1.03 An assistant is required at the distant office for testing incoming trunks and outgoing trunks to operators.

1.04 A drawing of the return loss test equipment arrangement at the outgoing trunk test jack bay is shown in Figure 1.

2. APPARATUS

2.01 The apparatus required for each test is shown in the following list. The details for each item are covered in the indicated paragraphs.

Apparatus	Paragraph	No. Required for Tests	
		(A)	(B)
Transmission Measuring Set	2.02	1	1
Test Circuit	2.03	1	1
Patching Cord	2.04	2	2
Patching Cord	2.05	1	1
Patching Cord	2.06	-	1
Special Plug	2.07	-	1

2.02 21A Transmission Measuring Set J94021A, (SD 95115-01) or equivalent.

2.03 Test Circuit J98501 (SD-95476-01) Manual Outgoing Trunk Test Frame equipped with Return Loss Test Circuit per DW-25006-11.

2.04 P3N cord, 6 feet long, (3P17B) Modified locally by replacing 310 plug with a 309 plug.

2.05 P3D cord, 6 feet long, equipped with two No. 309 plugs (3P3A).

2.06 P3F cord, 8 feet long, equipped with one No. 309 plug and one No. 310 plug (3P12H).

2.07 309 open plug.

3. PREPARATION

All Tests

3.01 Determine the return loss requirement of the trunk circuits to be tested from the trunk records, trunk order, or circuit order.

3.02 Calibrate the 21A transmission measuring set as described in the A702 Subdivision entitled "21A Transmission Measuring Set - J94021A."

3.03 Adjust the oscillator section of the 21A transmission measuring set as follows:

(a) Verify that the plug is removed from the 2W TK jack at the outgoing trunk jack bay.

(b) Using a modified P3N cord patch the OSC OUT 600-ohm jack of the 21A transmission measuring set to the 4W IN jack at the outgoing trunk jack bay.

(c) Using a modified P3N cord, patch the DET IN 600-ohm jack of the 21A transmission measuring set to the 4W OUT jack at the outgoing trunk jack bay.

(d) Adjust the oscillator to obtain "O" reading on the DB meter. The oscillator output should be from +6.5 to 7.0 dbm.

Test B

3.04 For the list of keys and interpretation of lamps when using the manual outgoing trunk test frame, refer to the section on "Outgoing Trunks Using Manual Outgoing Trunk Test Frame."

SECTION 220-409-501PT
APPENDIX 2

4. METHOD

(A) Return Loss Tests - Incoming Toll Connecting Trunks.

- 4.01 Make this test from the manual outgoing trunk test frame.
- 4.02 Request the assistant at the originating office to call on the trunk under test using code 974 to reach the manual outgoing trunk test frame.
- 4.03 Operate the TALK key when the TL lamp lights at the test frame.
- 4.04 Request the assistant at the originating office to terminate the trunk as follows:

Dial Offices - Request connection to a 900 ohms termination.

Switchboards - Request connection to the SING test termination with TALK key normal.

- 4.05 Verify that the plug is removed from the NBO jack.
- 4.06 Insert one end of a P3D cord into the 2W TK jack. Insert the other end of the same cord into the INC TL jack.

Trunk Order Tests

4.07 Sweep the oscillator of the 21A transmission measuring set from 300 to 3000 cycles and record the following measurements on Form P2421SC "Trunk Order Tests:"

- (a) The minimum return loss between 300 and 750 cycles.
 - (b) The minimum return loss between 750 and 2000 cycles.
 - (c) The return loss at 2000 cycles and each "peak" and "valley" of return loss and the frequency at which they occur up to and including the return loss at 3000 cycles.
 - (d) Determine that the minimum return loss between 2000 and 3000 cycles equals or exceeds the minimum specified.
- 4.08 Remove the P3D cord from the INC TL jack and restore the TALK key. When no other trunks are to be tested, remove all cords.

Routine Tests

4.09 Sweep the oscillator of the 21A transmission measuring set from 2000 to 3000 cycles; verify that the return loss does not fall below the minimum return loss specified in the trunk records for the trunk group under test.

4.10 Request the assistant at the originating office to restore the trunk to service. Remove the P3D cord from the INC TL jack and restore the TALK key. When no other trunks are to be tested, remove all cords.

(B) Return Loss Tests - Outgoing Toll Connecting Trunks.

4.11 Insert a make busy plug into the MB jack of the trunk to be tested at the outgoing trunk test jack bay.

4.12 Using a P3D cord, connect from the PLS jack to the T1 or T2 jack.

4.13 Using a P3F cord, connect the 2W TK jack to the T jack of the trunk to be tested.

4.14 Insert 309 open plug in NBO jack.

4.15 Originate a call to a 900 ohms termination in dial offices or a SING test termination at switchboards as described in the section on "Outgoing Trunks Using Manual Outgoing Trunk Test Frame."

Trunk Order Tests

4.16 Sweep the oscillator of the 21A transmission measuring set from 300 to 3000 cycles and record the following measurements on Form P2421SC, Trunk Order Tests.

- (a) The minimum return loss between 300 and 750 cycles.
- (b) The minimum return loss between 750 and 2000 cycles.
- (c) The return loss at 2000 cycles and each "peak" and "valley" of return loss and the frequency at which they occur up to and including the return loss at 3000 cycles.
- (d) Determine that the minimum return loss between 2000 and 3000 cycles equals or exceeds the minimum specified.

4.17 On trunks to operators, request the attendant at the terminating office to take down the connection to the SING test termination. Remove the plug from the T jack. Remove all cords when no other trunks are to be tested.

Routine Tests

4.18 Sweep the oscillator of the 21A transmission measuring set from 2000 to 3000 cycles; verify that the return loss does not fall below the minimum return loss specified in the trunk records for the trunk group under test.

4.19 On trunks to operators, request the attendant at the terminating office to take down the connection to the SING test termination. Remove the plug from the T jack and remove the make busy plug from the MB jack. Remove all the cords when no other trunks are to be tested.

5. REPORTS

5.01 The required record of these tests shall be recorded on form P2421SC.

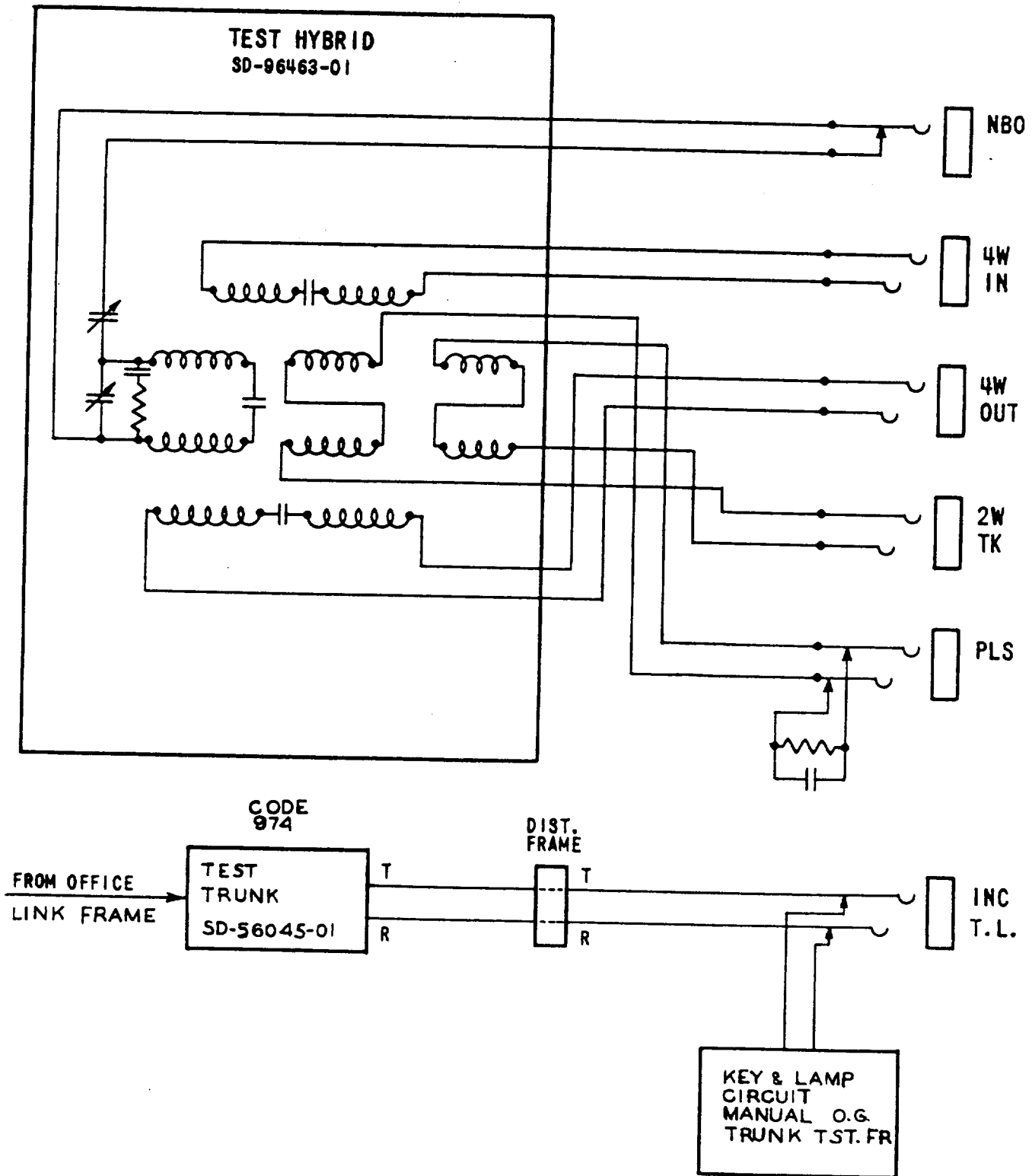

Figure 1 - Return Loss Test Equipment Arrangement
 at the Outgoing Trunk Test Jack Bay