

**CALL DATA ACCUMULATOR
NETWORK DESIGN
LOCAL STEP-BY-STEP**

CONTENTS	PAGE	CONTENTS	PAGE
1. GENERAL	3	Line Finders	5
2. EQUIPMENT ARRANGEMENTS	3	Class Marks	5
GENERAL	3	Controlled Outpulsing, Common Control TOUCH-TONE, and Noncommon Control TOUCH-TONE	6
A. Principle Call Data Accumulator Equipment	3	B. Call Progress	6
Multiplexer	4	Multiplexer	6
Scan Control	4	Scan Control	6
Line Finder Sleeve Relays	4	Identification Relay Selector	6
Identification Relay Selector	4	Line Identification Control (For ANI-C and D)	6
Line Identification Control (ANI-C and ANI-D)	4	Transmitting and Recording	6
Miscellaneous Circuit	5	Data Links	7
B. Associated Equipment	5	4. DETERMINATION OF REQUIREMENTS	7
Automatic Number Identification (ANI)	5	GENERAL	7
Controlled Outpulsing, Common Control TOUCH-TONE® and Noncommon Control TOUCH-TONE	5	EQUIPMENT PROVISION	7
3. OPERATION AND USE	5	FIGURES	
GENERAL	5	CONTENTS	PAGE
A. Principles of Operation	5	1. Call Data Accumulator Typical Configuration	9
Single Message Unit	5	2. Call Data Accumulator with Automatic Number Identification Type B	10
Multimessage Unit	5		

NOTICE

Not for use or disclosure outside the
Bell System except under written agreement

CONTENTS	PAGE	CONTENTS	PAGE
3. Call Data Accumulator with Automatic Number Identification Types C and D	. 11	4. Items Specified in Network Design Order	12

CALL DATA ACCUMULATOR

NETWORK DESIGN

LOCAL STEP-BY-STEP

1. GENERAL

1.01 The implementation of tariffs that link the charges for basic telephone service to the volume of local usage (Measured Service) requires a detailed record of local calls. Currently, where measured rate class of service is offered in Step-by-Step offices, the number of calls is accumulated on mechanical message registers which must be manually transcribed. Message registers carry no information on individual calls. To implement Measured Service, a centralized Automatic Message Accounting Recording Center (AMARC), making use of duplicated minicomputers, has been developed to collect and record call details on local calls from individual noncoin subscriber lines. The device which gathers the local billing data at a switching office and transmits it to an AMARC, is known as a terminal. The Call Data Accumulator (CDA) is the terminal system developed for No. 1, 350A, 355A, 360A and 35E97 Step-by-Step switching offices to interface with an AMARC. This practice covers the description and operation of CDA and its relationship to an AMARC.

1.02 Whenever this section is reissued, the reason(s) for reissue will be listed in this paragraph. This section was previously identified as Traffic Facilities Practices, Division D, Section 4-m.

1.03 References in this section to methods, planning, data requirements, service levels, and equipment quantities are based on American Telephone and Telegraph Company recommendations.

1.04 The title for each figure includes a number(s) in parentheses which identifies the paragraph(s) in which the figure is referenced.

2. EQUIPMENT ARRANGEMENT

GENERAL

2.01 Call Data Accumulator (CDA) equipment communicates with the AMARC via dedicated data link facilities, with automatic dialed back-up via the message network.

2.02 The CDA is added to Step-by-Step offices to provide a per-call record for every answered noncoin local call placed from an *individual line*. Party line customers cannot be properly identified, therefore Measured Service is not applicable to party lines. The call record consists of:

- Calling number
- Time of day of answer
- Time of day of disconnect, or duration
- Message billing index (optional)
- Called number (optional)

The CDA is designed with integrated circuits for high reliability, small size, and economy. Step-by-Step offices of any size can be equipped with CDA. It is modularized for efficient application to Community Dial offices (CDOs) and large urban offices alike, and is compatible with the standard Step-by-Step central office environment. Step-by-Step offices must be equipped with Automatic Number Identification (ANI) systems of any standard type for CDA operation. ANI B, C, and D systems must be modified to interface with CDA. CDA is compatible with Step-by-Step offices equipped with standard noncommon control TOUCH-TONE converters and with standard common control converters when they are not used with common control outpulsing. It is not compatible with standard common control outpulsing unless dialed digit outpulsing is used with immediate start signaling. If MF outpulsing with wink start signaling is used, only the single message unit (SMU) option in the CDA is compatible. The CDA may be applied to Stromberg-Carlson offices and should not encounter any functional problems when installed in an office containing converters which are ITT Tel-Touch, ATC, MITEL CM 125 or Tel-Tone M-164.

A. Principle CDA Equipment

2.03 CDA equipment is arranged for miscellaneous relay rack mounting in the local Step-by-Step

office and consists primarily of printed circuit boards using both discrete and integrated circuit technology. CDA is made up of the following equipment:

- Multiplexer
- Scan Control
- Line Finder Sleeve Relays
- Identification Relay Selector
- Line Identification Control (ANI-C and ANI-D)
- Miscellaneous Circuits for Fuses and Alarms.

CDA equipment, arranged to accommodate up to 496 line finders will fit on 50 inches of miscellaneous relay rack space, with the exception of the line finder relays which mount in the rear of their associated line finder switches. CDA equipment necessary to serve 992 line finders will fit on one 11' 6" frame. The recommended arrangement is shown in Fig. 1. The major location limitation is determined by the cable length between the multiplexer and its associated first selectors which is limited to 250 feet.

Multiplexer

2.04 Multiplexer equipment scans the tip, ring and sleeve leads of the first selectors. Each multiplexer serves a maximum of 248 first selectors. It is modularized with the mounting unit occupying 12 inches of relay rack space. A multiplexer plug-in circuit board is arranged to serve 16 scan points or "address points" (all address points are referenced in Octal, Base 8). There is no requirement for the selectors served by one circuit board to be contained in the same line finder group.

Scan Control

2.05 Scan Control equipment provides centralized control and sequence analysis for a maximum of two multiplexers. Each scan control serves a maximum of 496 line finder—first selector combinations. It mounts on 12 inches of relay rack space. The scan control contains a 202T data set for a dedicated private line and a 202S data set for a receive-only dial-up line. Each scan control in an entity is equipped with its own dedicated data link and input channel to the AMARC.

Line Finder Sleeve Relays

2.06 A new relay must be added to each line finder in every line finder group arranged for CDA to control the ANI signal (tone with ANI-B, pulse with ANI-C and ANI-D) on the sleeve lead for calling number identification by ANI. The relay is mounted on a printed circuit board on the wiring side of the line finder shelves and can be connected to the line finder without removing the switch from its jack.

Identification Relay Selector

2.07 Identification Relay Selector equipment provides the interface between the scan control and the line finder relays. It is modularized and contains 16 plug-in circuit boards, each of which is equipped with 32 relay drivers. The identification relay selector can individually address each relay driver which in turn is used to operate the relays on the line finder to permit the calling number identification process. One relay driver is provided per line finder relay. Sixteen boards provide 496 relay drivers for line finder relay control (plus 16 for test). The Identification Relay Selector mounting unit requires six inches of relay rack space and is mounted adjacent to one or two multiplexers.

Line Identification Control (ANI-C and ANI-D)

2.08 Line Identification Control equipment is required for offices equipped with ANI-C or ANI-D. This is modular; plug-in circuit boards are used to accommodate from one to four scan controls for ANI-C and D. If CDA is to work with ANI-B, the line identification control unit is not required, because the function is built into the new identifiers modified for CDA. The Line Identification Control coordinates requests for line identification from the scan control(s) and institutes the start of identification. This equipment also picks up data from the ANI identifier, reformats it and passes it on to the requesting scan control. The equipment occupies six inches of relay rack space and serves a maximum of four scan controls. It is normally mounted along with the scan control(s) but may be mounted on any miscellaneous relay rack frame.

Miscellaneous Circuits

2.09 Miscellaneous circuit equipment provides fuse alarms, power supply alarms, alarm lamps and jacks to various parts of the central office. It requires 2 inches of relay rack space for mounting.

B. Associated Equipment

Automatic Number Identification (ANI)

2.10 ANI-B requires the replacement of the present identifier equipment by identifier equipment with high speed equipment for use with CDA. The new unit includes provision for the required class marks and for the coordination of number identification requests. When ANI-B is used, the functions of the line identification control are performed by the new ANI-B identifier, which is not considered part of the CDA. The new ANI-B identifier can accommodate up to 16 scan control units. (See Fig. 2).

2.11 ANI-C and ANI-D equipment is modified to provide class marks which identify flat or measured rate service when used with CDA. A line identification control is used to interface with ANI-C and ANI-D. This unit receives requests for up to four scan controls when used with ANI-C or ANI-D. It grants requests and in turn, prevents interference with toll requests and controls the ANI pulse generators for local calls. (See Fig. 3).

Controlled Outpulsing, Common Control TOUCH-TONE and Noncommon Control TOUCH-TONE

2.12 Step-by-Step offices with these types of equipment are acceptable for the provision of CDAs if MF outpulsing is not used.

3. OPERATION AND USE

GENERAL

3.01 Call Data Accumulator (CDA) provides a means of obtaining billing information for local calls on *individual* customer lines in a Step-by-Step switching system. This information is sent via a dedicated data link to the Automatic Message Accounting Recording Center (AMARC) for further processing.

A. Principles of Operation

Single Message Unit

3.02 The information which is transmitted to the No. 1 AMARC, using the option known as single message unit (SMU), consists of the calling number, the time of day answer, the address of the first selector being used (scan point address), and the time of day disconnect. This information is transmitted in two parts. The first, or answer message, consists of the calling number, the time of day answer and the scan point address. The second message, transmitted when disconnect occurs, consists of the time of day disconnect and the scan point address. The two messages are matched by the AMARC processor and recorded on magnetic tape as one complete message.

Multimessage Unit

3.03 As an option, the multimessage unit (MMU) feature may be provided initially or added to installed systems. Where MMU is used, the *called* number is transmitted to the AMARC in addition to the details of SMU. The MMU feature may be provided even where SMU tariffs are used, so that the called number is available, if desired, for detailed billing, complaint service observing, and detection of premature answer supervision at the AMARC. If the SMU option is chosen, the called number is not sent forward to the AMARC as each call is rated the same. If one Step-by-Step office served by AMARC is equipped for MMU type recording, all the other Step offices served by the same AMARC must be similarly equipped.

Line Finders

3.04 All line finders in a particular line finder group must be assigned to the CDA. Flat rate and measured rate lines may be intermixed in the same line group. Prepay coin lines can not be accommodated. Any post-pay coin lines assigned to the same line finder groups as noncoin are treated as flat rate.

Class Marks

3.05 In addition to the original class mark capability of toll ANI, modified versions of ANI-B, C, and D operating with CDAs provide for two new class marks, one for measured rate customers and

one for flat rate customers. The class marks, which distinguish flat rate from measured rate customers, are used by the processor at the AMARC to determine which calls are chargeable and therefore must be recorded. Only individual subscribers may be assigned a class mark. Class marks in Step-by-Step offices are administered by strapping at the ANI number network frames. With ANI-B, as an option, measured and flat rate individual lines are distinguished at the number networks by strapping the sleeve of one of the two classes to a terminal on a class mark diode board. With ANI-C and D, a diode isolation circuit board in each number network unit provides the two new class marks for individual measured (IM) and individual flat (IF) busses.

Controlled Outpulsing, Common Control TOUCH-TONE and Noncommon Control TOUCH-TONE

3.06 Provision has been made for use of CDA equipment with common control Step-by-Step offices using dial pulse sending with either by-link or wink start operation. When the MMU option is used, prefixed or arbitrary digits are deleted by the scan control and the seven digits of the called number are transmitted to the AMARC. Noncommon control TOUCH-TONE equipment is fully compatible with the CDA equipment as long as multifrequency (MF) outpulsing is not used. If MF outpulsing is used, the MMU option cannot be provided.

B. Call Progress

Multiplexer

3.07 When a subscriber originates a call, a line finder and first selector are seized. The multiplexer detects this activity by monitoring the tip, ring and sleeve leads of the first selector via the input network which is the Step-by-Step interface in the multiplexer. The information which the multiplexer receives contains the dial pulse and supervisory signals from the customer's line as well as the address of the first selector being used.

Scan Control

3.08 The information that a call is in progress is forwarded to the scan control where it is stored until an answer condition is received. When an answer is detected by the multiplexer, it relays

this condition to the scan control. The scan control accepts the information from the multiplexer and requests that the calling number identification be made. The scan control coordinates the actions of all other units and exchanges data with these units and the AMARC. A failure in the scan control circuit would result in the loss of ability to perform these actions and therefore result in loss of call records. A message noting the failure would be printed out at the AMARC.

Identification Relay Selector

3.09 The calling number identification request is generated by the scan control to the ANI equipment. At this time the appropriate relay driver is selected to operate the identification relay in the line finder. The relay operation allows a pulse, in the case of ANI-C and D, or a tone in the case of ANI-B, to be introduced on the sleeve lead at the line finder. When the signal is applied to the sleeve lead of the line finder, the regular identification process, via the number networks and the detectors in the ANI system, takes place.

Line Identification Control (For ANI-C and D)

3.10 The information derived from the identification process in the ANI system, consisting of calling office code, thousands, hundreds, tens and units digits, plus status code (comprised of class mark and various trouble messages) is transmitted to the scan control by the line identification control that interfaces with the ANI-C and D systems in the CDA. The line identifying information for ANI-B is transmitted directly to the scan control from the ANI-B identifier. The line identification control is not used by the ANI-B system.

Transmitting and Recording

3.11 After the calling number is identified, an answer message is sent from the scan control to the AMARC over a dedicated data link. The answer message includes the calling subscriber's directory number, called number (if MMU is provided), a flat or measured rate class mark, the answer status code, and the scan point address of the first selector being used. Each first selector has a scan port address, (the location of its assignment to a circuit board of the multiplexer). The first selector is permanently related to its scan port address in the core memory of the AMARC and is used by the processor to associate call details.

3.12 When the calling line disconnects, the disconnect status is detected through the tip, ring and sleeve lead connections to the line finder-first selector by the multiplexer and relayed, together with the scan point address to the scan control. The scan control then sends the disconnect message consisting of the disconnect status code and the scan point address to the AMARC via the data link.

3.13 If the call was a completed call from an individual measured rate customer, the processor at the AMARC assembles the stored data for the call, analyzes it, and causes the recording of it on magnetic tape as one message. Although flat rate call details are transmitted to the AMARC, an option has been provided there so that they need not be processed and recorded on the magnetic tape if the call mark option has been provided at the CDA.

Data Links

3.14 The dedicated data links must fulfill requirements for a 3002 unconditioned private line. Either 2 or 4 wire operation may be used. A count of block errors on the data link is reported hourly at the AMARC.

3.15 When a dedicated data link fails, the AMARC initiates a call to the dialed back-up data link (the call may be placed over the toll or local network). During the time required (about 30 seconds) call data is stored in buffers; one buffer is provided for each line finder. Few calls can be lost (unbilled) in this time. For a call to be lost, a call must disconnect and a subsequent call must be placed, answered, and disconnected on the same line finder before the automatic dialed back-up is established. Calls which pass through overtime boundaries and also disconnect while the dialed back-up call is being placed will not be billed for the overtime period.

3.16 The dialed back-up line must be arranged for terminating (receive) only service. If it is inadvertently connected to a line finder group terminal, a permanent busy condition will follow the first access.

4. DETERMINATION OF REQUIREMENTS

GENERAL

4.01 The Call Data Accumulator (CDA) equipment provided is based on the *physical amount* of line finders required for CDA operation in an office. This provision is not affected by the amount of traffic or by the engineering criteria used to determine the number of line finders to handle traffic.

EQUIPMENT PROVISION

4.02 The CDA equipment in the local office should be furnished on the following basis:

- Multiplexer—One per 248 first selectors
- Scan Control—One per 496 line finders-first selectors (One per two multiplexers)
- Line Finder Relays—One per line finder in each group equipped for CDA operation
- Identification Relay Selector—One per scan control
- Line Identification Control—One per four scan controls (only provided for ANI-C and D)

4.03 The CDA is modular in nature, allowing application over the full range of sizes of Step-by-Step offices. For planning purposes, one scan control unit and one line identification relay selector unit is required for every 496 line finders equipped. One input network and multiplexer unit is required for every 248 line finders equipped. Items to be specified in the Network Design Order are shown in Fig. 4.

4.04 An office can be partly equipped with CDA equipment. This is done by selecting enough groups of line finders to serve the measured rate traffic and equipping all line finders in those groups with CDA. However, it is still necessary to modify all of the ANI number networks for ANI-C and D, and for ANI-B if class mark diodes are used.

4.05 When an office is partly equipped, flat rate lines can be assigned in the measured rate line groups if desired for load balancing.

4.06 In order to move first selectors from measured rate line groups to flat rate line groups, it is necessary to rearrange cables that connect the tip and ring and the sleeve leads to the multiplexer (Fig. 2 and 3). Because of the expense of rearranging these cables, this is not a recommended practice.

4.07 In some instances, rearrangements cannot be avoided and in those cases the following guide lines should be considered:

(1) Existing message rate line finders may be used to create new message rate line finder groups. This assumes the sleeve relay of the new line finder location is cross-connected to agree with the first selector address.

(2) Existing message rate first selectors cannot be associated with flat rate finders unless a sleeve relay is supplied for each flat rate finder. If no relay is supplied, each answered call will result in an ANI failure. By adding a relay, and assigning this selector to a flat rate class of service, the calls will be treated by the AMARC as flat rate calls and no trouble results.

(3) A first selector without an associated line finder connected to CDA will result in an "unused scan port" printout each 24 hours at the AMARC.

(4) A first selector which is removed from the shelf, but still connected to CDA, will result in the omission of a test which is made when a

group of eight finders are idle. This test insures that a scan port is not stuck in the idle condition. The scan port in this situation indicates a reversal to the scan control circuit.

4.08 Fully equipping an office, particularly offices which can be fully equipped with only one scan control, results in simplification of engineering and installation, and lower annual charges for administration and maintenance. As a result of these factors, an office with less than 496 line finders should not, in general, be partially equipped.

4.09 The addition of line finder groups may result in an increase in the number of CDA's because of the need to locate multiplexers within 250 feet (cable length) of their associated first selectors.

4.10 The traffic capacity of a scan control, limited by the data link, is 12,400 calls per hour. This stated capacity includes the total number of answered calls for both flat and measured rate service. Calls delayed due to instantaneous overload are not lost but are marked delayed and stored by the CDA equipment. This stated capacity is well in excess of the engineered capacity of the 496 associated line finders. Therefore CDA can be considered to be terminal limited.

4.11 The Automatic Message Accounting Recording Center (AMARC) equipment can be associated with a maximum of 30 CDA scan controls for No. 1 AMARC and 90 for No. 1A AMARC.

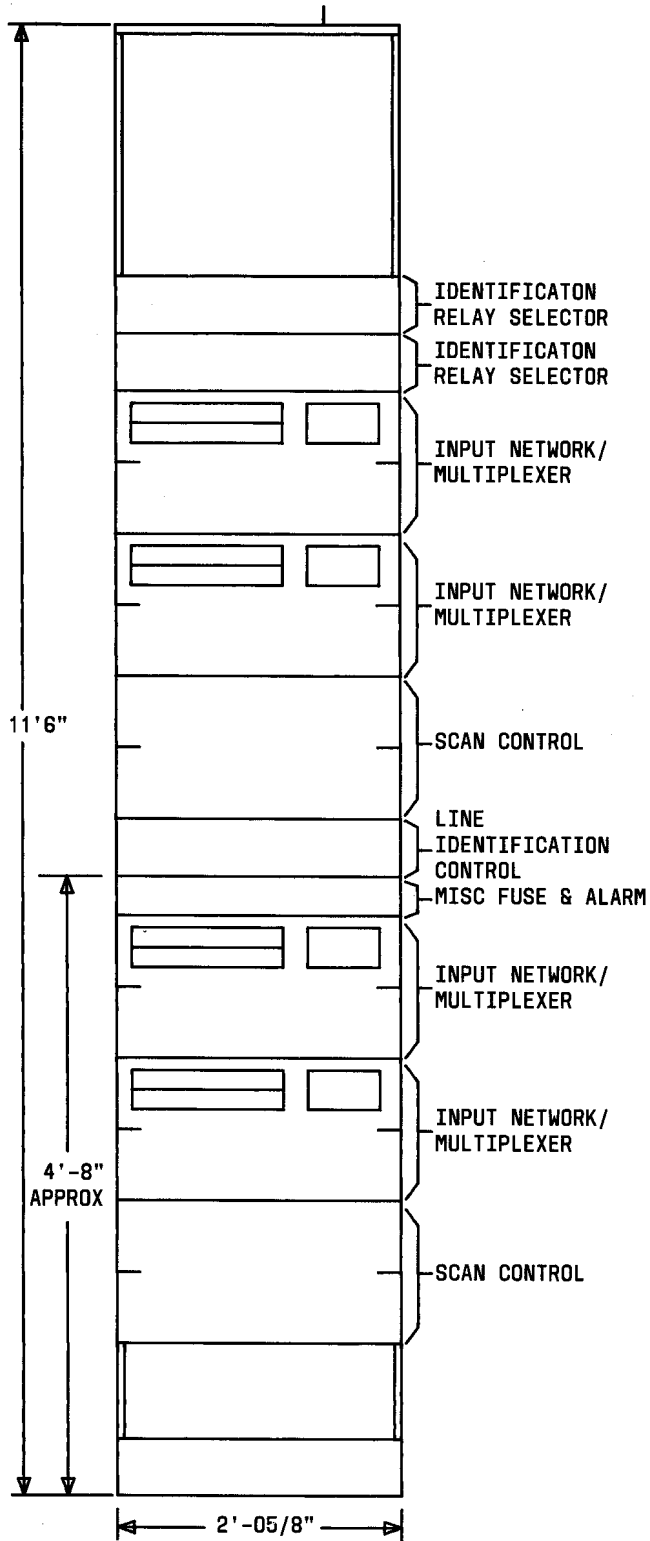

Fig. 1—Call Data Accumulator Typical Configuration (2.03)

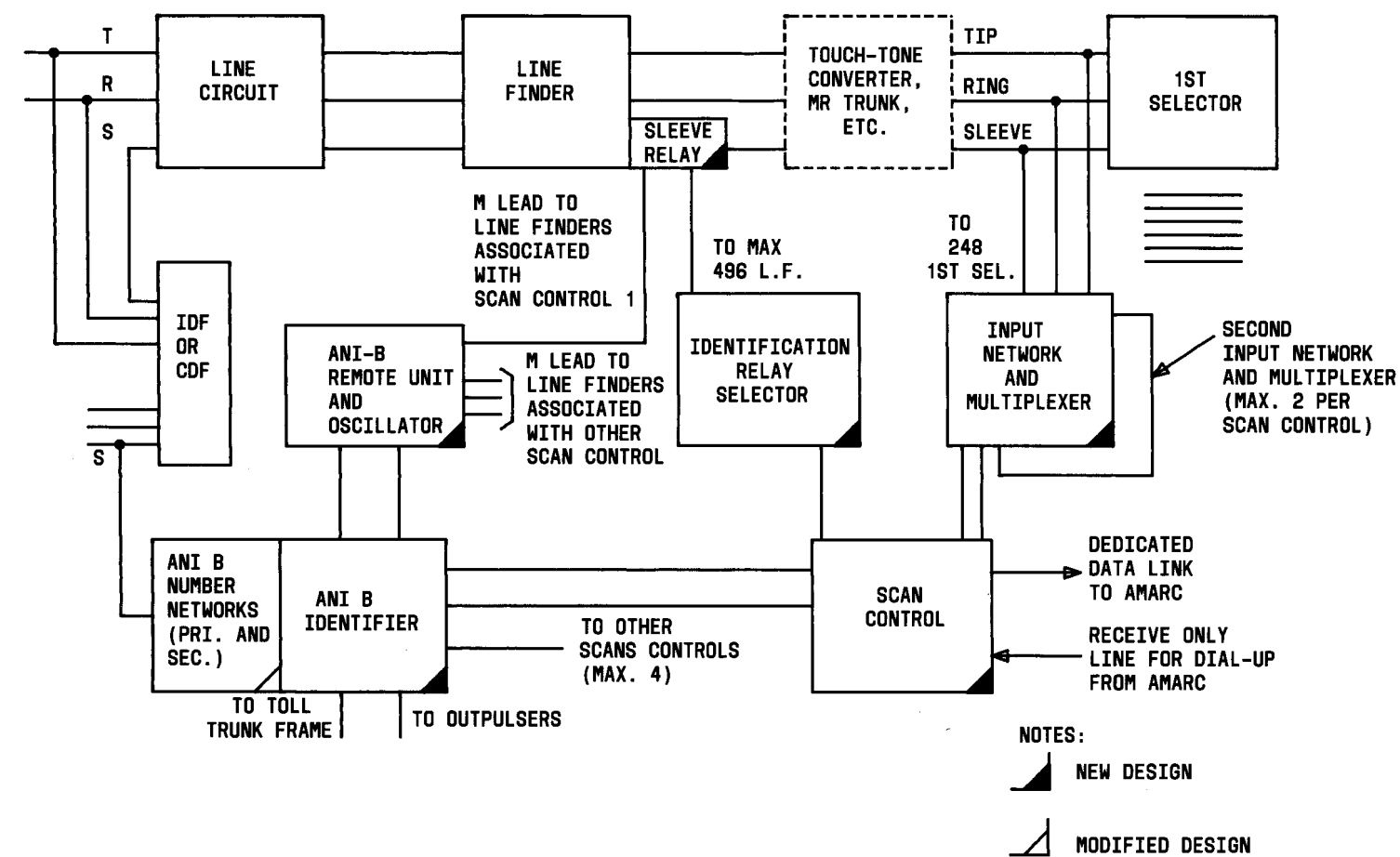

Fig. 2—Call Data Accumulator with Automatic Number Identification Type B (2.10, 4.06)

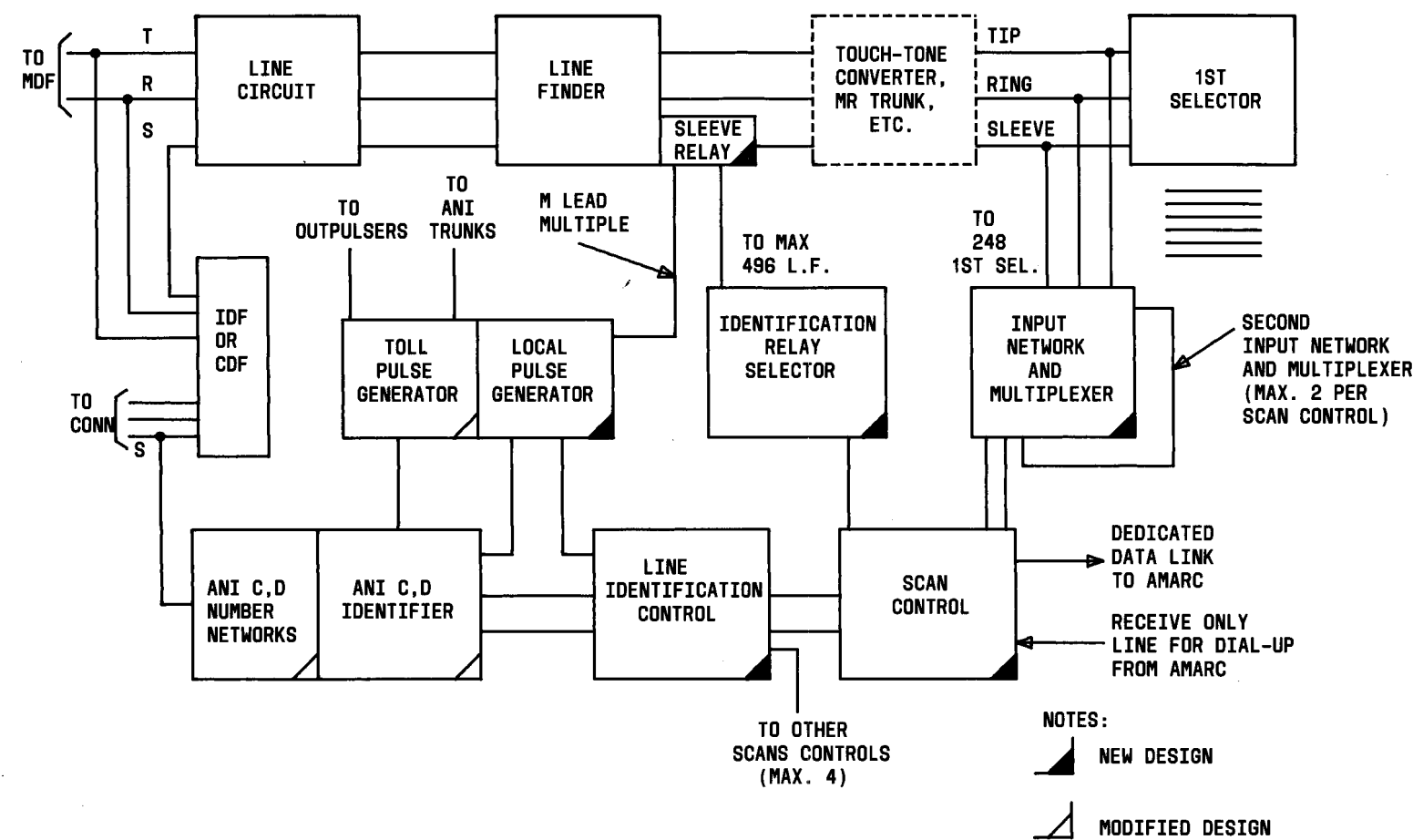

Fig. 3—Call Data Accumulator with Automatic Number Identification Types C and D (2.11, 4.06)

ITEM	MAX L F /1st Sel	BASIS OF PROVISION
Multiplexer	248	One or two per scan control
ID relay selector	496	One per scan control
Scan control	496	Serves one or two multiplexers
Line ID control (AN1 C, D)		Serves one to four scan controls
LF sleeve relays		1 per each line finder in line groups equipped for CDA
Dedicated data link		One per each scan control
Receive-only line for dialed backup from No. 1 AMARC		Provide one assigned local telephone number
ANI-B identifiers		Provide 2 new type identifiers. Replaces present type

Fig. 4—Items Specified in Network Design Order (4.03)