

8-PARTY REVERTING CALL SELECTORS
OPERATION TESTS
USING TEST SET SD-31859-01 (J34722B)
AND TEST LINES SD-31857-01 AND SD-30981-01
STEP-BY-STEP SYSTEMS

1. GENERAL

1.01 This section describes a method of testing the operating features of 8-party reverting call selectors using test set SD-31859-01 and either test line SD-31857-01 (355A offices) or SD-30981-01 (356A offices).

1.02 This section is reissued to incorporate material from the addendum in its proper location. In this process marginal arrows have been omitted.

1.03 The tests cover selector operation under loop and leak conditions, correctness and polarity of ringing codes, and test requirements of tripping relays. The test and features covered are:

(A) 8-Party Semiselective Ringing Test - Using Bells in Test Line to Indicate Ringing Signals.

(B) 8-Party Semiselective Ringing Test - Using Lamps in Test Set or Test Line to Indicate Ringing Signals.

1.04 Lettered Steps: The letters a, b, c, etc, are added to a step to indicate that the step covers an action which may or may not be required, depending on local conditions. The conditions under which a lettered step or series of steps should be made are given in the action column and all steps governed by the same condition are designated by the same letter. When a condition does not apply, the associated steps should be omitted.

1.05 Before proceeding with the tests in this section, verify that the positive and negative superimposing batteries and tripping batteries are within specified limits.

1.06 When testing reverting call selectors which have a 60- to 75-volt silent interval tripping battery and for which ac requirements are specified, any ring-trip relay which fails on test shall be readjusted to meet the requirements in Section 040-236-701 and the readjust ringing current values provided by the test line. These values are obtained by connecting the TL jack of the test set to the AC jack of the test line as shown in Fig. 1 and Table 1.

1.07 When testing reverting call selectors arranged for 1400- or 1500-ohm maximum external subscriber loops, any ring-trip relay which fails on test shall be readjusted mechanically and electrically to meet the requirements specified in Section 040-236-701 and in the circuit requirement table. Repeat the tests. If

the relay continues to fail, apply the readjust resistance values and repeat the tests, changing the tension of the No. 1 spring as required. The readjust resistance values are applied by connecting the test set TL jack to the test line ADJ jack. Where 66- to 75-volt silent interval tripping battery is used, operate the test line and test set keys as shown in Notes (a) and (b) under Table 2 to apply the silent interval test and readjust resistance values.

1.08 Local instructions should be followed with reference to recording any register operations caused by performing these tests.

1.09 These tests should preferably be made during periods of light traffic.

1.10 The test equipment specified in this section is designed to apply proper marginal tests (simulated critical circuit conditions) when the circuit under test and the test equipment have an applied voltage of 48.5 to 50. In those offices where power plants are normally operated at more than 50 volts, the battery voltage should be reduced and maintained within the required limits while the tests are being made.

2. APPARATUS

ALL TESTS

2.01 Test Set, J34722B (SD-31859-01).

2.02 No. 1011G Dial Hand Test Set, equipped with cord assembly consisting of one W2CL Cord, one No. 471A Jack, and one No. 240A Plug (No. 2W39A) or equivalent.

2.03 P3H Cord (or equivalent) equipped with No. 310 Plug and No. 240A Plug (3P2A).

2.04 Two P3E Cords, each 6 feet long, equipped with two No. 310 Plugs (3P7A).

2.05 P3E Cord, one foot long, equipped with two No. 310 Plugs (3P6A). For use when test set is provided with PTR key.

2.06 P3E Cord, 6 feet long, equipped with two No. 310 Plugs (3P7A). For use when test set is provided with NTR key. Also used when readjusting relays having ac readjust requirements.

Test (B)

2.07 P3E Cord, 6 feet long, equipped with two No. 310 Plugs. For use when test set is arranged for visual indication of ringing signals (8R jack).

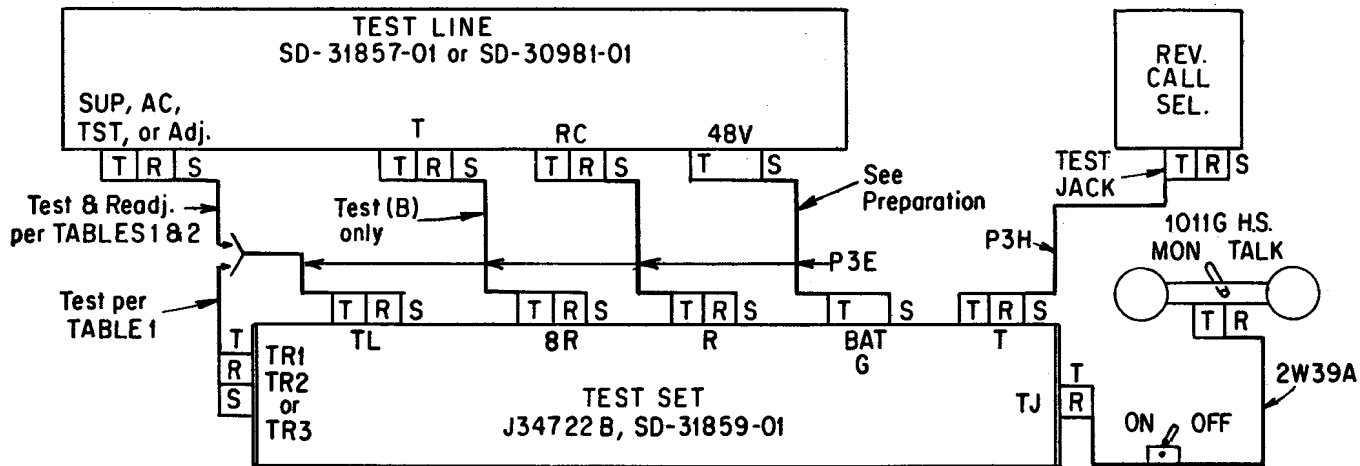

Fig.1

TABLE 1
TEST SET PROVIDED WITH PTR KEY

KIND OF RINGING	MAX. EXT. SUBS. LOOP (OHMS)	TRIPPING BATTERY (VOLTS)	CONNECT TL JACK FOR	
			TEST	READJUST
			To Test Set Jack	To Test Line Jack
SUPER-IMPOSED	750-900	60-75	TR 1	AC
	1000-1115		TR 2	
		45-52	TR 3	-

TABLE 2
TEST SET PROVIDED WITH NTR KEY

KIND OF RINGING	MAX. EXT. SUBS. LOOP (OHMS)	TRIPPING BATTERY (VOLTS)	CONNECT TL JACK FOR	
			TEST	READJUST
			To Test Line Jacks	
SUPER-IMPOSED	750 - 900	60 - 75	SUP.	AC
	1000 - 1115			-
	1400-1500	48.5 - 50	TST	ADJ.
		66-75	TST (a)	ADJ. (b)

NOTE (a): Operate ST KEY of Test Line before Silent Interval Trip Test.

NOTE (b): Make Silent Interval readjust Trip Test by operating NTR Key of Test Set.

3. PREPARATION

<u>STEP</u>	<u>ACTION</u>	<u>VERIFICATION</u>
1	Connect the dial hand test set and the test line to the test set as shown in Fig. 1 as required by Table 1 or Table 2.	
	Note: To avoid possible grounding of the battery supply lead, connect the cord to the test set first, and when disconnecting remove the cord from the test set last.	

4. METHOD

<u>STEP</u>	<u>ACTION</u>	<u>VERIFICATION</u>
	<u>(A) 8-Party Semiselective Ringing Test - Using Bells in Test Line to Indicate Ringing Signals</u>	
2	Operate BELL-R key of test line.	
3	Operate REV-CALL key.	
4	Operate switch on dial hand test set cord to OFF.	
5	Insert No. 240A plug of P3H cord into test jack of selector.	C (control) lamp does not light.
6	Operate switch on dial hand test set to TALK.	C lamp lighted.
7	Dial 11.	
8	Operate switch on dial hand test set to MON.	-R bell rings one-ring code Buzzer relay follows ringing.
9	Restore BELL-R key.	-R bells cease to sound Buzzer relay continues to following ringing.
10	Operate PTR (pretrip) or NTR (nontrip) key at start of a ringing interval and restore before end of interval.	Buzzer relay stops while key is operated.
11	Operate TR (trip) key at start of a ringing interval and restore before end of interval.	Selector releases. Buzzer relay stops. C lamp extinguished.
12	Operate switch on dial hand test set to TALK.	C lamp lighted.
13	Operate REV-L key and BELL-T key.	
14	Dial 44.	
15	Operate switch on dial hand test set to MON.	+R bells ring one-ring code. Buzzer relay follows ringing.
16	Restore BELL-T key.	+R bells cease to sound. Buzzer relay continues to follow ringing.

SECTION 226-340-509

<u>STEP</u>	<u>ACTION</u>	<u>VERIFICATION</u>
17	Operate PTR or NTR key at start of ringing interval and restore before end of this interval.	Buzzer relay stops while key is operated.
18	Operate TR key at start of ringing interval and restore before end of this interval.	Buzzer relay stops. Selector releases. C lamp extinguished.
19	Operate switch on dial hand test set to TALK.	C lamp lighted.
20	Restore REV-L key and Operate BELL-R key.	
21	Dial 33.	
22	Operate switch on dial hand test set to MON.	+R bell follows one-ring code. Buzzer relay follows ringing.
23	Restore BELL-R key	Test line bells cease to sound. Buzzer relay continues to follow ringing.
24a	If silent interval trip battery 48.5-50 volts - Operate and restore TR key during silent interval.	Selector releases. C lamp extinguished. Buzzer relay does not sound again.
25b	If silent interval trip battery is 66- to 75-volts, first operate ST key of test line, then - Operate and restore TR key during silent interval.	Selector releases. C lamp extinguished. Buzzer relay does not sound again.
26	Operate switch on dial hand test set cord to ON.	
27	Operate BELL-R key.	
28	Restore REV-CALL key and operate LEAK key.	
29	Operate switch on dial hand test set to TALK.	C lamp lighted.
30	Dial 75.	
31	Restore LEAK key and operate REV-CALL key.	
32	Operate switch on dial hand test set to MON.	-R and +R bells sound two-ring code. Buzzer relay follows ringing.
		Note: Check that first ringing signal is full two rings in order to verify the pickup feature.
33	Operate and restore TR key.	Selector releases. C lamp extinguished. Buzzer relay stops.
34	Operate REV-L key.	

<u>STEP</u>	<u>ACTION</u>	<u>VERIFICATION</u>
35	Restore BELL-R key and operate BELL-T key.	
36	Repeat Steps 28 to 33 except dial 68.	Same as Steps 28 to 33.
37	Repeat Steps 28 to 33 except dial 42.	Same as Steps 28 to 33 except +R and -R bells sound one-ring code.
38	Repeat Steps 28 to 33 except dial 82.	Same as Steps 28 to 33 except +R bells sound two-ring code and -R bells follow one-ring code.
39	Operate switch on dial hand test set to TALK.	C lamp lighted.
40	Dial nonworking terminal 89.	Selector steps to terminal dialed.
41	Operate switch on dial hand test set to MON.	Selector releases. C lamp extinguished.
42	If no other tests are to be made restore all keys and remove all cord connections.	
<u>(B) 8-Party Semiselective Ringing Test - Using Lamps in Test Set or Test Line to Indicate Ringing Signals</u>		
2c	When using test line SD-31857-01 - Operate R key of test set and connect 8R jack of test set to T jack of test line using P3E cord.	
3c	Operate TR4 key to right.	
4d	When using test line SD-30981-01 - Operate RC SEL key of test line to R position.	
5	Operate REV-CALL key.	
6	Operate switch on dial hand test set cord to OFF.	
7	Insert No. 240A plug of P3H cord into test jack of selector.	C lamp does not light.
8	Operate switch on dial hand test set to TALK.	C lamp lighted.
9	Dial 11.	
10	Operate switch on dial hand test set to MON.	(-) or -R lamp lights in response to one-ring code. Buzzer relay follows ringing.
11	Restore R key or RC SEL R key.	(-) or -R lamp extinguished. Buzzer relay continues to sound.
12e	If (-) or -R lamp does not remain extinguished - Remove and replace plug in BR jack of test set.	(-) or -R lamp extinguished. Buzzer relay continues to follow ringing.
13	Operate PTR or NTR key at start of a ringing interval and restore before end of interval.	Buzzer relay stops while key is operated.

SECTION 226-340-509

<u>STEP</u>	<u>ACTION</u>	<u>VERIFICATION</u>
14	Operate TR key at start of a ringing interval and restore before end of interval.	Selector releases. Buzzer relay stops. C lamp extinguished.
15	Operate switch on dial hand test set to TALK.	C lamp lighted.
16	Operate REV-L key and T or RC SEL T key.	
17	Dial 44.	
18	Operate switch on dial hand test set to MON.	(+) or +R lamp lights in response to one-ring code. Buzzer relay follows ringing.
19	Restore T or RC SEL T key.	(+) or +R lamp extinguished. Buzzer relay continues to follow ringing.
20e	If (+) or +R lamp does not remain extinguished - Remove and replace plug in BR jack of test set.	(+) or +R lamp extinguished. Buzzer relay continues to follow ringing.
21	Operate PTR or NTR key at start of ringing interval and restore before end of this interval.	Buzzer relay stops when key is operated.
22	Operate TR key at start of ringing interval and restore before end of this interval.	Buzzer relay stops. Selector releases. C lamp extinguished.
23	Operate switch on dial-hand test set to TALK.	C lamp lighted.
24	Restore REV-L key and operate R or RC SEL R key.	
25	Dial 33.	
26	Operate switch on dial hand test set to MON.	(+) or +R lamp lights in response to one-ring code. Buzzer relay follows ringing.
27	Restore R or RC SEL R key.	(+) or +R lamp extinguished. Buzzer relay continues to follow ringing.
28e	If (+) or +R lamp does not remain extinguished - Remove and replace plug in BR jack of test set.	(+) or +R lamp extinguished. Buzzer relay continues to follow ringing.
29a	If silent interval trip battery is 48.5- to 50-volts - Operate and restore TR key during silent interval.	Selector releases. C lamp extinguished. Buzzer relay does not sound again.
30b	If silent interval trip battery is 66- to 75-volts, first operate ST key of test line then - Operate and restore TR key during a silent interval.	Selector releases. C lamp extinguished. Buzzer relay does not sound again.
31	Operate switch on dial hand test set cord to ON.	
32	Operate R or RC SEL R key.	

<u>STEP</u>	<u>ACTION</u>	<u>VERIFICATION</u>
33	Restore REV-CALL key and operate LEAK key.	
34	Operate switch on dial hand test set to TALK.	C lamp lighted.
35	Dial 75.	
36	Restore LEAK key and operate REV-CALL key.	
37	Operate switch on dial hand test set to MON.	(-) or -R and (+) or +R lamps are lighted in response to two-ring code. Buzzer relay follows ringing. <u>Note:</u> Check that first ringing signal is full two rings to verify pickup feature.
38	Restore R or RC SEL R key.	(-) or -R lamp extinguished. Buzzer relay continues to follow ringing.
39e	If (-) or -R lamp does not remain extinguished - Remove and replace plug in BR jack.	(-) or -R lamp extinguished. Buzzer relay continues to follow ringing.
40	Operate and restore TR key.	Selector releases. C lamp extinguished. Buzzer relay stops.
41	Operate REV-L key.	
42	Operate T or RC CALL T key.	
43	Repeat Steps 29 to 34 except dial 68.	Same as Steps 29 to 34.
44	Repeat Steps 29 to 34 except dial 42.	Same as Steps 29 to 34 except lamps follow one-ring code.
45	Repeat Steps 29 to 34 except dial 82.	Same as Steps 29 to 34 except (+) or +R lamp lights in response to two-ring code and (-) or -R lights in response to one-ring code.
46	Operate switch on dial hand test set to TALK.	C lamp lighted.
47	Dial nonworking terminal 89.	Selector steps to terminal dialed.
48	Operate switch on dial hand test set to MON.	Selector releases. C lamp extinguished.
49	If no other tests are to be made restore all keys and remove all cord connections.	