

NTTMP DATA TRANSFORMATION

NETWORK TRUNK TRANSMISSION MEASUREMENT PLAN

CONTENTS	PAGE
1. GENERAL	1
2. DATA INPUT	2
3. DETAILED DATA TRANSFORMATION	2
MONTHLY REPORTED QUANTITIES	3
QUARTERLY REPORTED QUANTITIES	3
COMPOSITE INDEX AND BAND	4
HIGHER LEVEL MANAGEMENT REPORTS	4
SPECIAL RETRIEVAL	4

Figures

1. Flowchart of NTTMP Detailed Data Transformation	5
--	---

Tables

A. GUIDELINES	10
B. NTTMP INDEX TABLE C-MESSAGE NOISE, AND BALANCE	11
C. NTTMP INDEX TABLE SLOPE AND C-NOTCH NOISE	15
D. SPECIAL RETRIEVALS	19

1. GENERAL

1.01 This section provides detailed data transformation for the Network Trunk Transmission Measurement Plan (NTTMP) in the Centralized Results System (CRS). Trunk testing data summarized by a Plant Control Office (PCO) from the Centralized Automatic Reporting on Trunks (CAROT) Generic 3 (2CA3), CAROT Generic 2 (2CA2), Transmission System/Automatic Transmission Measurement System (TTS/ATMS), and manual measurements (MAN) are input via a data terminal into CRS. The CRS combines and processes these data to produce banded results by PCO for the five following characteristics:

- Loss
- C-Message Noise
- Balance
- Gain Slope
- C-Notch Noise.

Each level of management, PCO and above, receives an output report for their area of responsibility indicating the number and percentage of offices in the O (Objective), L (Less than Objective), and U (Unsatisfactory) bands. Several other quantities (not displayed on the output reports) are also calculated by CRS and stored for special retrieval if necessary (see Table D).

1.02 Whenever this section is reissued, the reason(s) for reissue will be listed in this paragraph.

1.03 Figure 1 is a flowchart of NTTMP Detailed Data Transformation within the CRS. The output reports are shown in Section 301-140-100. The CRS input procedures and data verification procedures

NOTICE

This document contains proprietary information that cannot be released outside Bell Communications Research (Bellcore) except to a regional Bell company without written permission of Bellcore.

will be specified by CRS. They are standard CRS operating procedures.

1.04 The flowchart shown in Fig. 1 is the backbone of this document. Part 2 explains the data input to CRS and Part 3 provides an explanation of the detailed data transformation as shown in Fig. 1.

2. DATA INPUT

2.01 Trunk performance, data from the four sources (MANUAL, 2CA2, 2CA3, and OTTS/ATMS) are input to CRS through data terminals. The input files are shown in the four boxes on Fig. 1, Sheet 1. The NTTMP input forms themselves are found in the following sections.

- 301-140-110 for MANUAL results
- 301-140-120 for OTTS/ATMS results
- 302-140-130 for 2CA2 results
- 301-140-140 for 2CA3 results.

2.02 Loss and C-Message noise data will be input every month. If tests were scheduled, but not completed, "NAV" should be recorded in the appropriate space on the NTTMP form. The "NAV" means the data are not available. The data will be considered as unsatisfactory and reported as a Band U on the PCO results. For components that are not required to be tested, enter the notation "E" to show an empty field. In the event that certain fields have been initialized to "E", blanks in those fields in subsequent months will continue to be treated as empty fields until the initialization is changed by entering "NAV" or numerical data. If all fields are initialized to "NAV", it is recommended that the company CRS coordinator be contacted to develop special routines to empty fields not used. For instance, if the company has all 2CA3 systems, the 2CA2 input form, NTTMP3, should be changed to empty since no input is expected. This recommendation applies to balance, gain slope and C-notch noise data as well.

2.03 Data on balance, gain slope and C-notch noise, are to be input into CRS every month or as they are available. However, these data are accumulated over a quarter and the results appear on the output reports in the last month of each quarter (i.e., March, June, September, and December). During any input period, if any of the data is unavailable for valid reasons, the respective field must be filled with an "E" for

that office to show that it is exempted from indexing for the relevant characteristic over that period. Leaving spaces blank or filling in "NAV" will result in a U band for that characteristic over that period. It should be noted that since data for these characteristics are accumulated over a quarter before processing, there may be cases where all the data are input in one or two months leaving the other one or two months with no data. In these cases "E" must be entered, in order to avoid a U band.

2.04 Input data from different test systems are combined in NTTMP. The guidelines for combining "E", "NAV", and numerical data are shown in Table A.

2.05 Combining data over a quarter is done using the same prescription: "NAV" with "E" combined or numerical data still results in "NAV" and hence a U band.

2.06 Each company using NTTMP has freedom to adopt its own mode of initialization from among the following:

- (a) Initialize based on the previous month
- (b) Initialize all blanks to empty
- (c) Initialize blanks to NAV.

This should be worked out with the CRS data base administrator.

2.07 The standard CRS input field width of 10 spaces for each column will be used for NTTMP input. The input period starts on the 23rd of each month and lasts about 10 calendar days. This is under control of each company.

3. DETAILED DATA TRANSFORMATION

3.01 Figure 1 describes in detail the various stages of data transformation starting from the CRS input data to the output reports at the office and all higher levels. Figure 1, Sheet 1, shows the input data as obtained from the four test systems. The format on this sheet corresponds to the format in the reports used to input data into CRS. For each of the five characteristics, the following notation is used:

- (a) *TKS SCHED*: The number of trunks scheduled to be tested in that month.

- (b) **MEAS SCHED**: The number of tests scheduled to be made that month (applies to balance, gain slope, and C-notch noise).
- (c) **TST SCHED**: The number of tests scheduled to be made that month (applies to balance, gain slope, and C-notch noise).
- (d) **TKS COMP**: The number of trunks actually tested over that month.
- (e) **MEAS COMP**: The number of measurements completed that month (applies to loss and C-message noise).
- (f) **TST COMP**: The number of tests completed that month (applies to balance, gain slope, and C-notch noise).
- (g) **MEAS Q1**: The number of Q1 measurements that month (i.e., measurements exceeding the maintenance limit, not the immediate action limit).
- (h) **MEAS Q2**: The number of Q2 measurements that month (i.e., measurements exceeding the immediate action limit).
- (i) **TST Q1**: The number of Q1 tests that month.
- (j) **TST Q2**: The number of Q2 tests that month.

3.02 In addition, details such as office, company, month and year are supplied during input. The numbers in parentheses corresponding to the quantities are aides in following through the calculations.

MONTHLY REPORTED QUANTITIES

3.03 Loss and C-message noise are characteristics that will generally be entered every month. Reports should be generated each month for these parameters. The processing of these data is shown on Fig. 1, Sheet 2. The quantities provided by all the tests systems are first combined across test systems (1.11). The percentage of measurements completed are computed and stored for special retrieval (1.21). The percentage of Q1 and Q2 exceptions are calculated (1.12); these are used in the Index Tables B and C to determine the Q1 and Q2 indices (1.13). The characteristic index is simply the average of the Q1 and Q2 indices (1.14) (the higher weighting for Q2s over Q1s is achieved in the index tables). The banded results for each characteristic are then achieved (1.15) by using the following translation:

INDEX	BAND
95.5	0
89.5	L
0	U

The outputs of this process are the following (each of the quantities below is calculated separately for loss and C-message noise):

- (a) **PERCENT MEAS COMP**: The percentage of measurements scheduled that are completed that month.
- (b) **Q1 PERCENT**: The percentage of Q1 measurements that month.
- (c) **Q2 PERCENT**: The percentage of Q2 measurements that month.
- (d) **Q1 INDEX**: The index corresponding to the Q1 percent determined from the Index Tables for the specific characteristic.
- (e) **Q2 INDEX**: The index corresponding to the Q2 percent, determined by using the Q2 index tables for the specific characteristic.
- (f) **INDEX**: The characteristic index, i.e., the average of the Q1 and Q2 indexes for each characteristic.
- (g) **BANDED RESULT**: The band derived from the index as above.

QUARTERLY REPORTED QUANTITIES

3.04 Every month the quarterly reported quantities (corresponding to balance, gain slope, and C-notch noise) are combined across test systems and stored (see Fig. 1, Sheet 3, 2.11). At the end of each quarter, the inputs for that quarter are summed over the three months (2.12, 2.13, 2.14, and 2.15). The percentages of tests completed (of those scheduled) are calculated and stored for special retrieval (2.21). The percentage of Q1 and Q2 exceptions for each of the characteristics is also computed (2.16). These, combined with the Index Tables, determine the index values (2.17). The Q1 and Q2 index values are averaged to determine the characteristic index for each characteristic (2.18). These are then banded (Fig. 1, Sheet 4, 2.19) using the same band boundaries as specified in

paragraph 3.03. Each of the quantities is calculated separately for balance, gain slope, and C-notch noise. The output quantities are:

- (a) **PERCENT TST COMP:** The percentage of tests scheduled that are actually completed in completed in the quarter.
- (b) **Q1 PERCENT:** The percentage of Q1 tests in that quarter.
- (c) **Q2 PERCENT:** The percentage of Q2 tests in that quarter.
- (d) **Q1 INDEX:** The index corresponding to the Q1 percent from the Index Table for the characteristic.
- (e) **Q2 INDEX:** The index corresponding to the Q2 percent, determined using the Index Tables for the relevant characteristic.
- (f) **INDEX:** The characteristic index, i.e., the average of the Q1 and Q2 indices for each characteristic.
- (g) **BANDED RESULT:** The band derived from the index calculated in (F) for each characteristic.

COMPOSITE INDEX AND BAND

3.05 A composite index is calculated every month combining all the characteristics expected to be reported that month (see Fig. 1, Sheet 4). In all months except March, June, September, and December, only Loss and C-Message Noise are combined with weights X1 and X2 (3.11). During March, June, September and December, all the five characteristics (Loss, C-Message Noise, Balance, Gain Slope, and C-Notch Noise) are combined with weights Y1, Y2, Y3, Y4, and Y5 (3.21).

The Xs and Ys are set equal to one leading to equal weighting in the CRS implementation. In general, the values assigned to them by the users may be based on the relative importance given to maintain each particular characteristic.

3.06 The composite index is banded (3.12, 3.22) using the same band boundaries as those used for the characteristic indices. The composite indices and bands are stored for special retrieval; they are not directly displayed on the output reports.

HIGHER LEVEL MANAGEMENT REPORTS

3.07 In addition to office level reports, NTTMP produces output reports for management including Manager, District, Division, General Manager, Region, and Company. These reports are generated using the process shown in Fig. 1, Sheet 5. For each characteristic, the number of offices under the manager in each of the O, L, and U bands is identified (4.11, 4.21, 4.31). The number of offices as well as the percentage of offices in each band is displayed (4.12, 4.22, 4.32). The population of offices whose combined index (for all the characteristics) lies in each of the O, L, and U bands is also calculated and stored for special retrieval.

3.08 In addition there is a Switching Control Center (SCC) manager report listing the banded result for each of the five characteristics for every office under the manager (4.40).

SPECIAL RETRIEVAL

3.09 The special retrieval, in most cases, was not considered as important for upper management as items shown on reports. For those needing special retrieval information, all such items are listed in Table D.

MANUAL

OFFICE:		FORM: NTTMP1		YEAR:	
COMPANY:		MONTH:		YEAR:	
LOSS TKS SCHED (11)	LOSS MEAS SCHED (12)	LOSS TKS COMP (13)	LOSS MEAS COMP (14)	LOSS MEAS Q ₁ (15)	LOSS MEAS Q ₂ (16)
CMN TKS SCHED (17)	CMN MEAS SCHED (18)	CMN TKS COMP (19)	CMN MEAS COMP (110)	CMN MEAS Q ₁ (111)	CMN MEAS Q ₂ (112)
BAL TKS SCHED (113)	BAL TST SCHED (114)	BAL TKS COMP (115)	BAL TST COMP (116)	BAL TST Q ₁ (117)	BAL TST Q ₂ (118)
G/S TKS SCHED (119)	G/S TST SCHED (120)	G/S TKS COMP (121)	G/S TST COMP (122)	G/S TST Q ₁ (123)	G/S TST Q ₂ (124)
CNN TKS SCHED (125)	CNN TST SCHED (126)	CNN TKS COMP (127)	CNN TST COMP (128)	CNN TST Q ₁ (129)	CNN TST Q ₂ (130)

2CA2

OFFICE:		FORM: NTTMP3		YEAR:	
COMPANY:		MONTH:		YEAR:	
LOSS TKS SCHED (161)	LOSS MEAS SCHED (162)	LOSS MEAS COMP (163)	LOSS MEAS Q ₁ (164)	LOSS MEAS Q ₂ (165)	
CMN TKS SCHED (166)	CMN MEAS SCHED (167)	CMN MEAS COMP (168)	CMN MEAS Q ₁ (169)	CMN MEAS Q ₂ (170)	
BAL TKS SCHED (171)	BAL TST SCHED (172)	BAL TST COMP (173)	BAL TST Q ₁ (174)	BAL TST Q ₂ (175)	
G/S TKS SCHED (176)	G/S TST SCHED (177)	G/S TST COMP (178)	G/S TST Q ₁ (179)	G/S TST Q ₂ (180)	
CNN TKS SCHED (181)	CNN TST SCHED (182)	CNN TST COMP (183)	CNN TST Q ₁ (184)	CNN TST Q ₂ (185)	

2CA3

OFFICE:		FORM: NTTMP2		YEAR:	
COMPANY:		MONTH:		YEAR:	
LOSS TKS SCHED (13)	LOSS MEAS SCHED (132)	LOSS TKS COMP (133)	LOSS MEAS COMP (134)	LOSS MEAS Q ₁ (135)	LOSS MEAS Q ₂ (136)
CMN TKS SCHED (137)	CMN MEAS SCHED (138)	CMN TKS COMP (139)	CMN MEAS COMP (140)	CMN MEAS Q ₁ (141)	CMN MEAS Q ₂ (142)
BAL TKS SCHED (143)	BAL TST SCHED (144)	BAL TKS COMP (145)	BAL TST COMP (146)	BAL TST Q ₁ (147)	BAL TST Q ₂ (148)
G/S TKS SCHED (149)	G/S TST SCHED (150)	G/S TKS COMP (151)	G/S TST COMP (152)	G/S TST Q ₁ (153)	G/S TST Q ₂ (154)
CNN TKS SCHED (155)	CNN TST SCHED (156)	CNN TKS COMP (157)	CNN TST COMP (158)	CNN TST Q ₁ (159)	CNN TST Q ₂ (160)

OTTS

OFFICE:		FORM: NTTMP4		YEAR:	
COMPANY:		MONTH:		YEAR:	
LOSS TKS SCHED (186)	LOSS MEAS SCHED (187)	LOSS MEAS COMP (188)	LOSS MEAS Q ₁ (189)	LOSS MEAS Q ₂ (190)	
CMN TKS SCHED (191)	CMN MEAS SCHED (192)	CMN MEAS COMP (193)	CMN MEAS Q ₁ (194)	CMN MEAS Q ₂ (195)	
BAL TKS SCHED (196)	BAL TST SCHED (197)	BAL TST COMP (198)	BAL TST Q ₁ (199)	BAL TST Q ₂ (1100)	
G/S TKS SCHED (1101)	G/S TST SCHED (1102)	G/S TST COMP (1103)	G/S TST Q ₁ (1104)	G/S TST Q ₂ (1105)	
CNN TKS SCHED (1106)	CNN TST SCHED (1107)	CNN TST COMP (1108)	CNN TST Q ₁ (1109)	CNN TST Q ₂ (1110)	

Fig. 1—Flowchart of NTTMP Detailed Data Transformation (Sheet 1 of 5) (1.03, 2.01, 3.01)

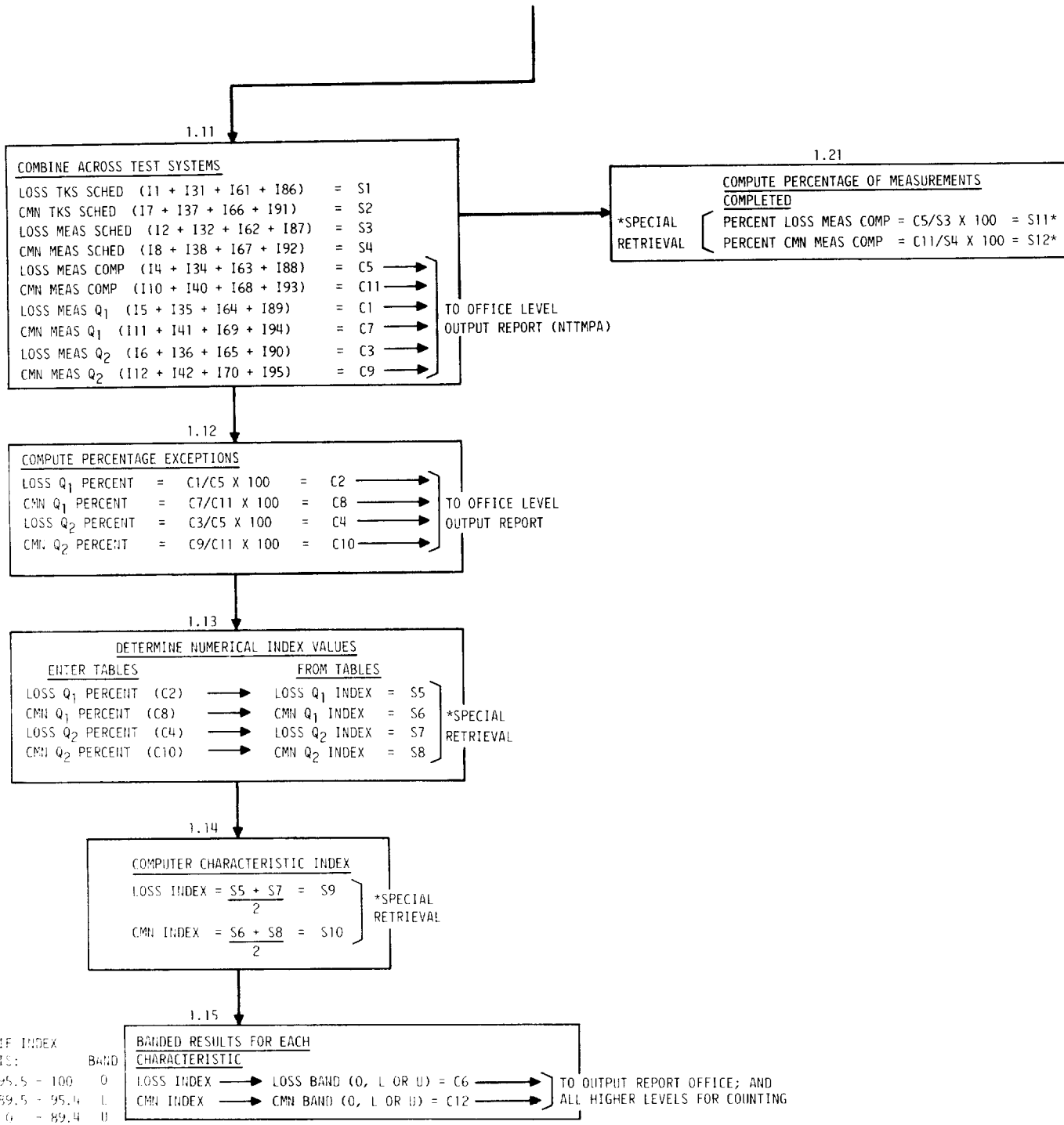
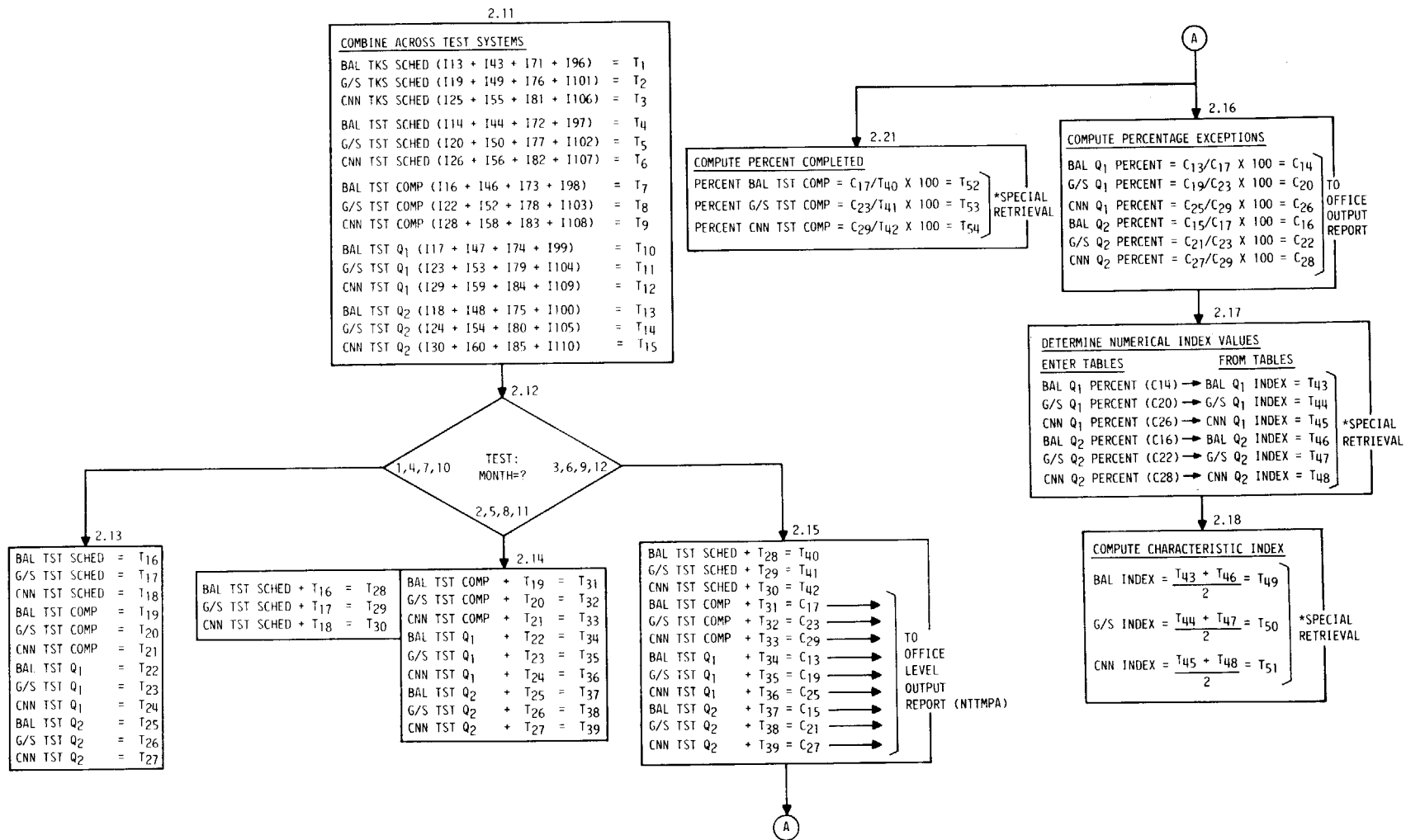

Fig. 1—Flowchart of NTTMP Detailed Data Transformation (Sheet 2 of 5) (1.04, 3.01, 3.03)



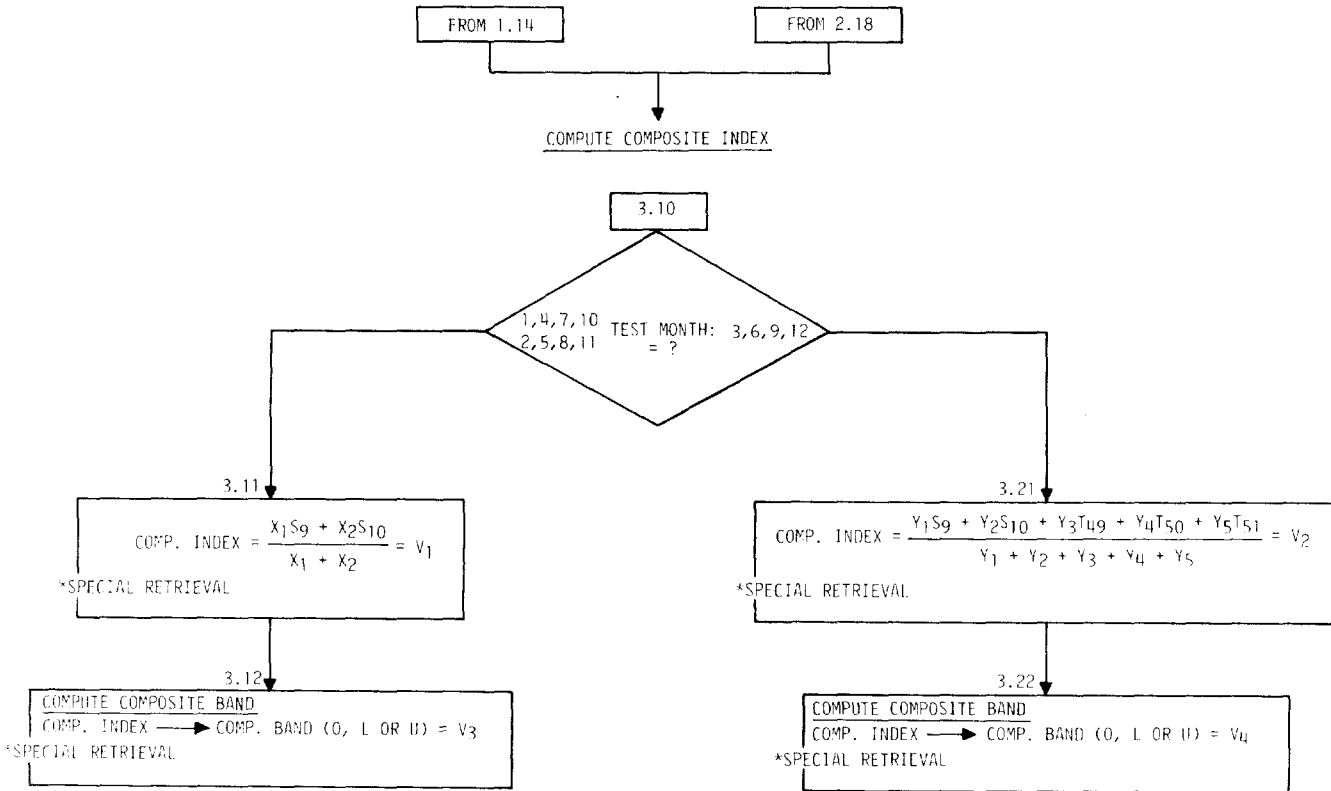
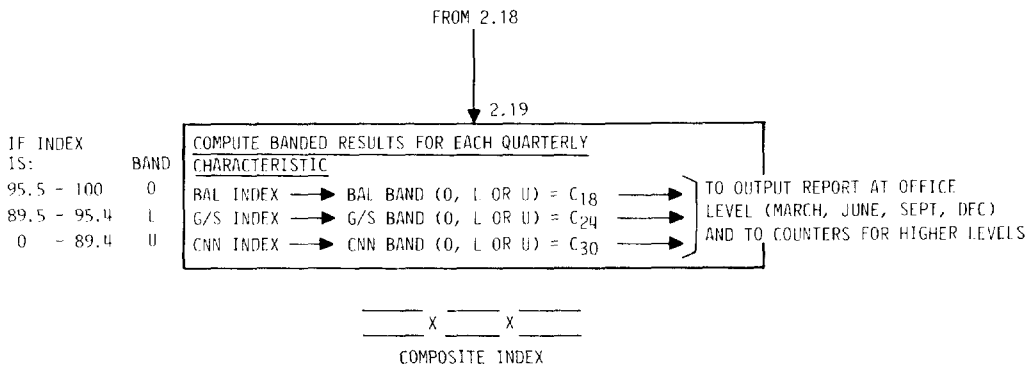

Fig. 1—Flowchart of NTTMP Detailed Data Transformation (Sheet 4 of 5) (1.04, 3.01, 3.04, 3.05)

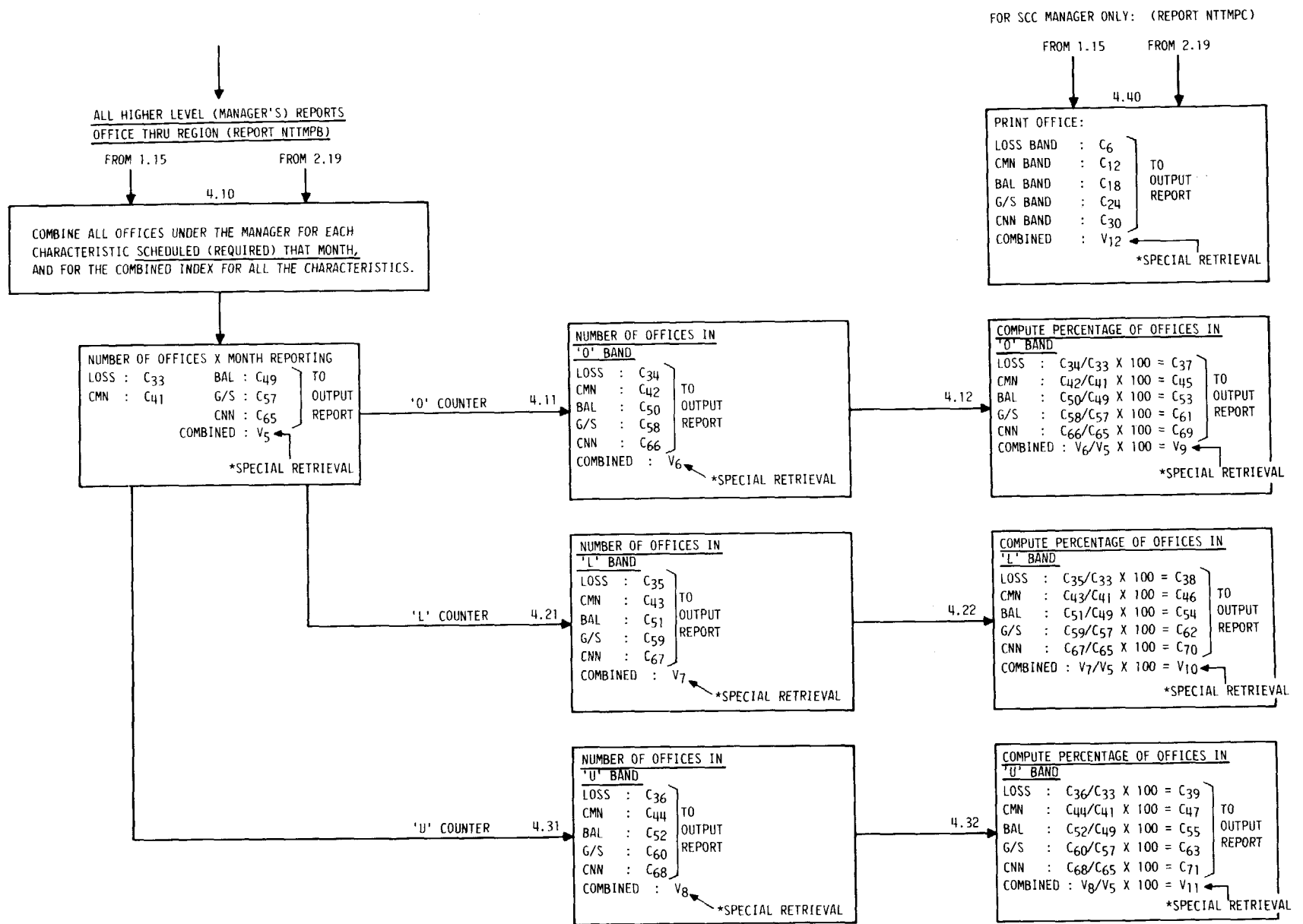

Fig. 1—Flowchart of NTTMP Detailed Data Transformation (Sheet 5 of 5) (1.04, 3.01, 3.07)

TABLE A
GUIDELINES

INPUT		OUTPUT REPORT & BAND	
TEST SYSTEM A	TEST SYSTEM B		
Nav E E NAV Numerical	E NAV Numerical Numerical NAV	NAV NAV Numerical NAV NAV	U U Banded Result U U

TABLE B

NTTMP INDEX TABLE

FOR

LOSS, C-MESSAGE NOISE, AND BALANCE

Index Value	Index Points	Q1 Performance Range (%)	Q2 Performance Range (%)
100.00	50.00	0.00 - 1.15	0.00 - .13
99.50	49.75	1.16 - 3.45	.14 - .38
99.00	49.50	3.46 - 4.78	.38 - .53
98.50	49.25	4.79 - 5.13	.54 - .58
98.00	49.00	5.14 - 5.48	.59 - .63
97.50	48.75	5.49 - 5.83	.64 - .68
97.00	48.50	5.84 - 6.10	.69 - .78
96.50	48.25	6.11 - 6.30	.79 - .93
96.00	48.00	6.31 - 6.63	.94 - 1.08
95.50	47.75	6.64 - 7.08	1.09 - 1.23
95.00	47.50	7.09 - 7.33	1.24 - 1.26
94.50	47.25	7.34 - 7.38	1.27 - 1.30
94.00	47.00	7.39 - 7.68	1.31 - 1.33
93.50	46.75	7.69 - 8.25	1.39 - 1.53
93.00	46.50	8.26 - 8.74	1.54 - 1.66
92.50	46.25	8.75 - 9.15	1.67 - 1.77
92.00	46.00	9.16 - 9.47	1.78 - 1.86
91.50	45.75	9.48 - 9.72	1.87 - 1.92
91.00	45.50	9.73 - 9.88	1.93 - 1.97
90.50	45.25	9.89 - 9.96	1.98 - 1.99
90.00	45.00	9.97 - 10.00	2.00 - 2.00
89.50	44.75	10.01 - 10.11	2.01 - 2.02
89.00	44.50	10.12 - 10.22	2.03 - 2.05
88.50	44.25	10.23 - 10.33	2.06 - 2.07
88.00	44.00	10.34 - 10.44	2.08 - 2.09
87.50	43.75	10.45 - 10.55	2.10 - 2.12
87.00	43.50	10.56 - 10.66	2.13 - 2.14
86.50	43.25	10.67 - 10.77	2.15 - 2.16
86.00	43.00	10.78 - 10.89	2.17 - 2.19
85.50	42.75	10.90 - 11.00	2.20 - 2.21
85.00	42.50	11.01 - 11.11	2.22 - 2.23
84.50	42.25	11.12 - 11.22	2.24 - 2.26
84.00	42.00	11.23 - 11.33	2.27 - 2.28
83.50	41.75	11.34 - 11.44	2.29 - 2.30
83.00	41.50	11.45 - 11.55	2.31 - 2.33
82.50	41.25	11.56 - 11.66	2.34 - 2.35
82.00	41.00	11.67 - 11.77	2.36 - 2.38
81.50	40.75	11.78 - 11.88	2.39 - 2.40
81.00	40.50	11.89 - 11.99	2.41 - 2.42
80.50	40.25	12.00 - 12.10	2.43 - 3.45
80.00	40.00	12.11 - 12.21	2.46 - 2.47
79.50	39.75	12.22 - 12.32	2.48 - 2.49
79.00	39.50	12.33 - 12.43	2.50 - 2.52
78.50	39.25	12.44 - 12.54	2.53 - 2.54
78.00	39.00	12.55 - 12.66	2.55 - 2.56
77.50	38.75	12.67 - 12.77	2.57 - 2.59

TABLE B
NTTMP INDEX TABLE
FOR

LOSS, C-MESSAGE NOISE, AND BALANCE

Index Value	Index Points	Q1 Performance Range (%)	Q2 Performance Range (%)
77.00	38.50	12.78 - 12.88	2.60 - 2.61
76.50	38.25	12.89 - 12.99	2.62 - 2.63
76.00	38.00	13.00 - 13.10	2.64 - 2.66
75.50	37.75	13.11 - 13.21	2.67 - 2.68
75.00	37.50	13.22 - 13.32	2.69 - 2.70
74.50	37.25	13.33 - 13.43	2.71 - 2.73
74.00	37.00	13.44 - 13.54	2.74 - 2.75
73.50	36.75	13.55 - 13.65	2.76 - 2.77
73.00	36.50	13.66 - 13.76	2.78 - 2.80
72.50	36.25	13.77 - 13.87	2.81 - 2.82
72.00	36.00	13.88 - 13.98	2.83 - 2.84
71.50	35.75	13.99 - 14.09	2.85 - 2.87
71.00	35.50	14.10 - 14.20	2.88 - 2.89
70.50	35.25	14.21 - 14.31	2.90 - 2.91
70.00	35.00	14.32 - 14.43	2.92 - 2.94
69.50	34.75	14.44 - 14.54	2.95 - 2.96
69.00	34.50	14.55 - 14.65	2.97 - 2.98
68.50	34.25	14.66 - 14.76	2.99 - 3.01
68.00	34.00	14.77 - 14.87	3.02 - 3.03
67.50	33.75	14.88 - 14.98	3.04 - 3.05
67.00	33.50	14.99 - 15.09	3.06 - 3.08
66.50	33.25	15.10 - 15.20	3.09 - 3.10
66.00	33.00	15.21 - 15.31	3.11 - 3.13
65.50	32.75	15.32 - 15.42	3.14 - 3.15
65.00	32.50	15.43 - 15.53	3.16 - 3.17
64.50	32.25	15.54 - 15.64	3.18 - 3.20
64.00	32.00	15.65 - 15.75	3.21 - 3.22
63.50	31.75	15.76 - 15.86	3.23 - 3.24
63.00	31.50	15.87 - 15.97	3.25 - 3.27
62.50	31.25	15.98 - 16.08	3.28 - 3.29
62.00	31.00	16.09 - 16.20	3.30 - 3.31
61.50	30.75	16.21 - 16.31	3.32 - 3.34
61.00	30.50	16.32 - 16.42	3.35 - 3.36
60.50	30.25	16.43 - 16.53	3.37 - 3.38
60.00	30.00	16.54 - 16.64	3.39 - 3.41
59.50	29.75	16.65 - 16.75	3.42 - 3.43
59.00	29.50	16.76 - 16.86	3.44 - 3.45
58.50	29.35	16.87 - 16.97	3.46 - 3.48
58.00	29.00	16.98 - 17.08	3.49 - 3.50
57.50	28.75	17.09 - 17.19	3.51 - 3.52
57.00	28.50	17.20 - 17.30	3.53 - 3.55
56.50	28.25	17.31 - 17.41	3.56 - 3.57
56.00	28.00	17.42 - 17.52	3.58 - 3.59
55.50	27.75	17.53 - 17.63	3.60 - 3.62
55.00	27.50	17.64 - 17.74	3.63 - 3.64
54.50	27.25	17.75 - 17.85	3.65 - 3.66
54.00	27.00	17.86 - 17.97	3.67 - 3.69

TABLE B
NTTMP INDEX TABLE

FOR

LOSS, C-MESSAGE NOISE, AND BALANCE

Index Value	Index Points	Q1	Q2
		Performance Range (%)	Performance Range (%)
53.50	26.75	17.98 - 18.08	3.70 - 3.71
53.00	26.50	18.09 - 18.19	3.72 - 3.73
52.50	26.25	18.20 - 18.30	3.74 - 3.76
52.00	26.00	18.31 - 18.41	3.77 - 3.78
51.50	25.75	18.42 - 18.52	3.79 - 3.80
51.00	25.50	18.53 - 18.63	3.81 - 3.83
50.50	25.25	18.64 - 18.74	3.84 - 3.85
50.00	25.00	18.75 - 18.85	3.86 - 3.88
49.00	24.50	18.86 - 19.07	3.89 - 3.92
48.00	24.00	19.08 - 19.29	3.93 - 3.97
47.00	23.50	19.30 - 19.51	3.98 - 4.02
46.00	23.00	19.52 - 19.74	4.03 - 4.06
45.00	22.50	19.75 - 19.96	4.07 - 4.11
44.00	22.00	19.97 - 20.18	4.12 - 4.16
43.00	21.50	20.19 - 20.40	4.17 - 4.20
42.00	21.00	20.41 - 20.62	4.21 - 4.25
41.00	20.50	20.63 - 20.84	4.26 - 4.30
40.00	20.00	20.85 - 21.06	4.31 - 4.34
39.00	19.50	21.07 - 21.28	4.35 - 4.39
38.00	19.00	21.29 - 21.51	4.40 - 4.44
37.00	18.50	21.52 - 21.73	4.45 - 4.48
36.00	18.00	21.72 - 21.95	4.49 - 4.53
35.00	17.50	21.96 - 22.17	4.54 - 4.58
34.00	17.00	22.18 - 22.39	4.59 - 4.63
33.00	16.50	22.40 - 22.61	4.64 - 4.67
32.00	16.00	22.62 - 22.83	4.68 - 4.72
31.00	15.50	22.84 - 23.05	4.73 - 4.77
30.00	15.00	23.06 - 23.28	4.78 - 4.81
29.00	14.50	23.29 - 23.50	4.82 - 4.86
28.00	14.00	23.51 - 23.72	4.87 - 4.91
27.00	13.50	23.73 - 23.94	4.92 - 4.95
26.00	13.00	23.95 - 24.16	4.96 - 5.00
25.00	12.50	24.17 - 24.38	5.01 - 5.05
24.00	12.00	24.39 - 24.60	5.06 - 5.09
23.50	11.50	24.61 - 24.82	5.10 - 5.14
22.00	11.00	24.83 - 25.05	5.15 - 5.19
21.00	10.50	25.06 - 25.27	5.20 - 5.23
20.00	10.00	25.28 - 25.49	5.24 - 5.28
19.00	9.50	25.50 - 25.71	5.29 - 5.33
18.00	9.00	25.72 - 25.93	5.34 - 5.38
17.00	8.50	25.94 - 26.15	5.39 - 5.42
16.00	8.00	26.16 - 26.37	5.43 - 5.47
15.00	7.50	26.38 - 26.59	5.48 - 5.52
14.00	7.00	26.60 - 26.82	5.53 - 5.56
13.00	6.50	26.83 - 27.04	5.57 - 5.61
12.00	6.00	27.05 - 27.26	5.62 - 5.66
11.00	5.50	27.27 - 27.48	5.67 - 5.70

TABLE B
NTTMP INDEX TABLE
FOR

LOSS, C-MESSAGE NOISE, AND BALANCE

Index Value	Index Points	Q1 Performance Range (%)	Q2 Performance Range (%)
10.00	5.00	27.49 - 27.70	5.71 - 5.75
9.00	4.50	27.71 - 27.92	5.76 - 5.80
8.00	4.00	27.93 - 28.14	5.81 - 5.84
7.00	3.50	28.15 - 28.36	5.85 - 5.89
6.00	3.00	28.37 - 28.59	5.90 - 5.94
5.00	2.50	28.60 - 28.81	5.95 - 5.98
4.00	2.00	28.82 - 29.03	5.99 - 6.03
3.00	1.50	29.04 - 29.25	6.04 - 6.08
2.00	1.00	29.26 - 29.47	6.09 - 6.13
1.00	.50	29.48 - 29.69	6.14 - 6.17

TABLE C
NTTEMP INDEX TABLE

FOR

GAIN SLOPE AND C-NOTCH NOISE

Index Value	Index Points	Q1 Performance Range (%)	Q2 Performance Range (%)
77.00	38.50	19.36 - 19.53	3.90 - 3.93
76.50	38.25	19.54 - 19.70	3.94 - 3.96
76.00	38.00	19.71 - 19.87	3.97 - 4.00
75.50	37.75	19.88 - 20.05	4.01 - 4.03
75.00	37.50	20.06 - 20.22	4.04 - 4.07
74.50	37.25	20.23 - 20.40	4.08 - 4.18
74.00	37.00	20.41 - 20.57	4.11 - 4.14
73.50	36.75	20.58 - 20.74	4.25 - 4.18
73.00	36.50	20.75 - 20.92	4.19 - 4.21
72.50	36.25	20.93 - 21.09	4.22 - 4.25
72.00	36.00	21.10 - 21.27	4.26 - 4.28
71.50	35.75	21.28 - 21.44	4.29 - 4.32
71.00	35.50	21.45 - 21.61	4.33 - 4.35
70.50	35.25	21.62 - 21.79	4.36 - 4.39
70.00	35.00	21.80 - 21.96	4.40 - 4.43
69.50	34.75	21.97 - 22.14	4.44 - 4.46
69.00	34.50	22.15 - 22.31	4.47 - 4.50
68.50	34.25	22.32 - 22.48	4.51 - 4.53
68.00	34.00	22.49 - 22.66	4.54 - 4.57
67.50	33.75	22.67 - 22.83	4.58 - 4.60
67.00	33.50	22.84 - 23.01	4.61 - 4.64
66.50	33.25	23.02 - 23.18	4.65 - 4.67
66.00	33.00	23.19 - 23.36	4.68 - 4.71
65.50	32.75	23.37 - 23.53	4.72 - 4.75
65.00	32.50	23.54 - 23.70	4.76 - 4.78
64.50	32.25	23.71 - 23.88	4.79 - 4.82
64.00	32.00	23.89 - 24.05	4.83 - 4.85
63.50	31.75	24.06 - 24.23	4.86 - 4.89
63.00	31.50	24.24 - 24.40	4.90 - 4.92
62.50	31.25	24.41 - 24.57	4.93 - 4.96
62.00	31.00	24.58 - 24.75	4.97 - 5.00
61.50	30.75	24.76 - 24.92	5.01 - 5.03
61.00	30.50	24.93 - 25.10	5.04 - 5.07
60.50	30.25	25.11 - 25.27	5.08 - 5.10
60.00	30.00	25.28 - 25.44	5.11 - 5.14
59.50	29.75	25.45 - 25.62	5.15 - 5.17
59.00	29.50	25.63 - 25.79	5.18 - 5.21
58.50	29.25	25.80 - 25.97	5.22 - 5.24
58.00	29.00	25.98 - 26.14	5.25 - 5.28
57.50	28.75	26.15 - 26.31	5.29 - 5.32
57.00	28.50	26.32 - 26.49	5.33 - 5.35
56.50	28.25	26.50 - 26.66	5.36 - 5.39
56.00	28.00	26.67 - 26.84	5.40 - 5.42
55.50	27.75	26.85 - 27.01	5.43 - 5.46
55.00	27.50	27.02 - 27.18	5.47 - 5.49
54.50	27.25	27.19 - 27.36	5.50 - 5.53
54.00	27.00	27.37 - 27.53	5.54 - 5.57

TABLE C

NTTEMP INDEX TABLE

FOR

GAIN SLOPE AND C-NOTCH NOISE

Index Value	Index Points	Q1 Performance Range (%)	Q2 Performance Range (%)
100.00	50.00	0.00 - 1.08	0.00 - .15
99.50	49.75	1.09 - 3.23	.16 - .45
99.00	49.50	3.24 - 4.80	.46 - .73
98.50	49.25	4.81 - 5.80	.74 - .98
98.00	49.00	5.81 - 6.45	.99 - 1.18
97.50	48.75	6.46 - 6.75	1.19 - 1.33
97.00	48.50	6.76 - 7.45	1.34 - 1.45
96.50	48.25	7.46 - 8.55	1.46 - 1.55
96.00	48.00	8.56 - 9.53	1.56 - 1.70
95.50	47.75	9.54 - 10.38	1.71 - 1.90
95.00	47.50	10.39 - 10.98	1.91 - 2.03
94.50	47.25	10.99 - 11.33	2.04 - 2.08
94.00	47.00	11.34 - 11.88	2.09 - 2.20
93.50	46.75	11.80 - 12.65	2.21 - 2.40
93.00	46.50	12.66 - 13.30	2.41 - 2.56
92.50	46.25	13.31 - 13.85	2.57 - 2.70
92.00	46.00	13.86 - 14.29	2.71 - 2.82
91.50	45.75	14.30 - 14.62	2.83 - 2.90
91.00	45.50	14.63 - 14.84	2.91 - 2.96
90.50	45.25	14.85 - 14.95	2.97 - 2.99
90.00	45.00	14.96 - 15.00	3.00 - 3.00
89.50	44.75	15.01 - 15.17	3.01 - 3.04
89.00	44.50	15.18 - 15.35	3.05 - 3.07
88.50	44.25	15.36 - 15.52	3.08 - 3.11
88.00	44.00	15.53 - 15.70	3.12 - 3.14
87.50	43.75	15.71 - 15.87	3.15 - 3.18
87.00	43.50	15.88 - 16.04	3.19 - 3.21
86.50	43.25	16.05 - 16.22	3.22 - 3.25
86.00	43.00	16.23 - 16.39	3.26 - 3.29
85.50	42.75	16.40 - 16.57	3.30 - 3.32
85.00	42.50	16.58 - 16.74	3.33 - 3.36
84.50	42.25	16.75 - 16.91	3.37 - 3.39
84.00	42.00	16.92 - 17.09	3.40 - 3.43
83.50	41.75	17.10 - 17.26	3.44 - 3.46
83.00	41.50	17.27 - 17.44	3.47 - 3.50
82.50	41.25	17.45 - 17.61	3.51 - 3.53
82.00	41.00	17.62 - 17.79	3.54 - 3.57
81.50	40.75	17.80 - 17.96	3.58 - 3.61
81.00	40.50	17.97 - 18.13	3.62 - 3.64
80.50	40.25	18.14 - 18.31	3.65 - 3.68
80.00	40.00	18.32 - 18.48	3.69 - 3.71
79.50	38.75	18.49 - 18.66	3.72 - 3.75
79.00	39.50	18.67 - 18.83	3.76 - 3.78
78.50	39.25	18.84 - 19.00	3.79 - 3.82
78.00	39.00	19.01 - 19.18	3.83 - 3.86
77.50	38.75	19.19 - 19.35	3.87 - 3.89

TABLE C

NTTEMP INDEX TABLE

FOR

GAIN SLOPE AND C-NOTCH NOISE

Index Value	Index Points	Q1	Q2
		Performance Range (%)	Performance Range (%)
53.50	26.75	27.54 - 27.71	5.58 - 5.60
53.00	26.50	27.72 - 27.88	5.61 - 5.64
52.50	26.25	27.89 - 28.05	5.65 - 5.67
52.00	26.00	28.06 - 28.23	5.68 - 5.71
51.50	25.75	28.24 - 28.40	5.72 - 5.74
51.00	25.50	28.41 - 28.58	5.75 - 5.78
50.50	25.25	28.59 - 28.75	5.79 - 5.81
50.00	25.00	28.76 - 28.93	5.82 - 5.85
49.00	24.50	28.94 - 29.27	5.86 - 5.92
48.00	24.00	29.28 - 29.62	5.93 - 5.99
47.00	23.50	29.63 - 29.97	6.00 - 6.06
46.00	23.00	29.98 - 30.32	6.07 - 6.14
45.00	22.50	30.33 - 30.67	6.15 - 6.21
44.00	22.00	30.68 - 31.01	6.22 - 6.28
43.00	21.50	31.02 - 31.36	6.29 - 6.35
42.00	21.00	31.37 - 31.71	6.36 - 6.42
41.00	20.50	31.72 - 32.06	6.43 - 6.49
40.00	20.00	32.07 - 32.41	6.50 - 6.56
39.00	19.50	32.42 - 32.75	6.57 - 6.63
37.00	18.50	33.11 - 33.45	6.64 - 6.78
36.00	18.00	33.46 - 33.80	6.79 - 6.85
35.00	17.50	33.81 - 34.15	6.86 - 6.92
34.00	17.00	34.16 - 34.50	6.93 - 6.99
33.00	16.50	34.51 - 34.84	7.00 - 7.06
32.00	16.00	34.85 - 35.19	7.07 - 7.13
31.00	15.50	35.20 - 35.54	7.14 - 7.20
30.00	15.00	35.55 - 35.89	7.21 - 7.28
29.00	14.50	35.90 - 36.24	7.29 - 7.35
28.00	14.00	36.25 - 36.58	7.36 - 7.42
27.00	13.50	36.59 - 36.93	7.43 - 7.49
26.00	13.00	36.94 - 37.28	7.50 - 7.56
25.00	12.50	37.29 - 37.63	7.57 - 7.63
24.00	12.00	37.64 - 37.93	7.64 - 7.70
23.00	11.50	37.99 - 38.32	7.71 - 7.77
22.00	11.00	38.33 - 38.67	7.78 - 7.85
21.00	10.50	38.68 - 39.02	7.86 - 7.92
20.00	10.00	39.03 - 39.37	7.93 - 7.99
19.00	9.50	39.38 - 39.72	8.00 - 8.06
18.00	9.00	39.73 - 40.07	8.07 - 8.13
17.00	8.50	40.08 - 40.41	8.14 - 8.20
16.00	8.00	40.42 - 40.76	8.21 - 8.27
15.00	7.50	40.77 - 41.11	8.28 - 8.34
14.00	7.00	41.12 - 41.46	8.35 - 8.42
13.00	6.50	41.47 - 41.81	8.43 - 8.49
12.00	6.00	41.82 - 42.15	8.50 - 8.56
11.00	5.50	42.16 - 42.50	8.57 - 8.63
10.00	5.00	42.51 - 42.85	8.64 - 8.70

TABLE C
NTTMP INDEX TABLE (SHEET 4 OF 4)
FOR
GAIN SLOPE AND C-NOTCH NOISE

Index Value	Index Points	Q1	Q2
		Performance Range (%)	Performance Range (%)
9.00	4.50	42.86 - 43.20	8.71 - 8.77
8.00	4.00	43.21 - 43.55	8.78 - 8.84
7.00	3.50	43.56 - 43.89	8.85 - 8.91
6.00	3.00	43.90 - 44.24	8.92 - 8.99
5.00	2.50	44.25 - 44.59	9.00 - 9.06
4.00	2.00	44.60 - 44.94	9.07 - 9.13
3.00	1.50	44.95 - 45.29	9.14 - 9.20
2.00	1.00	45.30 - 45.64	9.21 - 9.27
1.00	.50	45.65 - 45.98	9.28 - 9.34

TABLE D
SPECIAL RETRIEVALS

CODE	REPORT
S5	Loss, Q1 Index
S6	C-Message Noise, Q1 Index
S7	Loss, Q2 Index
S8	C-Message Noise, Q2 Index
	(S5+S7)
S9	Loss Index $\frac{\quad}{2}$
	(S6+S8)
S10	C-Message Noise Index $\frac{\quad}{2}$
S11	Percent Loss Measurements Complete
S12	Percent C-Message Noise Measurements Complete
T43	Balance, Q1 Index
T44	Gain Slope, Q1 Index
T45	C-Notch Noise, Q1 Index
T46	Balance Q2 Index
T47	Gain Slope, Q2 Index
T48	C-Notch Noise, Q2 Index
	(T43+T46)
T49	Balance Index $\frac{\quad}{2}$
	(T44+T47)
T50	Gain Slope Index $\frac{\quad}{2}$
	(T45+T48)
T51	C-Notch Noise Index $\frac{\quad}{2}$
T52	Percent Balance Test Complete
T53	Percent Gain Slope Test Complete
T54	Percent C-Notch Noise Test Complete
V1	Composite Index -- Nonquarterly
V2	Composite Index -- Quarterly -- All 5 characteristics
V3	Composite Band -- Nonquarterly
V4	Composite Band -- Quarterly -- All 5 characteristics
V5	Number of Offices for the Manager -- Combined
V6	Number of Offices in "O" Band -- Combined
V7	Number of Offices in "L" Band -- Combined
V8	Number of Offices in "U" Band -- Combined
V9	Percentage of Offices in "O" Band -- Combined
V10	Percentage of Offices in "L" Band -- Combined
V11	Percentage of Offices in "U" Band -- Combined
V12	SCC Manager Combined (V3 or V4)