

19A TESTBOARD

MEASUREMENT AND ADJUSTMENT OF PADS FOR THE TRANSMISSION MEASURING CIRCUIT

CONTENTS	PAGE
1. GENERAL	1
2. TESTS REQUIRED TO DETERMINE PAD VALUES	1
A. Tests to Determine Values of Pads Associated with TST MEAS Jacks	2
B. Adjustment of Pads in TST MEAS Circuit	4
C. Tests to Determine Values of Pads Associated with 101 MEAS Jacks	4
D. Adjustment of Pads in 101 MEAS Circuit	5
E. Tests to Determine Values of Pads Associated with SUB MEAS Jacks	6
F. Adjustment of Pads in SUB MEAS Circuit	6

1. GENERAL

1.01 When transmission measurements are made on network trunks, access lines, and subscriber lines at 4-wire No. 5 crossbar offices the 19A testboard measuring circuits compensate for the wiring losses associated with the testboard multiples of the trunks, subscriber lines and the 101 trunk and avoid an unwanted bias which would otherwise show up in the measurements. To accomplish this, the transmission and noise measuring circuit per SD-95900-01 is used. Fig. 3 of this section shows a Simplified Diagram of the Transmission Measuring Circuit. This section describes the procedure for adjusting the pads in the transmission measuring paths for compensating for office wiring and equipment losses.

1.02 The transmission measuring circuit contains three sets of adjustable pads, one of which is used during measurements from the "TST" multiples of the network trunks, another

during measurements over the code 101 testboard trunk and the third during measurements to subscriber lines. The test circuit terminates in three jacks designated TST MEAS, SUB MEAS and 101 MEAS. A key located in the multiple is operated to TST when a measurement is being made over the TST multiple of a network trunk and to 101 when measuring over the 101 trunk. When the key is normal, the set is arranged for tests on subscriber lines. A lever type key, located in the keyshelf to the left of the existing keys, is operated to SEND or RCV depending upon whether it is desired to send test power or to measure received test power.

1.03 The TST-101 key connects the transmission measuring circuit to the TST MEAS, SUB MEAS or 101 MEAS jacks through the desired appropriate pads, depending on the operation of the key. The pads in the three paths have the same nominal loss, 2 db, but are individually adjustable to compensate for office wiring and equipment loss. The loss of the pad in the TST MEAS path is increased or decreased from the nominal value to compensate for the difference in level between the testboard TST jack, and the trunk link frame appearances of the trunks. The loss of the pad in the 101 MEAS path is reduced from the nominal value to compensate for the loss of the 101 trunk. The loss of the pad in the SUB MEAS path is increased from the nominal value to compensate for the loss between the LOOP jacks (testboard) and the line link appearance of the subscriber lines.

1.04 All trunks are measured in their terminal conditions, i.e., with nominal 2 db pads to make testing compatible with present standard procedures.

2. TESTS REQUIRED TO DETERMINE PAD VALUES

2.01 In order to determine the amount of loss to be included in the adjustable pads associated with the TST MEAS jacks, measure-

ments are made as described below on a representative sample of network trunks. These trunks are chosen so that the longest and shortest paths between the trunk distributing frame and the testboard are included and also the longest and shortest paths between the trunk distributing frame and the trunk link frames of the 4-wire No. 5 crossbar switching equipment. For the pads associated with the 101 MEAS jacks, measurements should be made on all code 101 trunks, and each 101 trunk should be measured from both extreme testboard positions at which it is multiplied. For pads associated with the SUB MEAS jacks, measurements should be made, as described below on subscriber lines, of the loss between the DROP MON jacks and the line link frame appearance. The lines measured should include those having the shortest and longest cable runs between the testboard and the line link frame.

2.02 One value each for the TST MEAS and SUB MEAS and 101 MEAS pads will be used for a testboard, the value being based on the average of the measurements described herein. However, if there is more than one testboard lineup, separate pad values should be determined and used for each lineup. If it is found that the spread of the measurements is 0.2 db or more, between positions in one testboard lineup the reason should be determined and corrected.

2.03 If the office layout is changed, check tests should be made on a representative sample of network trunks and/or subscriber lines to determine whether the test pad values need to be changed. It is important that these pads be maintained at their proper values to provide adequate measurement accuracy.

2.04 Tests are described below for determining the pad values. Forms in this section shown as A, B, and C should be prepared locally to assist in making tests and in computing the required pad values.

2.05 Apparatus Required

- 2 — Switch Boxes per Fig. 1, attached (to be assembled locally).
- 1 — 22A Milliwatt Reference Meter or Equivalent.
- 1 — 338A plug.
- 2 — 2W 17A cords equipped with KS-6278 connector clips.

2.06 Make sure that the milliwatt appearances which will be used in the following tests have been adjusted to 0 ± 0.03 dbm using the 22A milliwatt reference meter or equivalent. Make any necessary adjustments in the transmission measuring system to provide a reading of *exactly* 0 dbm when the "CAL" key is operated.

Note: It is important that the transmission measuring system to be used in these tests shall have been checked for tracking and that the meter reads within ± 0.05 db of the actual level in the neighborhood of 2 db.

2.07 For these tests, a communication channel is required between the testboard and the link frames of the 4-wire No. 5 crossbar machine.

A. Tests to Determine Values of Pads Associated with TST MEAS Jacks	
STEP	PROCEDURE
1	<p>The procedure is to measure the difference in loss from a common point such as the circuit patch bay jack, to the "TST" jack and to the trunk link frame appearance of each trunk, using the arrangements shown in Fig. 2.</p> <p>Select several network trunks whose outward appearances are distributed over the entire length of the trunk link frames and also over the testboard positions. The trunks are chosen, taking into account the office layout so as to cover the range of cable lengths to the trunk link frames and testboard positions.</p>

STEP	PROCEDURE
2	Take these trunks out of service and make them busy at both ends. The E and M leads to the signaling circuit at the near end should be opened at the circuit patch bay to avoid a false incoming signal at the distant end.
3	Check the MW appearances and the transmission measuring system per Par. 2.06.
4	Connect the two switch boxes in tandem, with the 2-wire terminals of the first connected to a 1-MW appearance (1000, 0, 600) at the circuit patch bay and the 2-wire terminals of the second connected to the 22A milliwatt reference meter or equivalent. See Fig. 2A.
5	With the keys of both switch boxes on T-R, record the reading of the 22A meter. Check this reading with the keys on T1-R1. Both readings should be the same.
6	Connect the 4-wire jacks of the first switch box with the calibrated MW appearance to the DROP side of one of the selected trunks at the circuit patch bay. See Fig. 2B.
7	Connect the 4-wire jacks of the second switch box with the 22A meter to the terminals of the same trunk at the trunk link frame. See Fig. 2B.
8	Measure and record on Form A the received level at the trunk link frame, corrected for the initial reading of the 22A meter (Step 5) with the keys in both switch boxes operated to T-R and then to T1-R1. These readings give the loss in each side of the trunk between the trunk link switch and the circuit patch bay.
9	Repeat Steps 6, 7, and 8 with each of the other selected trunks. This involves shifting the switch box at both ends to the new trunk.
10	Disconnect the 4-wire jacks of the second switch box from the trunk link switch and connect them to the TST jack of one of the selected trunks at the 19A testboard. See Fig. 2B.
11	Measure and record on Form A, the received level at the TST jack corrected for the initial reading of the 22A meter (Step 5) with the keys in both of the switch boxes operated to T-R and then to T1-R1. These readings give the loss in each side of the trunk between the TST jack and the circuit patch bay.
12	Repeat Step 11 for each of the other selected trunks. This involves shifting the switch box at both ends to a new trunk.
	The following computations are made using the Form A.
13	For each of the trunks measured, compute the difference in loss in each side of the trunk from the circuit patch bay to the TST jack (Step 11) and to the trunk link switch (Step 8). If measurement (Step 11) is higher than that of (Step 8), use a minus (-) sign for the difference. If the difference for each side of a given trunk differs by more than 0.1 db, the cause should be determined and corrected.
14	Compute the average of these differences, taking into account the sign.
15	The average computed above is the amount to be added to 2 db to determine the value of the transmitting pad and the receiving pad. If the results are negative the pad values will be less than 2 db by these amounts.

B. Adjustment of Pads in TST MEAS Circuit	
STEP	PROCEDURE
	The pads are adjusted as described below, using the results of the above tests.
16	Check the MW and transmission measuring system per Par. 2.06.
17	Patch from the TST MEAS jack to the input of the 22A meter. With the TST-101 key operated to TST, operate the SEND-RCV key to SEND, read the 22A meter and compare the reading with the computed value obtained in Step 15. If the measurement is not within ± 0.05 db of the value in Step 15 adjust the pad in the transmitting path of the TST MEAS circuit until the 22A meter reading is within ± 0.05 db of the desired value. Adjust the pad in the receiving path of the TST MEAS circuit to the same value. <i>Note:</i> A guide to the amounts of loss for the various pad strappings is given in SD-95900-01, Table C.
18	Check the pad in the receiving path of the TST MEAS circuit by operating TST-101 key to TST, the SEND-RCV key to RCV. Patch between the MW jack appearance (1000, 0, 600) and the TST MEAS jack with a pair of testboard test cords, all cord keys normal. Read the meter of the testboard transmission measuring system, and compare it with the measurement in Step 15. If the measurement is not within ± 0.05 db of the value in Step 15 a check should be made of the testboard transmission measuring system and/or the pad in the receiving path of the TST MEAS circuit to determine and correct the cause.
19	Repeat the above procedure, Steps 16 to 18 inclusive at each testboard position.
C. Tests to Determine Values of Pads Associated with 101 MEAS Jacks	
STEP	PROCEDURE
1	Check the MW appearances and the transmission measuring system per Par. 2.06.
2	Connect the 22A meter to the TMS terminals of the switch box per Fig. 1. Operate the key of the switch box to T-R and patch the T-R jack of the switch box to the calibrated MW appearance. Record the reading of the 22A meter. Check this reading with the MW appearance (1000, 0, 600) of the testboard patched to the T1-R1 jack of the switch box and the key operated to T1-R1. These readings should be the same. This switch box will comprise the receiving circuit of Fig. 2D (switch box No. 2).
3	Take one of the 101 trunks out of service and make it busy.
4	Connect the switch box No. 2 with the 22A meter to the 101 trunk at the line link frame.
5	With the key of the switch box operated to T-R patch the calibrated MW appearance to the T jack of the 101 trunk appearance at the testboard position nearest (electrically) to the line link frame. Read the 22A meter, correct for the initial reading of the 22A meter (Step 2), and record the value on Form B.

STEP	PROCEDURE
6	Operate the switch box key to T1-R1 and patch from the MW appearance to the R jack of the same 101 trunk appearance. Read the 22A meter, correct for the initial reading of the 22A meter (Step 2), and record the value on Form B.
7	Repeat Steps 5 and 6 at the multiplied appearance of the same 101 trunk which is farthest (electrically) from the line link frame.
8	Restore the 101 trunk under test to service and repeat Steps 3-7, inclusive, for the remainder of the 101 trunks.
9	Average the readings obtained from measuring on the T-R leads (transmitting) and on the T1-R1 leads (receiving). If the readings for each side of a given trunk differ by more than 0.1 db the cause should be determined and corrected.
10	Subtract each of the averages computed above from (nominal value) 2 db to determine the values of the pads in the transmitting and receiving sides of the 101 MEAS jack circuit. The actual value of the pad will always be less than 2 db.
D. Adjustment of Pads in 101 MEAS Circuit	
STEP	PROCEDURE
11	Check the MW appearances and the transmission measuring system per Par. 2.06.
12	<p>Patch from the 101 MEAS jack to the input of the 22A meter. With the TST-101 key operated to 101, operate the SEND-RCV key to SEND, read the 22A meter and compare the reading with the computed value obtained in Step 10. If the measurement is not within ± 0.05 db of the value in Step 10 adjust the pad in the transmitting path of the 101 MEAS circuit until the 22A meter reading is within ± 0.05 db of Step 10. Adjust the pad in the receiving path of the 101 MEAS circuit to the same value.</p> <p><i>Note:</i> A guide to the amounts of loss for the various pad strappings is given in SD-95900-01, Table C.</p>
13	<p>A check of the pad in the receiving path of the 101 MEAS circuit should be made as follows:</p> <p>With the TST-101 key operated to 101, the SEND-RCV key to RCV patch from the MW appearance to the 101 MEAS jack using a pair of testboard cords with all cord keys normal. Read the meter of the testboard transmission measuring system and compare the reading with the measured value obtained in Step 12. If the measurement is not within ± 0.05 db of the value in Step 12 a check should be made of the testboard transmission system and/or the pad in the receiving path of the 101 MEAS to determine and correct the cause.</p>
14	Repeat the above procedure, Steps 11-13 inclusive, at each testboard position.

E. Tests to Determine Values of Pads Associated with Sub MEAS Jacks	
STEP	PROCEDURE
1	Check the MW appearances and the transmission measuring system per Par. 2.06.
2	Connect the 22A meter to the TMS terminals of the switch box shown in Fig. 1. Patch from the T-R jack of the switch box to the calibrated milliwatt appearance (1000, 0, 600) at the testboard. Operate the switch box key to T-R. Record the reading of the 22A meter. Check this reading with the MW appearance patched to the T1-R1 jack of the switch box and the key operated to T1-R1. Both readings should be the same. This switch box will comprise the receiving circuit of Fig. 2C (switch box No. 2).
3	Take one of the SUB. lines out of service and make it busy.
4	At the Link Link Frame. Connect switch box with the 22A meter at the selected SUB. line, line link appearance per Fig. 2C.
5	At the 19A testboard. With the switch box key operated to T-R patch the calibrated MW appearance to the DROP MON jack of the selected Subscriber line. Insert a 338A opening plug in the loop jack. Record the 22A meter reading, (corrected for the initial reading in Step 2) on Form C.
6	Transfer the MW appearance to the DROP MON jack and operate the switch box key to T1-R1, read the 22A meter and record the measurement (corrected for the initial measurement in Step 2) on Form C.
7	Repeat Steps 3 to 6 for other Subscriber lines to cover a range of variations of the Subscriber line loss in the section between the DROP MON jack and the line link frame.
8	Restore the SUB. lines to service.
9	Calculate the average of the readings separately for the T-R and T1-R1 measurements. If both measurements on a given subscriber line are not within 0.1 db the cause should be determined and corrected.
10	The average represents the amount by which the 2 db transmitting and receiving pads in the SUB MEAS path of the test circuit should be increased. These values plus 2 db are the values of the pads in the SUB MEAS circuit.
F. Adjustment of Pads in SUB MEAS Circuit	
STEP	PROCEDURE
11	Check the MW appearances and the Transmission Measuring System per Par. 2.06.
12	Patch from the SUB MEAS jack to the input of the 22A meter. With the TST-101 key operated to NORMAL, (i.e., to SUB MEAS), operate the SEND-RCV key to SEND, read the 22A meter and compare the reading with the computed value obtained in Step 10. If the measurement is not within ± 0.05 db of the value in Step 10, adjust the pad in the transmitting path of the SUB MEAS circuit until the 22A meter reading is within ± 0.05 db of the desired value. Adjust the pad in the receiving path of the SUB MEAS circuit to the same value. <i>Note:</i> A guide to the amounts of loss for the various pad strappings is given in SD-95900-01, Table C.

STEP	PROCEDURE
13	Check the pad in the receiving path of the SUB MEAS circuit by operating the TST-101 key to NORMAL, (i.e., SUB MEAS) and the SEND-RCV key to RCV. Patch from the MW jack to the SUB MEAS jack with a pair of test cords, all cord keys normal. Read the meter of the testboard transmission measuring system, and compare it with the measurement in Step 12. If the measurement is not within ± 0.05 db of the value in Step 12 a check should be made of the testboard transmission measuring system and/or the pad in the receiving path of the SUB MEAS circuit to determine and correct the cause.
14	Repeat the above procedure, Steps 11 to 13 inclusive at each testboard position.

<p style="text-align: center;">DATA SHEET DETERMINATION OF PAD VALUES FOR 19A TESTBOARD PADS ASSOCIATED WITH "TEST MEAS" JACKS</p>										
Trunk Designation	Test-board Position	Designation at Trunk Link Frame	Loss Between Circuit Patch Bay and Trunk Link Switch		Loss Between Circuit Patch Bay and "TST" Jack		* (1)-(3) (5)	* (2)-(4) (6)	** PAD VALUES	
			Transmit T1-R1 (1)	Receive T-R (2)	Transmit T1-R1 (3)	Receive T-R (4)			Trans.	Rec.
<p>*Use Minus (-) sign where (3) exceeds (1) or (4) exceeds (2) **Algebraic Sum of 2 db plus the corresponding average in Col. (5) or (6)</p>										

Sample Form A

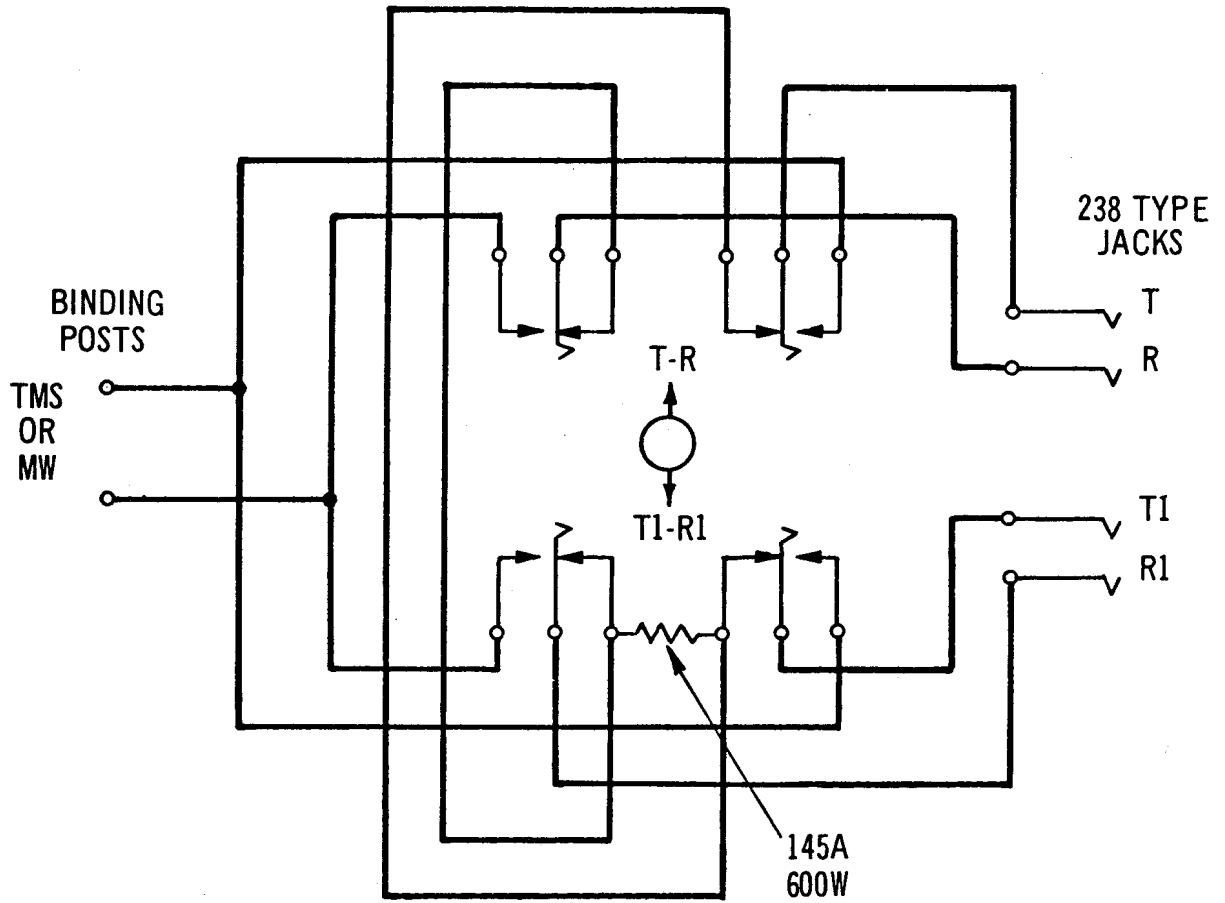

Fig. 1 - 19A Testboard — Switch Box for Connecting TMS Equipment at 4-Wire No. 5 Crossbar Systems

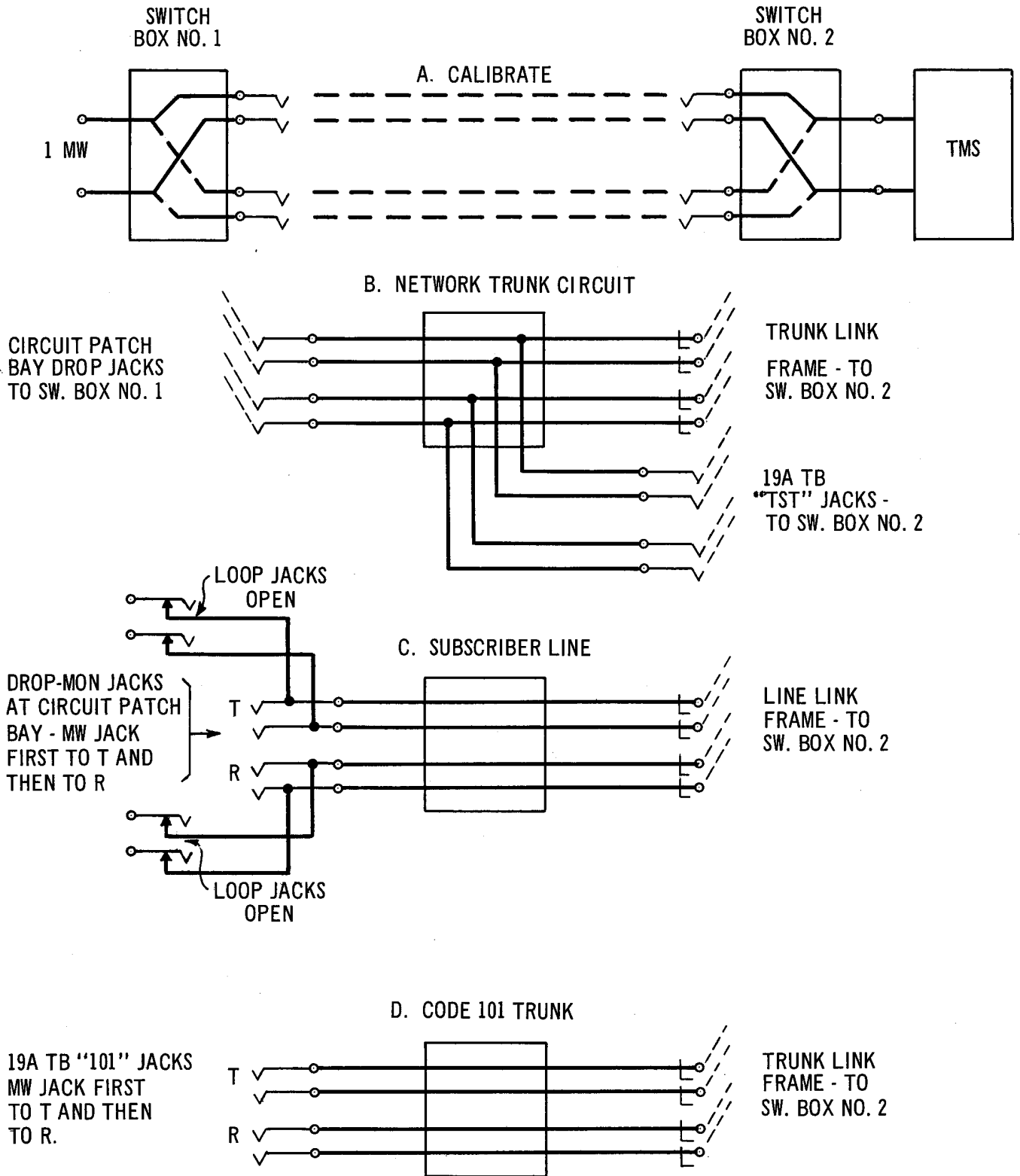
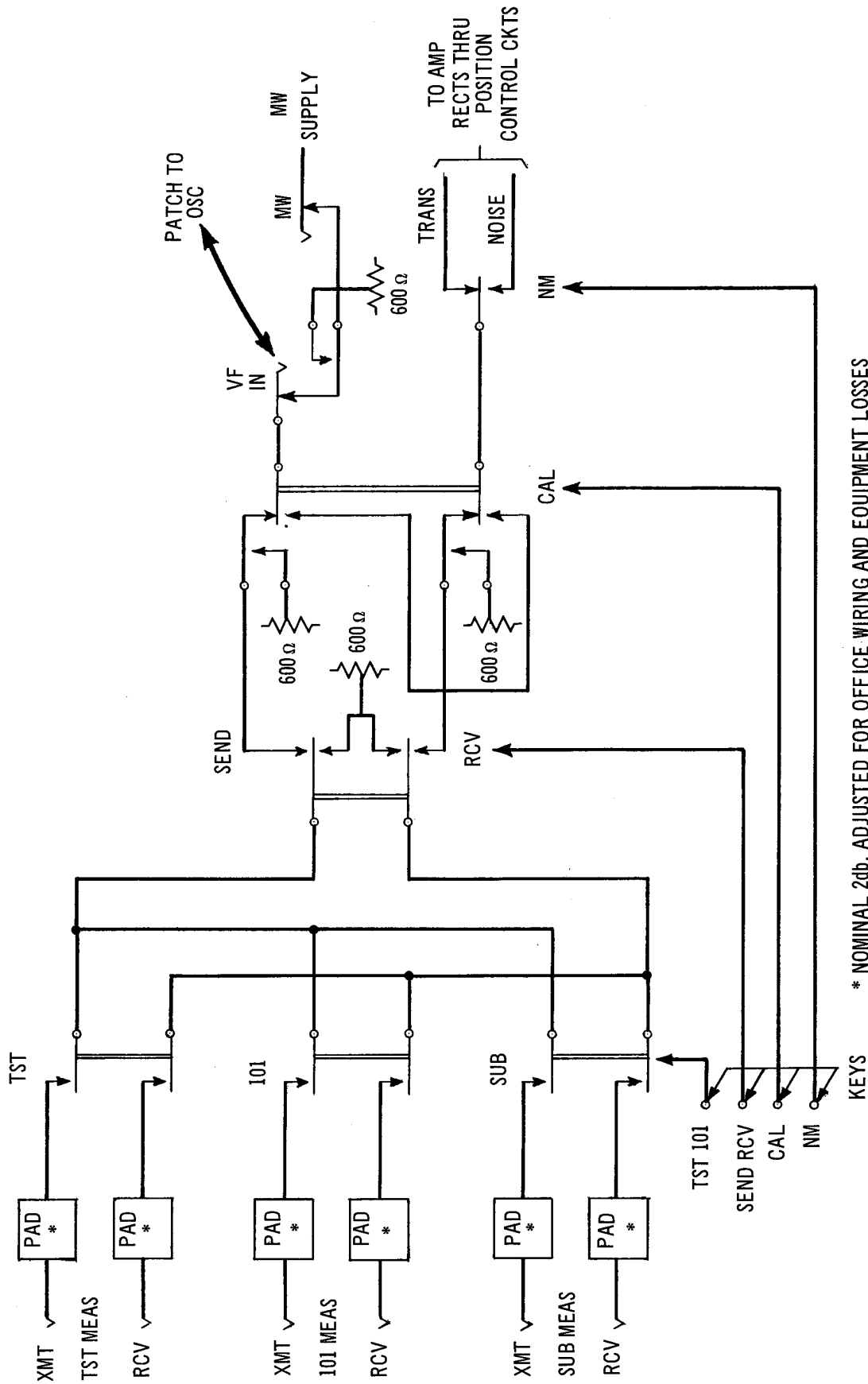

Fig. 2 - Switch Box Connections for Measurement of Pad Adjustments



* NOMINAL 2db, ADJUSTED FOR OFFICE WIRING AND EQUIPMENT LOSSES

Fig. 3 — Simplified Diagram of Transmission and Noise Measuring Circuits per SD-95900-01 — 19A Testboard (single line per pair)