

19A TESTBOARD

MEASUREMENT OF OFFICE LOSSES AT 1 KC

RELATIVE ENVELOPE DELAY AND FREQUENCY RESPONSE MEASUREMENTS

CONTENTS	PAGE
1. GENERAL	1
2. OFFICE LOSSES AT 1 KC	1
A. Measurement and Adjustment of Office Losses in Network Trunks and Access Lines	2
B. Measurement and Adjustment of Office Losses in Subscriber Lines (Equipped with E and M Leads)	6
3. RELATIVE ENVELOPE DELAY AND FREQUENCY RESPONSE	7
4. PRECUTOVER SIGNALING AND SUPERVISION TESTS	10

1. GENERAL

1.01 This section describes procedures for making measurements and adjustments of losses in office wiring at 1000 cps and for making relative envelope delay and frequency response measurements in office wiring for reference purposes. Measurements are made from a 19A testboard in a 4-wire No. 5 crossbar office.

1.02 This section has been reissued to include procedures for making relative envelope delay and frequency response measurements. The title has been extended to reflect the broadened scope of the section. Since this reissue covers a general revision, arrows ordinarily used to indicate changes have been omitted.

1.03 Losses at 1000 cps are measured between the SD-95900-01 transmission and noise measuring system, at the testboard, and the vf

patch bay or repeater bay. When the transmit (P_T) and receive (P_R) pads have been properly adjusted, correct transmission levels are established at the input to the carrier facility, in the transmitting direction, and at the switch terminals in the receiving direction.

1.04 Frequency response and relative envelope delay measurements are made between voiceband gain and delay measuring sets at the testboard and at the equalizer bay. These measurements are made to determine what part of distortions indicated in test measurements on lines and network trunks is attributable to office wiring and testboard circuits.

2. OFFICE LOSSES AT 1 KC

2.01 The P_T and P_R pads should be adjusted only by the procedures described in this section. No adjustment of these pads should be made to compensate for overall losses, since such adjustments may cover up maladjustment of the facility or of pads in the distant office.

2.02 Pads located in the measuring circuits of the SD-95900-01 transmission and noise measuring system must be adjusted by procedures described in Section 310-280-300 before making the measurements and adjustments described in this section.

2.03 Where permanently mounted SF signaling units are used, the loss in the receiving path of the unit, at 1000 cycles, should be carefully adjusted to 0 db, just prior to these tests. Refer to the appropriate section.

SECTION 310-280-500

2.04 Where plug-in SF signaling units are used, these units should be removed and replaced by a zero loss connector while making measurements in the *receiving paths only*. Use a KS-16370, L3 connector to replace a transistorized signaling unit and use a KS-14160 connector to replace an electron tube signaling unit. Terminals of the connectors must be strapped as follows:

KS-16370; L3; M to U, S to V.

KS-14160; 0 to 6, 1 to 7.

2.05 In all cases, the signaling units should be left in place while making measurements in the transmitting paths.

2.06 A typical arrangement for terminating trunks in the incoming or outgoing direction is shown in Fig. 1. Also shown is a loop-around arrangement which may be used to put the transmission and signaling circuits into the same final state in which they are normally placed on a completed call. The arrangement should be used only for setting up the test conditions and should not be used during actual transmission measurements. If this loop-around arrangement is not available, assistance is required from the distant office. The testing effort is confined, as much as possible, to the local office when these tests are made on a precutover basis, in advance of overall measurements with the distant office.

2.07 All test power outlets to be used should be checked using a 22A milliwatt reference meter, or equivalent, in accordance with the procedure given in Section 103-335-512.

2.08 The calibration of the SD-95900-01 transmission and noise measuring system should be checked before making transmission measurements. A calibration procedure is given in Section 310-281-501.

Apparatus Required

2.09 The apparatus listed below may be required for making the tests described in this section, depending upon local conditions.

2 — Voice Frequency Amplifiers (if loop-around arrangement is used)

1 — KS-14160 Connector (zero loss plug for replacing plug-in electron tube SF signaling units)

1 — KS-16370, L3 Connector (zero loss plug for replacing plug-in transistorized SF signaling units)

1 — 22A Milliwatt Reference Meter

2 — 25A Voiceband Gain and Delay Measuring Sets

3 — 600-Ohm Terminations

Note: A transmission measuring set (TMS) such as the 21A TMS or an oscillator such as the KS-19260 or KS-19357 is required to provide 1000-cps test power at +7 dbm if a 1000/+7/600 jack is not provided at the vf patch bay or repeater bay.

A. Measurement and Adjustment of Office Losses in Network Trunks and Access Lines

2.10 When tests are to be made on a network trunk that is in service, the trunk should be removed from service at each end until testing is completed. The MOD IN and DEMOD OUT jacks of the carrier channel should be terminated in 600 ohms during the tests. If an incoming trunk is also used in the test, similar treatment is required at the near end.

STEP	PROCEDURE
	<p>Outgoing Measurement and Adjustment of Office Losses</p> <p><i>Note:</i> Before beginning the test, make sure that test power outlets have been checked, that the transmission and noise measuring system has been calibrated, and that assigned circuit equipment is in place. The P_T and P_R pads must be equipped with 89-type resistors when measurements are made. If no previous adjustment has been made, a computed value may be used.</p> <p>1 Remove the outgoing trunk from service, if required. Terminate the MOD IN and DEMOD OUT jacks (vf patch or repeater bay) using 600-ohm terminations. If the loop-around arrangement shown in Fig. 1 is being used, remove the incoming trunk from service also and provide similar terminations.</p> <p>2 At the vf patch bay, make patch A to the outgoing trunk being tested and make patch B to the incoming trunk. Refer to Fig. 1.</p> <p>3 At the testboard, seize the outgoing trunk. With the TALK-MON key operated to TALK, insert a TST cord into the trunk TST jack and operate the SEIZE key.</p> <p>4 When the cord supervisory lamp is lighted, pulse forward code 101. When pulsing is completed, depress the ST key.</p> <p>5 Answer the incoming call at the testboard using the CONN cord of a separate cord pair. Connect the CONN cord to the 101 trunk jack. The answer lamp is extinguished.</p> <p>6 When an off-hook signal is observed on the TST cord supervisory lamp (lamp is extinguished), connect the associated CONN cord to the TST-MEAS jack. Operate the TST-101 key to the TST position.</p> <p>7 Return the TALK-MON key to the normal position.</p> <p>8 At the vf patch bay, remove the A and B patches. Terminate the EQ IN jack of the trunk under test, using a 600-ohm termination.</p> <p>9 Using a 2-conductor patch cord, connect the EQ OUT jack of the trunk under test to the TST 600Ω jack.</p> <p>10 At the testboard, operate the SEND-RCV key to SEND.</p> <p>11 Operate the B+10 sensitivity key and observe the reading indicated on the measuring system meter. The difference between the value indicated and -16 dbm (or other value specified for the office) is the change in the loss of the P_T pad which must be made. If a change is required, replace the 89-type resistor with one which will bring the meter indication as close as possible to -16 dbm (± 0.13 db). If a change of more than 1 db from the computed loss for the P_T pad is necessary, investigation should be made for trouble in equipment components.</p> <p><i>Note:</i> If a plug-in SF signaling unit is used in the trunk under test, replace the unit with a zero loss connector, see 2.04. If a permanently mounted SF signaling unit is used, see 2.03.</p>

STEP	PROCEDURE
12	At the vf patch bay, disconnect the patch cord from the EQ OUT and TST 600 Ω jacks. Remove the termination from the EQ IN jack and insert it into the EQ OUT jack. Connect the patch cord between the EQ IN jack and the 1000/+7/600 jack. Use a 21A TMS or an oscillator as a source of test power if no 1000/+7/600 jack is provided.
13	At the testboard, operate the SEND-RCV key to RCV. Observe the reading indicated by the measuring system meter. The difference between the indicated loss and the EML of the trunk is the change in loss required in the P _R pad. If a change is required, install an 89-type resistor in the pad which will provide a meter indication as close as possible to the EML (± 0.13 db). Pad changes, greater than 1 db from the computed value indicate that an investigation should be made for trouble in equipment components.
14	At the signaling bay, remove the zero loss connector and replace the SF signaling unit previously removed. Repeat the measurement made in Step 13. If the SF signaling unit is properly adjusted, the AML should equal the EML within ± 0.13 db.
15	At the vf patch bay, remove the patch cord and the 600-ohm terminations.
16	At the testboard, restore both trunks (outgoing and incoming) to service. Notify the distant office to restore the trunks to service. Disconnect test cords and restore keys to their normal positions.
17	Record the values determined for the P _T and P _R pads in ink on circuit layout cards and line out the computed values.
STEP	PROCEDURE
	<p data-bbox="212 1266 886 1293">Incoming Measurement and Adjustment of Office Losses</p> <p data-bbox="212 1325 1349 1482"><i>Note:</i> Before beginning the test, make sure that test power outlets have been checked, that the transmission and noise measuring system has been calibrated, and that assigned circuit equipment is in place. The P_T and P_R pads must be equipped with 89-type resistors when measurements are made. If no previous adjustment has been made, a computed value may be used.</p> <p data-bbox="94 1518 1349 1581">1 Make A and B patches shown in Fig. 1, connecting an outgoing trunk to the incoming trunk to be tested.</p> <p data-bbox="94 1612 1349 1675">2 At the testboard, connect a TST cord to the outgoing trunk TST jack and operate the associated TALK-MON key to TALK. Operate the SEIZE key.</p> <p data-bbox="94 1707 1349 1770">3 When the cord supervisory lamp is lighted, pulse forward code 101. When pulsing is completed, depress the ST key.</p> <p data-bbox="212 1801 1349 1864"><i>Note:</i> If the loop-around arrangement shown in Fig. 1 is not available, the incoming trunk must be seized from the distant office.</p>

STEP	PROCEDURE
4	Answer the incoming call using the CONN cord of a separate cord pair. Connect the CONN cord to the 101 trunk jack. Connect the associated TST cord to the MEAS jack. Operate the TST-101 key to the 101 position. The TALK-MON key, associated with the cord pair may be placed in the MON position.
5	Disconnect the TST cord used to seize the outgoing trunk.
6	At the vf patch bay, terminate the MOD IN and DEMOD OUT jacks of the carrier channel for the incoming trunk, using 600-ohm terminations. Terminate the trunk EQ IN jack, using a 600-ohm termination. Patch the EQ OUT jack to the TST 600 Ω jack, using a 2-conductor cord.
7	At the testboard, operate the SEND-RCV key to SEND.
8	Operate the B+10 sensitivity key and observe the reading indicated on the measuring system meter. The difference between the value indicated and -16 dbm (or other value specified for the office) is the change in loss of the P _T pad which must be made. If a change is required, replace the 89-type resistor with one which will bring the meter indication as close as possible to -16 dbm (± 0.13 db). If a change of more than 1 db from the computed loss for the P _T pad is necessary, investigation should be made for trouble in equipment components. <i>Note:</i> If a plug-in SF signaling unit is used in the trunk under test, replace the unit with a zero loss connector, see 2.04. If a permanently mounted SF signaling unit is used, see 2.03.
9	At the vf patch bay, disconnect the patch cord from the EQ OUT and TST 600 Ω jacks. Remove the termination from the EQ IN jack and insert it into the EQ OUT jack. Connect the patch cord between the EQ IN jack and the 1000/+7/600 jack. Use a 21A TMS or an oscillator as a source of test power if no 1000/+7/600 jack is provided.
10	At the testboard, operate the SEND-RCV key to RCV. Observe the reading indicated by the measuring system meter. The difference between the indicated loss and the EML of the trunk is the change in loss required in the P _R pad. If a change is required, install an 89-type resistor in the pad which will provide a meter indication as close as possible to the EML (± 0.13 db). Pad changes greater than 1 db from the computed value indicate that an investigation should be made for trouble in equipment components.
11	At the signaling bay, remove the zero loss connector and replace the SF signaling unit previously removed. Repeat the measurement made in Step 10. If the SF signaling unit is properly adjusted, the AML should equal the EML within ± 0.13 db.
12	At the vf patch bay, remove the patch cord and the 600-ohm terminations.
13	At the testboard, disconnect test cords and restore keys to their normal positions.
14	Record the values determined for the P _T and P _R pads in ink on circuit layout cards and line out the computed values.

B. Measurement and Adjustment of Office Losses in Station Lines (Equipped with E and M Leads)

2.11 The station line should be removed from service and terminated before beginning

the test. The customer should be notified that the line is being removed from service. The line should be made busy to the machine.

STEP	PROCEDURE
	<p>Measurement and Adjustment of Office Losses in Station Lines (Equipped with E and M Leads)</p> <p><i>Note:</i> Before beginning the test, check test power outputs, check calibration of the transmission and noise measuring system, and check that assigned circuit equipment is in place. The P_T and P_R pads must be equipped with 89-type resistors when measurements are made. If no previous adjustment has been made, a computed value may be used.</p> <p>1 At the testboard, connect a TST cord to the station line test jack. The test jack may be a DM or an LP TST jack.</p> <p>2 Connect the associated CONN cord to the SUB-MEAS jack. The TST-101 key should remain in the normal position. The TALK-MON key associated with the test cords being used should be placed in the normal or MON position.</p> <p>3 At the vf patch bay, insert a 600-ohm termination into the EQ IN jack, of the station line. Using a 2-conductor patch cord, connect the EQ OUT jack of the same line to the TST 600Ω jack.</p> <p>4 At the testboard, operate the SEND-RCV key to SEND.</p> <p>5 Operate the B+10 sensitivity key and observe the reading indicated by the measuring system meter. The difference between the value indicated and -16 dbm (or other value specified for the office) is the change in the loss of the P_T pad which must be made. If a change is required, replace the 89-type resistor with one which will bring the meter indication as close as possible to -16 dbm (± 0.13 db). Pad changes greater than 1 db from the computed value indicate that an investigation should be made for trouble in equipment components.</p> <p>6 At the vf patch bay, remove the cord from the EQ OUT and TST 600Ω jacks. Remove the 600-ohm termination from the EQ IN jack and insert it into the EQ OUT jack. Using the patch cord, connect the EQ IN jack to the 1000/+7/600 (or OSC OUT) jack.</p> <p>7 If a plug-in SF signaling unit is used, remove the unit and replace it with a zero-loss connector, see 2.04. If a permanently mounted SF unit is used, see 2.03.</p> <p>8 At the testboard, operate the SEND-RCV key to RCV. Observe the reading indicated by the measuring system meter. The difference between the indicated loss and the EML to the line link frame is the change in loss required in the P_R pad. If a change is required, replace the 89-type resistor, with a value which will provide a meter indication as close as possible to the EML (± 0.13 db). Pad changes greater than 1 db from the computed value indicate that an investigation should be made for trouble in equipment components.</p>

STEP	PROCEDURE
9	At the signaling bay, remove the zero loss connector and replace the SF signaling unit previously removed. Repeat the measurement made in Step 8. If the signaling unit is properly adjusted, the AML should equal the EML within ± 0.13 db.
10	At the vf patch bay, remove the patch cord and the 600-ohm terminations.
11	At the testboard, remove the busy condition from the station line. Advise the customer that the line is restored to service. Disconnect test cords and restore keys to their normal positions.
12	Record adjusted P_T and P_R pad values in ink on circuit layout cards and line out the computed values.

3. RELATIVE ENVELOPE DELAY AND FREQUENCY RESPONSE MEASUREMENTS

3.01 Trunks and lines carrying data must meet strict requirements for envelope delay and frequency response in addition to transmission loss requirements. When measurements of envelope delay and frequency response are made on a trunk between testboards in two offices, the office wiring and testboard circuits in each office contribute to the measured distortion. Since measurements may originate in either office, both the outgoing and incoming circuits in each office are involved. Reference measurements are required in each office to determine what amount of distortion will be contributed from these sources. Interoffice requirements apply to the circuit between the switches. Measurements are made at the equalizer bays in the two offices which approximate the locations of the link frames. The reference measurements described in this section apply to the end segments. See Fig. 2.

3.02 In order to make measurements as accurately as possible, one-way measurements are made rather than loop measurements. This type of measurement requires a gain and delay measuring set at each end of the segment being tested. A rack-mounted set is available at the testboard. A portable set must be provided at the equalizer bay.

3.03 A voice frequency circuit separate from the test circuit must be available between the

testboard and the equalizer bay. The second circuit need not have the same characteristics as the tested circuit. Only an acceptable transmission loss is required. Typical arrangements for outgoing and incoming reference measurements are shown in Fig. 2.

3.04 The loop-around arrangement shown in Fig. 1, if available, may be used to condition the outgoing trunks and to seize incoming trunks. If this arrangement is not available, the incoming trunk to be tested must be seized from the distant office.

3.05 Relative envelope delay measurements and frequency response measurements may be made during the same test procedure. Delay measurements are made at the transmitting end while frequency response measurements are made at the receiving end. Measurements of delay are referenced to 1000 cps.

Calibration of the 25A Voiceband Gain and Delay Measuring Set

3.06 Refer to Section 103-115-100 for the calibration procedure for the 25A set. Power should be applied for about 20 minutes before performing the calibration procedure. If power is removed from the sets for an hour or longer, the calibration procedure should be repeated when the sets are used again. Also, if the sets are in continuous use for longer than an hour, the calibration procedure should be repeated at approximately one-hour intervals.

STEP	PROCEDURE
1	<p>Measurement of Relative Envelope Delay and Frequency Response</p> <p>Remove the circuit from service, if required. If a 2-way trunk is being tested, the trunk should be removed from service at each end. If a station line is being tested, notify the customer that the line is out of service and make the line busy to the machine. Open the E and M leads at the SIG L/D jacks in the circuit patch bay. Terminate the MOD IN and DEMOD OUT jacks of the carrier channels at the vf patch bay.</p> <p><i>Note:</i> Calibration of the 25A sets should be completed before proceeding.</p> <p>Testing Toward the Equalizer Bay</p>
2	<p>At the testboard, operate 25A set controls as follows:</p> <p>OFF-NORMAL-REP switch to NORMAL</p> <p>TRANS OUTPUT-dbm switch to 0</p> <p>Line switch to LINE A</p> <p>DIAL-MEAS switch to 600</p>
3	<p>Connect a 25A LINE A jack to the upper (XMT) jack of the double 25A IN jack (SD-95900-01 measuring system) using a 2-conductor patch cord.</p>
4	<p>Connect a 25A LINE B jack to the upper (RCV) jack of the double jack of a 2-way test trunk between the testboard and the equalizer bay. Use a 2-conductor patch cord.</p>
5	<p>At the equalizer bay, operate 25A set controls as follows:</p> <p>OFF-NORMAL-REP switch to REP</p> <p>TRANS OUTPUT-dbm switch to 0</p> <p>Line switch to LINE A</p> <p>DIAL-MEAS switch to 600</p> <p>FREQUENCY to REF</p>
6	<p>Connect a 25A LINE A jack to the lower (XMT) jack of the double jack of the test trunk between the equalizer bay and the testboard. Use a 2-conductor cord.</p>
7	<p>Connect a 25A LINE B jack to the EQ OUT jack of the circuit under test. Use a 2-conductor patch cord.</p>

STEP	PROCEDURE
8	<p>Referring to Fig. 2, connect the testboard test cords as follows:</p> <p>(a) Outgoing test at a network trunk TST jack or at a station line TST, LP TST, or LOOP jack</p> <p>If not already required in removing the circuit from service, connect a TST cord to the trunk or line test jack. Connect the associated CONN cord to the TST MEAS jack (network trunk test) or to the SUB MEAS jack (station line test). If a network trunk test is being made, operate the TST-101 key to TST. If a station line test is being made, leave the TST-101 key in the normal position.</p> <p>(b) Incoming test via a 101 test trunk</p> <p>A CONN cord has been connected to the 101 trunk jack to answer the incoming call. Connect the associated TST cord to the 101 MEAS jack. Operate the TST-101 key to 101.</p>
9	Place the test cord TALK-MON key in the normal position during measurements.
10	At the testboard 25A set, adjust the FREQUENCY control to obtain an output of 1000 cps, as indicated on the frequency meter.
11	<p>At the testboard 25A set, obtain a reference zero at 1000 cps as follows:</p> <p>(1) Adjust the delay reading to 0, as nearly as possible, using the ADD MICROSECONDS switch.</p> <p>(2) Adjust the delay reading exactly to 0, using the DELAY ZERO control.</p> <p>(3) Pull out the ADD MICROSECONDS knob and set the pointer to 0. Without moving the pointer, push in the knob.</p>
12	At the testboard 25A set, adjust the level control to an on-scale reading on the RCVD LEVEL-dbm meter. The level indicated is that of the carrier, returned from the far-end 25A set, and is not significant to the tests except that the level should not change during the tests.
13	At the equalizer bay 25A set, adjust the level control to obtain an on-scale reading on the RCVD LEVEL-dbm meter. The level indicated is that of the 1000-cycle carrier from the near-end 25A set. Record the indicated level for reference purposes.
14	<p>At the testboard 25A set, set the FREQUENCY control to obtain outputs at 100-cycle intervals from 300 to 3200 cps, reading and recording the results as follows:</p> <p>(1) At the testboard 25A set, read and record <i>delay</i> (relative to 1000 cps) at frequency settings from 500 to 3200 cps.</p> <p>(2) At the equalizer bay 25A set, read and record the <i>gain/loss</i> (relative to 1000-cps reference obtained in Step 13) at frequency settings from 300 to 3000 cps.</p>

STEP	PROCEDURE
	<p><i>Testing Toward the Testboard</i></p> <p>15 At the testboard 25A set, operate the OFF-NORMAL-REP switch to REP. Operate the line switch to LINE B.</p> <p>16 At the equalizer bay 25A set, operate the OFF-NORMAL-REP switch to NORMAL. Operate the line switch to LINE B.</p> <p>17 Dotted-line connections are shown in Fig. 2 at each end of the test trunk, at the 25A IN jack, and at the equalizer bay EQ jacks. Make these connections instead of the indicated solid-line connections.</p> <p>18 Repeat the procedure, performing operations at the equalizer bay 25A set which were performed at the testboard 25A set and performing operations at the testboard 25A set which were performed at the equalizer bay 25A set. Record results in the same manner.</p> <p>19 Disconnect test sets and cords. Restore all testboard keys to their normal positions. Restore the trunk or line to service.</p> <p>Note: The recorded relative envelope delay and amplitude distortion measurements should be kept for reference purposes. When overall measurements are made between testboards, these reference measurements will be used to indicate what part of the measured distortion is contributed by the office wiring and testboard circuits.</p>

4. PRECUTOVER SIGNALING AND SUPERVISION TESTS

- 4.01 The trunk loop-around arrangement shown in Fig. 1 may be used for testing the signaling and supervision capabilities of trunk equipment on a precutover basis.

STEP	PROCEDURE
1	<p>With loop-around connections made as shown in Fig. 1, connect a TST cord to the trunk TST jack. Operate the TALK-MON key to TALK. Operate the SEIZE key. Connect a CONN cord to the incoming 101 trunk.</p>
2	<p>Perform supervisory and signaling tests described in Section E26.001.04.</p> <p>Note: At the circuit patch bay, for testboards provided with neon lamp signaling test circuits, the SIG T cord may be connected to the SIG L/D jacks of the outgoing trunk for monitoring the signaling tests.</p>
3	<p>Remove A and B patches connected to the trunk equipment. Disconnect cords and restore keys to their normal positions.</p>

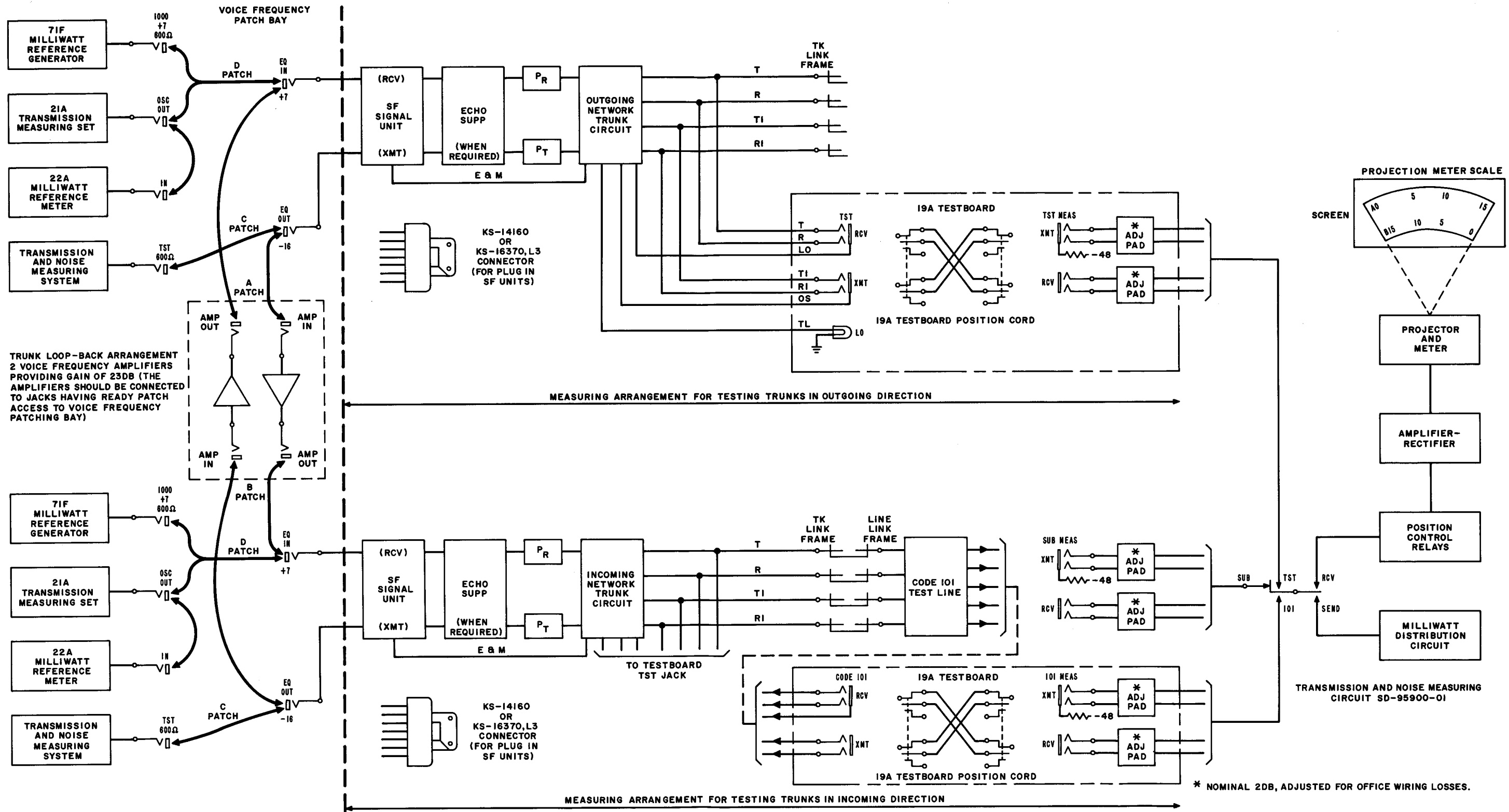

Fig. 1 — Measurement and Adjustment of Transmission Levels

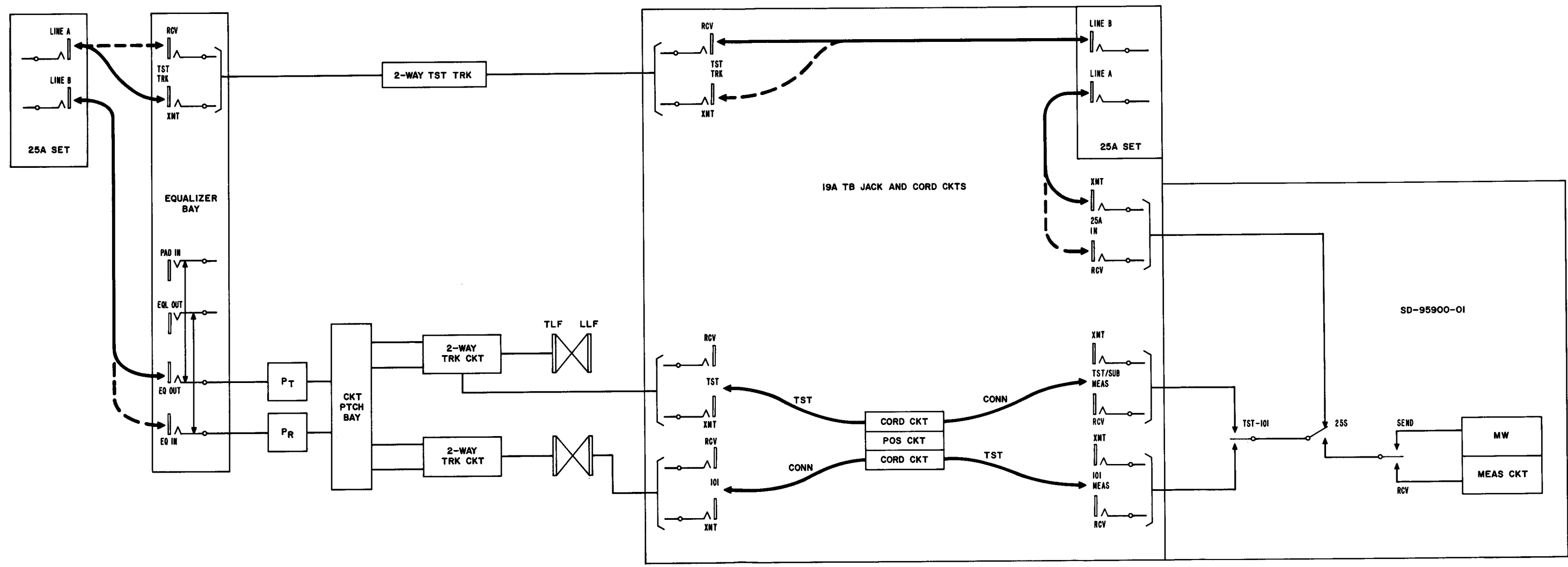
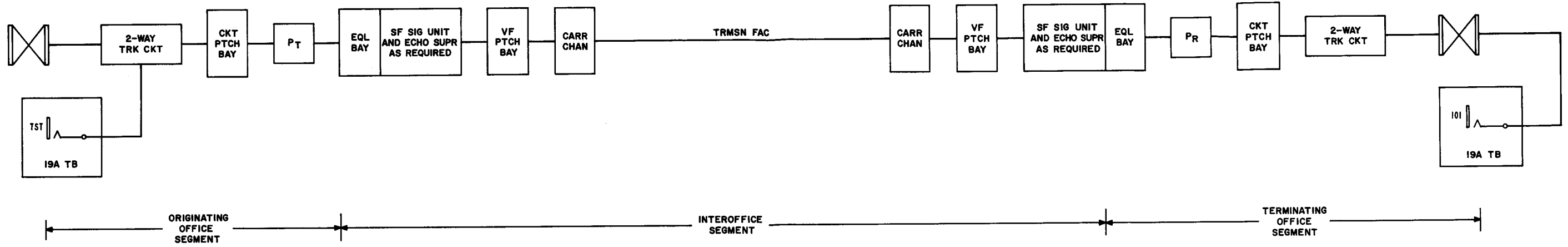

Fig. 2 — Typical Arrangement for Making Reference Measurements of Relative Envelope Delay and Frequency Response