

**PRIVATE LINE TELEPHONE SYSTEMS AND SERVICES**  
**BALANCE TEST PROCEDURES FOR PBX**  
**SWITCHED 4-WIRE TIE TRUNKS**  
**AND ACCESS LINES**

CONTENTS	PAGE
1. GENERAL . . . . .	1
2. TEST EQUIPMENT . . . . .	2
3. ESTABLISHING CONNECTION TO TEST TIE TRUNK . . . . .	3
4. NET LOSS MEASUREMENT OF BALANCE PATH . . . . .	4
5. THROUGH AND TERMINAL BALANCE TESTS . . . . .	6
6. NETWORK BUILDING-OUT CAPACITOR ADJUSTMENT TESTS . . . . .	7
7. THROUGH BALANCE — ECHO RETURN LOSS TESTS . . . . .	9
8. THROUGH BALANCE — SINGING POINT TESTS . . . . .	11
9. TERMINAL BALANCE — ECHO RETURN LOSS TESTS . . . . .	13
10. TERMINAL BALANCE — SINGING POINT TESTS . . . . .	15

**1. GENERAL**

**1.01** This section describes detailed procedures for making through and terminal balance tests at 2-wire PBXs. The section is being re-issued to give more detailed information for balance tests and to delete material now covered in other sections. Due to extensive changes, marginal arrows are omitted.

**1.02** Information pertaining to the theoretical aspects of balance testing and objectives is given in Section 310-350-100. An understand-

ing of this theoretical material will be of considerable assistance to the testman making the balance tests covered in this section. These tests are required *at PBXs* under the following conditions:

(a) **THROUGH BALANCE** tests are required at each PBX where 4-wire VNL tie trunks can be connected together at VNL, that is, with the 2 db pads switched *out*. (See Section 310-350-100, Par. 4.01.)

(b) **TERMINAL BALANCE** tests are required at each PBX on all non-VNL facilities that can be connected to 4-wire VNL tie trunks. (Section 310-350-100, Par. 5.01.)

*Note:* Switched Services Network 4-wire VNL access lines are to be considered the same as 4-wire VNL tie trunks.

**1.03** Balance test procedures consist of the following basic tests:

(1) **NETWORK BUILDING-OUT CAPACITOR (NBOC) ADJUSTMENT TESTS.** These tests are made to determine the value of capacitance that is to be provided in the compromise balancing network of all 4-wire terminating sets at the PBX. This capacitance is approximately equal to the shunt capacitance of the PBX equipment and wiring involved when the 2-wire sides of 4-wire terminating sets are connected together via the PBX switching machine or switchboard.

(2) **ECHO RETURN LOSS (ERL) TEST.** This test determines the return loss in the echo range (500 to 2500 cycles). The objectives given in TABLE B must be met to provide adequate echo performance. This test is used in both **THROUGH** and **TERMINAL** balance procedures.

(3) SINGING POINT (SP) TESTS. These tests determine the balance margin against singing conditions. The lowest degree of balance generally occurs in the frequency ranges of 200 to 500 or 2500 to 3200 cycles. Inadequate balance in these frequency ranges may result in singing or a near singing condition commonly recognized as the "rain-barrel" effect.

1.04 Test equipment arrangements required for the various test procedures are illustrated in Fig. 1 to 8.

1.05 The test procedures given in this section are based on the use of the 24V4 repeater equipment with 1-type 4-wire terminating sets and either SD-65718-01 or SD-66799-01 tie trunk equipment. Where other equipment is used the general procedures outlined are still valid, although some of the detailed steps and test equipment arrangements may have to be adjusted to conform to the equipment used.

1.06 The balance tests involve working with two trunk circuits switched together by the PBX switching machine or the switchboard. To avoid confusion in the test procedures, the tie trunk being balanced is referred to as the *test tie trunk*. The tie trunk or other service line used in the test will be identified as the "*connected trunk*" or "*connected circuit*," as appropriate.

1.07 Where a station set "off hook" is required for a balance termination, the handset transmitter and receiver should be effectively muffled to prevent room noise from overriding the balance test power. The handset may be wrapped in a sound-deadening material to provide this muffling. The transmitter unit must not be removed from the handset as a room noise deterrent because this would alter the impedance of the telephone set and give erroneous test results.

1.08 The tests require that the normal transmission path be established between the test tie trunk and connected circuit via the PBX switches or switchboard. For TERMINAL balance tests, the transmission path must be established from the 4-wire legs of the test tie trunk through the PBX to the distant termination of the connected circuit. Assistance will be re-

quired at the far end to remove and muffle a telephone handset, to provide the off-hook termination when specified.

1.09 *Important! Make sure all test equipment is accurately calibrated and functioning properly*, in accordance with current instructions.

1.10 Forms on which measurement results can be recorded as they are made are recommended. Such completed forms can be used as a worksheet during tests, and provide a permanent record for future reference in connection with possible trouble tests or the installation of additional tie trunks. Typical forms are shown in Charts A and B, which cover the following tests:

Chart A. Measurement Record and Worksheet Network Building-Out Capacitance Tests.

Chart B. Measurement Record and Worksheet Echo Return Loss and Singing Point Tests.

## 2. TEST EQUIPMENT

2.01 The following major items of test equipment will be required to perform the tests outlined in this section. If it is desired to substitute any measuring sets for those listed, the suitability of the substitution should be verified with the appropriate transmission group.

(a) Network Building-Out Capacitor (NBOC) Tests.

(1) 21A Transmission Measuring Set (TMS).

or

(2) TTS-4A (Northeast Electronics) Transmission Measuring Set.

or

(3) KS-19353 Oscillator and 23A Transmission Measuring Set.

(4) Decade Capacitor, 7A or General Radio 1419A.

(b) Echo Return Loss Tests.

(1) 201A or B Noise Generator with 455B weighting network and 3A Noise Measuring Set with C message weighting (497A) network.

## (c) Singing Point Test.

- (1) 2D Singing Point Test Set, 207G Filter, and 52-type headset.

## (d) Miscellaneous Equipment.

- (1) Normal test items, such as volt-ohm-meters, dial handsets, etc.
- (2) Appropriate test cords, test clips, and connectors for all test equipment.
- (3) Shorting plugs, 600-ohm termination plugs, dummy plugs.

**2.02** *It is essential that all test equipment be accurately calibrated before any tests are attempted;* an inaccurate calibration will result in false readings which may lead to misalignment of facilities and poor service. Details on the operation and calibration of each instrument are covered in the appropriate Bell System Practices. Adequate warmup time should be allowed for the measuring sets to stabilize before starting the adjustment procedures.

**2.03** The following is a list of the BSPs for each of the measuring sets mentioned in Par. 2.01.

- 21A TMS — BSP 103-221-100
- TTS-4A TMS — BSP 103-204-100
- KS-19353 OSC — BSP 103-302-105
- 23A TMS — BSP 103-223-100
- 201 A or B Noise Gen. — BSP 103-345-100
- 3A NMS — BSP 103-611-100
- 2D Singing Point T.S. — BSP 103-106-105

### 3. ESTABLISHING CONNECTION TO TEST TIE TRUNK

**3.01** To make the prescribed balance tests, the selected test tie trunk must be connected to the trunk or line that it is to be balanced against. Where normal PBX operation provides for switching the tie trunks to other trunks and lines via the SxS switches and the switchboard, balance tests should be made over each of the connection paths, in accordance with the considerations given in Section 310-350-100.

## (A) Connection via Switches

**3.02** The following procedures apply in establishing the connection via the SxS switches between the selected test tie trunk and any other service line that balance tests are to be made to.

- (1) Connect a 1011A test set between the test tie trunk circuit B1 lead and any convenient ground. The B1 lead appears on the top lug of the D jack, or on pin 3 of the trunk "B" terminal strip.

- (2) If connection is being established for THROUGH balance or NBOC test:

- (a) Dial appropriate code to connect to desired 4-wire tie trunk.

- (b) When connection is established, block the "R" relay of the connected trunk circuit to give "off-hook" supervision. This can be done by inserting a flat toothpick or appropriate tool between the right pole piece and armature of the "R" relay.

- (c) Block the "R" relay of the test trunk circuit in the same manner as in (b) above.

- (d) Remove test set from B1 lead and proceed with tests outlined in Parts 6, 7, and 8.

- (3) If connection is being established for TERMINAL balance to station line:

- (a) Dial appropriate code for switching to desired station or balance test line, if provided.

- (b) Have station come off hook and remain off hook for remainder of test. Muffle station transmitter per Par. 1.07.

- (c) Block the "R" relay of the test trunk circuit, as described in 2(b).

- (d) Remove test set from B1 lead and proceed with tests outlined in Parts 6, 9, and 10.

- (4) If connection is being established for TERMINAL balance test to C.O. or foreign exchange trunk:

- (a) Dial appropriate code for connection to desired trunk. Then dial code to terminate the trunk in the central office Balance Test Termination (900-ohm and 2 mfd).

## SECTION 310-350-500

- (b) Block "R" relay of test trunk circuit, as described in 2(b).
  - (c) Remove test set from B1 lead and proceed with tests, as outlined in Parts 6, 9, and 10.
- (5) If connection is being established for TERMINAL balance to a tie trunk:
- (a) If the far-end PBX (on the connected tie trunk) is equipped with a 900-ohm test termination, dial the appropriate code to establish connection to this test termination. Skip steps (b) and (c) below. This is the preferred method.
  - (b) If there is no test termination to dial into at the far-end PBX, dial the appropriate codes to terminate to an "on premise" station (close to the equipment room) at the far-end PBX.
  - (c) Have station come off hook and remain off hook for remainder of test. Muffle station transmitter per Par. 1.07.
  - (d) Block "R" relay of test trunk circuit, as described in 2(b).
  - (e) Remove test set from B1 lead and proceed with tests, as outlined in Parts 6, 9 and 10.

### (B) Connection via Switchboard

**3.03** Procedures for establishing connection via a switchboard cord pair are similar to those given in Par. 3.02. Follow these procedures, with the following variations:

- (a) Dial the appropriate code to reach the switchboard attendant.
- (b) Request the PBX attendant to put up the desired connection and dial up the appropriate termination on the connected circuit. The key associated with the cord pair used must be closed after connection is established.
- (c) For NBOC and THROUGH balance tests, have PBX attendant use "thru" jack appearance of both tie trunks.
- (d) For TERMINAL balance tests to C.O., foreign exchange, and other tie trunks, the "thru" jack appearance of the test tie trunk is used.
- (e) For TERMINAL balance tests to station lines, the "Talk" or "Ans" jack of the test tie trunk is used.

## 4. NET LOSS MEASUREMENT OF BALANCE PATH

**4.01** To meet balance objectives, the connection path between the test tie trunk and the connected circuit must be trouble-free, and in the case of THROUGH balance tests the switched pads must be operated to the "out" position. The proper operation of the connection path for both THROUGH and TERMINAL balance may be verified by a net loss measurement at 1000 cycles between the test tie trunk and the connected trunk or circuit. Also, all trunks or circuits to which TERMINAL balance tests are made must be operating at the proper loss.

**4.02** It is not considered necessary to make a net loss check of every balance connection established. A net loss measurement should be made in conjunction with the first connection established to each type circuit group, i.e., 4-wire tie trunks, 2-wire tie trunks, station lines, C.O. trunks, etc. If a balance measurement to any particular circuit within a group varies markedly from the others within that group, a net loss check of the balance path should be made.

**4.03** Test equipment and circuit arrangements for such a check measurement between the test tie trunk and any connected circuit are shown in Fig. 1. A net loss measurement not in excess of  $\pm 0.5$  db from the computed value or value on the circuit layout record card is satisfactory. Table A gives the values of equipment losses that may be required to compute the loss of the path through the office.

**TABLE A**

### PBX Balance Path 1000-Cycle Losses

1A Term. Unit, 3.7 db —	PBX SXS Path, .3 db
1C Term. Unit, 3.9 db —	PBX Swb Path, .8 db
	2-Wire Tie Trunk .3 db
	Circuit
2 db Switched	4-Wire Tie Trunk, 0 db
Pad "IN", 2.0 db —	Circuit
	(SD-65718-01,
	Issue 13 or
	SD-66799-01)

**4.04** Since there is generally no suitable jack access point on 2-wire circuits, verification of the balance path will require opening the 2-wire circuit at some point between its trunk circuit and the cable pair, and terminating

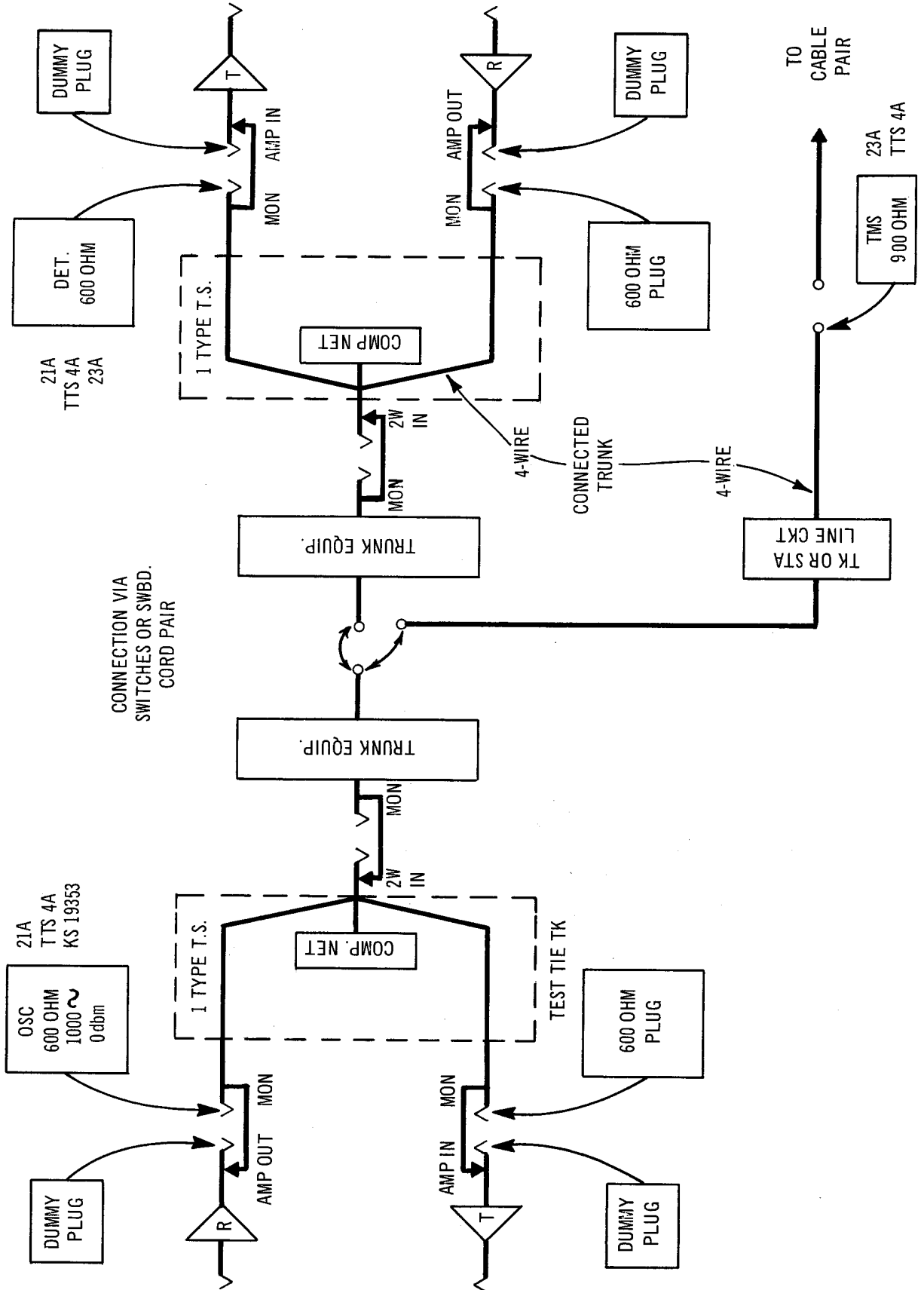

Fig. 1 -- Test Arrangement for Checking Transmission Loss of Balance Path

## SECTION 310-350-500

it in a 23A TMS. It will be necessary to place a short across the circuit, between the PBX equipment and the measuring point, to hold the connection up during the process of opening it and connecting the TMS. Once the TMS is connected, it will hold up the connection and the short must be removed.

### 5. THROUGH AND TERMINAL BALANCE TESTS

#### (A) Through Balance Tests

**5.01** THROUGH balance tests (Section 310-350-100, Par. 4) consist of the following individual test procedures:

(1) NBOC ADJUSTMENT TESTS. Circuit and test equipment arrangements are shown in Fig. 2. Test procedures are given in Part 6. These tests, unless omitted (Par. 5.03 to 5.05), must be completed prior to starting ERL or SP tests.

(2) ERL TEST. Circuit and test equipment arrangements are shown in Fig. 3. Test procedures are given in Part 7.

(3) SP TESTS. Circuit and test equipment arrangements are shown in Figs. 4 and 5. Test procedures are given in Part 8.

**5.02** The ERL and SP tests may be made in any sequence convenient to the tester.

**5.03** The NBOC test may be dispensed with where the NBOC value has been previously established on existing tie trunk groups, and where the equipment location of the tie trunk(s) being added is such that the switching path on the new tie trunk(s) will be approximately the same (lengthwise) as on the existing tie trunks. In this case, the NBOC of the

new trunk(s) would be adjusted to the previously established value without additional testing.

**5.04** Situations may arise where the equipment for a new trunk(s) is located at some distance from the existing tie trunk equipment. If this cannot be avoided, it may be necessary to determine a new average NBOC value for *all* the tie trunks and to make new ERL and SP tests.

**5.05** If there is any question regarding the need for NBOC tests in connection with the installation of a new tie trunk(s), the matter should be referred to the appropriate design or transmission group for consideration.

#### (B) Terminal Balance Tests

**5.06** TERMINAL balance tests (Section 310-350-100, Par. 5) are made after completion of the THROUGH balance testing and consist of the following test procedures:

(1) ERL TEST. Circuit and test equipment arrangements are shown in Fig. 6. Test procedures are given in Part 9.

(2) SP TEST. Circuit and test equipment arrangements are shown in Figs. 7 and 8. Test procedures are given in Part 10.

**5.07** The above tests may be made in any sequence convenient to the tester.

**5.08** At PBX locations where THROUGH balance tests are not required but TERMINAL balance tests are required, the NBOC tests may be required. (Section 310-350-100, Par. 5.03-5.04.)

## 6. NETWORK BUILDING-OUT CAPACITOR (NBOC) ADJUSTMENT TESTS

6.01 Test equipment arrangements are shown in Fig. 2. The figure, together with the following step-by-step procedures comprise the necessary testing to determine an NBOC value for PBX 4-wire tie trunks.

- Step 1 — Establish connection between the selected test tie trunk and the connected trunk via the PBX switches. If tie trunks to be tested are "manual only," establish connection via switchboard. Instructions for establishing either connection are contained in Part 3.
- Step 2 — All screws on the front of the type-1 terminating units must be in their normal operating condition except the NBOCs. The NBOC screws must be open (screw loosened).
- Step 3 — Adjust the oscillator section of the TMS for 0 dbm output at 2000 cycles. The oscillator is to remain on this adjustment for the remainder of these tests.
- Step 4 — Connect test equipment and terminate the connected circuit in accordance with Fig. 2. Adjust the detector attenuator of the TMS to give a reading on the meter.

**Note:** The 24V4 repeaters are terminated (386A plugs) at the jacks on the 4-wire line side of the amplifiers so that the correct impedance will appear at the terminating set. Other types of 4W term. sets may be terminated at the 4-wire legs of the hybrid coil.

- Step 5 — A capacitor decade box or the NBOC screw switches may be used for adjusting NBO capacitance in Step 6. If the decade box is to be used, connect it now in accordance with Fig. 2. Starting from zero, the capacitance is increased in minimum steps (.002 mfd for the 1-type 4WTS, .001 mfd for decade box) by means of the decade box dials or the appropriate combination of NBOC screws on the 4WTS.
- Step 6 — Increase NBO capacitance in minimum steps, and adjust the detector attenuator as necessary, to obtain the minimum return power (highest numerical-negative) reading on the TMS meter. Record the measured loss (Col. A or C, Chart A) and the adjusted capacitance of the decade box or NBOC screws (Col. B or D, Chart A).
- Step 7 — Repeat above test procedure on all trunks selected for the NBOC adjustment tests per Section 310-350-100, Par. 4.06. Where both dial and switchboard switching of these tie trunks is provided for, the NBOC test procedures above should be made over both paths.
- Step 8 — Determine in accordance with Section 310-350-100, Par. 4.07, the average capacitance value for the PBX and adjust all NBOCs in all 4-wire tie trunks to this value.

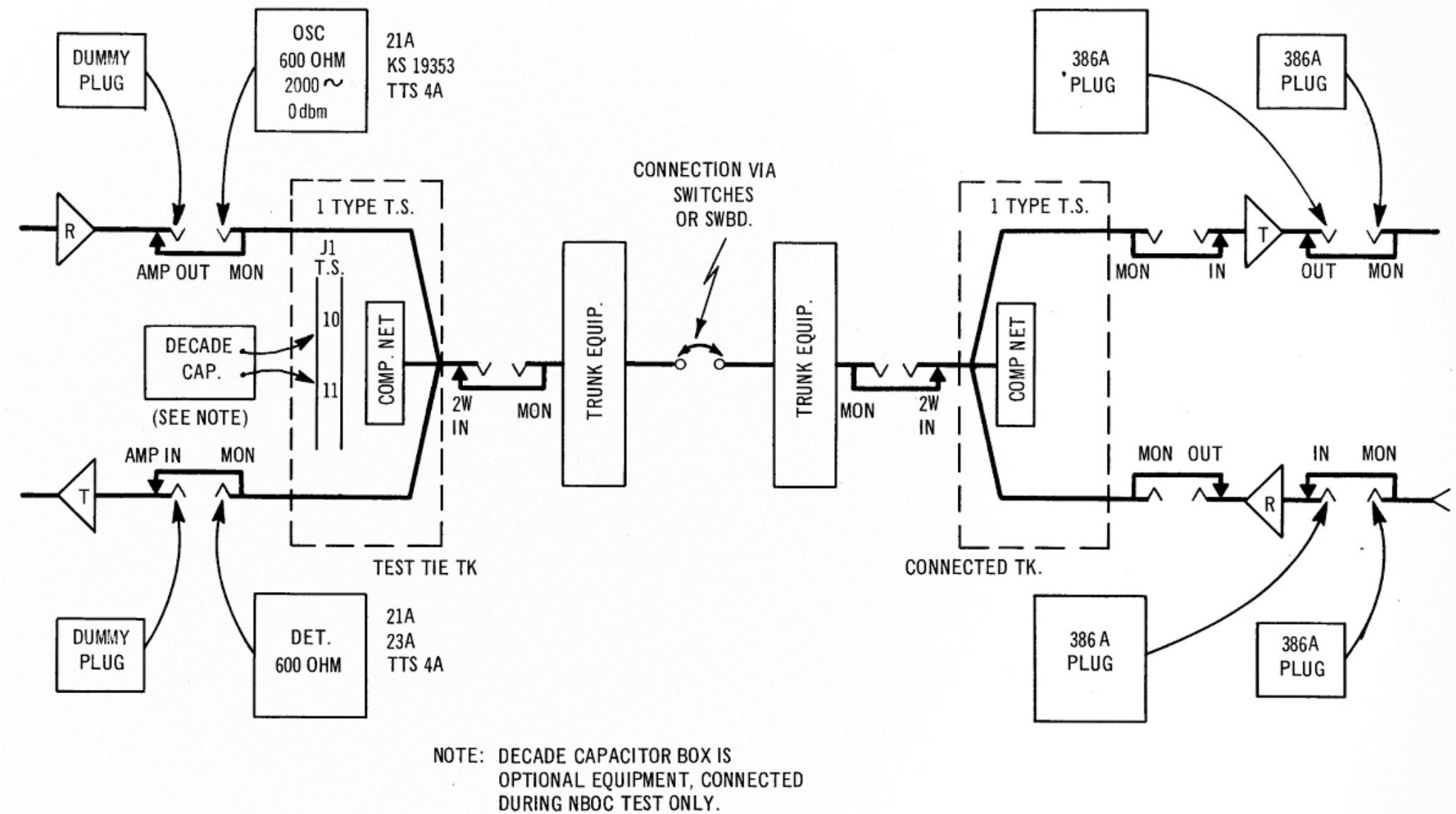

Fig. 2 — Through Balance Tests — Network Building-Out Capacitor Adjustment

## 7. THROUGH BALANCE — ECHO RETURN LOSS TESTS

7.01 Test equipment arrangements are shown in Fig. 3 for THROUGH balance. The figure together with the following step-by-step procedures comprise the necessary testing to determine that the tie trunks meet the THROUGH balance echo return loss requirements.

Step 1 — Establish connection between the selected test tie trunks and the connected circuit via the PBX switches. If tie trunks to be balanced are "manual only," establish connection via switchboard. Instructions for establishing either connection for THROUGH balance are contained in Part 3.

Step 2 — All screws on the front of the 1-type 4-wire term. set must be in the position specified on the circuit order card and the NBOC screws in the position determined in Part 6.

Step 3 — Connect test equipment and terminate the connected circuit in accordance with Fig. 3.

**Note:** The 24V4 repeaters are terminated (386A plugs) at the jacks on the 4-wire line side of the amplifiers so that the correct impedance will appear at the terminating set. Other types of 4-wire term. sets may be terminated at the 4-wire legs of the hybrid coils.

Step 4 — Adjust the 201B Noise Gen. for 0 dbm output. Adjust the attenuator of the 3A NMS to obtain a reading on the meter. Record the reading (Chart B, Col. A). Return attenuator to maximum step.

Step 5 — Insert the shorting plug into the 2-wire "MON" jack and block the "PO" relay to switch *out* the 2 db pad in the trunk equipment of the test tie tk. Adjust the attenuator of the 3A NMS to obtain a reading. Record the reading (Chart B, Col. B). Remove shorting plug and release the PO relay.

Step 6 — Subtract the reading obtained in Step 4 from that obtained in Step 5. The difference is the value of echo return loss for this connection. Record this reading in Col. C, Chart B.

Step 7 — Repeat the above test procedures for the remainder of the sample selected for testing per Section 310-350-100, Par. 4.06-4.11.

Step 8 — Compare the results of the Echo Return Loss tests with the objectives in Table B for THROUGH balance. If the objectives are not met, trouble investigations should be made in accordance with Section 310-350-100, Par. 6.02-7.02 and local instructions.

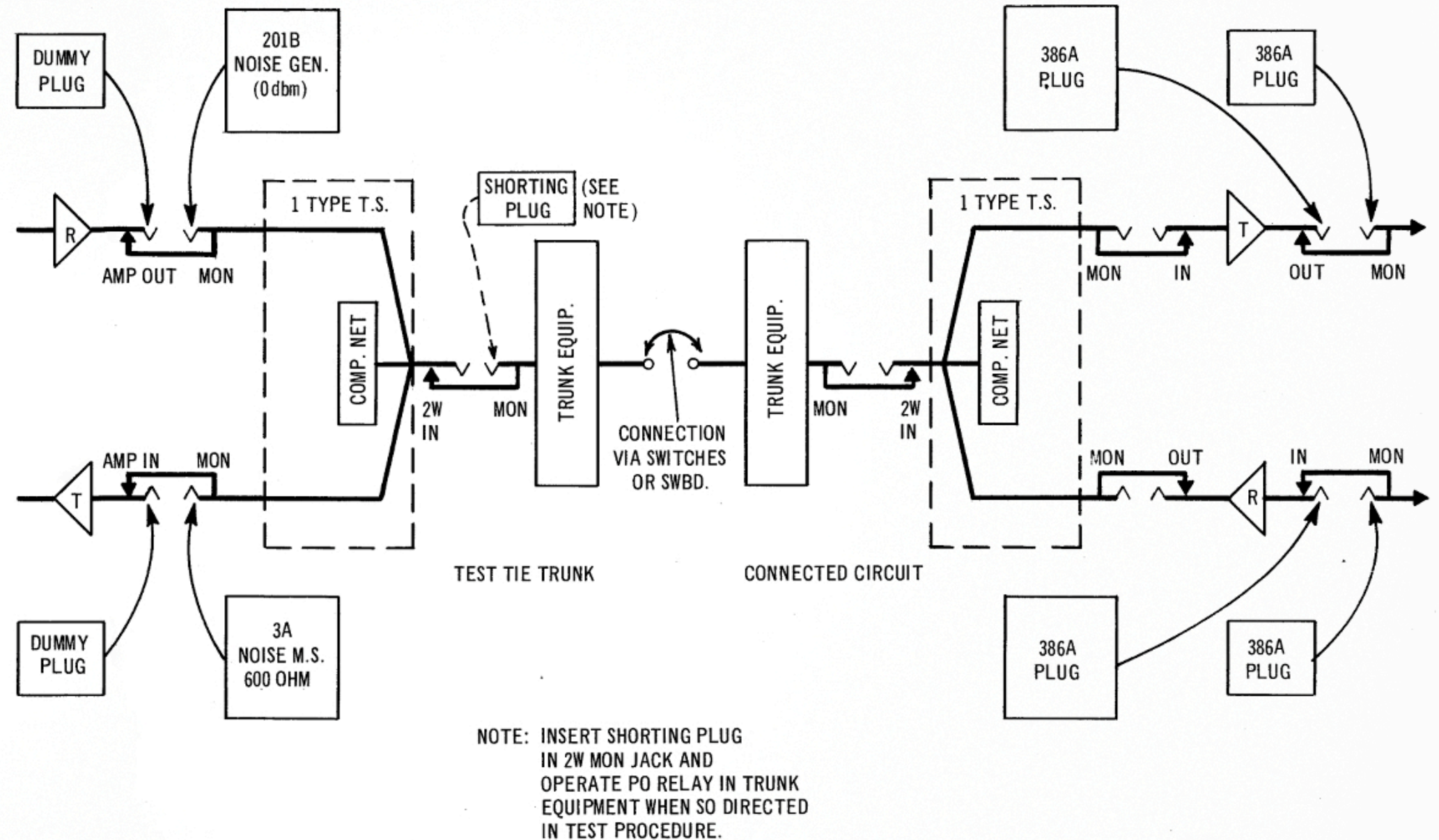

Fig. 3 — Through Balance Tests — Equipment Arrangement for Echo Return Loss Tests



**8. THROUGH BALANCE — SINGING POINT TESTS**

8.01 Test equipment arrangements are shown in Fig. 4 for THROUGH balance tests. The figure together with the following step-by-step procedures comprise the necessary testing to determine that the tie trunks meet the THROUGH balance singing point requirements.

Step 1 — Establish connection between selected test tie trunk and the connected circuit via the PBX switches. If tie trunks to be balanced are "manual only," establish connection via switchboard. Instructions for establishing either connection for THROUGH balance are contained in Part 3.

Step 2 — All screws on the front of the 1-type 4-wire term. set must be in the position specified on the circuit order card and the NBOC screws in the position determined in Part 6.

Step 3 — Connect test equipment and terminate the connected circuit in accordance with Fig. 4.

**Note:** The 24V4 repeaters are terminated (386A plugs) at the jacks on the 4-wire line side of the amplifiers so that the correct impedance will appear at the terminating set. Other types of 4-wire term. sets may be terminated at the 4-wire legs of the hybrid coils.

Step 4 — Plug 52-type headset into the "MON" jack of the 2D SPTS. Increase setting of 50 db gain attenuator clockwise until sustained singing is heard in the headset, then turn the attenuator back one step.

Step 5 — Increase the setting of the 10 db gain attenuator slowly until sustained singing is just heard in the headset. Note the sum of the two attenuator dials at the point where singing just begins.

Step 6 — Repeat Steps 4 and 5 with the poling key operated to reverse. A different value of attenuator settings will generally be obtained with the poling key reversed.

Step 7 — The lower sum of the attenuator dial settings from the preceding tests is the measured singing point in db. Record this value in Col. D of Chart B. Restore gain attenuators to 0.

Step 8 — Connect the equipment as shown in Fig. 5. Insert the shorting plug into the 2-wire "MON" jacks and block the "PO" relay to switch out the 2 db pad in the trunk equipment. Adjust the oscillator to send 1000 cycles at 0 dbm into the "IN" jack. Record the reading of the TMS detector in Col. E of Chart B. This is the singing point hybrid correction factor for the circuit under test. Remove the shorting plug and test equipment connectors and release "PO" relay.

Step 9 — Subtract the hybrid correction factor (Step 8) from the measured singing point (Step 7). The difference is the singing point for this connection, and is recorded in Col. F of Chart B.

Step 10 — Repeat the above procedures for the remainder of the sample selected for testing per Section 310-350-100, Par. 4.06-4.11.

Step 11 — Compare the singing points obtained by testing with the objectives in Table B, to determine if corrective measures are required.

**Note:** If the same test tie trunk is used for a series of tests, Step 8 is required only once to determine the hybrid correction factor for this series.

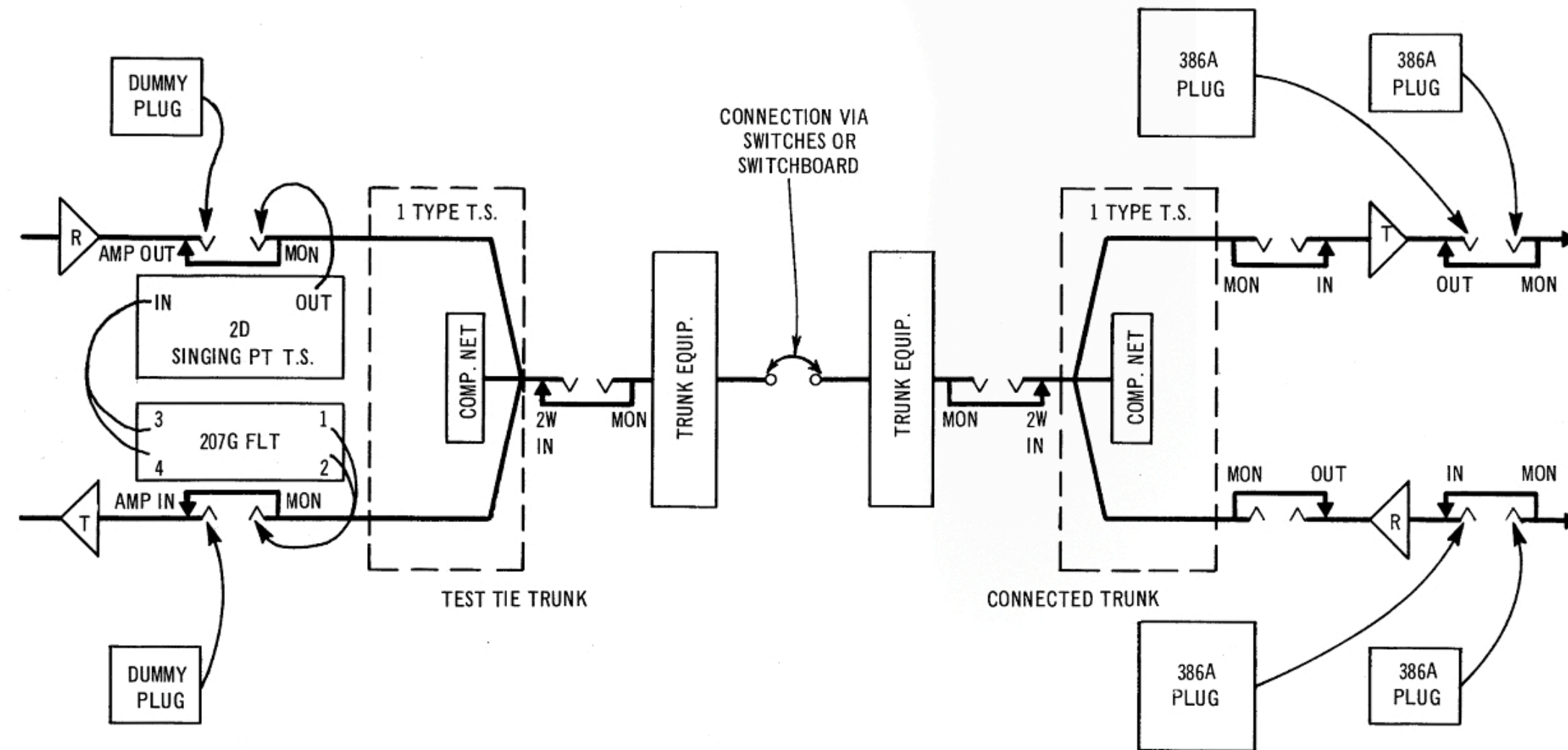

Fig. 4 - Through Balance Tests — Equipment Arrangement for Singing Point Measurement

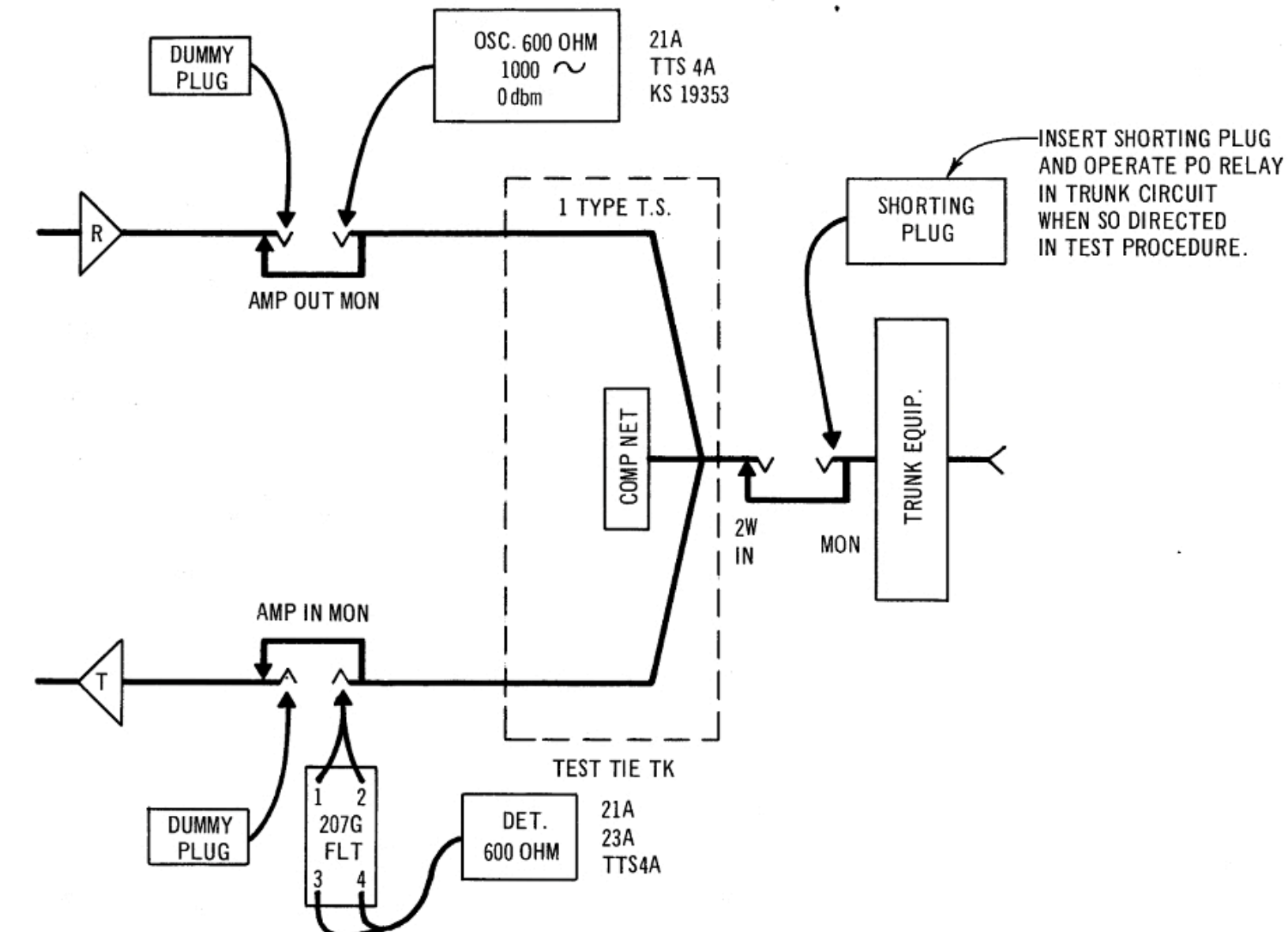

Fig. 5 - Singing Point Tests — Equipment Arrangement to Determine Hybrid Correction Factor

### 9. TERMINAL BALANCE — ECHO RETURN LOSS TESTS

9.01 Test equipment arrangements are shown in Fig. 6 for TERMINAL balance. The figure together with the following step-by-step procedures comprise the necessary testing to determine that the tie trunks meet the TERMINAL balance echo return loss requirements.

- Step 1 — Establish connection between the selected test tie trunk and the connected circuit via the PBX switches. If tie trunks to be balanced are "manual only," establish connection via switchboard. Instructions for establishing either connection for TERMINAL balance are contained in Part 3.
- Step 2 — All screws on the front of the 1-type 4-wire term. set must be in the position specified on the circuit order card and the NBOC screws in the position determined in Part 6.
- Step 3 — Connect the test equipment and terminate the connected circuit in accordance with Fig. 6.
- Step 4 — Adjust the 201B Noise Gen. for 0 dbm output. Adjust the attenuator of the 3A NMS to obtain a reading on the meter. Record the reading (Chart B, Col. A). Return attenuator to the maximum step.
- Step 5 — Insert the shorting plug into the 2-wire MON jack and block the PO relay to switch **Out** the 2 db pad in the trunk equipment of the test tie trunk. Adjust the attenuator of the 3A NMS to obtain a reading. Record the reading (Chart B, Col. B). Remove the shorting plug and release the PO relay.
- Step 6 — Subtract the reading obtained in Step 4 from that obtained in Step 5. The difference is the value of echo return loss for this connection. Record this reading in Col. C, Chart B.
- Step 7 — Repeat the above test procedures for the remainder of the sample selected for testing per Section 310-350-100, Par. 4.06-4.11.
- Step 8 — Compare the results of the Echo Return Loss tests with the objectives in Table B for TERMINAL balance. If the objectives are not met, trouble investigations should be made in accordance with Section 310-350-100, Par. 6.02-7.02 and local instructions.

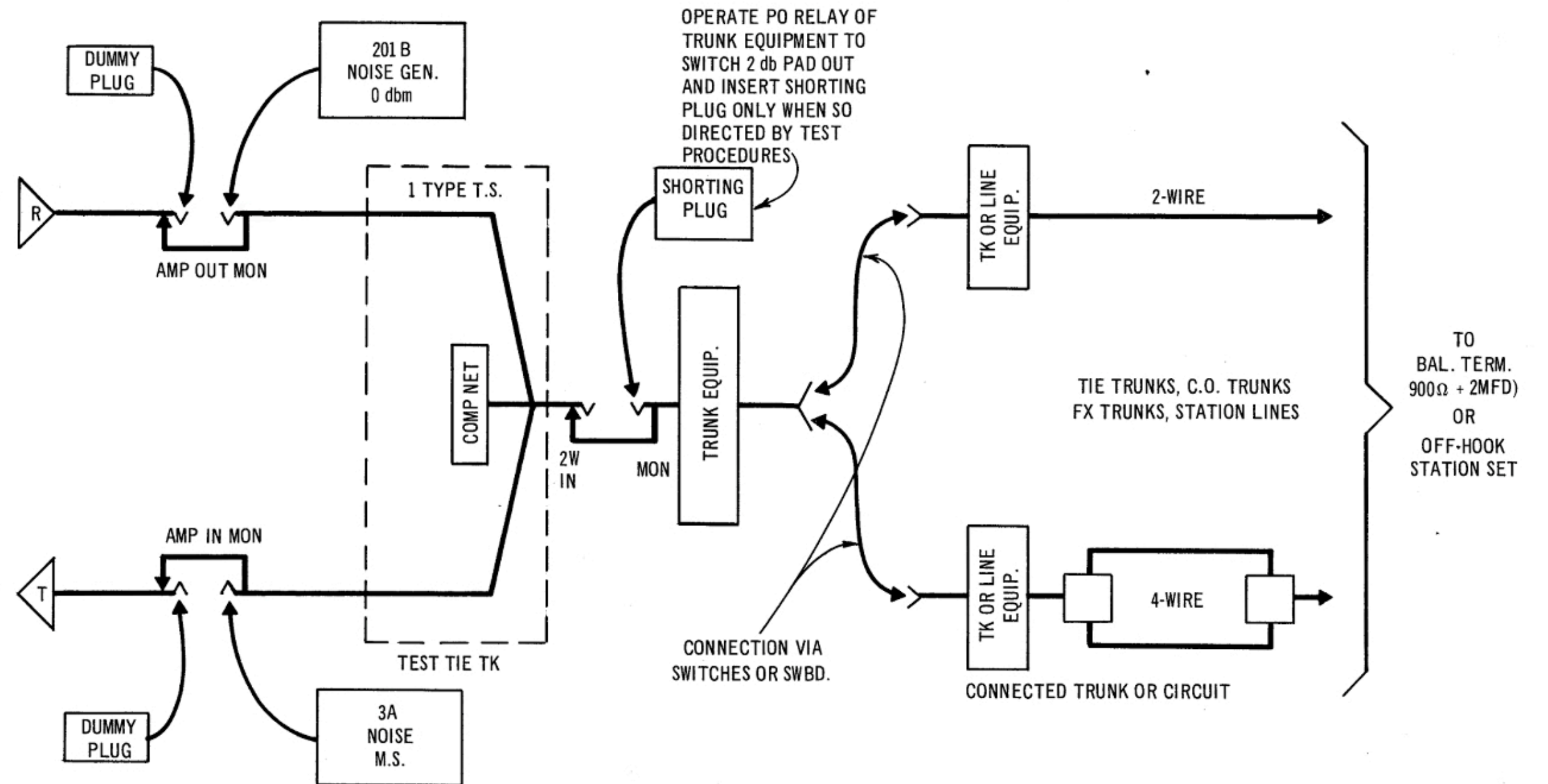

Fig. 6 — Terminal Balance Tests — Equipment Arrangement for Echo Return Loss Tests

10. TERMINAL BALANCE — SINGING POINT TESTS

10.01 Test equipment arrangements are shown in Fig. 7 for TERMINAL balance tests. The figure together with the following step-by-step procedures comprise the necessary testing to determine that the tie trunks meet the TERMINAL balance singing point requirements.

- Step 1 — Establish connection between selected test tie trunk and the connected circuit via the PBX switches. If tie trunks to be balanced are "manual only," establish connection via switchboard. Instructions for establishing either connection for TERMINAL balance are contained in Part 3.
- Step 2 — All screws on the front of the 1-type 4-wire term. set must be in the position specified on the circuit order card and the NBOC screws in the position determined in Part 6.
- Step 3 — Connect test equipment and terminate the connected circuit in accordance with Fig. 7.
- Step 4 — Plug 52-type headset into "MON" jack of 2D set and increase setting of 50 db gain attenuator clockwise until a sustained singing is heard in headset; then turn it back one step.
- Step 5 — Increase the setting of the 10 db gain attenuator slowly until sustained singing is just heard in the headset. Note the sum of the two attenuator dials at the point where singing just begins.
- Step 6 — Repeat Steps 4 and 5 with the poling key operated to reverse. A different value of attenuator settings will generally be obtained with the poling key reversed.
- Step 7 — The lower sum of the attenuator dial settings from the preceding tests is the measured singing point in db. Record this value in Col. D of Chart B. Restore gain attenuators to 0.
- Step 8 — Connect the equipment as shown in Fig. 8. Block the "PO" relay to switch the 2 db pad *OUT*. Insert the shorting plug into the 2-wire "MON" jack of the 4-wire term. set. Adjust the oscillator to send 1000 cycles at 0 dbm into the "IN" jack. Record the reading of the TMS detector in Col. E of Chart B. This is the singing point hybrid correction factor for the circuit under test. Remove the shorting plug and test equipment connectors and release "PO" relay.
- Step 9 — Subtract the hybrid correction factor (Step 8) from the measured singing point (Step 7). The difference is the singing point for this connection, and is recorded in Col. F of Chart B.
- Step 10 — Repeat the above procedures for the remainder of the sample selected for testing per Section 310-350-100, Par. 4.06-4.11.
- Step 11 — Compare the singing points obtained by testing with the objectives in Table B, to determine if corrective measures are required.

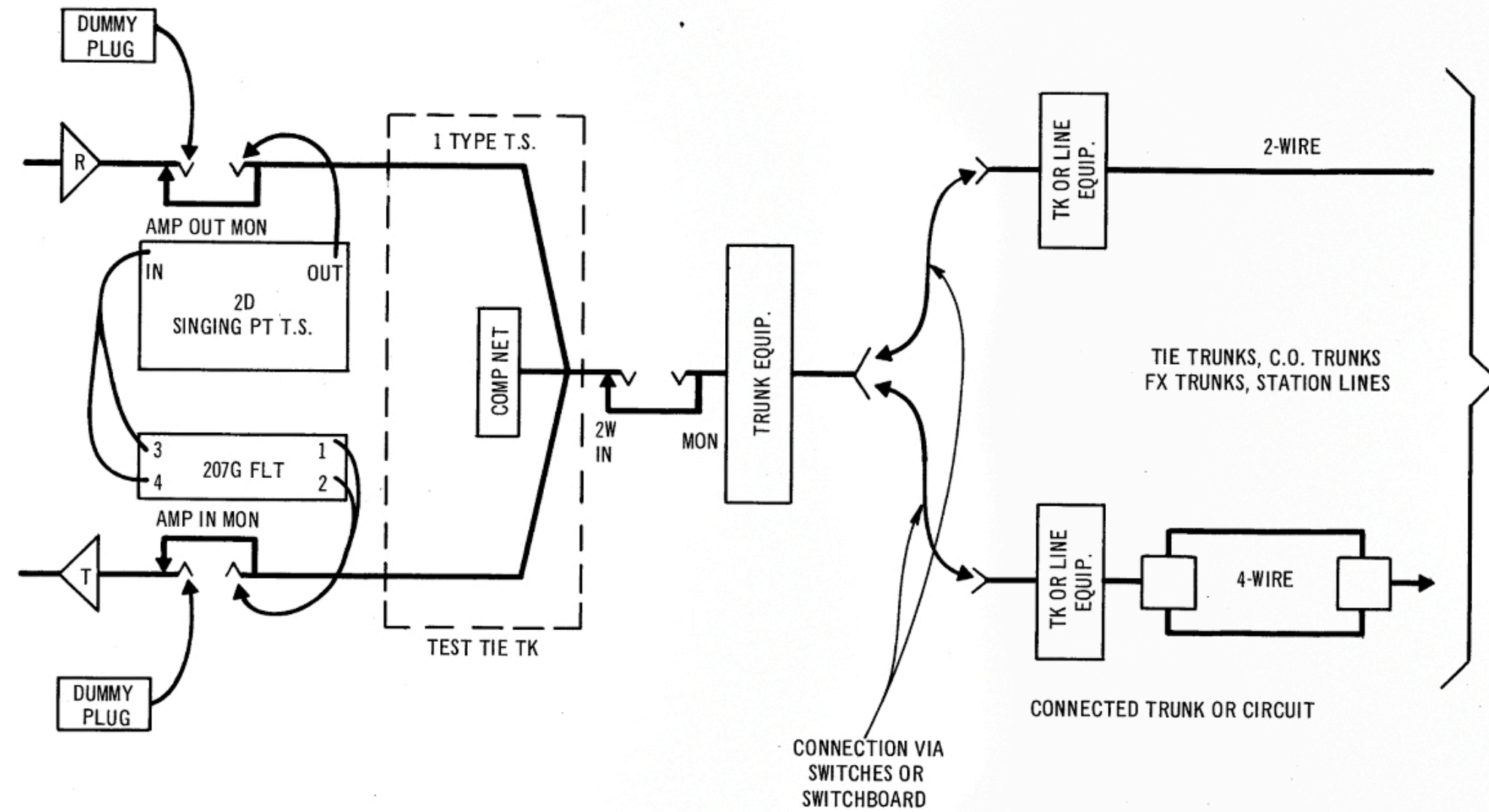

Fig. 7 - Terminal Balance Tests — Equipment Arrangement for Singing Point Test

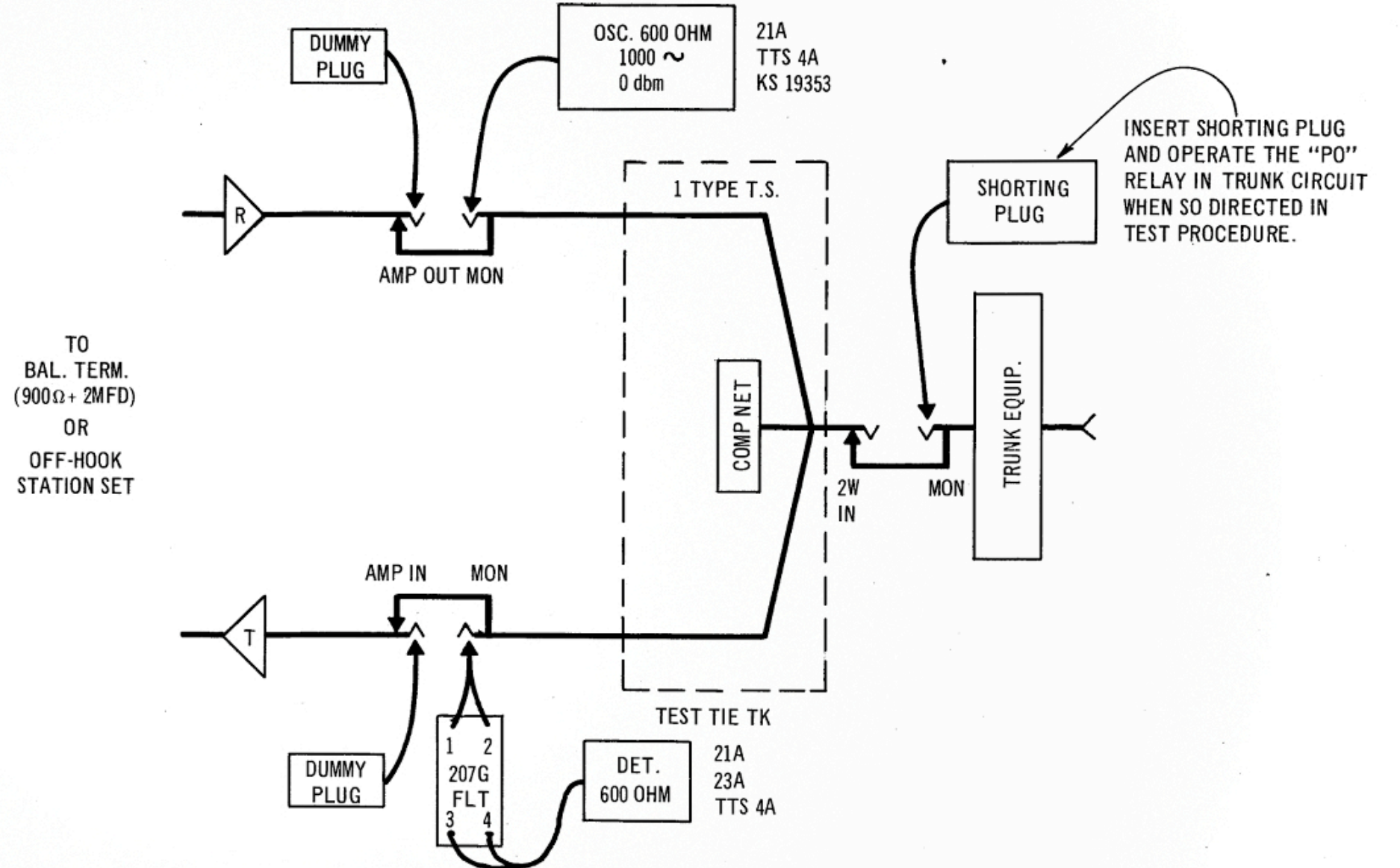

Fig. 8 - Singing Point Tests — Equipment Arrangement to Determine Hybrid Correction Factor

**TABLE B**  
**BALANCE MEASUREMENT OBJECTIVES**

TYPE CONNECTION	2 db SWITCH PAD	TYPE TEST	AVERAGE OF ALL TRUNK MEASUREMENTS	NO TRUNK MEASUREMENT LESS THAN	CONNECTED CIRCUIT TERMINATION
<b>THROUGH BALANCE</b>					
4-W VNL TIE TRUNK TO 4-W VNL TIE TRUNK	OUT	ERL SP	27.0 db 20.0 db	25.0 db 16.0 db	4-WIRE LEGS OF HYBRID TERMINATED IN 600 OHMS
<b>TERMINAL BALANCE</b>					
4-W VNL TIE TRUNK TO 4-W NON-VNL TIE TK	OUT	ERL SP	22.0 db 15.0 db	16.0 db 11.0 db	900 OHMS + 2 MF AT DISTANT PBX
TO 2-W NON-VNL TIE TK	OUT (NOTE 1)	ERL SP	18.0 db 10.0 db	13.0 db 6.0 db	900 OHMS + 2 MF AT DISTANT PBX
TO CENTRAL OFFICE OR FX TRUNK	OUT (NOTE 1)	ERL SP	SAME AS NON-VNL TIE TRUNKS		900 OHMS + 2 MF AT CENTRAL OFFICE
TO PBX STATION LINES	IN	ERL SP	24.0 db 18.0 db	20.0 db 14.0 db	900 OHMS + 2 MF AT PBX
		ERL SP	12.0 db 8.0 db	9.0 db 6.0 db	PBX STATION OFF HOOK

**NOTE 1:** If the facility loss is less than 2 db or adequate impedance correction is not provided, the 2 db pad cannot be switched out.



MEASUREMENT RECORD AND WORKSHEET

ECHO RETURN LOSS AND SINGING POINT TESTS { THRU BAL ✓  
 TERM. BAL

PBX George Company Plant #2 Location Anytown U.S.A.

DESIGNATION OF TEST TIE TRUNK	DESIGNATION OF CONNECTED CKT	CONNECTION VIA		ECHO RETURN LOSS (ERL)			SINGING POINT (SP)		
		SXS	SWB	MEASURED ERL (A)	HYBRID CORRECTION (B)	FINAL ERL (C)	MEASURED SP (D)	HYBRID CORRECTION (E)	FINAL SP (F)
Shellville #3	Alden #1		X	52.3 dbrn	81.5 dbrn	29.2	28.0	7.2	20.8
Shellville #5	"		X	51.8 dbrn	81.5 dbrn	29.7	28.0	7.2	20.8