

ENVELOPE DELAY CHARACTERISTICS OF 366- AND 367-TYPE EQUALIZERS

CONTENTS	PAGE
1. GENERAL	1
2. DESCRIPTION OF DELAY EQUALIZING UNIT	1
3. DESCRIPTION OF DELAY EQUALIZERS	3

1. GENERAL

1.01 This section describes the Delay Equalization Circuit per J99292-B used to provide prescription envelope delay equalization for various voice-frequency facilities. The section includes information on the characteristics of 367A, 366A, 366B and 366C plug-in equalizers. Changes have made it unnecessary to provide delay equalization for the voice-frequency portion of the TWX B1 trunk. 366D and 366E equalizers which were to be used for that purpose will not be manufactured. This section is reissued to provide the latest information.

1.02 The circuit was designed primarily for use with the B1 Data Carrier System, but is applicable to other 600-ohm voice-frequency bandwidth circuits requiring envelope delay equalization. It provides equalization and flat loss adjustment for one direction of transmission. A maximum of five voice sections can be equalized by a delay equalizing unit.

1.03 Included in the section are curves and tables describing the envelope delay characteristics and the attenuation-frequency characteristics of the various plug-in equalizers used in the circuit. Information on the delay and attenuation loss characteristics of the circuit between 600-ohm impedances at various frequencies is also included.

2. DESCRIPTION OF DELAY EQUALIZING UNIT

2.01 The Delay Equalizing Unit per J99292-B is a 4-wire device designed to operate between 600-ohm balanced impedances. A 1C Pad socket and access jacks are provided in one direction of transmission. In the reverse direction of transmission access jacks, an input transformer, a 9 db fixed isolation pad, positions to mount five 366-type Delay Equalizers, a 227A Amplifier, access jacks and a 1C Pad socket are provided. The 367-type Delay Equalizers and 426A Plugs can be mounted in place of the 366-type Delay Equalizers.

2.02 A delay equalizing unit is a fabricated metal shelf designed to mount on a 23-inch bulb angle bay having one-inch mounting centers, and equipped with a ten-inch guard rail. Each unit requires seven inches of mounting space. Seventeen units can be mounted in an 11-foot, 6-inch bay. All connections are made to a terminal strip mounted on the back of the shelf, which in turn, is cabled to a distributing frame.

2.03 Fig. 1 shows the shelf and the manner in which the plug-in equalizers are mounted.

2.04 Fig. 2 is a line drawing of the circuit for the delay equalizing unit.

2.05 The 1C pads provided in each direction of transmission are located under the coverplate on the right side of the equipment. They *must* be equipped with 89-type resistors for through transmission.

2.06 The 600-ohm transformer is used to couple the input line to the unbalanced equalizers. The 9 db pad improves the termination

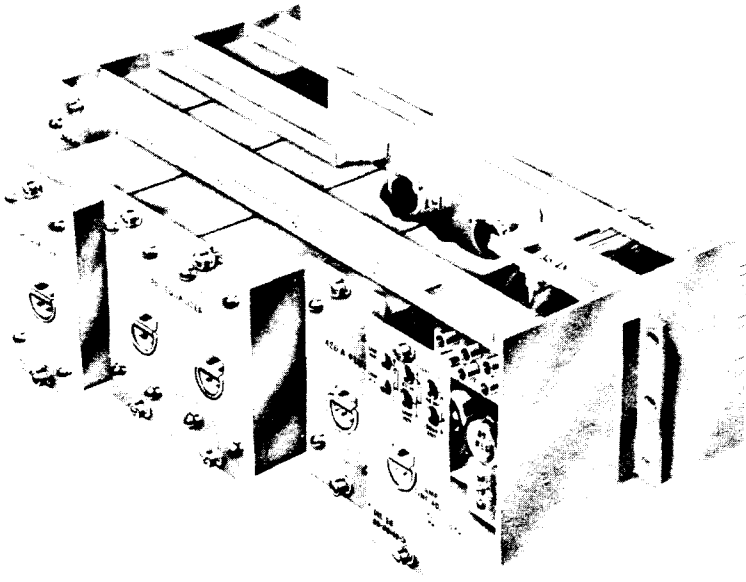

Fig. 1 - Delay Equalizing Unit

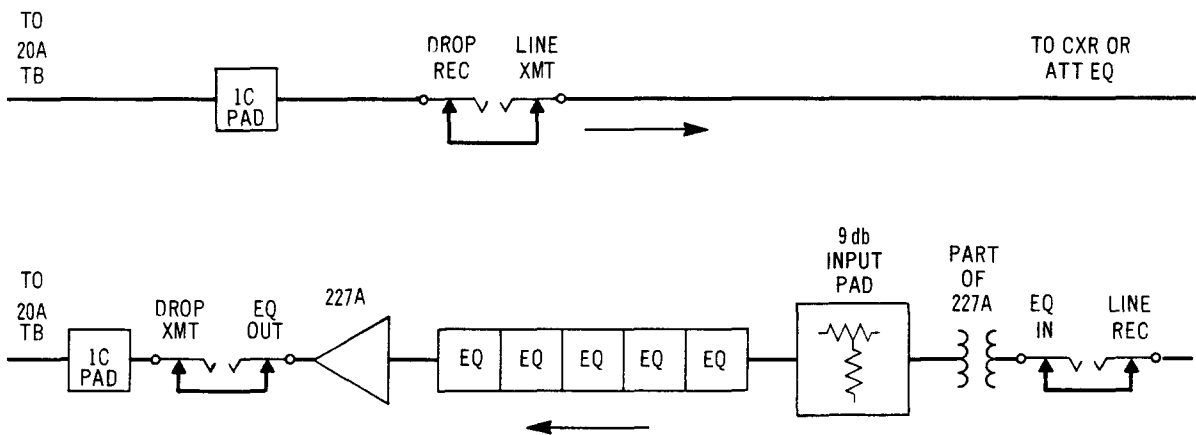

Fig. 2 - Delay Equalization Circuit

presented to the incoming line and to the equalizers. The 227 amplifier is used to couple the equalizers to the outgoing line and to compensate for the flat loss of the transformer, pad and equalizers. The 227A amplifier has a maximum output level of 16 dbm. The amplifier provides a coarse and fine gain adjustment in 3 ranges and provides from 0 to 35 db of gain. The fine adjustment has a range of 15 db and is accessible through a hole in the coverplate. The front coverplate must be removed before the coarse adjustment screws are accessible.

2.07 The five mounting positions within the delay equalizing unit are connected in series and must be filled with delay equalizers or 426A plugs. Delay equalizers are used on a 1-for-1 basis, depending on the composition of the trunk.

2.08 The average envelope delay characteristics for the delay Equalizer Unit, including the amplifier but not the delay equalizer, are given in Table I. The approximate loss of the delay equalizer unit relative to the 1200 cps loss is also tabulated.

TABLE I

FREQUENCY (Cycles)	ENVELOPE DELAY (Milliseconds)	LOSS (db)
300	.260	0.75
350	.195	0.60
400	.150	0.50
600	.085	0.25
800	.050	0.15
1000	.040	0.10
1200	.032	0.00
1500	.025	0.00
1800	.021	0.00
2200	.020	0.00
3000	.020	0.00
3300	.020	0.00

3. DESCRIPTION OF DELAY EQUALIZERS

3.01 Table II lists each equalizer available for use with the delay equalizing unit and the type of voice-frequency section it is designed to equalize.

TABLE II

EQUALIZER	SECTION EQUALIZED
366A	"A"-type Channel Bank Section
366B	N Carrier Section
366C	ON Carrier Section
367A	Two "A"-type Channel Bank Sections

3.02 Following are descriptions for the use of each equalizer:

(a) 366A Delay Equalizer

Provides delay equalization for a single section using "A"-type channel banks. Typical carrier systems are K, L, and J.

(b) 366B Delay Equalizer

Provides delay equalization for a single N section equipped with special service channel units. Where two carrier sections are interconnected using special service channel units, two delay equalizers are required.

(c) 366C Delay Equalizer

Provides delay equalization for a single ON section equipped with a special service channel unit and 529D or 529E filters. When two carrier sections are interconnected using special service channel units, two delay equalizers are required.

(d) 367A Delay Equalizer

Provides delay equalization for two "A"-type channel bank sections, connected in tandem, but not necessarily back to back. The 367A delay equalizer should be used in place of two 366A delay equalizers wherever possible, as the residual delay for a single 367A delay equalizer is generally less than that of two 366A delay equalizers. The 367A delay equalizer occupies the same amount of space as two 366A delay equalizers.

(e) 426A Plug

Mounts into a socket not filled with an equalizer to prevent having an open in the transmission path.

3.03 Table III gives the attenuation-frequency characteristics of the 366A-, 366B-, 366C- and 367A-type equalizers. Table IV gives the envelope delay characteristics of the 366A-, 366B-, 366C- and 367A-type equalizers.

3.04 Fig. 3 shows the nominal envelope delay for the delay equalizers available for use in the delay equalizing unit. Figs. 4 through 7 show the delay characteristics for the individual equalizers.

3.05 As an example of the effect of delay equalization Figs. 8 and 9 show the relative loss and envelope delay characteristics of a typical L multiplex circuit consisting of two pairs of type A channel banks with and without application of delay equalization.

TABLE III

EQUALIZER ATTENUATION — FREQUENCY CHARACTERISTICS

FREQUENCY (Cycles)	NOMINAL LOSS IN DB			
	367A	366A	366B	366C
300	7.99	4.28	2.80	3.42
350	8.10	4.09	2.96	3.49
400	7.45	3.91	3.05	3.58
500	7.20	3.75	3.15	3.70
600	7.51	3.95	3.25	3.80
700	7.88	4.00	3.35	3.84
800	8.04	4.13	3.42	3.88
900	8.34	4.26	3.47	3.89
1000	8.54	4.31	3.50	3.92
1100	8.71	4.44	3.50	3.95
1200	8.96	4.50	3.50	4.00
1300	8.97	4.58	3.50	4.03
1400	9.12	4.59	3.50	4.08
1500	9.19	4.65	3.50	4.10
1600	9.15	4.68	3.50	4.15
1700	9.17	4.70	3.50	4.21
1800	9.14	4.68	3.50	4.30
1900	9.08	4.64	3.50	4.33
2000	8.93	4.60	3.50	4.38
2100	8.93	4.58	3.50	4.44
2200	8.90	4.58	3.50	4.52
2300	8.83	4.52	3.49	4.58
2400	8.78	4.50	3.48	4.62
2500	8.71	4.50	3.47	4.65
2600	8.69	4.49	3.45	4.68
2700	8.55	4.47	3.42	4.69
2800	8.50	4.41	3.38	4.68
2900	8.42	4.39	3.32	4.65
3000	8.33	4.27	3.25	4.60
3100	8.06	4.18	3.14	4.49
3200	7.69	4.07	3.00	4.38
3250	7.54	3.95	2.90	4.29
3300	6.88	3.62	2.80	4.22

TABLE IV

EQUALIZER ENVELOPE DELAY CHARACTERISTICS

FREQUENCY (Cycles)	NOMINAL ENVELOPE DELAY IN MILLISECONDS			
	367A	366A	366B	366C
300	4.31	2.57	2.23	2.32
350	5.36	3.14	2.40	2.81
400	6.09	3.46	2.48	3.01
500	6.88	3.86	2.57	3.31
600	7.24	4.04	2.64	3.56
700	7.47	4.15	2.67	3.69
800	7.64	4.24	2.69	3.80
900	7.80	4.32	2.70	3.87
1000	7.93	4.38	2.71	3.93
1100	7.99	4.41	2.71	3.98
1200	8.07	4.45	2.72	4.02
1300	8.12	4.48	2.71	4.05
1400	8.16	4.50	2.71	4.07
1500	8.20	4.52	2.71	4.08
1600	8.23	4.53	2.71	4.11
1700	8.25	4.54	2.70	4.11
1800	8.26	4.55	2.70	4.12
1900	8.25	4.54	2.69	4.12
2000	8.24	4.53	2.68	4.12
2100	8.22	4.53	2.67	4.11
2200	8.19	4.51	2.65	4.10
2300	8.15	4.49	2.63	4.09
2400	8.10	4.47	2.61	4.08
2500	8.04	4.44	2.58	4.06
2600	7.96	4.40	2.56	4.03
2700	7.86	4.35	2.52	4.00
2800	7.74	4.29	2.49	3.96
2900	7.63	4.23	2.44	3.91
3000	7.42	4.13	2.39	3.85
3100	7.16	4.00	2.33	3.77
3200	6.70	3.77	2.24	3.65
3250	6.30	3.58	2.17	3.56
3300	5.82	3.33	2.09	3.46

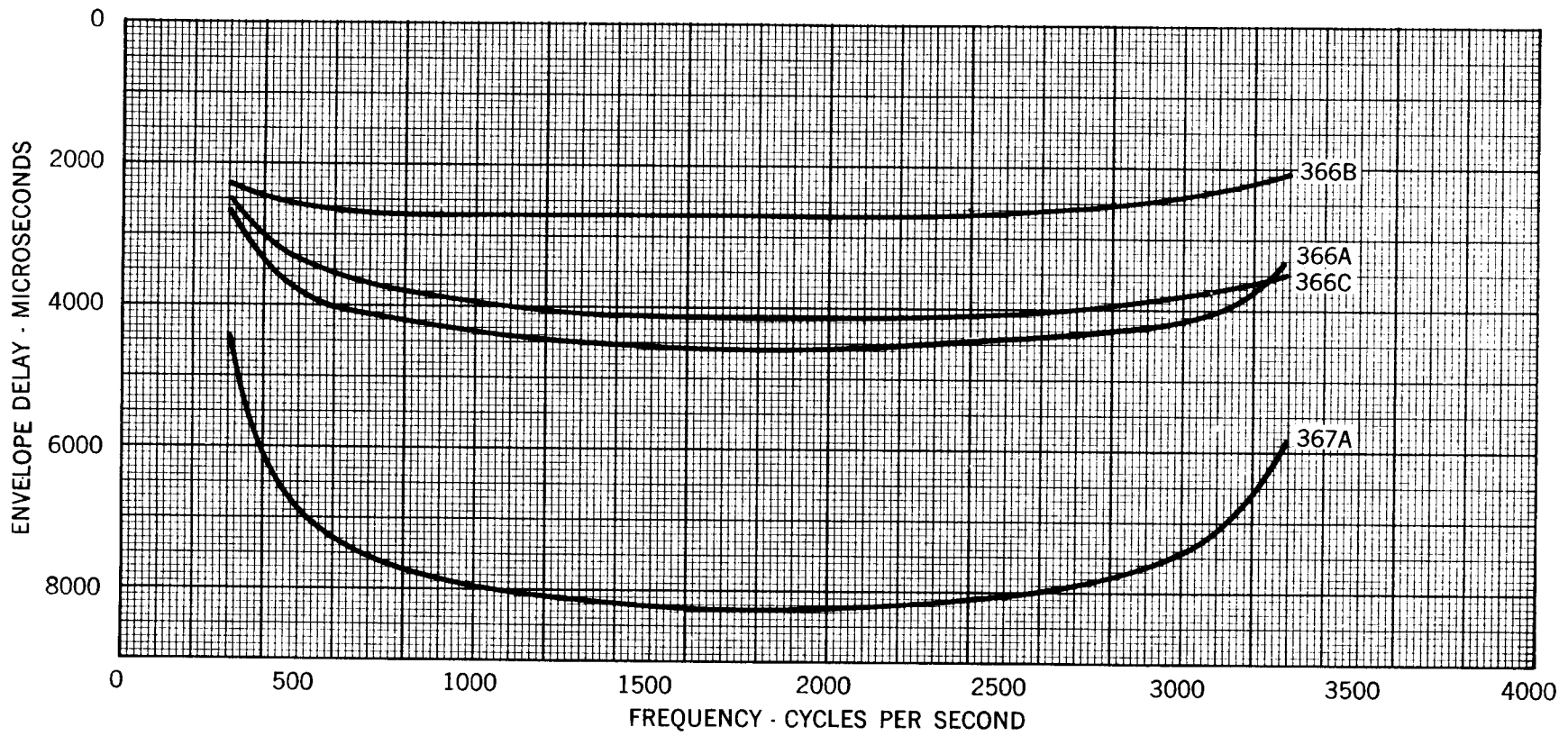

Fig. 3 – Nominal Envelope Delay Characteristics for 366- and 367-type Equalizers

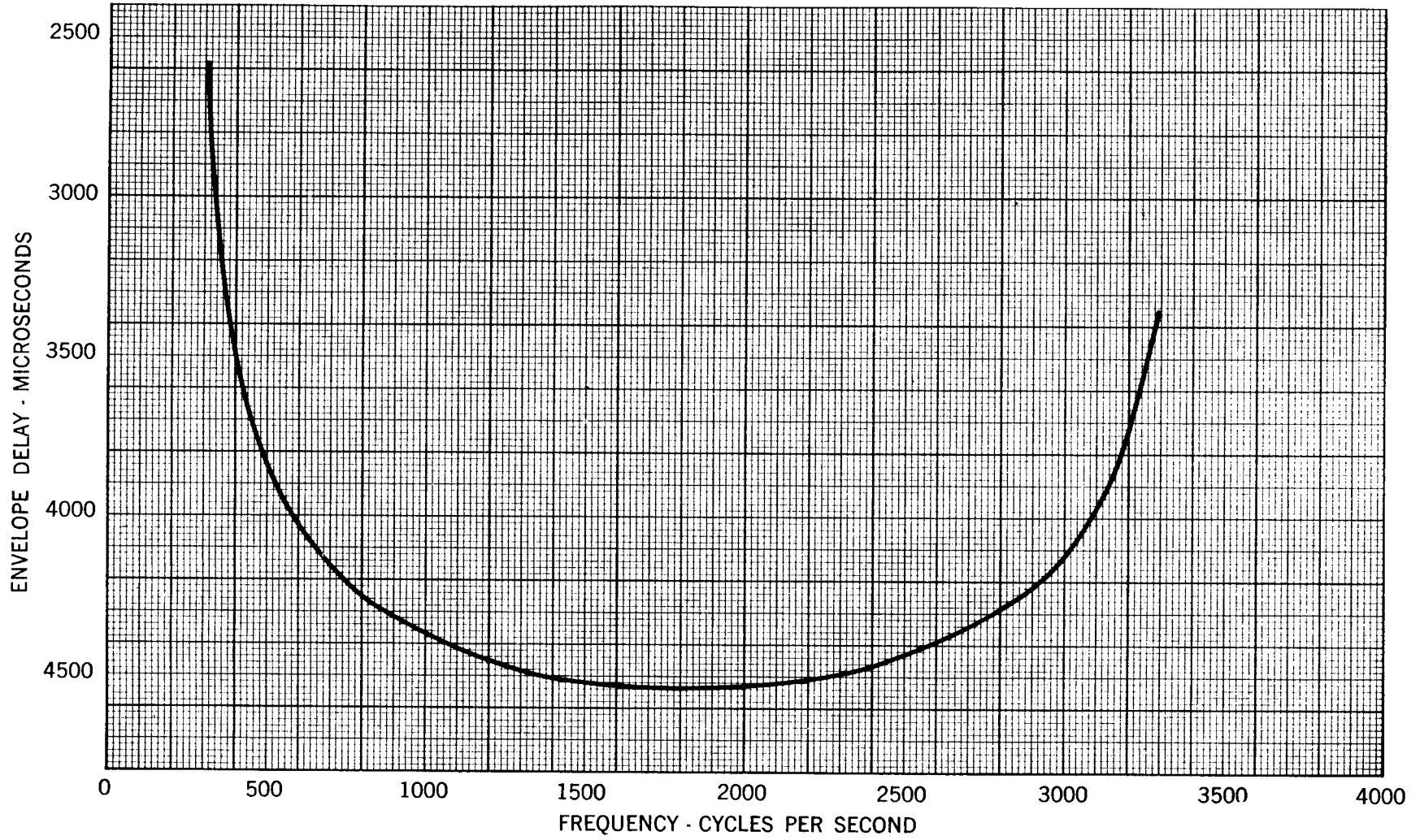

Fig. 4 – Nominal Envelope Delay Characteristic of 366A Equalizer

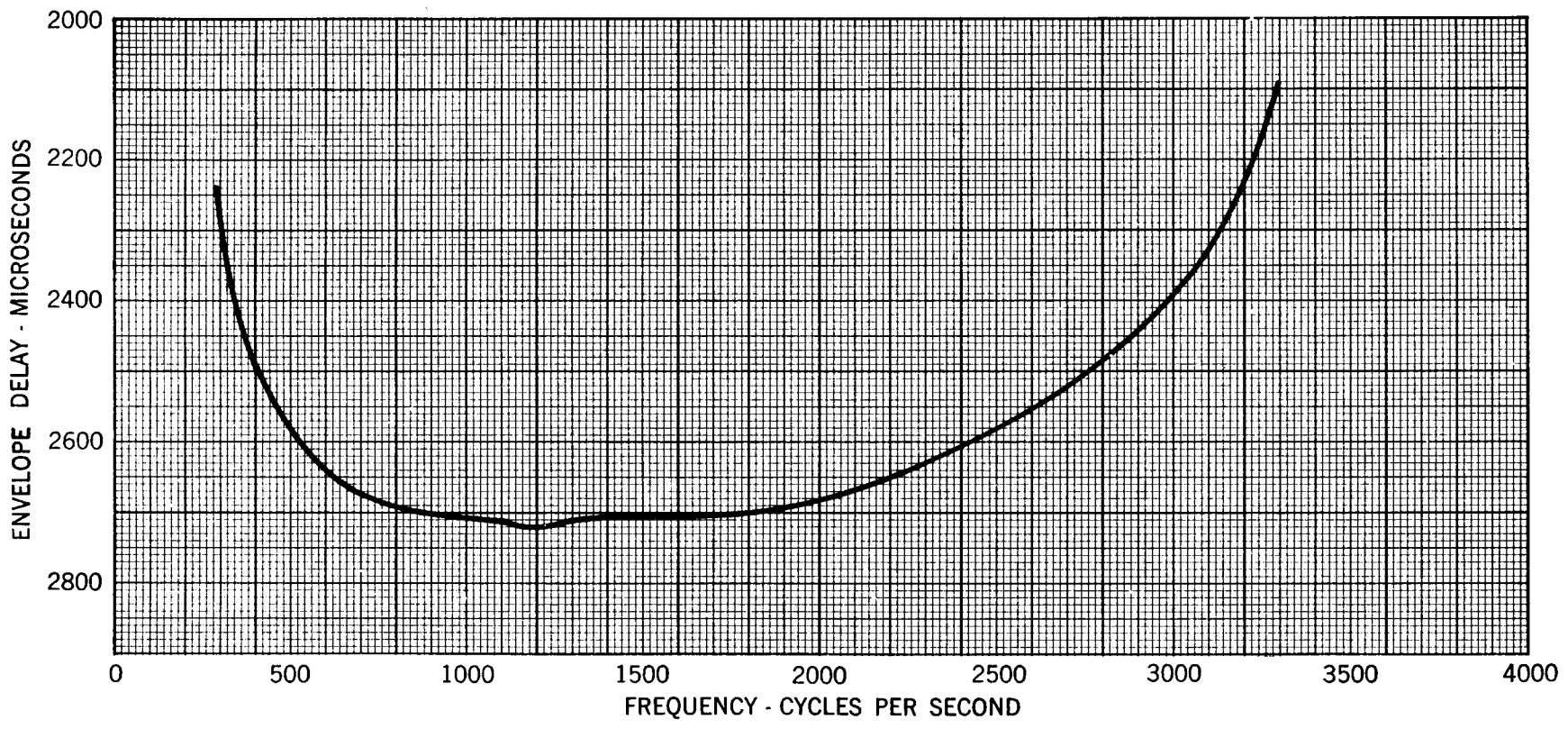

Fig. 5 – Nominal Envelope Delay Characteristic of 366B Equalizer

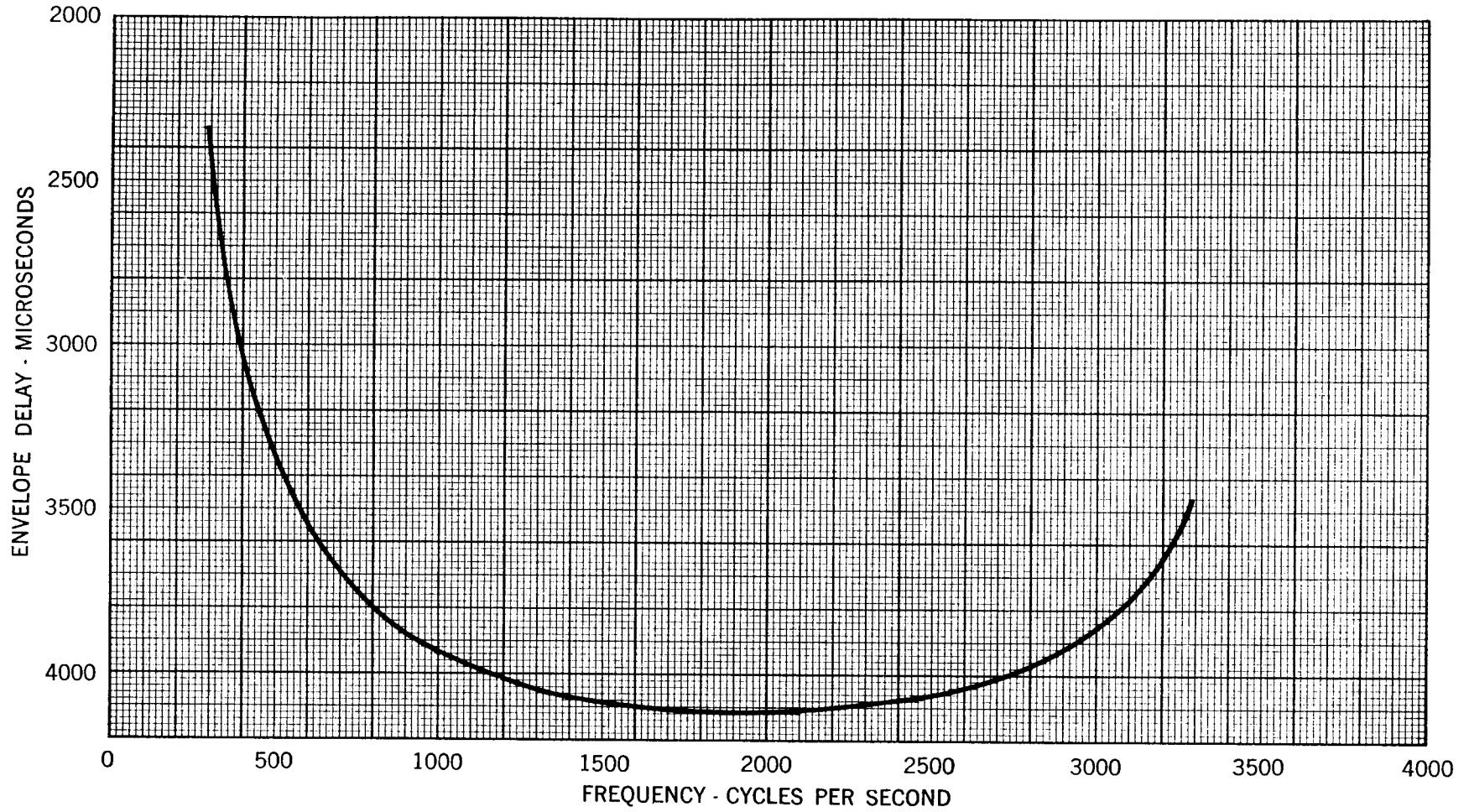

Fig. 6 – Nominal Envelope Delay Characteristic of 366C Equalizer

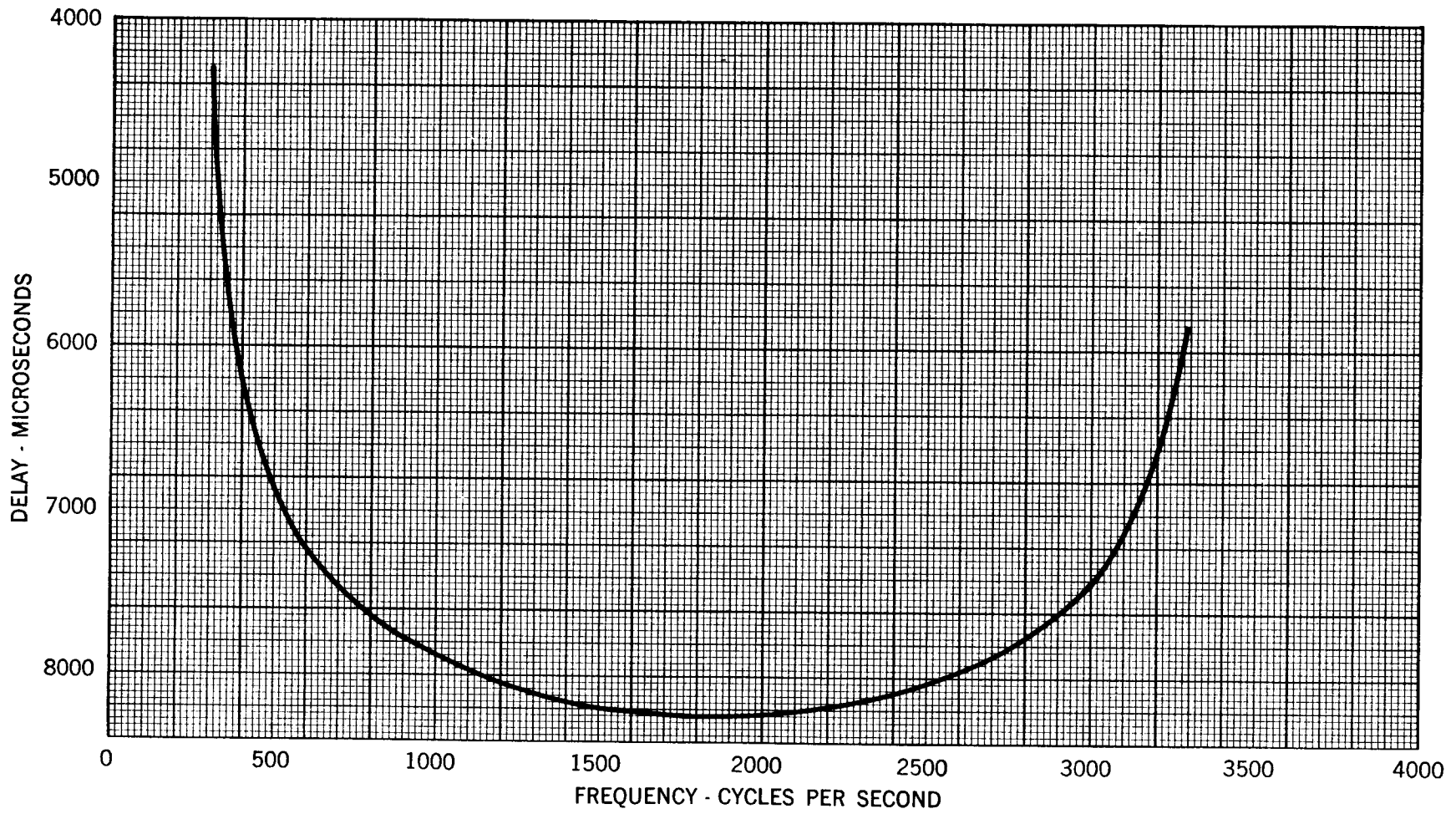

Fig. 7 – Nominal Envelope Delay Characteristic of 367A Equalizer

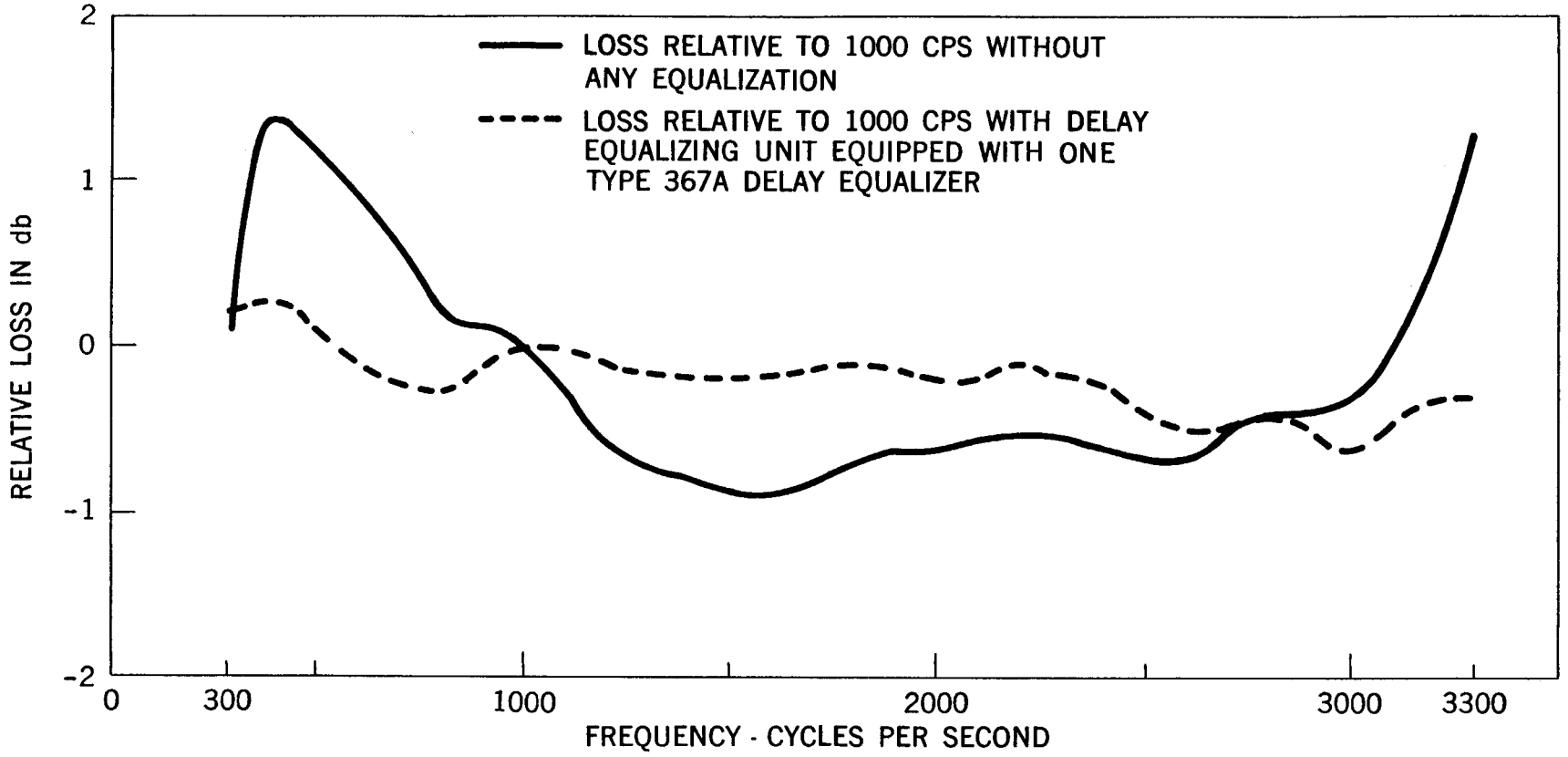

Fig. 8 - Relative Loss of Typical L Multiplex Circuit

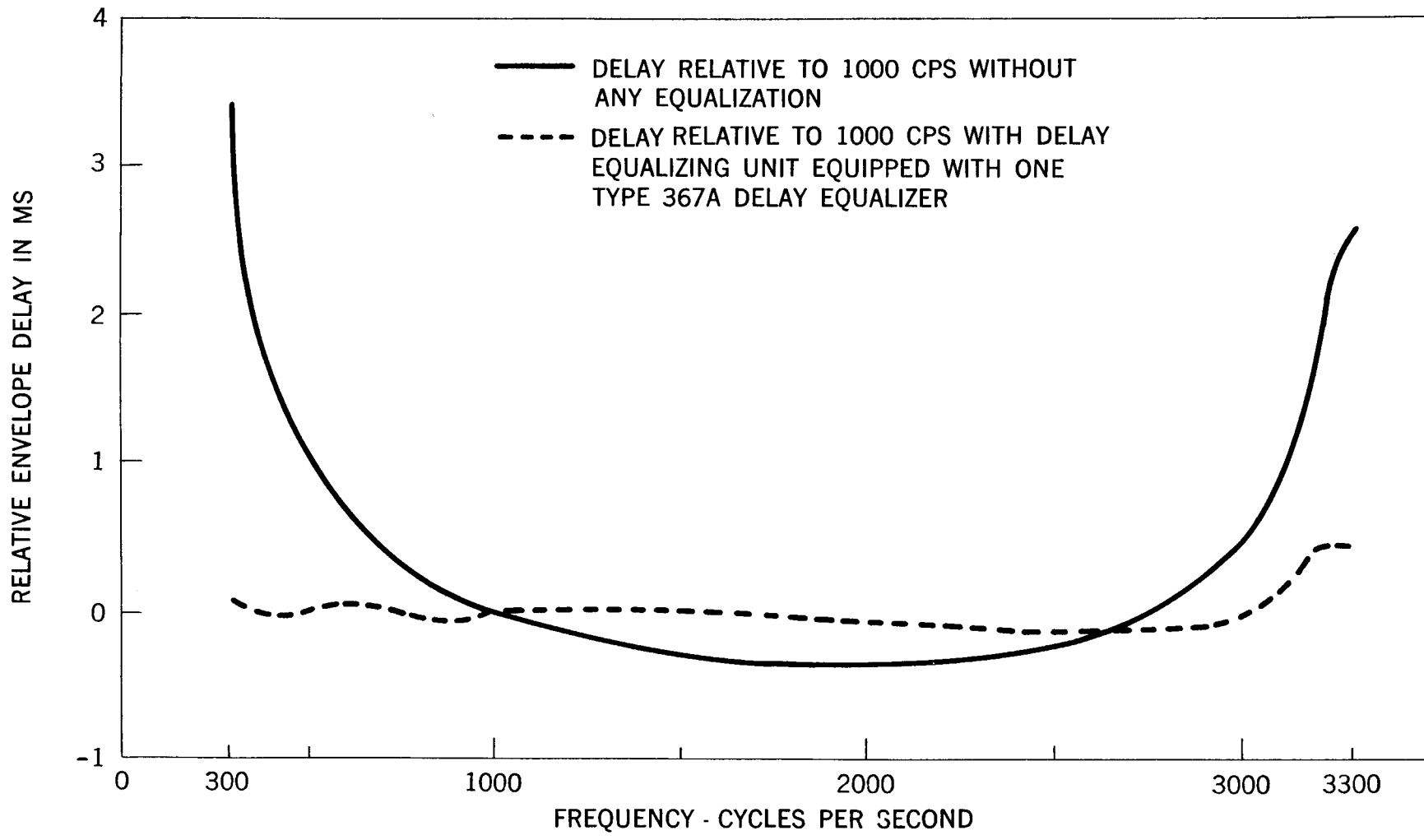

Fig. 9 - Relative Envelope Delay of Typical L Multiplex Circuit