

830E NETWORK INSTALLATION AND PRESCRIPTION SETTINGS

CONTENTS	PAGE
1. GENERAL	1
2. INSTALLATION	1
3. PERFORMANCE	1
A. Standard Design	1
B. Expected Performance	1
4. PRESERVICE TESTING	3
5. PRESCRIPTION SETTINGS	4
A. Example 1	4
B. Example 2	4
C. Example of 4066H Setting	4

3. PERFORMANCE

3.01 This part of the section discusses the expected performance of the 830E network when the prescription settings given in the tables are used. Also discussed are some reasons why the expected performance may not be attained and measures that can be taken to correct those situations.

A. Standard Design

3.02 The prescription settings given in the tables are for use on standard design, switched special service circuits as described in Section 851-300-101. This, of course, does not preclude the use of prescription settings on other switched or nonswitched special service circuits where the facilities used are like those listed in the tables. When a circuit does not qualify as a standard design the tables may be used for initial setting of the 830E network, and the circuit may then be aligned according to the appropriate 311- series section.

3.03 Prescription settings will apply to 3 dB circuits (eg, PBX-CO trunks) and to 1 dB links of special service circuits. These settings are also expected to apply to other special service circuits which do not require terminal balance. The best return loss and stability performance with the prescription settings will be realized when there are no bridged taps on the facility.

B. Expected Performance

3.04 The prescription settings in the tables for the facilities given are expected to allow the E6 repeater with an 830E network to meet an echo return loss (ERL) in the range from 14 to above 20 dB. The singing return loss at the high frequency end (SRL-HI) of the voice band is expected to be at least 12 dB. These return loss values are dependent on proper termination at the PBX (station) end, the effects of environmental variations, bridged tap limitations, cable record accuracy, and accuracy of the settings of the 830E

1. GENERAL

1.01 This section gives the installation procedure and prescription settings for the 830E network which is used in the E6 repeater on nonloaded links not requiring terminal balance. The 830E network equalizes the loss-frequency distortion of the nonloaded cable and matches the impedance of the gain unit in the E6 repeater.

1.02 When this section is reissued, the reason for reissue will be given in this paragraph.

1.03 The 830E network is described in Section 332-206-125.

2. INSTALLATION

2.01 The 830E network is usually mounted in the B side of the E6 repeater chassis, and is secured by four screws on the chassis connector block. These screws also make the required electrical connections between the network and repeater.

network components. These are discussed in more detail in the following paragraphs.

3.05 The losses of 3 dB 900 ohm circuits at lower and upper test frequencies, also known as insertion loss roll off, are well within the published requirements for voice frequency channels with no conditioning.

Station Terminations

3.06 Prescription settings for the 830E were developed to give the best ERL performance using either a 4066H network, which accurately simulates the impedance of an off-hook telephone set, or an off-hook telephone set with appropriate battery feed, at the PBX (or station) end of the circuit. Terminations consisting of either 600-ohm or 900-ohm resistors in series with a 2.16 μ F capacitor are not recommended. The ERL and SRL-HI measured with these terminations on a 3 dB circuit can be 3 to 10 dB lower than when measured with a 4066H network or a telephone set. ERL and SRL-HI can be even poorer on 1 dB links. If there is a POTS application where the termination is 600 ohms or 900 ohms in series with 2.16 μ F, the circuit should be lined up using the nearest setting listed in the tables and then touched up as described in 4.04.

Environmental Variations

3.07 The ERL and SRL-HI are somewhat sensitive to cable capacitance and to temperature variations. Also, ERL performance can vary by a few dB from one E6 repeater and/or 830E network to another because of manufacturing tolerances and aging of components.

Bridged Tap

3.08 The prescription settings given in the tables assume that there is no bridged tap on the facilities. If somewhat degraded ERL performance can be tolerated, bridged tap may be present as follows:

- (1) No bridged tap within 3 kft of the repeater.
- (2) No more than 1 kft of bridged tap out to 80 per cent of the cable working length.
- (3) Up to 2 kft of bridged tap may be present beyond the 80 percent point.

- (4) Bridged tap distributions (2) and (3) must not be present simultaneously.

3.09 The C screw is sometimes used to add capacitance to offset the effects of long bridged taps (3 to 6 kft). When the circuit layout record (CLR) card specifies the C screw down, the circuit may have to be lined up manually. A computer program, Universal Cable Circuit Analysis Program (UNICCAP), described in Section 856-100-100 is available to compute settings for facilities with or without bridged taps.

Cable Record Accuracy

3.10 Accurate knowledge of cable lengths and gauges including length and location of bridged tap is essential for prescription setting of the networks. The E6 repeater with an 830E network is near its design limits for lengths of cable greater than 14 kft of 26 gauge or greater than 17 kft of 24 gauge without bridged taps. In these instances performance degradation and the likelihood of singing circuits may occur even with manual line up.

Accuracy of Dial Settings

3.11 Maladjustment of the R1 and R2 dials on the 830E network will cause a degradation in return loss performance. Both dials should be set as accurately as possible, however ERL is most sensitive to the setting for R1. Therefore, this adjustment should be set as precisely as possible. Fig. 1 is an example of a dial setting of either R1 or R2.

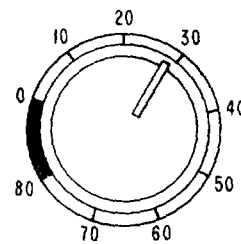

THE ABOVE FIGURE REPRESENTS A DIAL SETTING OF 28 ON EITHER R1 OR R2. THE 830E DIALS HAVE EIGHT RAISED NOTCHES AND THE SETTING IN TABLES B THROUGH G ARE BASED ON INCREMENTS OF ONE UNIT ON A SCALE OF 0 TO 80. ZERO IS FULLY COUNTERCLOCKWISE.

Fig. 1—Potentiometer Dial Settings

4. PRESERVICE TESTING

4.01 Even though the 830E network settings may be used as true prescription settings, a check of ERL and SRL-HI is recommended when the E6 is installed in a circuit and prior to the circuit being turned up for service. Any one or a combination of the previously mentioned performance-affecting variables may possibly cause degradation of ERL below that which is acceptable.

4.02 The following procedure is recommended upon installation of the E6 with an 830E network. Prescription settings should be obtained from the CLR card or from the appropriate table for the length and gauge of cable. (See example in 5.02). These settings should be carefully and accurately set into the network.

4.03 Measurements should be made of 1 kHz insertion loss, ie, the expected measured loss (EML) as given on the CLR card, and of the insertion loss at the lower and upper test frequencies. These loss measurements must be acceptable before making return loss measurements.

4.04 Measure ERL and SRL-HI of the circuit using a KS-20501 return loss measuring set (RLMS) or a 54C RLMS. Fig. 2 shows the recommended test configuration. The ERL should measure at least 20 dB and SRL-HI should measure at least 12 dB. If these values are not obtained with the prescription settings given, corrective action should be tried as follows:

(a) Try the prescription settings listed adjacent to the ones originally chosen, especially in

those instances where the facility length is suspected to be near the boundary of the settings used. Retain the settings which give better ERL, unless SRL-HI has seriously decreased.

(b) If (a) does not correct the return loss, adjust R1 for peak ERL on the RLMS.

(c) If return loss requirements are still not met, increase the value of inductance by 0.05 over the prescribed value. For example, if the prescribed inductance value is 0.55, screws .4, .1, and .05 are up (the remaining screws, including L, are down). To increase the inductance to 0.60, screws .4 and .2 should be up and the remaining screws should be down. Readjust R1 if necessary. If this improves ERL, retain this setting.

(d) If increasing the inductance by 0.05 worsens the return loss performance, decrease the inductance by 0.05 below the prescribed value. Readjust R1 if necessary. If this improves ERL, retain this setting.

4.05 If the corrective action taken above does not improve return loss performance to the recommended values, then the circuit must be manually lined up as described in Section 311-240-502. Final adjustments of the 830E should be recorded on the CLR card.

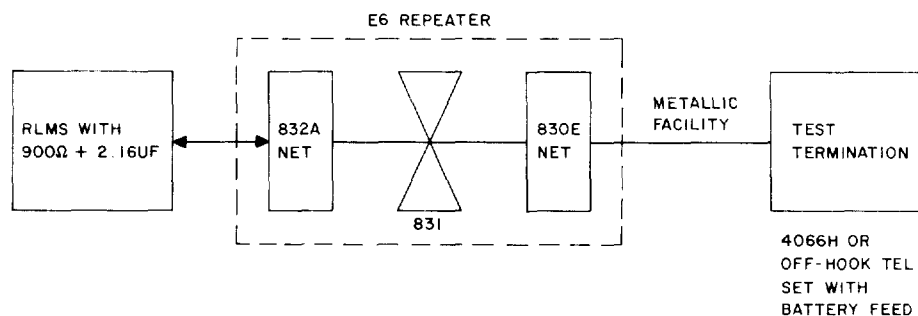

Fig. 2—Recommended Test Configuration

5. PRESCRIPTION SETTINGS

5.01 Table A lists the tables which give prescription settings for the 830E network for varying lengths of facilities, both single gauge and mixed gauge. Following Table A are two examples of use of the tables.

TABLE A

TABLE	CABLE GAUGE	FACILITY LENGTH (KFT)
B	22	2-18
C	24	3-17.5
D	26	2-14.5
E	26-24	3-14
F	26-22	5-15
G	24-22	8-18

A. Example 1

5.02 Assume a circuit which has 10.4 kft of 26-gauge nonloaded cable and no bridged tap. From Table D, the settings are;

- Cable length (kft) 10-11
- R1 27
- R2 16
- L down
- .05 up
- .1 up
- .2 up
- .4 down
- .8 down
- R up
- BORs down
- C up

B. Example 2

5.03 Assume a circuit which has 9.7 kft of mixed 24- and 22-gauge nonloaded cable and no bridged tap. There are 6.4 kft of 24 gauge and 3.3 kft of 22 gauge. Table G contains information for mixed 24- and 22-gauge cable. Mixed gauge settings are determined by rounding the actual length combination of the facility to the nearest kilofoot. However, rather than the overall length controlling, the individual lengths control. In this example, 6.4 kft of 24 gauge is rounded to 6 kft, and 3.3 kft of 22 gauge is rounded to 3 kft. In Table G, the following is found:

- Cable length — 9 kft overall
- Cable length — 6 kft 24 ga.
- Cable length — 3 kft 22 ga.
- R1 39
- R2 61
- L down
- .05 down
- .1 down
- .2 down
- .4 up
- .8 down
- R up
- BORs down
- C up

C. Example of 4066H Setting

5.04 Using the cable facility in Example 2, compute the required screw setting of the 4066H test termination as follows.

- 830E network resistance = 121Ω BOR out
- 830E network resistance = 271Ω BOR in
- Battery feed resistance = 400Ω
- E6 repeater resistance = 45Ω
- Telephone set resistance = 200Ω

Cable resistance: 6.4 kft 24 ga. = 332Ω @ 68°F

Cable resistance: 3.3 kft 22 ga. = 107Ω @ 68°F

Assuming 48v battery at office, loop current equals $48/1205 = .040$ a or 40 ma. From Table H, the B screw will be down on the 4066H network.

Total loop resistance in facility is (BORs out); 121
 $+ 400 + 45 + 200 + 332 + 107 = 1205\Omega$.

TABLE B

830E NETWORK PRESCRIPTION SETTINGS FOR 22 GAUGE CABLE
 NONLOADED LINKS WITHOUT BRIDGED TAP

CABLE LENGTH KFT	POTENTIOMETER SETTINGS		INDUCTANCE SETTINGS* L SCREW IS DOWN					R*	BOR*	C*	4066H TERMINATING NETWORK SCREW DOWN
	R1	R2	.05	.1	.2	.4	.8				
2-4	52	9		X	X	X	X	X			B
4-5	46	14	X		X	X	X	X			B
5-7	43	36			X	X	X	X			B
7-8	42	80	X	X		X	X	X			B
8-10	37	24				X	X	X			B
10-11	33	7		X	X		X	X			B
11-13	31	8	X		X		X	X			B
13-14	30	48	X	X	X	X			X		B
14-16	27	36		X	X	X			X		B
16-17	24	26	X		X	X			X		B
17-18	22	19			X	X			X		A

* X indicates screws down.

TABLE C

830E NETWORK PRESCRIPTION SETTINGS FOR 24 GAUGE CABLE
NONLOADED LINKS WITHOUT BRIDGED TAP

CABLE LENGTH KFT	POTENTIOMETER SETTINGS		INDUCTANCE SETTINGS* L SCREW IS DOWN					R*	BOR*	C*	4066H TERMINATING NETWORK SCREW DOWN
	R1	R2	.05	.1	.2	.4	.8				
3-5	45	11		X	X	X	X	X			B
5-7.5	43	80		X	X	X	X	X			B
7.5-10.0	40	80		X	X		X		X		B
10.0-13.0	30	38			X		X		X		A
13.0-14.5	26	24	X	X			X		X		A
14.5-17.0	24	12		X			X		X		A
17.0-17.5	21	0					X		X		A

* X indicates screws down.

TABLE D

830E NETWORK PRESCRIPTION SETTINGS FOR 26 GAUGE CABLE
NONLOADED LINKS WITHOUT BRIDGED TAP

CABLE LENGTH KFT	POTENTIOMETER SETTINGS		INDUCTANCE SETTINGS* L SCREW IS DOWN					R*	BOR*	C*	4066H TERMINATING NETWORK SCREW DOWN
	R1	R2	.05	.1	.2	.4	.8				
2-4	45	0	X	X	X	X	X	X			B
4-5.5	40	17	X	X	X	X	X	X			B
5.5-7.0	42	80			X	X	X		X		B
7.0-8.5	36	80		X		X	X		X		A
8.5-10.0	32	69	X			X	X		X		A
10.0-11.0	27	16				X	X		X		A
11.0-13.0	24	2	X	X	X		X		X		A
13.0-14.5	23	0		X	X		X		X		A

* X indicates screws down.

TABLE E

830E NETWORK PRESCRIPTION SETTINGS FOR MIXED 26-24 GAUGE CABLE WITH
26 GAUGE NEAREST THE REPEATER AND WITHOUT BRIDGED TAPS

CABLE LENGTH (KFT)			POTENTIOMETER SETTINGS		INDUCTANCE SETTINGS* L SCREW DOWN					R*	BOR*	C*	4066H SCREW DOWN
OVERALL	26 GA	24 GA	R1	R2	.05	.1	.2	.4	.8				
3	1	2	45	7		X	X	X	X	X			B
	2	1	45	4	X	X	X	X	X	X			B
4	1	3	45	13		X	X	X	X	X			B
	2	2	42	14	X	X	X	X	X	X			B
	3	1	42	15	X	X	X	X	X	X			B
5	1	4	43	67		X	X	X	X	X			B
	2	3	42	54		X	X	X	X	X			B
	3	2	41	43	X	X	X	X	X	X			B
	4	1	40	30	X	X	X	X	X	X			B
6	1	5	43	80		X	X	X	X	X			B
	2	4	43	80		X	X	X	X	X			B
	3	3	42	80	X		X	X	X		X		B
	4	2	42	80			X	X	X		X		B
	5	1	42	80			X	X	X		X		B
7	1	6	43	80		X	X	X	X	X			B
	2	5	42	80	X		X	X	X		X		A
	3	4	41	80			X	X	X		X		A
	4	3	38	80			X	X	X		X		A
	5	2	37	80	X	X		X	X		X		A
	6	1	36	80		X		X	X		X		A
8	1	7	40	80		X	X		X		X		A
	2	6	39	80	X	X	X		X		X		A
	3	5	39	80	X	X	X		X		X		A
	4	4	38	80				X	X		X		A
	5	3	37	80	X			X	X		X		A
	6	2	37	80	X			X	X		X		A
	7	1	36	80		X		X	X		X		A
9	1	8	40	79		X	X		X		X		A
	2	7	39	77		X	X		X		X		A
	3	6	38	76	X	X	X		X		X		A
	4	5	37	75	X	X	X		X		X		A

TABLE E (Cont)

CABLE LENGTH (KFT)			POTENTIOMETER SETTINGS		INDUCTANCE SETTINGS* L SCREW DOWN					R*	BOR*	C*	4066H SCREW DOWN
OVERALL	26 GA	24 GA	R1	R2	.05	.1	.2	.4	.8				
9 (Cont)	5	4	35	74				X	X		X		A
	6	3	34	73				X	X		X		A
	7	2	33	72	X			X	X		X		A
	8	1	32	70	X			X	X		X		A
10	1	9	30	36			X		X		X		A
	2	8	30	33			X		X		X		A
	3	7	29	31	X		X		X		X		A
	4	6	29	29	X		X		X		X		A
	5	5	28	28		X	X		X		X		A
	6	4	28	25	X	X	X		X		X		A
	7	3	28	23	X	X	X		X		X		A
	8	2	27	21				X	X		X		A
	9	1	27	18				X	X		X		A
11	1	10	30	38			X		X		X		A
	2	9	30	38			X		X		X		A
	3	8	30	31	X	X	X		X		X		A
	4	7	30	31	X	X	X		X		X		A
	5	6	30	31	X	X	X		X		X		A
	6	5	30	31	X	X	X		X		X		A
	7	4	30	31	X	X	X		X		X		A
	8	3	30	31	X	X	X		X		X		A
	9	2	30	31	X	X	X		X		X		A
	10	1	24	2	X	X	X		X		X		A
12	1	11	30	38			X		X		X		A
	2	10	28	19	X		X		X		X		A
	3	9	28	19	X		X		X		X		A
	4	8	28	19	X		X		X		X		A
	5	7	28	19	X		X		X		X		A
	6	6	28	19	X		X		X		X		A
	7	5	28	19		X	X		X		X		A
	8	4	28	19		X	X		X		X		A
	9	3	28	19		X	X		X		X		A

TABLE E (Cont)

CABLE LENGTH (KFT)			POTENTIOMETER SETTINGS		INDUCTANCE SETTINGS* L SCREW DOWN					R*	BOR*	C*	4066H SCREW DOWN
OVERALL	26 GA	24 GA	R1	R2	.05	.1	.2	.4	.8				
12 (Cont)	10	2	28	19		X	X		X		X		A
	11	1	28	19		X	X		X		X		A
13	1	12	26	24	X	X			X		X		A
	2	11	27	8			X		X		X		A
	3	10	27	8			X		X		X		A
	4	9	27	8			X		X		X		A
	5	8	27	8			X		X		X		A
	6	7	26	0	X		X		X		X		A
	7	6	26	0	X		X		X		X		A
	8	5	26	0	X		X		X		X		A
	9	4	26	0	X		X		X		X		A
	10	3	26	0	X		X		X		X		A
	11	2	23	0		X	X		X		X		A
	12	1	23	0		X	X		X		X		A
14	1	13	26	24	X	X			X		X		A
	2	12	26	0	X	X			X		X		A
	3	11	26	0	X	X			X		X		A
	4	10	26	0	X	X			X		X		A
	5	9	25	0			X		X		X		A
	6	8	25	0			X		X		X		A
	7	7	25	0			X		X		X		A
	8	6	25	0	X		X		X		X		A
	9	5	25	0	X		X		X		X		A
	10	4	25	0	X		X		X		X		A
	11	3	24	0	X		X		X		X		A
	12	2	24	0	X		X		X		X		A
	13	1	24	0	X		X		X		X		A

* X indicates screws down.

TABLE F

830E NETWORK PRESCRIPTION SETTINGS FOR MIXED 26-22 GAUGE CABLE WITH
26 GAUGE NEAREST THE REPEATER AND WITHOUT BRIDGED TAPS

CABLE LENGTH (KFT)			POTENTIOMETER SETTINGS		INDUCTANCE SETTINGS* L SCREW DOWN					R*	BOR*	C*	4066H SCREW DOWN
OVERALL	26 GA	22 GA	R1	R2	.05	.1	.2	.4	.8				
5	1	4	44	27		X	X	X	X	X			B
	2	3	42	35	X		X	X	X	X			B
	3	2	41	25		X	X	X	X	X			B
	4	1	40	21	X	X	X	X	X	X			B
6	1	5	43	44			X	X	X	X			B
	2	4	43	51			X	X	X	X			B
	3	3	42	57			X	X	X	X			B
	4	2	42	65			X	X	X		X		B
	5	1	42	72			X	X	X		X		B
7	1	6	42	80	X	X		X	X	X			B
	2	5	37	80	X	X		X	X	X			B
	3	4	39	80	X	X		X	X	X			B
	4	3	39	80		X		X	X		X		B
	5	2	37	80		X		X	X		X		B
	6	1	36	80		X		X	X		X		B
8	1	7	37	31				X	X	X			B
	2	6	37	38				X	X	X			B
	3	5	37	45	X			X	X		X		B
	4	4	36	51	X			X	X		X		B
	5	3	36	59	X			X	X		X		B
	6	2	36	66		X		X	X		X		A
	7	1	36	73		X		X	X		X		A
9	1	8	37	29				X	X	X			B
	2	7	36	34				X	X		X		B
	3	6	35	39				X	X		X		B
	4	5	34	44				X	X		X		A
	5	4	35	49	X			X	X		X		A
	6	3	34	54	X			X	X		X		A
	7	2	33	59	X			X	X		X		A
	8	1	32	64	X			X	X		X		A
10	1	9	36	42		X	X		X		X		A

TABLE F (Cont)

CABLE LENGTH (KFT)			POTENTIOMETER SETTINGS		INDUCTANCE SETTINGS* L SCREW DOWN					R*	BOR*	C*	4066H SCREW DOWN
OVERALL	26 GA	22 GA	R1	R2	.05	.1	.2	.4	.8				
10 (Cont)	2	8	36	42		X	X		X		X		A
	3	7	36	42		X	X		X		X		A
	4	6	36	42		X	X		X		X		A
	5	5	36	42		X	X		X		X		A
	6	4	33	46				X	X		X		A
	7	3	33	46				X	X		X		A
	8	2	27	16				X	X		X		A
	9	1	27	16				X	X		X		A
11	1	10	35	32			X		X		X		A
	2	9	35	32			X		X		X		A
	3	8	35	32			X		X		X		A
	4	7	35	32			X		X		X		A
	5	6	32	26	X	X	X		X		X		A
	6	5	32	26	X	X	X		X		X		A
	7	4	32	26	X	X	X		X		X		A
	8	3	32	26	X	X	X		X		X		A
	9	2	28	6	X	X	X		X		X		A
	10	1	28	6	X	X	X		X		X		A
12	1	11	31	17		X			X		X		A
	2	10	31	17		X			X		X		A
	3	9	31	17		X			X		X		A
	4	8	31	17	X		X		X		X		A
	5	7	31	17	X		X		X		X		A
	6	6	31	17	X		X		X		X		A
	7	5	31	17	X	X	X		X		X		A
	8	4	31	17	X	X	X		X		X		A
	9	3	31	17	X	X	X		X		X		A
	10	2	28	17	X	X	X		X		X		A
	11	1	28	17	X	X	X		X		X		A
13	1	12	29	15		X			X		X		A
	2	11	29	15		X			X		X		A
	3	10	29	15			X		X		X		A

TABLE F (Cont)

CABLE LENGTH (KFT)			POTENTIOMETER SETTINGS		INDUCTANCE SETTINGS* L SCREW DOWN					R*	BOR*	C*	4066H SCREW DOWN
OVERALL	26 GA	24 GA	R1	R2	.05	.1	.2	.4	.8				
13 (Cont)	4	9	29	15			X		X		X		A
	5	8	29	15	X		X		X		X		A
	6	7	29	15	X		X		X		X		A
	7	6	29	15	X		X		X		X		A
	8	5	29	15		X	X		X		X		A
	9	4	29	15		X	X		X		X		A
	10	3	29	15	X	X	X		X		X		A
	11	2	29	15	X	X	X		X		X		A
	12	1	23	0		X	X		X		X		A
14	1	13	28	10	X				X		X		A
	2	12	28	10	X				X		X		A
	3	11	28	10	X				X		X		A
	4	10	28	10	X	X			X		X		A
	5	9	28	10	X	X			X		X		A
	6	8	28	10	X		X		X		X		A
	7	7	28	10	X		X		X		X		A
	8	6	28	10	X		X		X		X		A
	9	5	26	0		X	X		X		X		A
	10	4	26	0		X	X		X		X		A
	11	3	26	0		X	X		X		X		A
	12	2	24	0		X	X		X		X		A
	13	1	24	0		X	X		X		X		A
15	1	14	27	16		X	X	X			X		A
	2	13	27	16		X	X	X			X		A
	3	12	26	0	X				X		X		A
	4	11	26	0	X				X		X		A
	5	10	28	0	X	X			X		X		A
	6	9	28	0	X	X			X		X		A
	7	8	26	0			X		X		X		A
	8	7	26	0			X		X		X		A
	9	6	26	0	X		X		X		X		A
	10	5	26	0	X		X		X		X		A

TABLE F (Cont)

CABLE LENGTH (KFT)			POTENTIOMETER SETTINGS		INDUCTANCE SETTINGS* L SCREW DOWN					R*	BOR*	C*	4066H SCREW DOWN
OVERALL	26 GA	22 GA	R1	R2	.05	.1	.2	.4	.8				
15 (Cont)	11	4	25	0	X		X		X		X		A
	12	3	24	0	X		X		X		X		A
	13	2	24	0	X		X		X		X		A
	14	1	24	0	X		X		X		X		A

* X indicates screws down.

TABLE G

830E NETWORK PRESCRIPTION SETTINGS FOR MIXED 24-22 GAUGE CABLE WITH
24 GAUGE NEAREST THE REPEATER AND WITHOUT BRIDGED TAPS

CABLE LENGTH (KFT)			POTENTIOMETER SETTINGS		INDUCTANCE SETTINGS* L SCREW DOWN					R*	BOR*	C*	4066H SCREW DOWN
OVERALL	24 GA	22 GA	R1	R2	.05	.1	.2	.4	.8				
8	1	7	37	31				X	X	X			B
	2	6	38	38				X	X	X			B
	3	5	38	45	X	X	X		X		X		B
	4	4	39	51	X	X	X		X		X		B
	5	3	39	59	X	X	X		X		X		B
	6	2	40	66		X	X		X		X		B
	7	1	40	73		X	X		X		X		B
9	1	8	37	30				X	X	X			B
	2	7	37	37				X	X	X			B
	3	6	38	43	X	X	X		X	X			B
	4	5	38	49	X	X	X		X		X		B
	5	4	39	55	X	X	X		X		X		B
	6	3	39	61	X	X	X		X		X		B
	7	2	40	67		X	X		X		X		B
	8	1	40	74		X	X		X		X		B
10	1	9	33	10		X	X		X	X			B
	2	8	33	13		X	X		X	X			B
	3	7	32	17		X	X		X	X			B
	4	6	32	20	X		X		X		X		A
	5	5	31	22	X		X		X		X		A
	6	4	31	25	X		X		X		X		A
	7	3	31	28			X		X		X		A
	8	2	30	32			X		X		X		A
	9	1	30	28			X		X		X		A
11	1	10	31	11	X		X		X	X			B
	2	9	31	14	X		X		X	X			B
	3	8	31	16	X		X		X		X		B
	4	7	31	19	X		X		X		X		A
	5	6	31	22	X		X		X		X		A
	6	5	30	24			X		X		X		A
	7	4	30	27			X		X		X		A

TABLE G (Cont)

CABLE LENGTH (KFT)			POTENTIOMETER SETTINGS		INDUCTANCE SETTINGS* L SCREW DOWN					R*	BOR*	C*	4066H SCREW DOWN
OVERALL	24 GA	22 GA	R1	R2	.05	.1	.2	.4	.8				
11 (Cont)	8	3	30	30			X		X		X		A
	9	2	30	32			X		X		X		A
	10	1	30	35			X		X		X		A
12	1	11	31	11	X		X		X		X		B
	2	10	31	13	X		X		X		X		A
	3	9	31	16	X		X		X		X		A
	4	8	31	18	X		X		X		X		A
	5	7	31	21	X		X		X		X		A
	6	6	30	23			X		X		X		A
	7	5	30	25			X		X		X		A
	8	4	30	28			X		X		X		A
	9	3	30	30			X		X		X		A
	10	2	30	33			X		X		X		A
	11	1	30	35			X		X		X		A
13	1	12	30	46	X	X	X	X			X		A
	2	11	30	44	X	X	X	X			X		A
	3	10	29	42					X		X		A
	4	9	29	40					X		X		A
	5	8	29	38					X		X		A
	6	7	28	36	X				X		X		A
	7	6	28	36	X	X			X		X		A
	8	5	27	34		X			X		X		A
	9	4	27	32		X			X		X		A
	10	3	27	30		X			X		X		A
	11	2	26	28	X	X			X		X		A
	12	1	26	26	X	X			X		X		A
14	1	13	27	36		X	X	X			X		A
	2	12	27	34		X	X	X			X		A
	3	11	27	33	X	X	X	X			X		A
	4	10	27	32	X	X	X	X			X		A
	5	9	27	31	X				X		X		A
	6	8	27	30	X				X		X		A

TABLE G (Cont)

CABLE LENGTH (KFT)			POTENTIOMETER SETTINGS		INDUCTANCE SETTINGS* L SCREW DOWN					R*	BOR*	C*	4066H SCREW DOWN
OVERALL	24 GA	22 GA	R1	R2	.05	.1	.2	.4	.8				
14 (Cont)	7	7	26	30	X				X		X		A
	8	6	26	30	X				X		X		A
	9	5	26	29	X				X		X		A
	10	4	26	28		X			X		X		A
	11	3	26	27		X			X		X		A
	12	2	26	26	X	X			X		X		A
	13	1	26	24	X	X			X		X		A
15	1	14	27	34		X	X	X			X		A
	2	13	27	33		X	X	X			X		A
	3	12	27	31		X	X	X			X		A
	4	11	26	29	X	X	X	X			X		A
	5	10	26	28	X	X	X	X			X		A
	6	9	26	26	X	X	X	X			X		A
	7	8	26	24					X		X		A
	8	7	25	24					X		X		A
	9	6	25	22	X				X		X		A
	10	5	25	20	X				X		X		A
	11	4	25	19	X				X		X		A
	12	3	24	17		X			X		X		A
	13	2	24	15		X			X		X		A
	14	1	24	14		X			X		X		A
16	1	15	24	26	X		X	X			X		A
	2	14	24	24	X		X	X			X		A
	3	13	24	23		X	X	X			X		A
	4	12	24	22		X	X	X			X		A
	5	11	24	21		X	X	X			X		A
	6	10	24	20	X	X	X	X			X		A
	7	9	24	19	X	X	X	X			X		A
	8	8	24	19					X		X		A
	9	7	24	19					X		X		A
	10	6	24	18					X		X		A
	11	5	24	17	X				X		X		A

TABLE G (Cont)

CABLE LENGTH (KFT)			POTENTIOMETER SETTINGS		INDUCTANCE SETTINGS* L SCREW DOWN					R*	BOR*	C*	4066H SCREW DOWN
OVERALL	24 GA	22 GA	R1	R2	.05	.1	.2	.4	.8				
16 (Cont)	12	4	24	16	X				X		X		A
	13	3	24	15	X				X		X		A
	14	2	24	14		X			X		X		A
	15	1	24	12		X			X		X		A
17	1	16	22	19			X	X			X		A
	2	15	24	8		X	X	X			X		A
	3	14	24	8		X	X	X			X		A
	4	13	24	8		X	X	X			X		A
	5	12	24	8		X	X	X			X		A
	6	11	24	8		X	X	X			X		A
	7	10	24	8		X	X	X			X		A
	8	9	23	5					X		X		A
	9	8	23	5					X		X		A
	10	7	23	5					X		X		A
	11	6	22	4					X		X		A
	12	5	22	4					X		X		A
	13	4	22	4					X		X		A
	14	3	22	0					X		X		A
	15	2	22	0					X		X		A
	16	1	22	0					X		X		A
18	1	17	22	19			X	X			X		A
	2	16	23	0			X	X			X		A
	3	15	23	0			X	X			X		A
	4	14	23	0			X	X			X		A
	5	13	23	0			X	X			X		A
	6	12	23	0	X		X	X			X		A
	7	11	23	0	X		X	X			X		A
	8	10	23	0	X		X	X			X		A
	9	9	23	0		X	X	X			X		A
	10	8	23	0		X	X	X			X		A
	11	7	23	0		X	X	X			X		A
	12	6	22	0	X	X	X	X			X		A

TABLE G (Cont)

CABLE LENGTH (KFT)			POTENTIOMETER SETTINGS		INDUCTANCE SETTINGS* L SCREW DOWN					R*	BOR*	C*	4066H SCREW DOWN
OVERALL	24 GA	22 GA	R1	R2	.05	.1	.2	.4	.8				
18 (Cont)	13	5	22	0	X	X	X	X			X		A
	14	4	22	0	X	X	X	X			X		A
	15	3	22	0	X	X	X	X			X		A
	16	2	22	0	X	X	X	X			X		A
	17	1	22	0	X	X	X	X			X		A

* X indicates screws down.

TABLE H

ADJUSTMENTS OF 4066H NETWORK

RANGE OF DIRECT CURRENT SUPPLIED TO 500-TYPE TELEPHONE SET WITH HANDSET OFF THE CRADLE (MILLIAMPERES)	SCREW SWITCH TO BE CLOSED (TURNED IN); ALL OTHERS TO BE OPEN (TURNED OUT)
36 or less	A
37-50	B
51-61	C
62 or more	D

Note: Only one adjusting screw should be in the turned-in position for any of the dc ranges of current supplied to the 500-type set being simulated by the network. All others should be turned out two complete turns.