

## SIGNALING RANGE EXTENDER (SRE)

### DESCRIPTION AND OPERATION

	CONTENTS	PAGE
1.	GENERAL . . . . .	1
2.	FUNCTIONS . . . . .	1
3.	CIRCUIT OPERATION . . . . .	2
4.	MAINTENANCE AND TEST . . . . .	4

#### 1. GENERAL

**1.01** The signaling range extender (SRE) (NS-02517-01) is designed for the extension of central office coin line loop resistance limits to 2400 ohms (step-by-step coin first to 2100 ohms) by adding a voltage in series with the central office leads. It improves switchhook supervision, dialing, and station transmitter performance by increasing the office and station current on long loops. The SRE does not provide voice-frequency (VF) gain, but it is compatible with the E6 repeater.

**1.02** The SRE (Fig. 1) is a self-contained unit utilizing plug-in, solid-state circuitry to provide range extension for a maximum of ten lines. The unit shelf is mounted on a standard 23-inch relay rack and requires a mounting space 4 inches high by 10 inches deep. Figure 2 is a simplified application schematic of the SRE on a coin station line.

**1.03** The SRE basic unit is equipped with:

- (a) An inverter circuit pack (CP 1)
- (b) An alarm and transfer circuit pack (CP 2)
- (c) Plug-in mountings for ten range extender circuit packs (CP 3).

**1.04** The SRE supplemental unit is identical to the basic unit except that it is not equipped with an inverter (CP 1). Figure 3 displays typical shelf arrangements that provide automatic transfer and supplementary unit operation.

**1.05** Local tests of SRE equipped lines may be made without removing the range extender from the loop being tested. Section 662-510-500 contains local testing procedures for leakage, foreign potential, and ballistic tests of customer lines equipped with the SRE.

**1.06** The SRE does not include a repeat coil in the signaling and transmission path. Any longitudinal current induced in the cable pair passes through the SRE and into the office circuit to which it is connected. Connecting circuit limitations, which are specified to assure pulsing performance, should be observed. For low noise transmission performance, the voltage measured across a 500-ohm resistor connected between ground and the cable pair (tip and ring connected) should be less than 5 volts rms.

#### 2. FUNCTIONS

**2.01** The functions of the SRE are to provide:

- (a) Additional line voltage of 24 volts, limited at 70 milliamperes with loop sensing to follow CO battery reversals
- (b) Ring trip assist (approximately 8 milliamperes) when ringing is superimposed on  $\pm 48$  volts
- (c) Lamp indication and office alarm signals for inverter failure or range extender circuit pack fuse failure
- (d) Increased signaling and transmitter current.

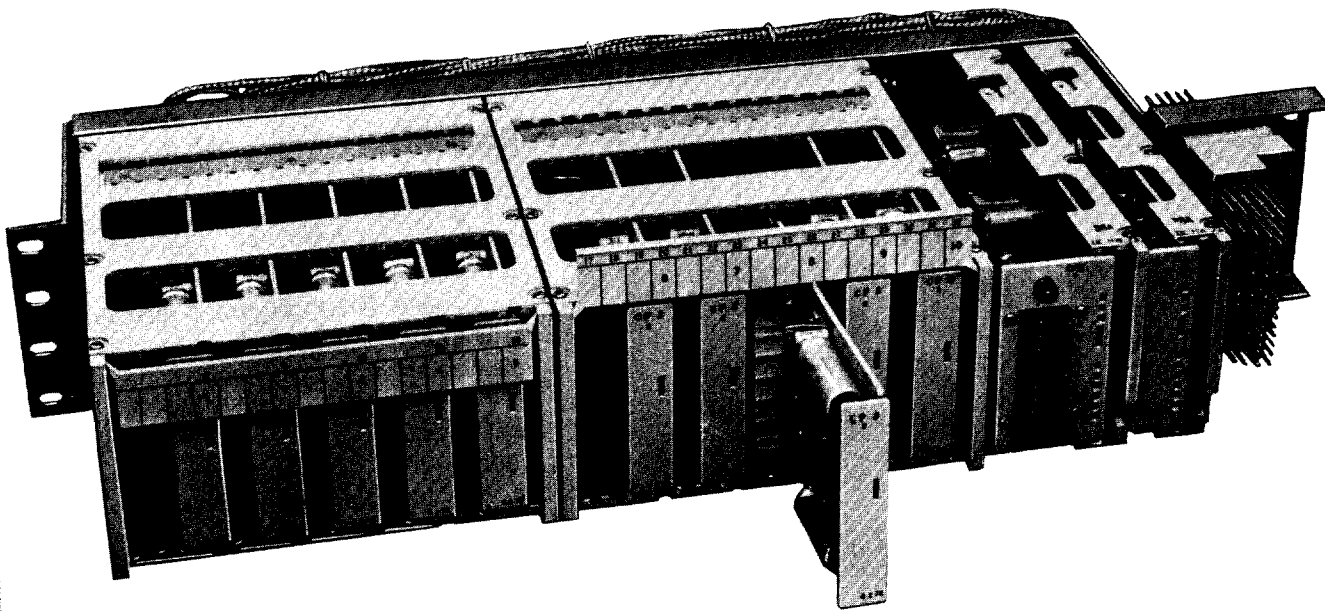

Fig. 1—Signaling Range Extender

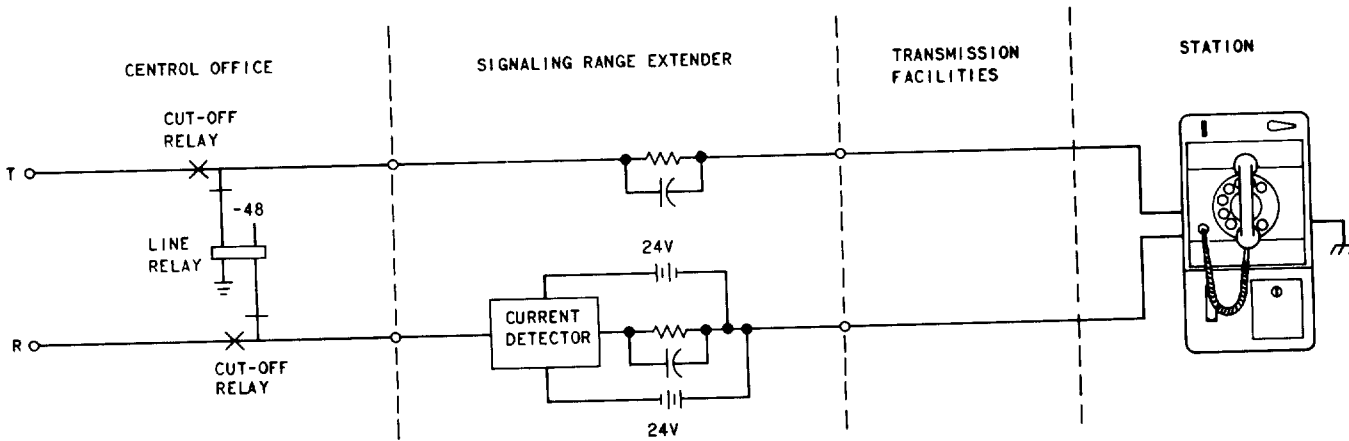

Fig. 2—SRE Application Schematic on Coin Station Line

### 3. CIRCUIT OPERATION

**3.01** The SRE requires fused -48 Vdc central office battery, which is fed into a dc-ac inverter. The inverter produces a 10-kHz square wave output with a peak-to-peak value equal to the central office battery input voltage. The 10-kHz output is coupled through the alarm and transfer circuit to each range extender, which in turn rectifies and filters the voltage for application to the line.

**3.02** The alarm and transfer circuit provides an alarm lamp indication and office alarm signals for inverter or individual range extender failure. In the event of inverter failure, the circuit also provides automatic transfer to an optional alternate inverter.

**3.03** When the subscriber is on-hook, the loop is open, no loop current flows, and the range extender is idle. When off-hook, the loop is closed and current is sensed by the range extender,

EQPT LOC	4	7	10	13	16	20	23	26	29	32	33	34	
BASIC	CP 3	CP 3	CP 3	CP 3	CP 3	CP 3	CP 3	CP 3	CP 3	CP 3	CP 2	CP 1	(Z)
BASIC	CP 3	CP 3	CP 3	CP 3	CP 3	CP 3	X	X	X	X	CP 2	CP 1	(R)

16 Lines Served

Two basic SRE shelves arranged for automatic transfer, one fully equipped and one partially equipped.

EQPT LOC	4	7	10	13	16	20	23	26	29	32	33	34	
BASIC	CP 3	CP 3	CP 3	CP 3	CP 3	CP 3	CP 3	CP 3	CP 3	CP 3	CP 2	CP 1	(Z)
BASIC	CP 3	CP 3	CP 3	CP 3	CP 3	CP 3	CP 3	CP 3	CP 3	CP 3	CP 2	CP 1	(R)
SUPL	CP 3	CP 3	CP 3	CP 3	X	X	X	X	X	X	CP 2	X	(Q)

24 Lines Served

Two basic SRE shelves arranged for automatic transfer, one fully equipped and one provided with a supplementary unit partially equipped.

EQPT LOC	4	7	10	13	16	20	23	26	29	32	33	34	
BASIC	CP 3	CP 3	CP 3	CP 3	CP 3	CP 3	CP 3	CP 3	CP 3	CP 3	CP 2	CP 1	(Z)
SUPL	CP 3	CP 3	CP 3	CP 3	CP 3	CP 3	CP 3	CP 3	CP 3	CP 3	CP 2	X	(Q)
BASIC	CP 3	CP 3	CP 3	CP 3	CP 3	CP 3	CP 3	CP 3	CP 3	CP 3	CP 2	CP 1	(R)
BASIC	CP 3	CP 3	CP 3	CP 3	CP 3	CP 3	CP 3	CP 3	CP 3	CP 3	CP 2	CP 1	

40 Lines Served

Three basic SRE shelves, one provided with a supplementary unit and arranged for automatic transfer with another of the basic shelves. The bottom shelf is not arranged for automatic transfer or supplementary unit operation.

Fig. 3—Typical Shelf Arrangements

**SECTION 332-211-100**

producing a voltage in series with the line; the polarity depends upon the direction of current flow.

**3.04** The range extender will add to the off-hook loop current, will pass ringing during the ringing interval, and will assist operation of the office ring trip circuit during the ringing or silent interval.

**4. MAINTENANCE AND TEST**

**4.01** All connections for installation and optional operation are made on the equipment side of the shelf to conventional wire-wrap terminals.

**4.02** Special tools are not needed to install the SRE, and no adjustments are required. Trouble conditions are quickly cleared with the use of spare plug-in circuit packs. No maintenance requirements exist. The use of the 723B or 731A tools will facilitate the extraction of the circuit cards.

**4.03** A test extender unit (CP 6) is available for in-circuit monitoring and testing of circuit performance. Section 332-211-500 contains testing procedures with the test extender (NS-02517-01).

**4.04** A metallic bypass board (CP 5) is available to provide a metallic tip and ring connection through the SRE unit.