

**J99400A HOUSING ASSEMBLY**  
**INSTALLATION AND MAINTENANCE**  
**PACKAGED METALLIC FACILITY TERMINAL ASSEMBLIES**

CONTENTS	PAGE
1. GENERAL . . . . .	1
2. INSTALLATION—J99400A ASSEMBLY . . . . .	1
A. J99400A Housing Assembly Installation . . . . .	1
B. Front Covers—Installation and Removal . . . . .	5
C. J99400AA Power Supply/Frequency Generator—Installation and Removal . . . . .	5
3. MAINTENANCE—HOUSING ASSEMBLY OPERATION . . . . .	6
A. Front Panel Fuses and Controls—J99400AA Power Supply/Frequency Generator . . . . .	6
B. 928A Connector Replacement . . . . .	8
C. Power Cord Replacement . . . . .	9
4. TESTING ACCESS—J99400TA TEST EXTENDER . . . . .	10
5. REFERENCES . . . . .	10

**1. GENERAL**

**1.01** This section presents the installation and maintenance procedures for the J99400A Packaged Metallic Facility Terminal Assembly (PMFTA). Similar information is provided on the associated J99400AA Power Supply and Frequency Generator.

**1.02** When this section is reissued, the reason(s) for reissue will be given in this paragraph.

**1.03** The J99400A PMFTA Housing shown in Fig. 1 accommodates up to two Metallic Facility Terminal (MFT) plug-in units. The assembly also provides plug-in slots for both the J99400AA Power Supply/Frequency Generator and the ED-7C223 Group 1 Installation Data Sheet module. More detailed descriptive information on this assembly is given in Section 332-610-101.

**1.04** The installation data sheet (IDS) module (ED-7C223 Group 1) contains several plasticized cards in a 2-ring binder. These cards provide installation and maintenance information for the J99400A assembly. The charts referenced in the following paragraphs contain the same information as provided on the IDS cards.

**2. INSTALLATION—J99400A ASSEMBLY**

**2.01** The J99400A assembly is designed for simplicity of installation. The following paragraphs present the procedures for installing the main assembly and associated equipment.

**A. J99400A Housing Assembly Installation**

**2.02** Basic installation of the housing requires mounting it to a proper wall mount, making interface lead connections, and providing access to a 117 Vac power outlet. Figure 1 gives the basic layout of this assembly. Figure 2 is the lead plan of the 94-type interface connector. Chart 1 is the installation instructions.

**NOTICE**

Not for use or disclosure outside the  
Bell System except under written agreement

EMERGENCY EXTERNAL -48V BATTERY

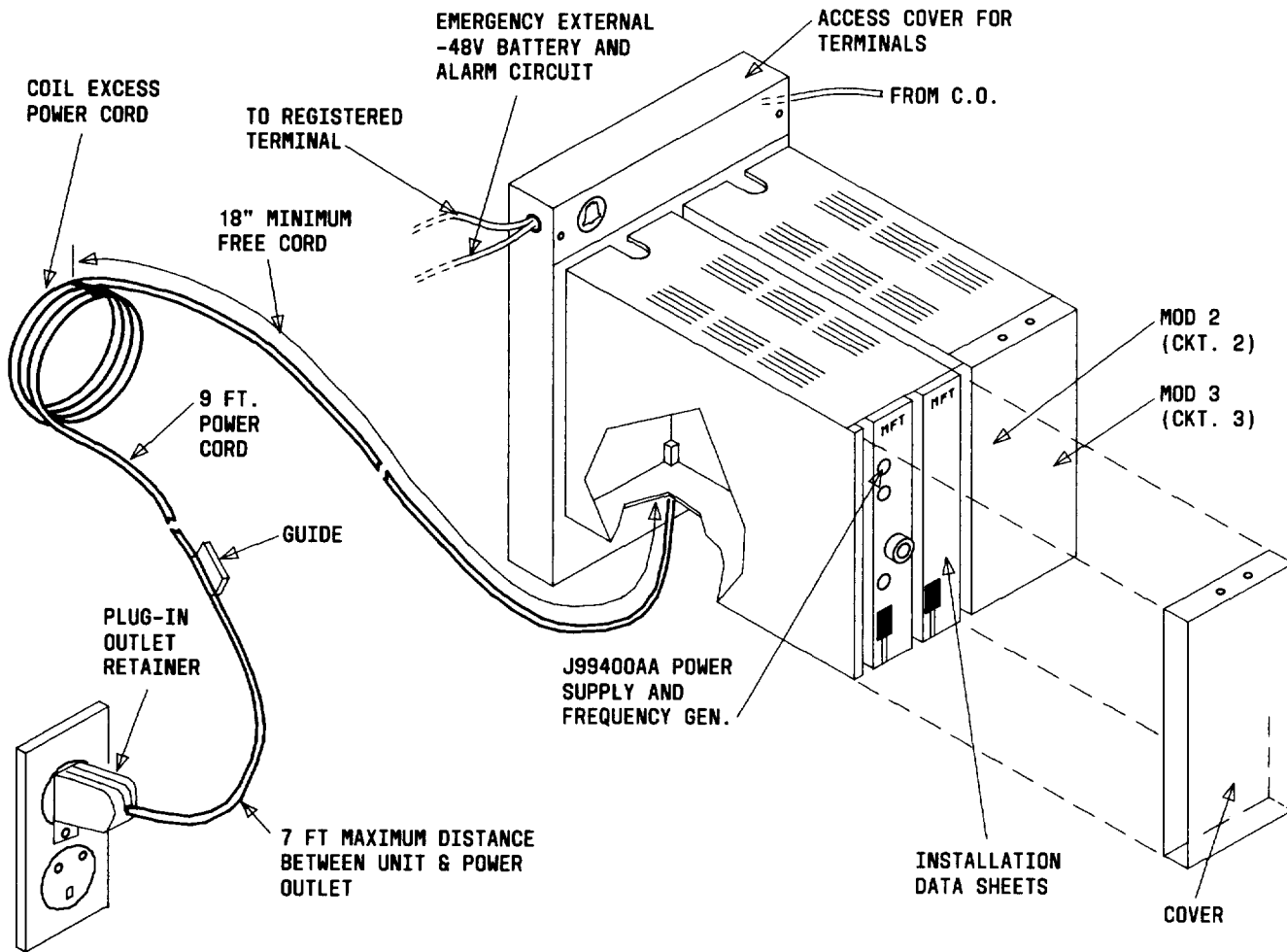

Fig. 1—Typical Layout of J99400A Housing Assembly

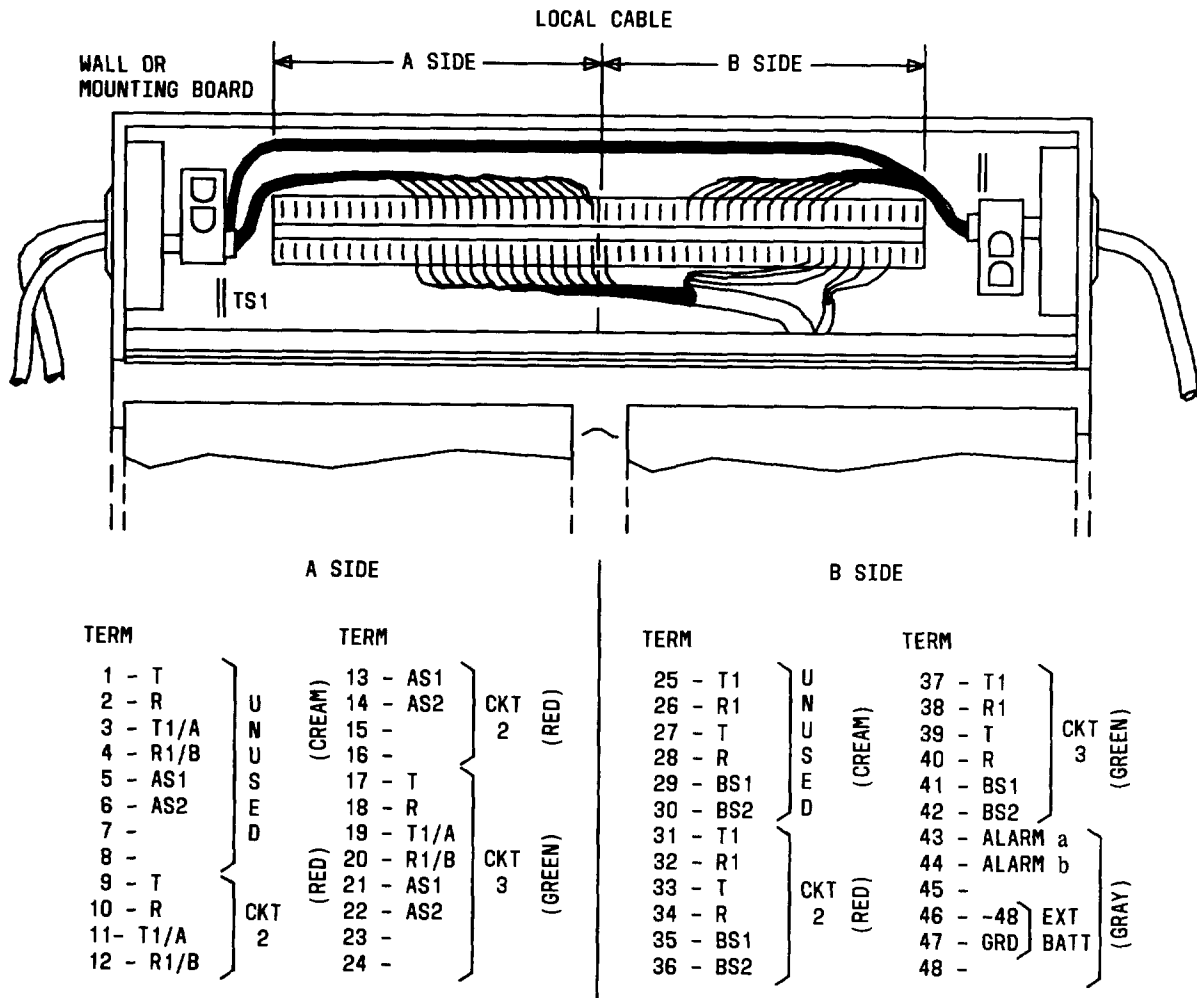

Fig. 2—Lead Designation and 94-Type Connector

2.03 The basic tools required are:

- R-4710 Impact Tool
- Standard Installer Tools

**CHART 1**

**J99400A HOUSING ASSEMBLY INSTALLATION**

**HOUSING ASSEMBLY INSTALLATION**

- 1 This J99400A Housing Assembly (Fig. 1) must be located within 7 feet of a 117 Vac outlet unless an extension cord is used. The ac power shall not be connected until installation is completed.
- 2 Mounting-plate, mounting-hole locations are accurately positioned on the supplied mounting-plate, mounting-hole template.

## CHART 1 (Contd)

- 3 Install three No. 10 screws for mounting the mounting plate to the wall. The top two screws should be adjusted for a distance of 1/8 inch between wall surface and screw shoulder. The bottom screw should be adjusted for 5/32 inch. The unit is then placed so that the bottom screwhead enters the keyhole mounting bracket and the unit is vertical and flush against the wall surface. The unit is then slid downward until the two upper screws hang on the upper slotted bracket. Tighten the bottom screw through the access hole located on the bottom-front of the mounting plate. Check the housing assembly to ensure that it is secured to the wall. The supplied hardware is for mounting to a wood wall surface. Other wall-mounting surfaces require additional hardware as specified below or its equivalent:
- (a) Sheetrock—hollow wall fasteners
  - (b) Metal—spring toggle bolts
  - (c) Masonry—lead anchors.
- 4 To access the local cable 94-type connector mounted at the top of the J99400A Housing Assembly mounting plate, remove the terminal access cover by (1) loosening the two screws on the top of the mounting plate, (2) slipping the cover equipped with keyhole mounting slots forward, and (3) lifting the cover upwards and over the screwheads.
- 5 Leads shall be installed in accordance with Fig. 2 using an R-4710 impact tool. Wiring sizes that may be terminated on the 94-type connector are 22, 24, and 26 gauge. Functional designations are marked beside each 94-type connection terminal (punching). All functional designations of a given circuit are marked on the same color background, with the adjacent circuit functional designation marked on a different color background. The 94-type connector color-coded backgrounds correspond to color-coded circuit designation decals located on the mounting plate under each circuit module position. Circuit function should be marked on the decal by the installer under the circuit designation. Registered terminal equipment wiring along with optional alarm and external battery wiring access the assembly from the left (facing), whereas, the central office wiring accesses the assembly from the right (facing). Secure strain relief clamp tightly around the cabling at each end of the 94-type connector (Fig. 2).
- 6 All leads shall be checked for proper operation before installation of MFT modules.
- 7 If external battery is required, 22-gauge wire shall be used with a current-limiting and overcurrent-breaking device installed at the battery. The maximum distance between the external battery and the J99400A Housing Assembly to which it is connected is 350 feet. The circuit shall be protected for 1.0 ampere. The -48V battery source shall be between -42 and -52 volts.
- 8 The ac power cord should be restrained by cable guides at approximately 1-foot intervals between unit and power receptacle. However, at least 18 inches of free cord extending from the bottom of the unit is required so that a test extender can be used for power supply maintenance. Any excess ac power cord should be coiled and restrained as shown in Fig. 1. The test extender, if supplied, is stored in a separate holder.

- 9 Plug in the 117 Vac power cord and install power plug retaining clamp to the 117 Vac outlet as shown in Fig. 1.
  - 10 A decal of the local cable 94-type connector functional terminal designations is provided on the inside of the mounting plate terminal access cover for use when the local cabling masks the color-coded functional terminal designations adjacent to the 94-type connector.
- 

#### **B. Front Covers—Installation and Removal**

**2.04** Chart 2 presents the procedure for installing and removing the two front cover plates. These covers provide protection for the plug-in modules. No special tools are required.

---

#### **CHART 2**

#### **FRONT COVERS—INSTALLATION AND REMOVAL**

---

##### **FRONT COVER INSTALLATION**

- 1 The two plastic housing front covers are attached by (1) locating the alignment pins located in the inside tops of the covers into the corresponding holes located in the tops of the plastic housings, (2) moving the covers downward, and (3) snapping the latches, located on the bottom of the covers, over the lip on the bottoms of the plastic housings.

##### **FRONT COVER REMOVAL**

- 2 To remove the front covers from the plastic housings, apply sufficient downward finger force on the cover latches to clear the housing lips and gently lift to disengage the cover alignment pins from the plastic housings.
- 

#### **C. J99400AA Power Supply/Frequency Generator— Installation and Removal**

**2.05** The J99400AA is a plug-in module which is installed in the left-hand slot of the J99400A assembly. Chart 3 presents the procedures for installing this module. Prior to its installation, the ac power cord must be installed according to the procedure. No special tools are required.

## CHART 3

J99400AA POWER SUPPLY  
FREQUENCY GENERATOR—INSTALLATION REMOVAL

## J99400AA POWER SUPPLY/FREQUENCY GENERATOR INSTALLATION

- 1 The procedure for installing the power supply/frequency generator into the left-hand (facing) plastic housing is as follows:
  - (a) Pull the 117 Vac power cord forward approximately 18 inches while guiding the power cord upwards through the power cord access opening in the bottom of the plastic housing.
  - (b) Plug the female end of the 117 Vac power cord into the 117 Vac receptacle located in the safety cover on the power supply/frequency generator printed wiring board as shown in Fig. 3.
  - (c) Position power cord down and around the bottoms of the two transformers mounted at the top of the printed wiring board, adjusting the power cord radius at the top of the connector so that it is just below the plastic card holder as shown in Fig. 3.
  - (d) Attach the cable clamp located on the rear uppermost transformer tightly around the power cord and engage the stud button through the closest strap hole (Fig. 3). Tuck excess strap through slot in clamp base.
  - (e) Insert power supply/frequency generator into the left-hand mounting position (facing), and push forward while applying a pulling force on the power cord at the point where it exits the access opening at the bottom of the plastic housing until the unit engages the plas-

## REMOVAL

- 2 Reverse the procedure stated in the power supply/frequency generator installation instructions to remove the power supply/frequency generator from the plastic housing.

## 3. MAINTENANCE—HOUSING ASSEMBLY OPERATION

3.03 When a SIG or TALK fuse on the front panel requires replacement, a 319B replacement tool is required.

3.01 There are no scheduled maintenance requirements for the J99400A assembly other than what would be considered routine for equipment of this type. However, the following charts give the procedures that should be followed in the event equipment failure should occur. Only the more likely failures are covered in the following charts.

**Note:** Spare fuses are located inside the J99400A Housing Assembly terminal access cover.

## A. Front Panel Fuses and Controls—J99400AA Power Supply/Frequency Generator

3.02 Chart 4 gives information for the operation and replacement of the various devices on the front panel of the J99400AA plug-in unit.

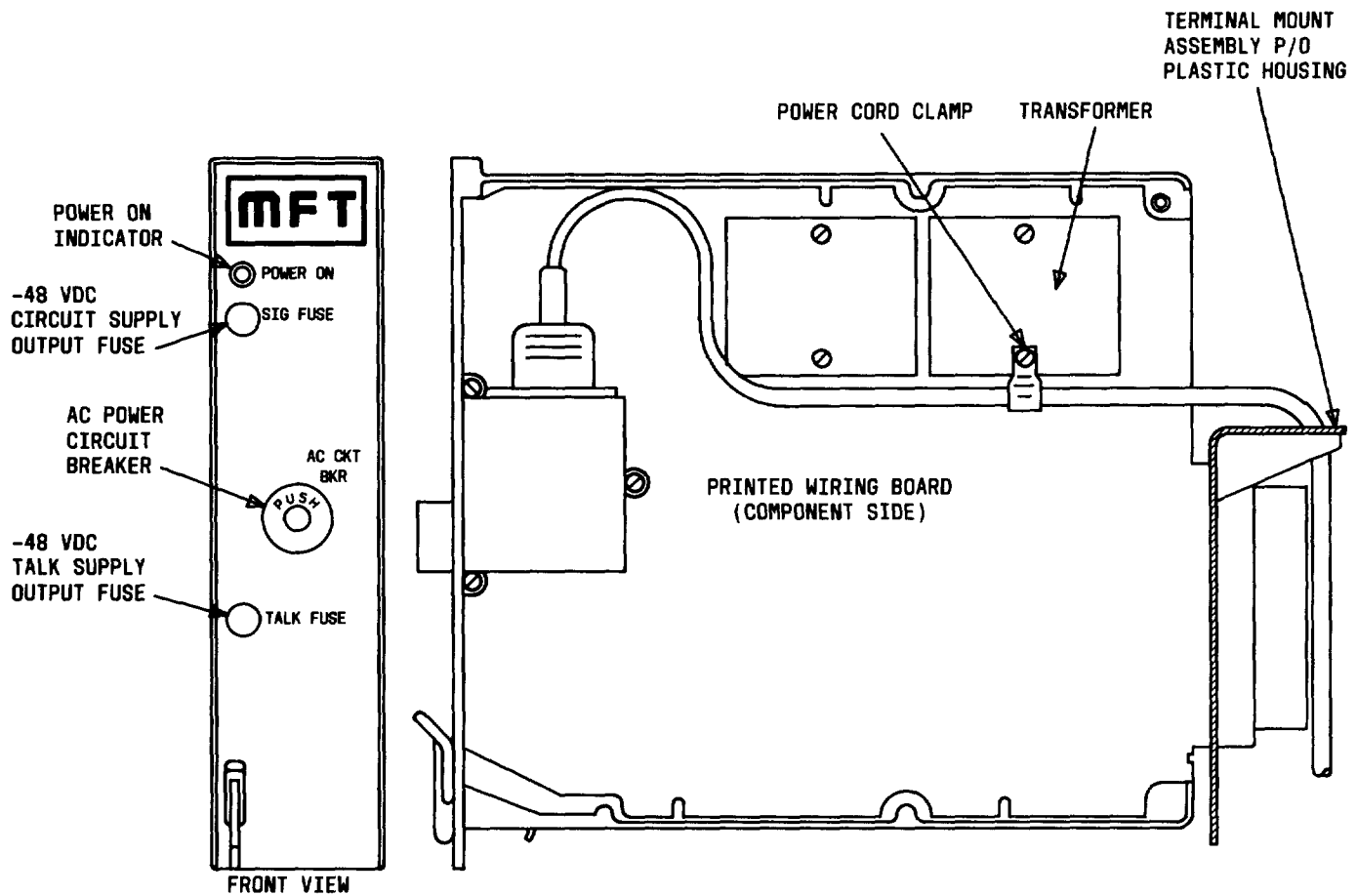

Fig. 3—J99400AA Power Supply/Frequency Generator and Power Cord

## CHART 4

FRONT PANEL FUSES AND CONTROLS—J99400AA POWER SUPPLY  
FREQUENCY GENERATOR

## HOUSING ASSEMBLY OPERATION—FRONT PANEL CONTROLS

- 1 The green power-on light should be illuminated if both the dc outputs and the 20-Hz frequency generator are functioning. Operation of the overvoltage protection circuit will cause the green power-on indicator to go out. If removing and reapplying ac power does not restore the power-on indicator, the power supply is faulty and requires replacement.
- 2 The red-fuse light will come on when a fuse blows. A WE 319B lamp cap remover is required for removing the 0.5 AMP fuses. Repeated blowing of these fuses indicates a faulty module 1 or module 2. Spare fuses are located on the mounting plate terminal access cover.
- 3 If the circuit breaker trips, the center button with white sides will extend. The circuit breaker is reset by pushing this center button. Continued tripping of the circuit breaker indicates a faulty power supply and requires replacement.

---

CHART 4 (Contd)

---

**SPARE FUSE STORAGE**

- 4 Spare fuses for the J99400AA power supply/frequency generator are located on the J99400A Housing Assembly terminal access cover (Fig. 1).
- 

**B. 928A Connector Replacement**

**3.04** In certain situations, the MFT modules are frequently changed in a housing. Because of this, the plug-in connector may become defective. Chart 5 gives the procedure for replacement of the connector.

---

CHART 5

**928A CONNECTOR REPLACEMENT**

---

**928A CONNECTOR REPLACEMENT**

- 1 The removal of a plastic housing connector can be achieved by the following steps:
- (a) Remove 117 Vac plug from outlet.
  - (b) Remove plug-in module from plastic housing connector being replaced. (If power supply must be removed/installed, follow the power supply/frequency generator installation and removal instructions.)
  - (c) Loosen screw through access hole at bottom center of the mounting plate.
  - (d) Slide housing assembly upward and forward to remove assembly from the wall.
  - (e) Remove all wire-wrap connections on the connector being removed. Access connector terminals through cutout access holes at the back of the mounting plate.
  - (f) Remove screw at bottom of connector being removed. A screwdriver access hole is provided in the mounting plate over each connector mounting screw.
  - (g) Slip connector downward and out through the access hole in the mounting plate.
- 2 To install a replacement connector in the plastic housings, reverse the 928A connector replacement instructions. Be sure to reinstall the 117 Vac plug retainer on the power receptacle as shown in Fig. 1.
-



**C. Power Cord Replacement**

**3.05** Another device that may require replacement over the years is the power cord. Chart 6 gives a detailed procedure for the replacement of this device.

---

**CHART 6****POWER CORD REPLACEMENT**

---

**POWER CORD REPLACEMENT**

- 1 To replace the 117 Vac power cord on the J99400A Housing Assembly requires the following steps:
    - (a) Remove 117 Vac plug from outlet.
    - (b) Remove power supply frequency generator and adjacent plug-in from the plastic housing. Follow the power supply/frequency generator removal instructions for power supply removal.
    - (c) Remove left-hand plastic housing (facing) from the mounting plate by (1) loosening the two screws located at the inside-back, top corners and the screw located at the inside-back, bottom-center of the plastic housing being removed and (2) slipping the plastic housing up and off the mounting plate.
    - (d) Remove old power cord and replace with new power cord. Route the power cord up through the rear of the plastic housing, through a cutout in the terminal mount assembly and into the housing cavity (Fig. 3).
    - (e) Reinstall plastic housing to mounting plate by (1) placing the plastic housing so that the screwhead on the mounting plate enters the keyhole on the back, bottom-center of the plastic housing, (2) placing the plastic housing vertical and flush to the mounting plate, (3) sliding the plastic housing downward until the two upper screws hang on the upper slotted brackets located on the upper rear corners of the plastic housing, (4) visually determining that the screws are engaging the mounting slots, (5) determining that the power cord is captured in access cutout at the bottom of the plastic housing, and (6) tightening the two screws located at the inside-back, top corners and the screw located at the inside-back, bottom-center of the plastic housing.
    - (f) Reinstall power supply/frequency generator using the power supply/frequency generator installation instruction and the adjacent plug-in into the plastic housing.
    - (g) Plug power cord into outlet.
-

**4. TESTING ACCESS—J99400TA TEST EXTENDER**

**4.01** A J99400TA Test Extender assembly (Fig. 4) facilitates the testing associated with all the MFT modules and may be ordered separately. This test extender provides for full extension of a powered MFT module outside the housing boundaries. The feature permits total access to adjustments on the MFT module under test as well as the adjustments on the test extender itself. A functional schematic decal of jack and switch connections is provided on the wiring side of the printed wiring board assembly. This functional schematic should simplify the using of the test extender. The test extender is intended for use with the J99400 Housing assemblies but can be used on any MFT shelf. Both front covers of the J99400A housing assembly should be removed when using this test extender.

**4.02** A test probe access hole is provided for each terminal on the 94-type insulation displacement connector.

**5. REFERENCES**

**5.01** The following references provide additional information on the J99400A Housing.

REFERENCE	TITLE
332-610-101	Description of the J99400A Housing Assembly
SD-7C093	PMFTA—J99400A
SD-73092	J99400AA Power Supply/ Frequency Generator
SD-7C094	J99400TA Test Extender
<b>5.02</b> The following general MFT documents provide information on equipment compatible with the J99400A Housing.	
REFERENCE	TITLE
332-910-100	(J99343)—General
332-910-180	MFT—General Applications

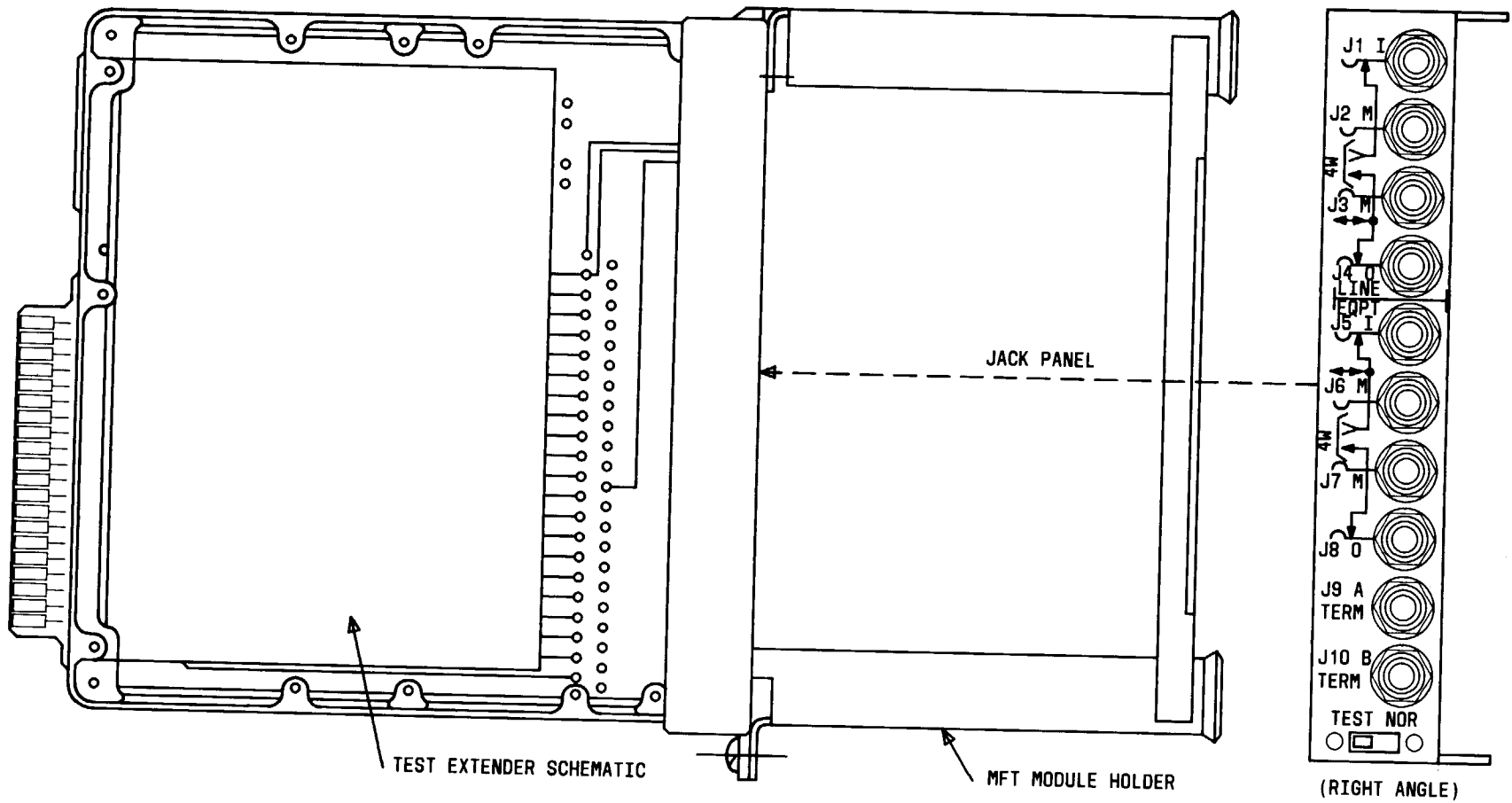

Fig. 4—J99400TA Test Extender