

BPT72 2/4-4 WIRE DATA INTERFACE UNIT
DESCRIPTION AND INSTALLATION
"OMNIPOINT" * NETWORK CHANNEL TERMINATING EQUIPMENT

CONTENTS	PAGE	CONTENTS	PAGE
1. GENERAL	1	4. Typical Applications of BPT72	11
2. UNIT DESCRIPTION	2	5. Gain and Equalizer Adjusting Arrangements	13
A. Unit Specifications	2		
B. Unit Impedance	2	Tables	
C. Maintenance Feature	2	A. BPT72 Unit Specifications	5
D. Sealing Current	2	B. BPT72 Lead Designations and Functions	8
E. Monitor Jacks	2	C. Equalizer Performance	9
F. Identification Leads	2	D. Typical BPT72 Attenuation Distortion	11
G. Unit Controls	2	E. Gain and Equalization Factors	12
H. Equalization	3		
I. Attenuation Distortion	3	1. GENERAL	
3. APPLICATION	3	1.01 This practice provides description, application, and installation information for the OMNIPOINT NCTE (Network Channel Terminating Equipment) BPT72 2/4-4 wire DIU (data interface unit). A general description of OMNIPOINT NCTE is given in AT&T Practice 332-620-100.	
4. INSTALLATION	3	1.02 When this practice is reissued, the reason(s) for reissue will be listed in this paragraph.	
A. Gain and Equalization	3	1.03 The BPT72 DIU is part of the OMNIPOINT NCTE family of customer premises equipment (both mountings and circuit packs) for voice-frequency special services, maintenance, and analog data services. This unit provides the same functions as the BPT62 DIU with an alternate industry standard lead plan.	
5. MAINTENANCE	4		
Figures			
1. Block Diagram of BPT72	7		
2. BPT72 Unit Controls and Faceplate	7		
3. Equalizer Performance Curves	10		

* Trademark of AT&T Technologies.

2. UNIT DESCRIPTION

2.01 The BPT72 is a switch selectable 2-4 or 4-4 wire terminal repeater with a maintenance loopback feature for use on private line voice-frequency data circuits. It provides -20 to +26.5 dB of gain in 0.1-dB steps in both directions of transmission. This unit also provides 0 to 15 dB of 2804-Hz post-equalization in 1-dB steps in the receive (from the network) direction.

2.02 This unit can be mounted in any 400-type mounting that conforms to the Regional Bell Operating Companies standard lead plan for data interface units and supplies -48 or ±12 volts dc power to the unit.

A. Unit Specifications

2.03 The BPT72 unit specifications are summarized in Table A. Figure 1 is a block diagram of the unit and Fig. 2 shows the unit controls and faceplate. Table B is a listing of the unit leads and their functions.

B. Unit Impedance

2.04 This unit provides a 600-ohm impedance to the customer equipment and a switch selectable 150-, 600-, or 1200-ohm impedance to the network facility. The 600- and 1200-ohm impedances are used to match nonloaded and loaded cable, respectively. The 150-ohm impedance is used to provide mismatch equalization on nonloaded cable.

C. Maintenance Feature

2.05 The maintenance feature is remotely activated by applying a 2713-Hz tone to the unit for at least 2 seconds. Upon removal of the tone, the maintenance feature activates, causing the unit to disconnect the customer equipment from the circuit and provide a loopback connection to the network facility. A switch selectable gain of 0, 8, or 16 dB is inserted in the loopback path to provide standard signal levels to the transmit (to the network) path. A BUSY indicator on the unit faceplate will light while the maintenance feature is activated. The maintenance feature can be deactivated either by applying a 2713-Hz tone to the unit for at least 1 second or by allowing the feature to automatically time out after 20 minutes.

2.06 In the 2-4 wire configuration, the maintenance feature internally terminates and tests the compromise canceler as part of the loopback connection.

2.07 The maintenance feature can be locally activated by connecting the MLB (manual loopback) lead (pin 1) to the MLBG (manual loopback return) lead (pin 19). The unit will remain in the loopback condition as long as the MLB and MLBG leads are connected together.

2.08 A contact opening is provided between the SI and SIR leads (formerly designated TEK5 and TEK6, respectively) when the maintenance feature is activated as a "maintenance busy" indication to the customer equipment.

D. Sealing Current

2.09 A sealing current option is provided on this unit. This option connects the SXR and SXT leads together to provide a return path for sealing current applied at the far end of the circuit. If the maintenance feature is activated while the sealing current option is selected, the sealing current path will be opened to allow use of the maintenance feature.

E. Monitor Jacks

2.10 Two 310-type monitor jacks, TRANS MON and REC MON, are located on the BPT72 faceplate. These jacks provide test access to the customer side of the unit.

F. Identification Leads

2.11 This unit contains two identification leads (ID1 and ID2) for use by the telephone company. These leads are available for insertion of a component on the printed wiring board to allow positive identification of a particular unit.

G. Unit Controls

2.12 **BUSY:** This indicator on the unit faceplate will light when the maintenance loopback feature is in use.

2.13 **48V·12V:** This switch is set according to the power arrangement provided at the mounting. Set the switch in the 48V position if -48 volts dc is

supplied to the unit or in the 12V position if ± 12 volts dc is supplied.

2.14 2W·4W: This switch selects the customer-side interface. Set the switch in the 2W position to provide a 2-wire customer interface or in the 4W position to provide a 4-wire customer interface.

2.15 600·150·1200: This switch selects the network side output impedance. Set the switch in the 600 position to match nonloaded cable or in the 1200 position to match loaded cable. Set the switch in the 150 position to provide mismatch equalization.

2.16 SC: This option provides a sealing current return path when the switch is in the ON position.

2.17 0·8·16: This switch selects the amount of gain provided in the loopback path. Set the switch in the 0, 8, or 16 position to provide 0, 8, or 16 dB of loopback gain.

2.18 TRANS GAIN and REC GAIN: The TRANS GAIN and REC GAIN switches (.1, .2, .4, .8, 1, 2, 4, 8, 10, and -20) control -20 to +26.5 dB of gain in 0.1-dB steps in the transmit and receive directions, respectively. Set the switches so the sum of the switches in the ON position equals the desired gain or loss.

Note: The -20 switch provides 20 dB of loss. For example, if 8 dB of loss is required, set the -20, 10, and 2 switches in the ON position.

2.19 REC EQ: These switches (1, 2, 4, and 8) control 0 to 15 dB of post-equalization in 1-dB steps in the receive (from the network) direction. Set the switches so the sum of the switches in the ON position equals the desired equalization.

H. Equalization

2.20 The BPT72 provides 0 to 15 dB of slope equalization in 1-dB steps in the receive (from the network) direction. For ease of equalizer adjustment, the markings on the EQ switches indicate the amount of 2804-Hz equalization supplied when the switches are in the ON position. For example, if 3 dB of 2804-Hz equalization is required, set switches 1 and 2 in the ON position. Equalizer performance is shown in Table C and by the frequency response curves in Fig. 3.

2.21 The gain and equalizer settings are independent of each other. As shown in Fig. 3, the equalizer setting has little effect on the unit gain at 1 kHz while providing additional gain at 2800 Hz and introducing loss at 400 Hz.

2.22 When the 150-ohm output impedance option is used to provide mismatch equalization, the unit gain should be set using the unknown facility procedure of paragraphs 4.07 and 4.08 (disregard Steps 8 and 9 of the procedure which adjust the active equalizer).

I. Attenuation Distortion

2.23 This unit provides 0 to 15 dB of active post-equalization in the receive direction and flat frequency response in the transmit direction. Information on the receive channel equalization is provided in Table C and Fig. 3. Attenuation distortion values for the transmit channel are given in Table D.

3. APPLICATION

3.01 The BPT72 is a 2-4 or 4-4 wire terminal repeater for use on 4-wire voice-frequency private line data circuits. This unit can also be used as a 2-4 or 4-4 wire terminal repeater for voice-frequency special services applications. Typical applications of the unit are shown in Fig. 4.

4. INSTALLATION

4.01 The BPT72 can be installed in any 100-type mounting that uses a compatible lead plan for data interface units and provides either -48 or ± 12 volts dc power to the unit. Installation involves setting the unit controls and inserting the circuit pack in its mounting slot.

4.02 Set the unit controls as required for proper circuit operation. For convenience, the GAIN and EQ switch markings indicate the amount of gain and equalization supplied when the switches are placed in the ON position. The following paragraphs provide information on setting the GAIN and EQ switches.

A. Gain and Equalization

4.03 The gain and equalization to be provided can be determined by two methods. One method is

used when the facility length and gauge are known. The other method is used when the facility length and gauge are not known, if 150-ohm mismatch equalization is provided, or if the circuit fails to meet transmission requirements using the known facility method.

Known Facility

4.04 When the length and gauge of the facility are known, gain and equalization values can be obtained from the WORD (work order record and details) document, the CLR (circuit layout record) card, or by using the factors in Table E.

4.05 Table E contains multiplication factors that can be used to calculate the gain and equalization required. For mixed-gauge cables, the sum of the values calculated for each gauge will equal the required gain.

4.06 For nonloaded cable equalization settings, multiply the sum of the cable lengths, in kilofeet, by the equalization factor (0.25). If values between two available switch settings are obtained, use the lower value setting.

Example: Fifteen (15) kft of nonloaded cable has a calculated equalization value of 3.75 dB ($15 \text{ kft} \times 0.25 = 3.75 \text{ dB}$). An EQ switch setting of 3 should be used (i.e., switches 1 and 2 in the ON position).

Unknown Facility

4.07 The following procedure is for use when the length and gauge of the facility are not known, if 150-ohm mismatch equalization is provided, or if transmission requirements are not met using the known facility procedure. Test equipment required for the following procedure includes a 43A test extender, or equivalent; a 600-ohm oscillator; and a 600-ohm detector. Equipment connections for this procedure are shown in Fig. 5.

Note 1: This procedure can be performed without a test extender by using the TRANS MON and REC MON jacks on the unit faceplate if the customer equipment is not connected to the circuit.

Note 2: If 150-ohm mismatch equalization is provided, disregard Steps 8 and 9, which adjust the active equalizer.

4.08 Set the GAIN and EQ switches as follows:

- (1) Insert unit into test extender and insert test extender into mounting shelf.
- (2) Connect 600-ohm oscillator to customer-side T/R jack. Adjust oscillator to provide a 1004-Hz, 0-dBm signal.
- (3) Connect detector at far end of facility to measure tone.
- (4) Adjust TRANS GAIN switches to provide the desired level at far end.
- (5) Connect oscillator at far end of facility. Adjust oscillator to provide a 1004-Hz, 0-dBm signal.
- (6) Connect detector at customer side of unit to measure tone as follows:
 - (a) **Two-Wire Interface:** Remove oscillator from customer-side T/R jack and connect detector at customer-side T/R jack.
 - (b) **Four-Wire Interface:** Connect detector at customer-side T1/R1 jack.
- (7) Adjust REC GAIN switches to provide desired level at detector.
- (8) Adjust oscillator at far end of facility to provide a 2804-Hz, 0-dBm signal.
- (9) Adjust EQ switches to provide a 2804-Hz level equal to, or slightly less than, 1004-Hz level set in Step 7.
- (10) Remove test equipment and remove unit from test extender.
- (11) Insert unit into mounting shelf.

5. MAINTENANCE

5.01 This unit requires no routine maintenance. If a unit is faulty, replace it with a spare and send the defective unit to the nearest AT&T Service Center for repair.

TABLE A
BPT72 UNIT SPECIFICATIONS

<u>GENERAL</u>	
CLEI CODE	NCDI060AXX
DIMENSIONS (H, W, D)	5.60 × 1.45 × 5.90 Inches
WEIGHT	10.4 Ounces
TEMPERATURE	
Operating	0° to 50° Celsius
Storage	-40° to 66° Celsius
HUMIDITY	5 to 95 Percent Relative
<u>POWER INPUT REQUIREMENTS</u>	
VOLTAGE	
Nominal	±12 V dc or -48 V dc (PWB fused)
Range	±12 V dc ±5 Percent or -42.5 to -56.0 V dc
CURRENT DRAIN	
Typical	40 mA
Typical With Maintenance Feature Activated	80 mA
<u>TRANSMISSION</u>	
INTERFACE	2W-4W or 4W-4W
IMPEDANCE	
Customer Side	600 Ohms
Network Side	600/1200 Ohms (for nonloaded and loaded cable) 150 Ohms (for mismatch equalization of nonloaded cable)
GAIN/ATTENUATION	
Transmit	-20.0 to +26.5 dB (switch selectable in 0.1-dB steps)
Receive	-20.0 to +26.5 dB (switch selectable in 0.1-dB steps)
EQUALIZATION	
Receive (Post)	0 to 15 dB Slope (switch selectable in 1-dB steps)
RETURN LOSS	
Customer Side	
ERL	2-4 Wire Greater Than 20 dB
SRL	Greater Than 27 dB
Network Side	4-4 Wire Greater Than 29 dB
ELR	Greater Than 31 dB
SRL	Greater Than 31 dB Greater Than 32 dB (150, 600, or 1200 Ohms)
TRANSHYBRID LOSS	30 dB Minimum into 600 Ohms
LONGITUDINAL BALANCE	
(200 to 3000 Hz)	
Customer Side	Greater Than 60 dB
Network Side	Greater Than 60 dB

TABLE A (Contd)
BPT72 UNIT SPECIFICATIONS

<u>TRANSMISSION (Contd)</u>	
IDLE CHANNEL NOISE	Less Than 5 dBrnC
ENVELOPE DELAY DISTORTION	$\pm 100 \mu\text{sec}$ (200 to 4000 Hz referenced to 1 kHz)
PEAK-TO-AVERAGE RATIO (PAR)	98 or Greater
MAXIMUM SIGNAL LEVELS	
Input	+12 dBm
Output	+12 dBm
CROSSTALK	Greater Than 90 dB (between adjacent circuit packs)
<u>MAINTENANCE</u>	
TYPE	20-Minute Transmission Loopback With 0, +8, or +16 dB of Gain
TONE DETECTOR	2713 ± 7 Hz Tone, -30 dBm to 0 dBm (10 dB or greater signal-to-noise ratio)
REMOTE ACTIVATION	Activates After Removal of a 2-Second or Longer 2713 ± 7 Hz Tone
REMOTE DEACTIVATION	Deactivates After Receiving 2713 ± 7 Hz Tone for 1 Second or Will Time Out After 20 Minutes
LOCAL ACTIVATION	Activates When MLB and MLBG Leads (Pins 1 and 19) Are Connected Together. (Will remain activated until connec- tion is removed.)
CUSTOMER BUSY	SI and SIR Leads (formerly designated TEK5 and TEK6) Are Open

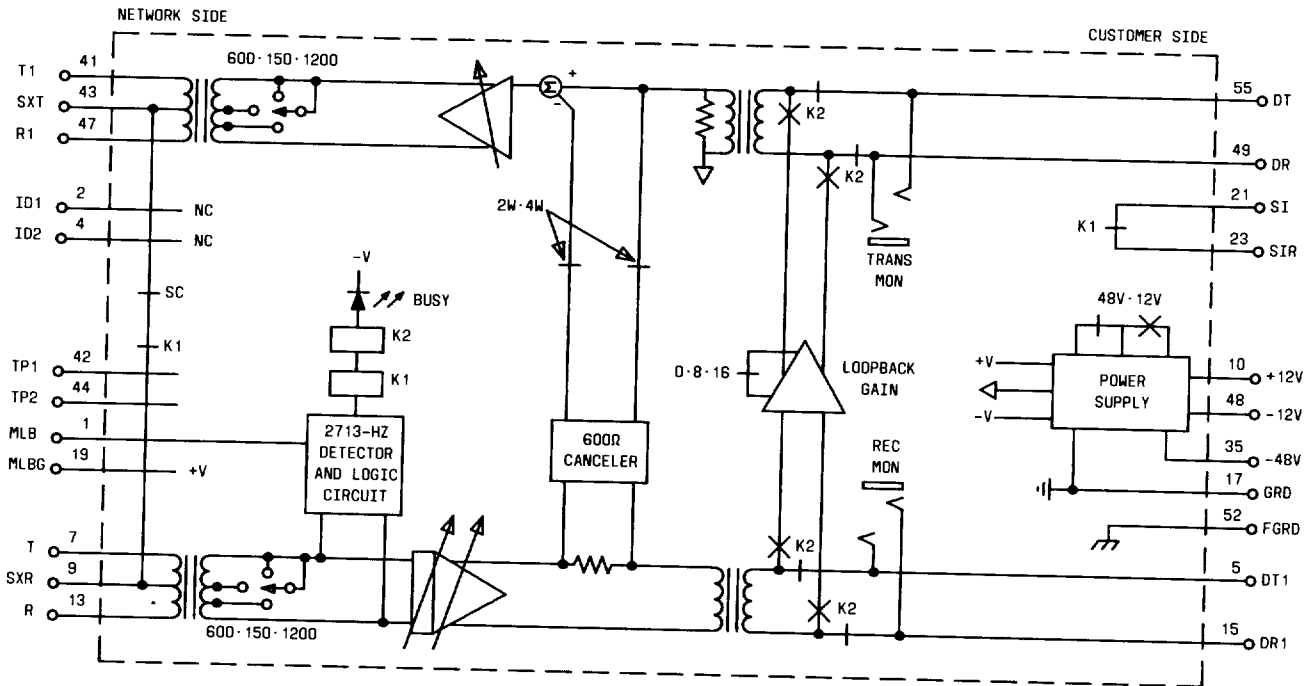

Fig. 1—Block Diagram of BPT72

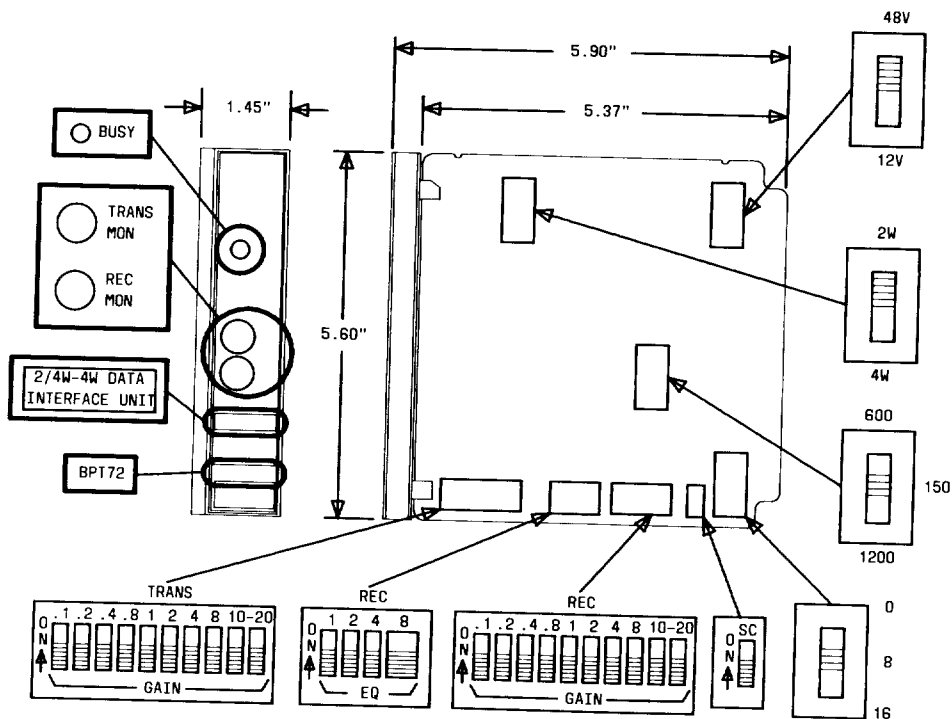

Fig. 2—BPT72 Unit Controls and Faceplate

TABLE B

BPT72 LEAD DESIGNATIONS AND FUNCTIONS

LEAD NO.	LEAD DESIG	FUNCTION
<u>NETWORK LEADS</u>		
41	T1	(Tip 1) Transmit Output Toward Network
47	R1	(Ring 1) Transmit Output Toward Network
43	SXT	Transmit Simplex Lead (Network Side)
7	T	(Tip) Receive Input From Network
13	R	(Ring) Receive Input From Network
9	SXR	Receive Simplex Lead (Network Side)
<u>CUSTOMER LEADS</u>		
55	DT	(Data Tip) Transmit/Receive Data Toward Customer (2W) or Transmitted Data Input From Customer (4W)
49	DR	(Data Ring) Transmit/Receive Data Toward Customer (2W) or Transmitted Data Input From Customer (4W)
5	DT1	(Data Tip 1) Received Data Output Toward Customer (4W)
15	DR1	(Data Ring 1) Received Data Output Toward Customer (4W)
21	SI	Status Indicator Toward Customer (formerly designated TEK5)
23	SIR	Status Indicator Return Toward Customer (formerly designated TEK6)
<u>POWER LEADS</u>		
10	+12V	+12V Battery Supply
48	-12V	-12V Battery Supply
17	GRD	+12V and -48V Battery Supply Ground
35	-48V	-48V Battery Supply
52	FGRD	Frame Ground
<u>MISCELLANEOUS LEADS</u>		
1	MLB	Manual Loopback
19	MLBG	Manual Loopback Return
2	ID1	Identification Lead 1
4	ID2	Identification Lead 2
42	TP1	Manufacturing Test Points
44	TP2	Manufacturing Test Points

TABLE C								
BPT72 EQUALIZER PERFORMANCE								
EQ SWITCH SETTING	FREQUENCY (Hz)							
	200	400	600	1000	1600	2000	2400	2800
0	-2.5	-0.8	-0.3	0.0	0.2	0.2	0.2	0.1
1	-2.8	-1.1	-0.6	-0.1	0.4	0.7	1.0	1.1
2	-3.2	-1.5	-0.9	-0.2	0.6	1.2	1.8	2.1
3	-3.6	-1.9	-1.2	-0.3	1.0	1.9	2.7	3.1
4	-4.1	-2.3	-1.5	-0.4	1.4	2.5	3.4	3.9
5	-4.8	-2.9	-2.0	-0.3	2.0	3.4	4.4	5.0
6	-5.7	-3.6	-2.4	-0.3	2.7	4.3	5.5	6.2
7	-7.0	-4.5	-2.8	0.1	3.7	5.5	6.8	7.5
8	-6.9	-5.4	-3.7	-0.2	3.9	5.7	7.1	8.2
9	-7.2	-5.7	-3.9	-0.3	4.1	6.2	7.9	9.2
10	-7.6	-6.1	-4.2	-0.4	4.3	6.8	8.7	10.1
11	-8.1	-6.5	-4.6	-1.4	4.7	7.5	9.6	11.2
12	-8.5	-6.9	-4.9	-0.6	5.0	8.0	10.3	11.9
13	-9.1	-7.5	-5.3	-0.7	5.6	8.9	11.4	13.1
14	-10.2	-8.2	-5.7	-0.4	6.4	9.8	12.4	14.2
15	-11.6	-9.1	-6.2	-0.9	7.4	11.0	13.7	15.5

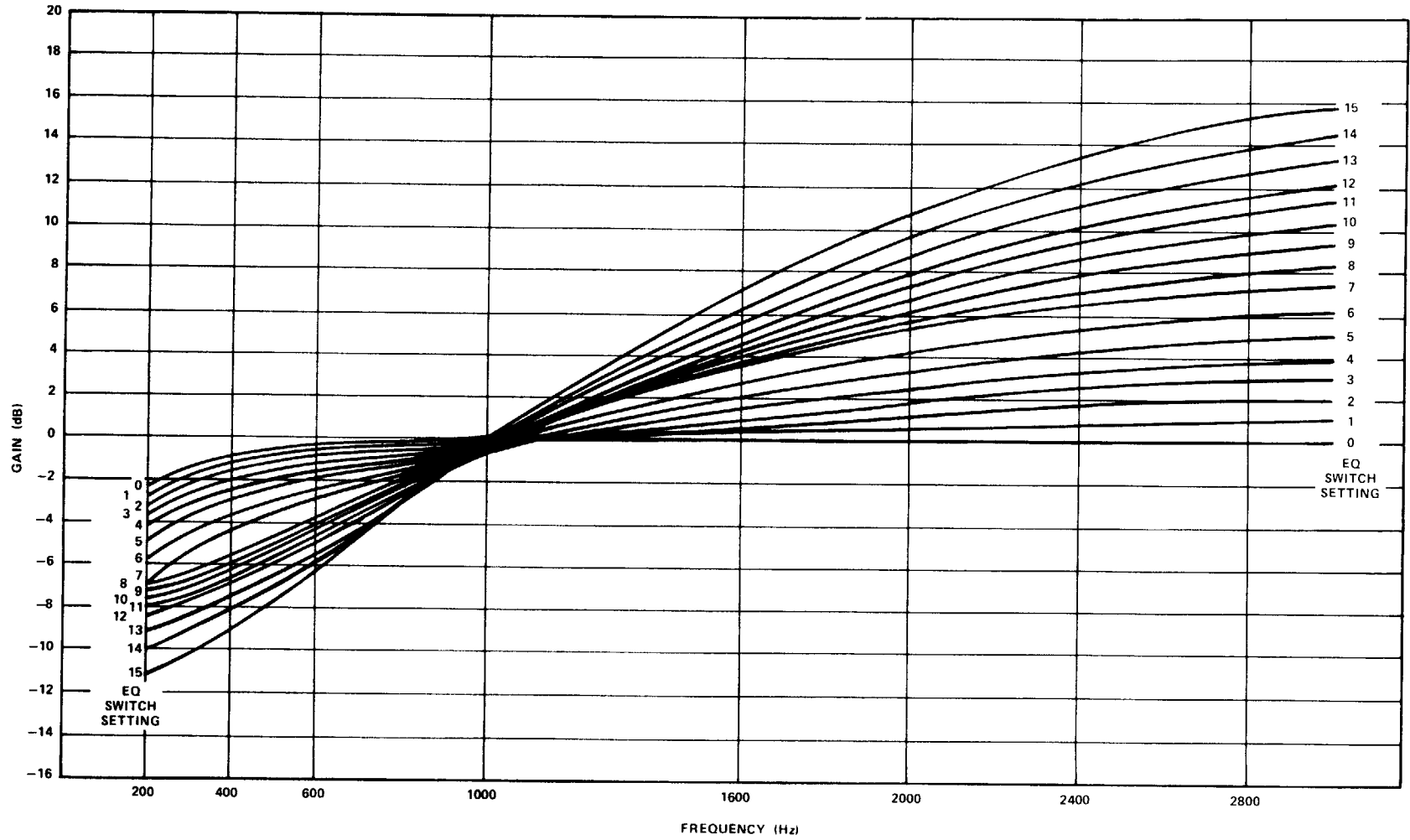
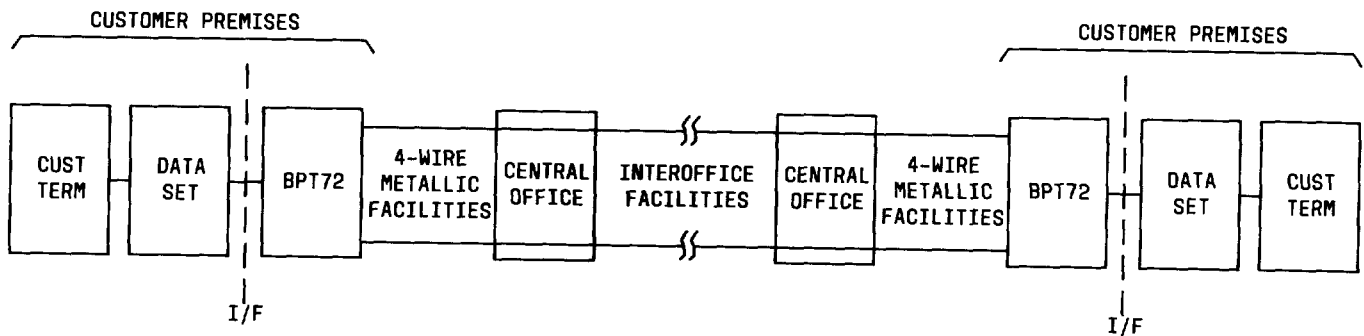
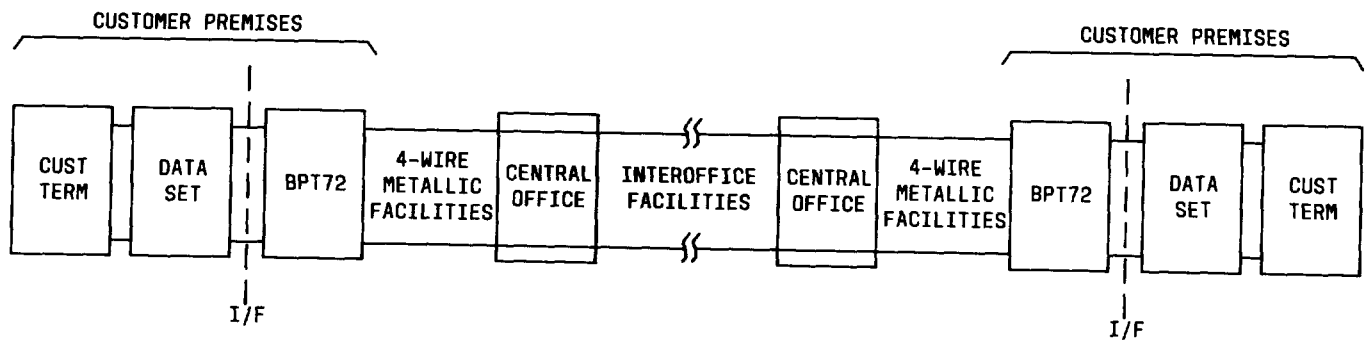

Fig. 3—Equalizer Performance Curves

TABLE D							
TYPICAL BPT72 ATTENUATION DISTORTION (CHANNEL GAIN RELATIVE TO 0 dB AT 1000 Hz)							
CHANNEL	FREQUENCY						
	200	300	400	1000	2000	2800	3400
Transmit	-0.4	-0.3	-0.2	0.0	0.0	-0.1	0.0



(A) 4-WIRE POINT-TO-POINT
PRIVATE LINE DATA CIRCUIT
WITH 2-WIRE CUSTOMER INTERFACE



(B) 4-WIRE POINT-TO-POINT
PRIVATE LINE DATA CIRCUIT
WITH 4-WIRE CUSTOMER INTERFACE

Fig. 4—Typical Applications of BPT72

TABLE E			
GAIN AND EQUALIZATION FACTORS			
CABLE TYPE	1-KHZ GAIN REQUIRED PER KFT	1-KHZ GAIN REQUIRED PER MILE	EQUALIZATION REQUIRED PER KFT (NOTE)
H88 LOADED CABLE			
22 Gauge	0.15 dB	0.8 dB	0.0 dB
24 Gauge	0.23 dB	1.2 dB	0.0 dB
26 Gauge	0.34 dB	1.8 dB	0.0 dB
D66 LOADED CABLE			
22 Gauge	0.15 dB	0.8 dB	0.0 dB
24 Gauge	0.23 dB	1.2 dB	0.0 dB
NONLOADED CABLE			
22 Gauge	0.34 dB	1.8 dB	0.25 dB
24 Gauge	0.44 dB	2.3 dB	0.25 dB
26 Gauge	0.54 dB	2.9 dB	0.25 dB
Note: For equalizer settings, see paragraph 4.06.			

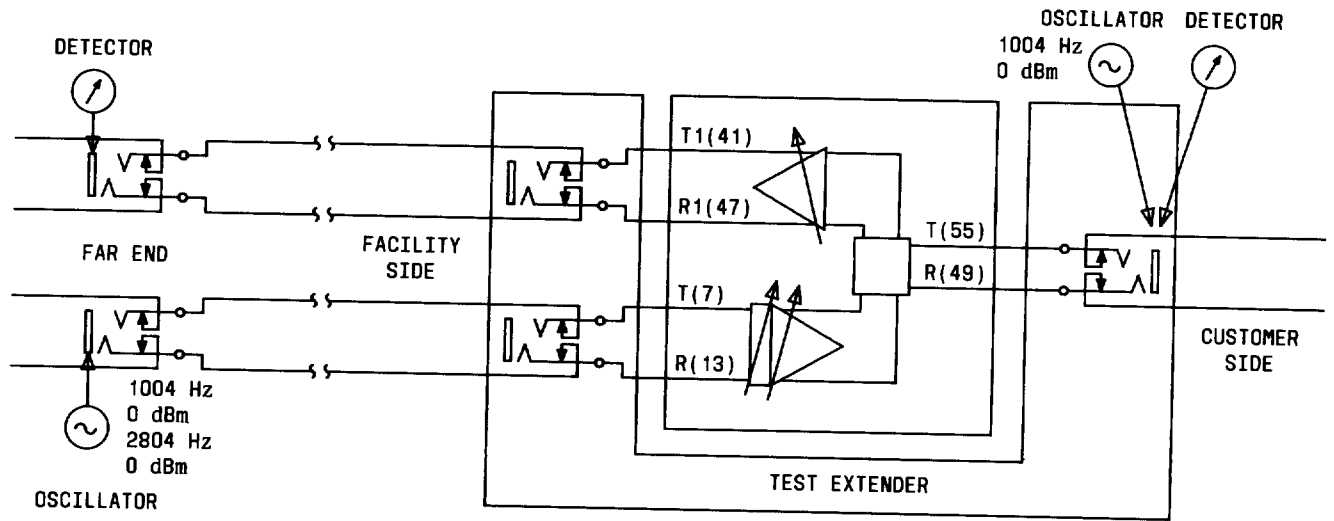

(A) 2-WIRE INTERFACE

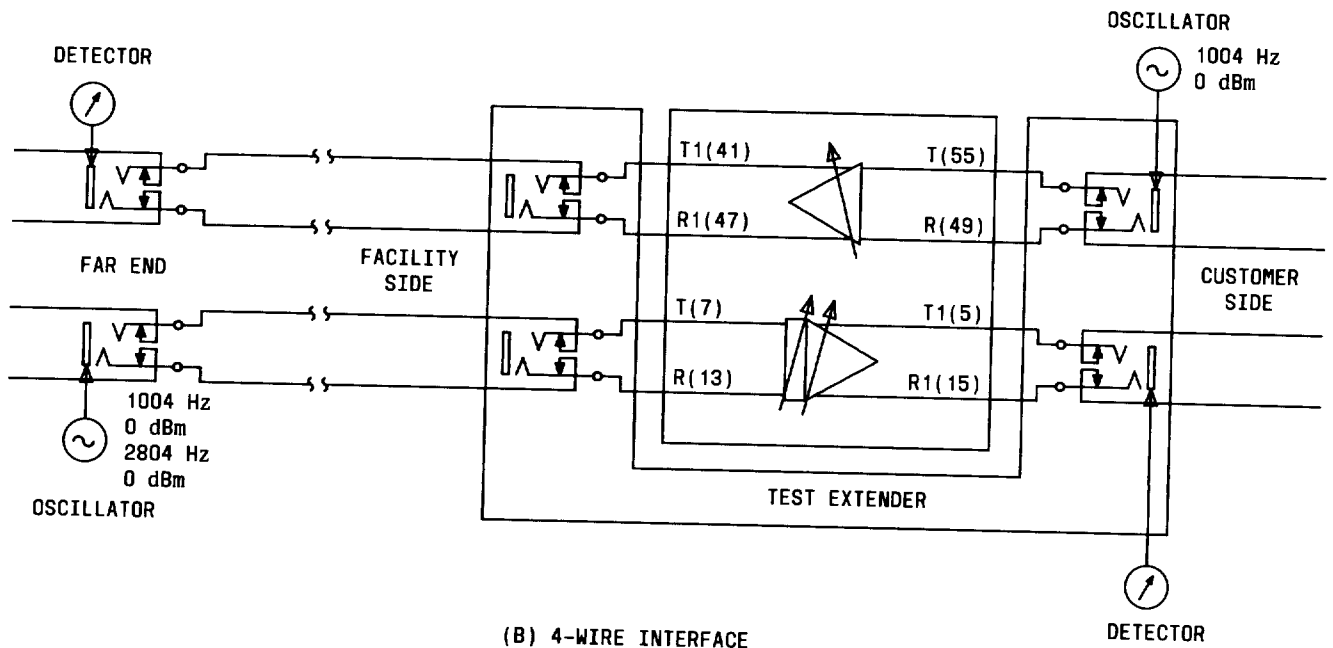

(B) 4-WIRE INTERFACE

Fig. 5—Gain and Equalizer Adjusting Arrangements