

**J99343GC LOOP SIGNALING REPEATER (LOOP-START ONLY)/2-2 WIRE
INTERMEDIATE REPEATER (L-L) COMBINED FUNCTION UNIT**

DESCRIPTION

METALLIC FACILITY TERMINAL

CONTENTS	PAGE	Physical Description
1. GENERAL	1	1.03 This equipment generates and uses radio frequency energy. It has been type tested and found to comply with the limits for a Class B computing device in accordance with the specifications in Subpart J of Part 15 of FCC rules, which are designed to provide reasonable protection against radio frequency interference in commercial and residential installations. However, there is no guarantee that interference will not occur in a particular installation. If this equipment does cause interference to radio or television reception, the user may find the following booklet, prepared by the Federal Communications Commission, helpful:
2. FUNCTIONAL DESCRIPTION—J99343GC	2	
A. Operation	2	
B. Unit Controls	2	
3. PERFORMANCE CHARACTERISTICS	5	
A. Amplifier Frequency Response	5	
B. Envelope Delay Distortion	5	
C. Longitudinal Balance	5	“How to Identify and Resolve Radio-TV Interference Problems.”
D. Output Power Capability	5	This booklet is available from the U.S. Government Printing Office, Washington, D.C. 20402, Stock No. 004-000-00345-4.
4. APPLICATIONS	5	
5. MAINTENANCE	7	
6. REFERENCES	7	
1. GENERAL		
1.01 This section provides a physical description and discusses the basic functions of the Loop Signaling Repeater (LSR) (Loop-Start Only [LSO])/2-2 Wire Intermediate Repeater (L-L) Combined Function Unit (CFU) (J99343GC). The basic CFU is described in detail, and transmission and signaling performance, typical applications, and maintenance philosophy are also discussed.		
1.02 This section is reissued to provide a general update of information. Since this is an extensive revision, change arrows have been omitted.		
		1.04 The Metallic Facility Terminal (MFT) is a standard equipment arrangement for providing various transmission and signaling functions that may be required by metallic facilities. The LSR (LSO)/2-2 wire intermediate CFUs are MFT plug-ins that consist of a component board held by a molded polycarbonate frame. The MFT unit measures 1-11/16 inches wide, 7-7/8 inches high, and 9 inches deep.
		1.05 The CFUs combine the functions of a transmission unit and a signaling unit on a single plug-in. The CFUs can be used in either a single- or double-module mounting arrangement. They can be mounted in any slot of a single-module shelf. When a CFU is used in the double-module arrangement, it is mounted in the transmission slot. The companion

NOTICE

Not for use or disclosure outside the
Bell System except under written agreement

signaling unit slot must be vacant. Section 332-910-101 contains additional information on MFT mounting arrangements.

Note: On early versions of some MFT double-module frames, ringing and talk battery may not be available in the transmission slot. Strap wire may need to be added from the signaling slot. Ringing should be connected from pin J2-7 (SU) to J1-30 (TU), and talk battery from pin J2-20 (SU) to pin J1-20 (TU).

1.06 The J99343GC is the LSR (LSO)/2-2 Wire Intermediate Repeater (L-L) CFU. This CFU provides the functions required for the Loop Signaling Repeater (Loop-Start Only) J99343AD and the 2-2 Wire Intermediate Repeater (L-L) J99343PH, List 2. It provides regeneration of loop-start signals, including distinctive ringing and hybrid balance for the loaded facility on both sides.

1.07 Section 332-912-254 provides installation and testing and touch-up procedures for the J99343GC.

2. FUNCTIONAL DESCRIPTION—J99343GC

2.01 The J99343GC is shown in Fig. 1. It provides gain, equalization, and dc range extension on 2-wire circuits between loaded facilities. Figure 2 shows a block diagram of this unit.

A. Operation

Transmission

2.02 Amplifier Units: Adjustable gain and fixed equalization is provided for each direction of transmission. The controls for gain are designated GAIN ADJ and 8 dB. The range of the amplifier unit gain is 0 to 15.75 dB.

Note: For crosstalk considerations, the maximum gain on CFU intermediate repeaters typically is limited to 12 dB.

2.03 Facility Canceler Hybrid: The facility canceler hybrid splits the 2-wire transmission interface into a 4-wire path through the repeater. This allows gain and equalization to be provided in each direction of transmission. The facility canceler hybrid is matched to the 2-wire loaded facility using the GAUGE switches.

2.04 Line Build-Out Capacitor: The line build-out capacitor (LBOC) network is used on the 2-wire loaded cable interface(s) to build out the end

section to an equivalent of 6 kft. The switches that control the LBOC are designated 02, 04, 08, 16, 32, and 64.

Signaling

2.05 The signaling section of this unit provides the functions required for regeneration of loop-start signals. These functions include loop-closure signaling, dial pulse correction, ringing signaling (2 modes), and ring-trip.

2.06 Loop-Closure Detector and Pulse Corrector: The loop-closure detector detects switchhook signals and dial pulses from the station-side equipment and transmits these signals to the pulse corrector. The pulse corrector transmits the corrected loop signals toward the A-side switching equipment. The loop-closure detector also provides a 72-volt talk-battery supply with current limiting.

2.07 Ringing Circuitry: The ringing circuitry detects ringing signals on the A-side of the unit and connects a local ringing source to the station-side (B-side) loop. The ringing circuitry operates in two modes: the normal mode and the distinctive ringing reject mode. The selection of the modes is controlled by the DRR switch.

2.08 Ring-Trip Detector: The ring-trip detector detects station off-hook signals during the ringing interval and causes a loop closure to be transmitted toward the switching equipment. The ring-trip signal also causes the local ringing to be removed from the station loop. During the silent interval, the station off-hook signals are detected by the loop-closure detector causing the ringing circuitry to be removed.

2.09 Switch-Side Current Limiter: An automatic current limiter is provided in the switching-side circuitry to limit the loop current on short loops.

B. Unit Controls

2.10 The rocker-type switches for a particular function, which are described in the following paragraphs, are operated when depressed toward the respective designation. The sum of the values of the switches operated is the setting for that function. The unit controls are illustrated in Fig. 1.

Transmission

2.11 GAIN ADJ and 8 dB: Five miniature switches (designated GAIN ADJ) and a group

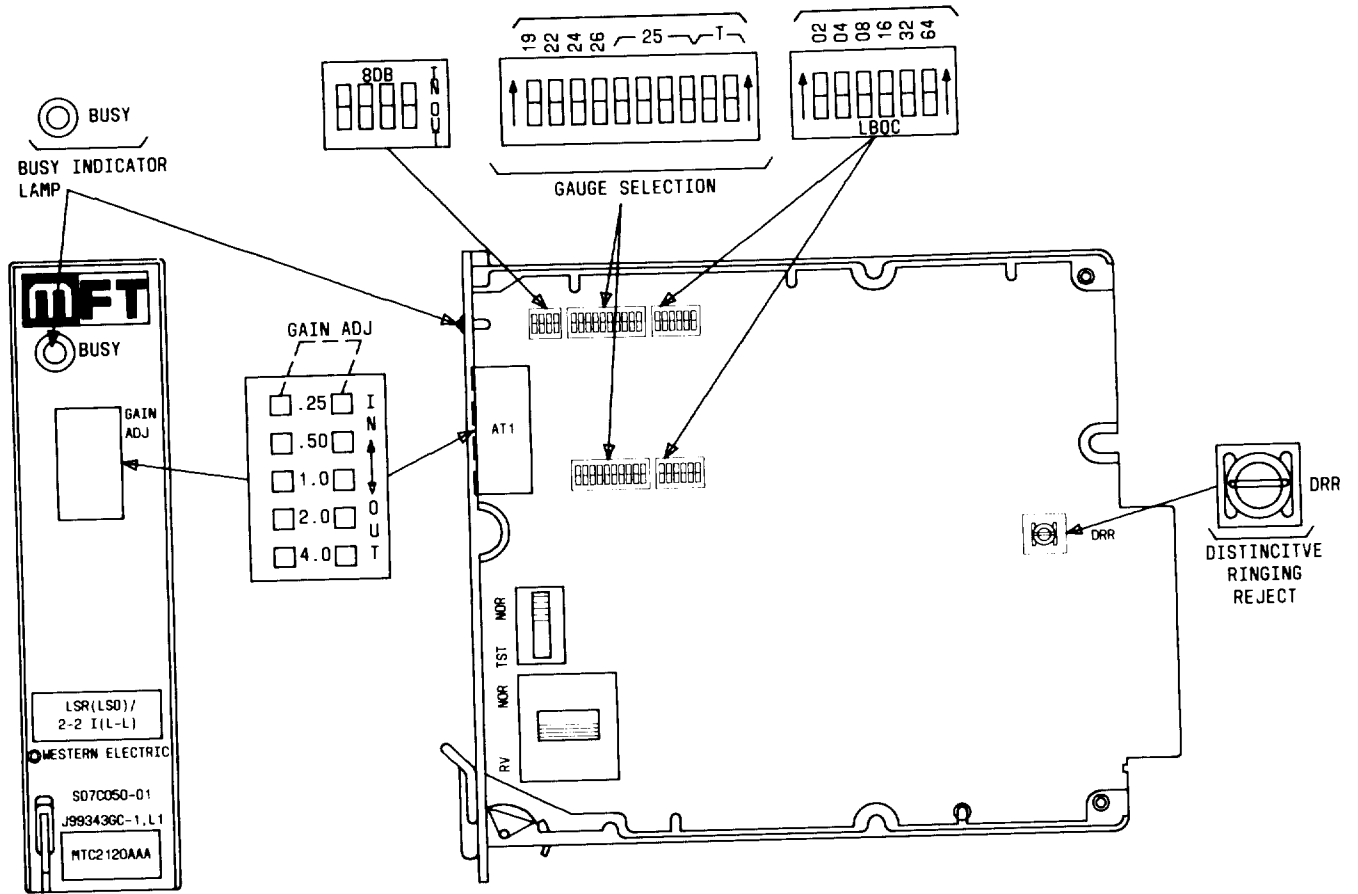

Fig. 1 — Pictorial of J99343GC Combined Function Unit

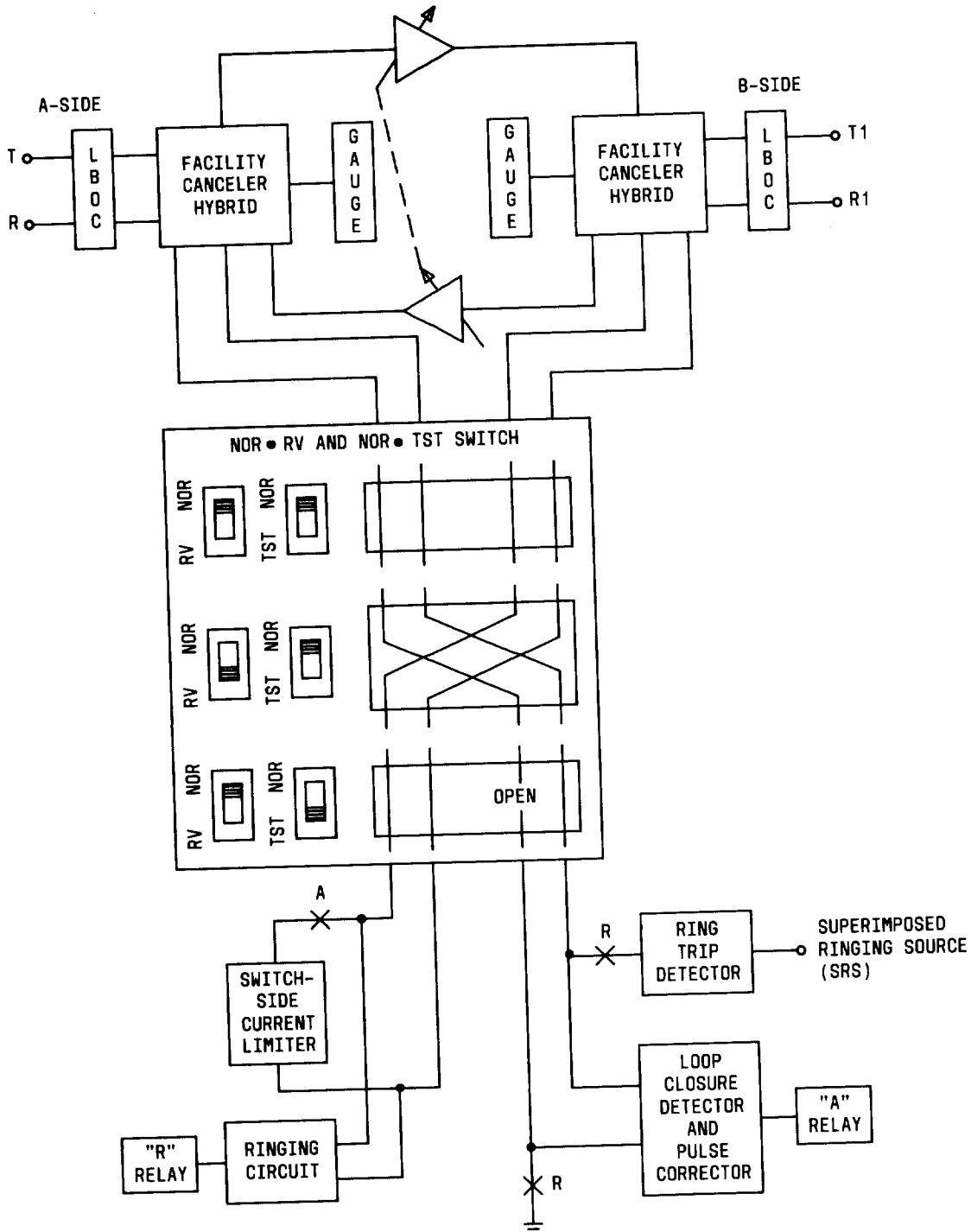

Fig. 2—Block Diagram of J99343GC Combined Function Unit

of four other switches (labeled 8 dB) control the gain of the repeater. The GAIN ADJ switches, accessible through the front panel, are labeled .25, .5, 1.0, 2.0 and 4.0 (dB). These switches are ganged to provide the same gain in both directions of transmission. The 8 dB switches, located on the component board, can provide 8 dB of additional gain in each direction (see Note). See Note in paragraph 2.02.

Note: For proper operation, all four switches labeled 8 dB must be in the same position, ie, all IN or all OUT.

2.12 GAUGE: The GAUGE switches consist of ten rocker switches. Four switches are labeled 19, 22, 24, and 26; four are labeled 25; and two are labeled T. The numbers correspond to the cable gauge of the facility that the repeater interfaces. To set the unit to 25-gauge cable, all four switches labeled 25 must be operated toward 25. For a mixed gauge facility, the predominant gauge determines the gauge setting. Only one gauge setting may be used at a time. Two additional rocker switches, labeled T, provide a compromise balance to accommodate the application where the switching-side facility has an impedance of 900 ohms. None of the associated gauge or LBOC switches should be operated for this application. This feature allows the repeater to be used as an LSR (LSO)/2-2 Wire Terminal Repeater (NL) CFU.

2.13 LBOC: The controls for the LBOC consist of a group of six rocker switches labeled 02, 04, 08, 16, 32, and 64. These switches control the selection of capacitor values from 0 to 0.126 μF in 0.002 μF increments. Section 332-912-254 provides a setting table for the LBOC.

Signaling

2.14 TST·NOR: This switch provides a special test arrangement for the CFU. With the switch in the TST position, the repeater section can be tested independently of the signaling section. In this arrangement the station-side loop is open (no talk-battery to damage test equipment) and the repeater is continuously activated. In the NOR position, the CFU operates in the normal manner.

2.15 NOR·RV: This switch is used to establish a signaling mode of either normal or reverse. Figure 2 gives the required switch positions to achieve a prescribed mode. This switch only affects the dc path to the signaling section.

2.16 DRR: The distinctive ringing reject (DRR) switch selects the ringing mode. In the UP

position, the unit will detect and regenerate all ringing patterns. In the DOWN position, "ring-ping" is rejected and any ringing signal greater than 140 milliseconds will be converted to a standard 2-second signal.

Note: On lines required to pass distinctive ringing patterns, tandem arrangements of distinctive ringing type units are not recommended. Reproduction of the distinctive ringing patterns in tandem arrangements cannot be guaranteed.

3. PERFORMANCE CHARACTERISTICS

3.01 The performance of the J99343GC CFU is discussed in the following paragraphs. Table A gives a summary of characteristics for the LSR (LSO)/2-2 intermediate repeater (L-L) CFU.

A. Amplifier Frequency Response

3.02 Figure 3 gives the amplifier frequency response of the unit.

B. Envelope Delay Distortion

3.03 Figure 4 gives the envelope delay distortion for the repeater.

C. Longitudinal Balance

3.04 The longitudinal balance for these repeaters is at least 58 dB from 200 Hz to 3000 Hz.

D. Output Power Capability

3.05 Figure 5 shows the output power capability of the J99343GC unit. The output power is determined by input power and repeater gain, as shown by the +6 dB gain line in the figure. Power limiting occurs in this unit at about 13.5 dBm.

4. APPLICATIONS

4.01 The J99343GC unit may be used in intermediate applications to provide gain on any 2-wire circuit between loaded facilities. This unit also provides a switch-selectable option, labeled T, which allows it to operate in 900-ohm terminal applications on the loaded facility interface. In this arrangement, The unit operates as a terminal (L) repeater like the J99343PG, List 2. Figure 6 shows a typical application

TABLE A
UNIT CHARACTERISTICS

FUNCTION	J99343GC	
Gain	0 dB to 15.75 dB	
Equalization	Fixed (Fig. 3)	
Hybrid Balance A-Side B-Side	Facility Canceler and LBOC Facility Canceler and LBOC	
DC Resistance A-Side B-Side	410Ω @ 23 mA 72V Supply Regulated @ 40 mA	
Current Drain	Circuit Battery (Terminal 11)	Talk Battery (Terminal 20)
	Idle Busy Max	20 mA 90 mA 110 mA

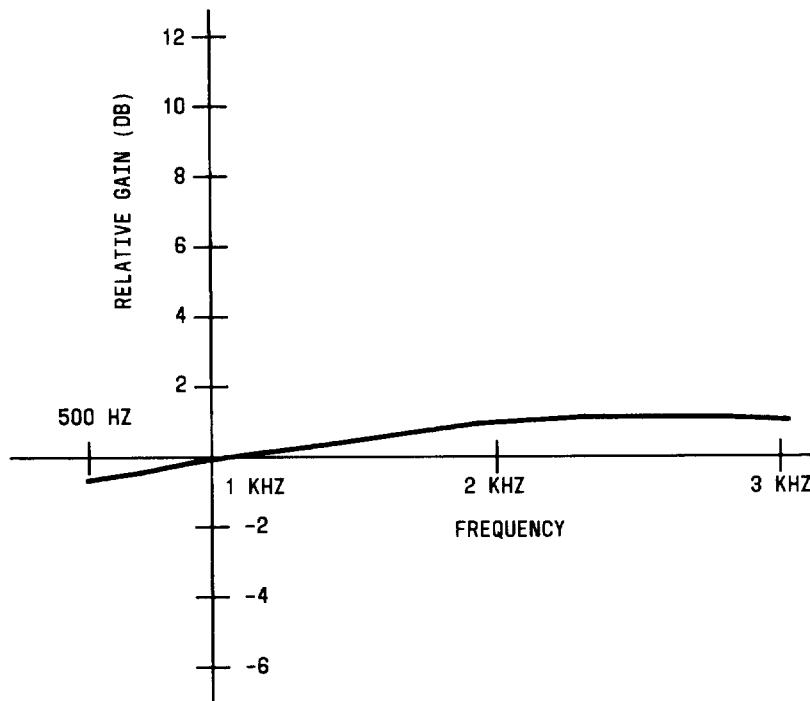

Fig. 3—Gain Frequency Response of J99343GC Combined Function Unit

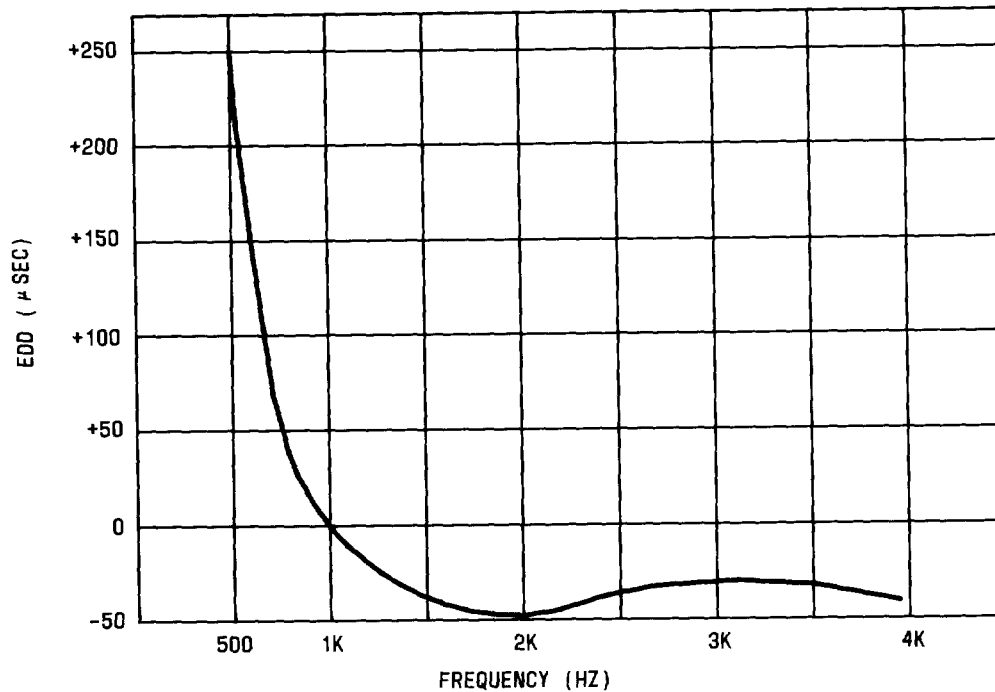

Fig. 4—Envelope Delay Distortion Curve

using the unit in a foreign exchange (FX) line in both intermediate and terminal arrangements. These units also can be used on off-premises station (OPS) lines, wide area telephone service (WATS) trunks and lines, and other metallic facility special service. Section 332-910-180 provides additional information.

Signaling Incompatibilities

4.02 The J99343GC signaling unit section is incompatible with some circuits due to the floating talk-battery on the station side. Circuits monitoring idle or busy conditions with voltages referenced to ground (rather than with loop currents) will not function properly on the J99343GC station loop. Such circuits include the D3 2FXO (J98718BE), the D4 2FXO (J98726BE), the D4 2FXO/GT (J98726SK), the A-side of the MFT LSR (J99343AF), and the line status indicators CPS-RDI.

5. MAINTENANCE

5.01 The MFT repeaters require no routine maintenance. If a repeater is determined to be faulty, it should be removed from service and replaced with

a spare. The defective unit should be sent to the nearest Western Electric Service Center for repair.

6. REFERENCES

6.01 The following references provide additional information concerning 2-2 wire (L) terminal repeaters.

SECTION	TITLE
332-910-100	MFT, General Description
332-910-101	Shelf, Frame, Power Panel, and Distributing Frame Arrangements, Description
332-910-180	General Application Information
332-912-254	J99343GC Installation and Testing

DRAWING

CD-7C050-01	Common Systems, MFT Circuit Description
-------------	---

DRAWING

TITLE

SD-7C050-01

Common Systems, MFT Schematic Drawing

The appropriate numerical index section should be consulted to find the current issue of the sections listed and any addenda that may have been issued. The pertinent numerical index for the sections listed here is 332-000-000.

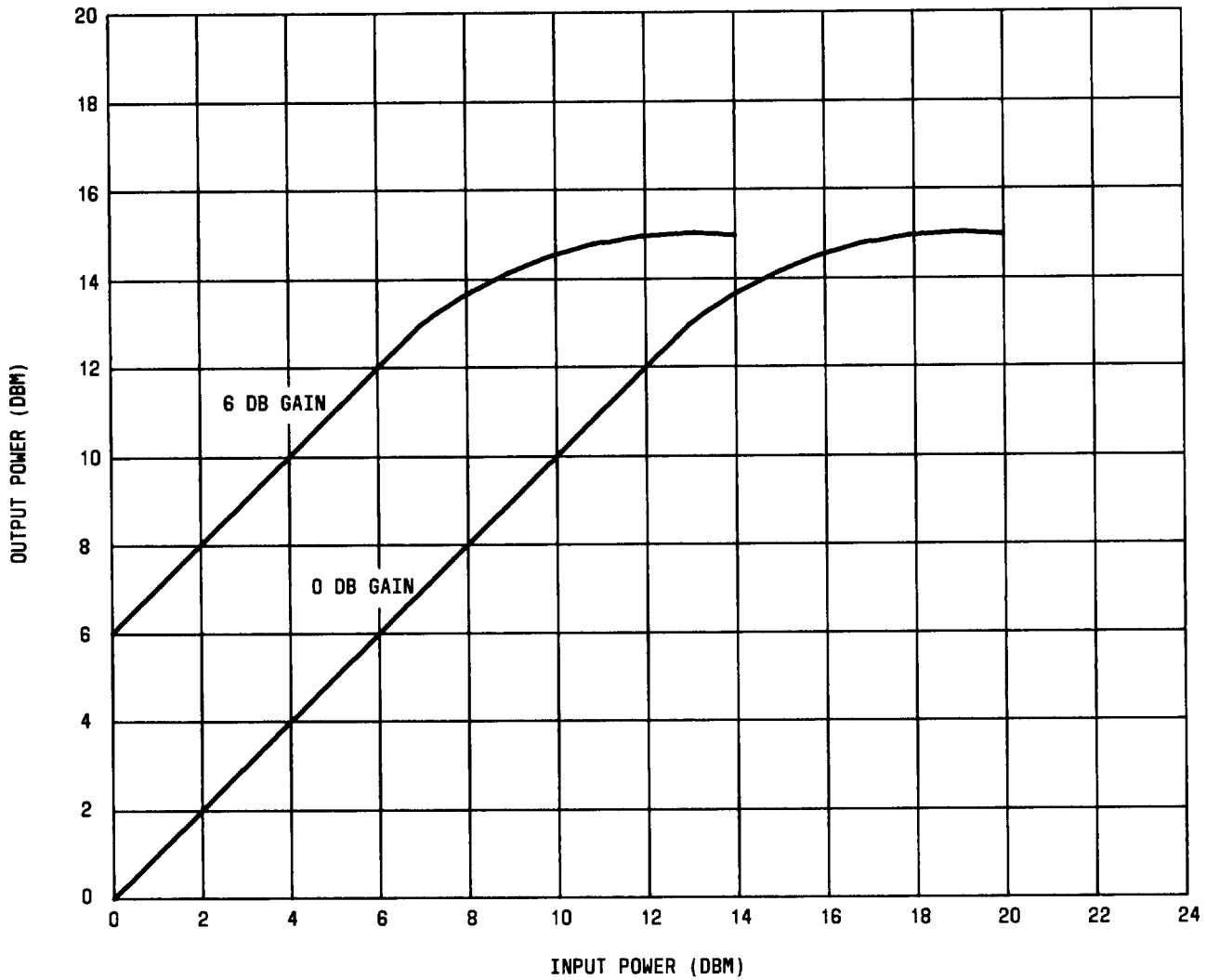

Fig. 5—Output Power Characteristic Curve

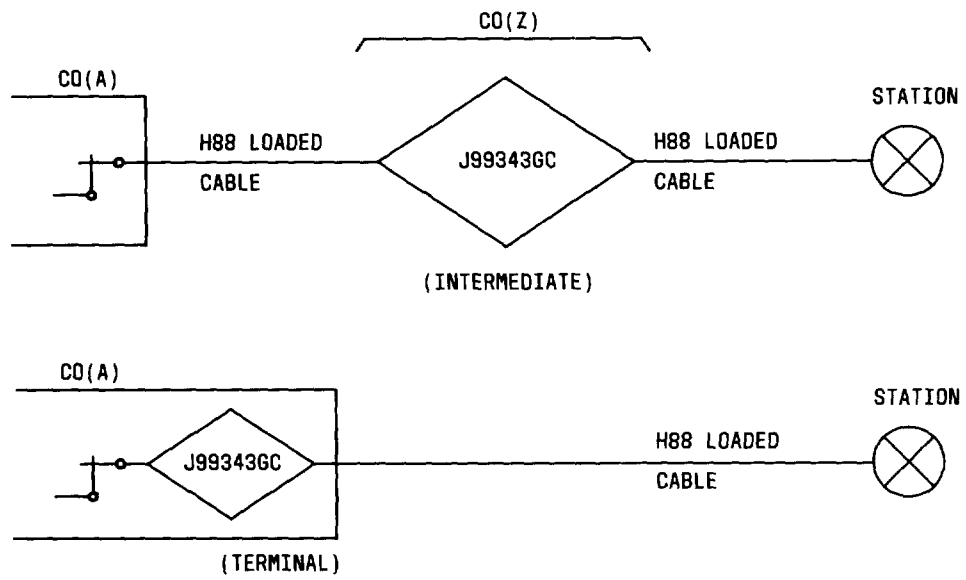

Fig. 6—Foreign Exchange Line Using J99343GC Combined Function Unit

