

**L MULTIPLEX TERMINALS  
COMMON EQUIPMENT  
CARRIER TRANSMISSION MAINTENANCE SYSTEM (CTMS)  
MEASUREMENT OF TERMINAL PILOTS  
AT MASTERGROUP AND LINE ACCESS**

CONTENTS	PAGE	CONTENTS	PAGE
1. GENERAL . . . . .	1	F. PLRX Printout at Mastergroup Access . . . . .	3
2. PLTX PROGRAM . . . . .	1	G. Corrective Action for PLRX at Mastergroup Access . . . . .	4
A. Scheduling PLTX Program . . . . .	2		
B. Transmitting Mastergroup Access Circuits . . . . .	2	1. GENERAL	
C. PLTX Printout at Mastergroup Access . . . . .	2	1.01 Terminal pilots of transmitting facilities are measured by the PLTX program, and terminal pilots of receiving facilities are measured by the PLRX program. Each program, in turn, measures the facilities at mastergroup access and at line access, thus providing four complete sets of printouts for use in evaluating the condition of terminal pilots in an office. Since PLTX and PLRX are separate programs, the application of each is discussed separately.	
D. Corrective Action for PLTX at Mastergroup Access . . . . .	2	1.02 This section is reissued to reflect printout modifications, add new access circuits, and revise the corrective action procedure. Since this issue constitutes a general revision, arrows ordinarily used to indicate changes are omitted.	
E. Transmitting Line Access Circuits . . . . .	2	2. PLTX PROGRAM	
F. PLTX Printout at Line Access . . . . .	3	2.01 The transmitting pilots at line and mastergroup program PLTX is a routine application program that measures transmitting pilots at both mastergroup and line access points and also measures 104.08-kHz group pilot bus levels at mastergroup access. It may be run as a demand measurement with parameter control.	
G. Corrective Action for PLTX at Line Access . . . . .	3		
3. PLRX PROGRAM . . . . .	3		
A. Scheduling PLRX Program . . . . .	3		
B. Receiving Line Access Circuits . . . . .	3		
C. PLRX Printout at Line Access . . . . .	3		
D. Corrective Action for PLRX at Line Access . . . . .	3		
E. Receiving Mastergroup Access Circuit . . . . .	3		

**NOTICE**

Not for use or disclosure outside the  
Bell System except under written agreement

**A. Scheduling PLTX Program**

**2.02** PLTX in a magnetic tape system is controlled by BOS commands IT (to establish an execution time), ON (to initialize the program for routine running), and ON,PLTX,NOW... (for demand execution). In a disc storage system, one of two methods of control may be used: (1) RTE system commands IT and ON as above for routine execution and RU for demand execution, or (2) control by the auxiliary terminal monitor (ATM) program in which PLTX is initialized by an IP command, scheduled by an IS command, and run as a demand program by an ON,PLTX,NOW... command. The BOS and RTE system commands and the ATM program commands are described in Section 103-260-300.

**2.03** When run as a demand program, PLTX is called on to measure pilots of a specific facility at mastergroup access or at line access. The command to start PLTX for a demand measurement is:

\*ON,PLTX[,NOW],p1 [,p2,p3 ]

in a magnetic tape system or in a disc system when PLTX is under ATM program control, or:

\*RU,PLTX,p1 [,p2,p3 ]

in a disc system using only system commands.

**Where:**

p1 is short code assigned to specific mastergroup or line.

p2 is always zero (enter by default using two commas).

p3 = 0 (or absent) print only out-of-limits measurements.

p3 > 0 print all measurements.

**B. Transmitting Mastergroup Access Circuits**

**2.04** The following circuits provide access to transmitting pilots at mastergroup level and

also 104.08-kHz pilot bus signals for measurement by CTMS:

Fig. 1—LMX-1 and LMX-2 Multiplex Transmitting Mastergroup and Pilot Access Circuit (U600 Configuration)

Fig. 2—LMX-1 and LMX-2 Multiplex Transmitting Mastergroup Access Circuit (L600 Configuration)

Fig. 3—104.08-kHz Pilot Bus Access Circuit (L600 Configuration)

**C. PLTX Printout at Mastergroup Access**

**2.05** Figure 4 illustrates a typical routine PLTX printout when measuring supergroup and group pilots at mastergroup access. The print limits are:

SG pilot:  $\pm 0.5$  dB from nominal.

GR pilot:  $\pm 0.5$  dB from SG.

104.08-kHz pilot bus:  $\pm 0.2$  dB from nominal.

In addition, the average deviation of the group pilots of a mastergroup is printed if any group pilot is out of limits. The meanings of some entries in the heading, measurement results, and summary have been identified for convenience.

**D. Corrective Action for PLTX at Mastergroup Access**

**2.06** Chart 1 is a suggested procedure for correcting transmitting pilot deviations measured at mastergroup access. When trouble has been cleared, follow local procedures to update the maintenance history file.

**E. Transmitting Line Access Circuits**

**2.07** The following circuits provide access to transmitting pilots at line level:

Fig. 5—3A WLEL Transmitting Access Circuit (for TD-2, TD-3, and TH-3)

Fig. 6—TH-1 Transmitting Access Circuit

Fig. 7—L3 Transmitting Access Circuit

Fig. 8—L4 Transmitting Access Circuit

**F. PLTX Printout at Line Access**

**2.08** Figure 9 illustrates a typical routine PLTX printout when measuring mastergroup and supergroup pilots at line access. The print limits are:

MG pilot:  $\pm 0.5$  dB from nominal.

SG pilot:  $\pm 1.0$  dB from nominal.

In addition, the average deviation of the supergroup pilots in a mastergroup is printed if any supergroup pilot is out of limits.

**G. Corrective Action for PLTX at Line Access**

**2.09** Chart 2 is a suggested procedure for correcting transmitting pilot deviations measured at line access. When trouble has been cleared, follow local procedures to update the maintenance history file.

**3. PLRX PROGRAM**

**3.01** The receiving pilots at line and mastergroup program PLRX is a routine application program. It may also be run as a demand measurement with parameter control.

**A. Scheduling PLRX Program**

**3.02** PLRX is scheduled in a manner similar to that described in 2.02 for PLTX routine execution. Demand execution uses the commands and parameter controls described in 2.03.

**B. Receiving Line Access Circuits**

**3.03** The following circuits provide access to receiving pilots at line level:

Fig. 10—3A WLEL Receiving Access Circuit (for TD-2, TD-3, and TH-3)

Fig. 11—TH-1 Receiving Access Circuit

Fig. 12—L3 Receiving Access Circuit

Fig. 13—L4 Receiving Access Circuit

**C. PLRX Printout at Line Access**

**3.04** Figure 14 illustrates a typical routine PLRX printout when measuring mastergroup and supergroup pilots at line access. The print limits are:

MG pilot:  $\pm 2.0$  dB from nominal.

SG pilot (with MG regulation):  $\pm 3.0$  dB from MG.

SG pilot (without MG regulation):  $\pm 4.0$  dB from nominal.

In addition, the average deviation of the supergroup pilots in a mastergroup is printed if any supergroup pilot is out of limits.

**D. Corrective Action for PLRX at Line Access**

**3.05** Chart 3 is a suggested procedure for correcting receiving pilot deviations measured at line access. When trouble has been cleared, follow local procedures to update the maintenance history file.

**E. Receiving Mastergroup Access Circuit**

**3.06** The following circuit provides access to receiving pilots at mastergroup level:

Fig. 15—LMX-1 and LMX-2 Multiplex Receiving Mastergroup Access Circuit

**F. PLRX Printout at Mastergroup Access**

**3.07** Figure 16 illustrates a typical routine PLRX printout when measuring supergroup and group pilots at mastergroup access. The print limits are:

SG pilot (with MG regulation):  $\pm 3.0$  dB from nominal.

SG pilot (without MG regulation):  $\pm 4.0$  dB from nominal.

GR pilot:  $\pm 3.0$  dB from SG.



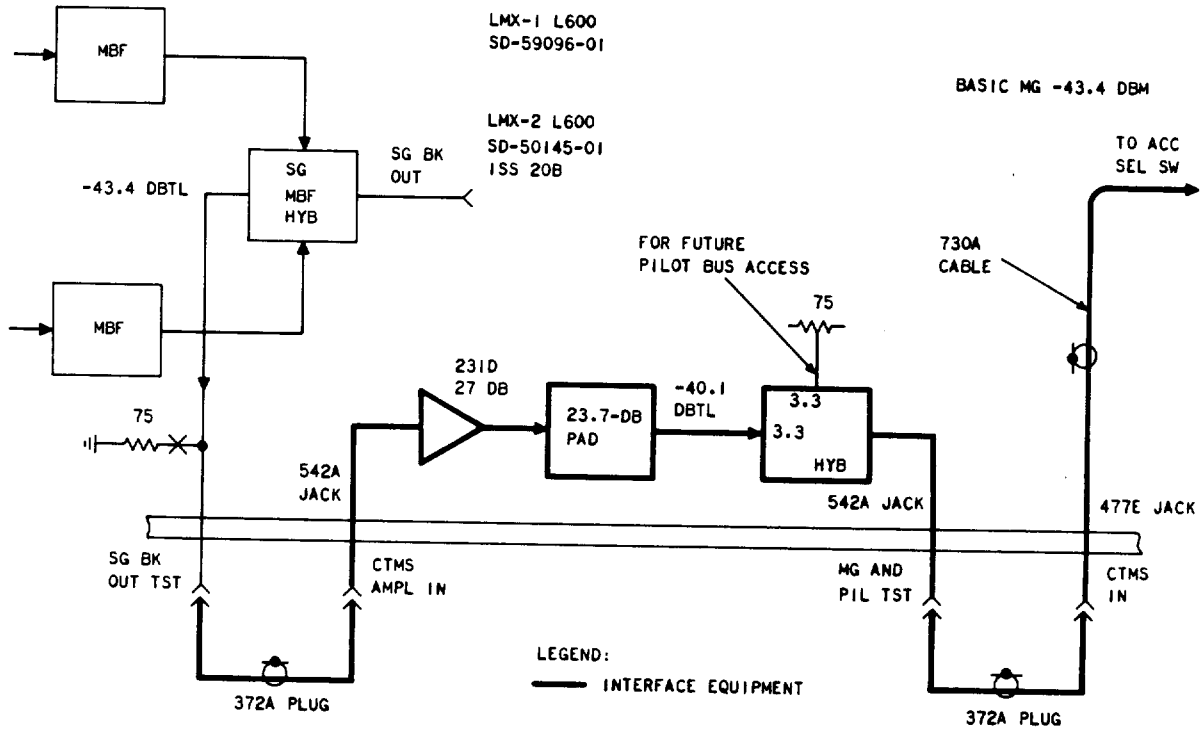

Fig. 2—LMX-1 and LMX-2 Transmitting Mastergroup Access Circuit (L600 Configuration)

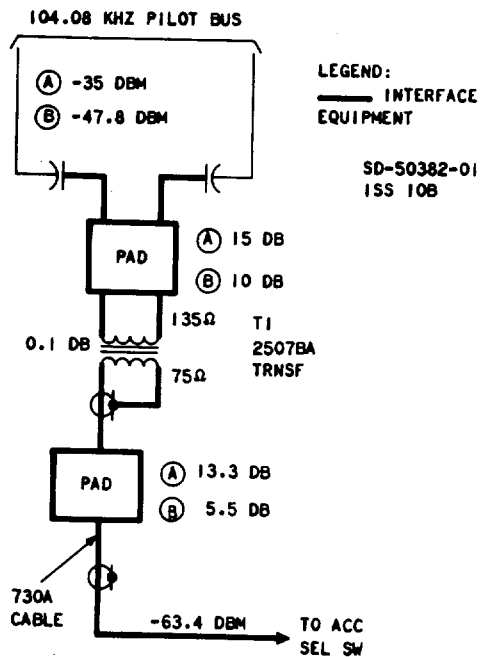

Fig. 3—104.08-kHz Pilot Bus Access Circuit (L600 Configuration)

PROGRAM NAME

ISSUE NO.

PLTX: TERMINAL PILOTS- TRMTG AT LINE & MG ISSUE 4

MG LIM: PB=.2DB;SG=.5DB;GP=.5DB/SG ← PRINT LIMITS (±FROM NOMINAL)

← MG PRINTOUT

\*\*\*\*\*  
 PLTX: DATE 69 19:52 ← DATE AND TIME

MG= 201; 01 MXS AC1 CHSHCT02

NTCNNJNC ← MG IDENTIFICATION

← SHORT CODE OF MG

SG...	GP...	OLD...	NEW...	CHANGE
15	5	.7	.8	.1
17	2	.8	.8	.0
17	4	.8	.8	-.0
18	4	-.8	-1.0	-.1
26	3	-.6	-.7	-.0
28	3	.7	.8	.1
28	4	1.1	1.5	.3
28	5	.9	1.2	.3
AVG		.0	.1	.0

OUT-OF-LIMITS MEASUREMENTS

\*\*\*\*\*

PLTX: DATE 69 20: 0

MG= 404; 01 MXS AF4 BSTNMAFR NTCNNJNC

SG...	GP...	OLD...	NEW...	CHANGE
13	2	-.6	-.6	-.0
13	4	-.7	-.8	-.2
18	5	.3	.6	.3
26	2	-1.1	-1.0	.1
26	3	-.9	-.7	.2
26	4	-.7	-.7	.0
27	2	-.7	-.6	.0
AVG		-.2	-.2	.0

PROGRAM SUMMARY

- ① NO. OF PILOTS MEASURED
- ② NO. OUT-OF-LIMITS
- ③ PERCENT OUT-OF-LIMITS
- ④ FIGURE OF MERIT

\*\*\*\*\*

PLTX: DATE 69 20: 1

MG= 502; 02 MXS AG2 NTCNNJNC PLCSMA02

SG...	GP...	OLD...	NEW...	CHANGE
16	3	.7	.8	.1
18	4	.4	.7	.3
25	4	.9	.9	-.0
AVG		.0	.0	.0

\*\*\*\*\*

PLTX: MG SUMMARY	DATE	69 21:34		
PP PILOTS=	31	SG PILOTS=	826	GP PILOTS= 2677 ①
#>LIMIT=	3	#>LIMIT=	35	#>LIMIT= 879 ②
%>LIMIT=	9	%>LIMIT=	4	%>LIMIT= 32 ③
		FIG/MERIT=	89.81	FIG/MERIT= 62.69 ④

Fig. 4—PLTX Printout of SG and GR Pilots at Mastergroup Access

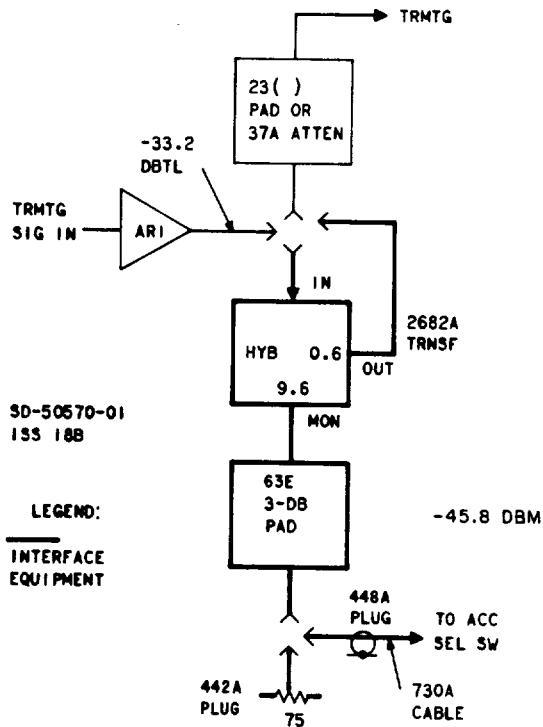

Fig. 5—3A WLEL Transmitting Access Circuit (for TD-2, TD-3, and TH-3)

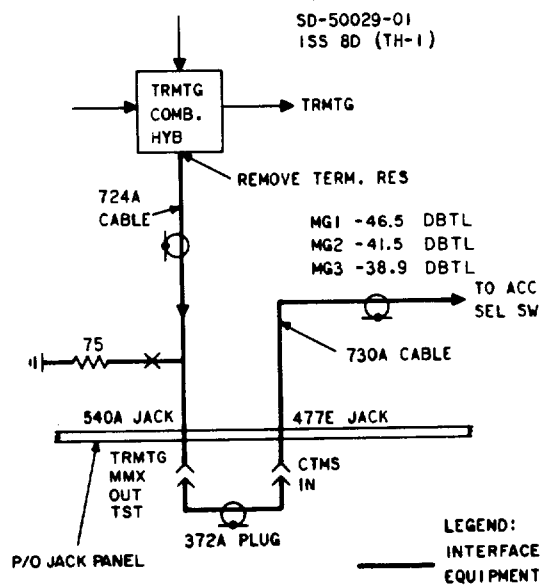

Fig. 6—TH-1 Transmitting Access Circuit

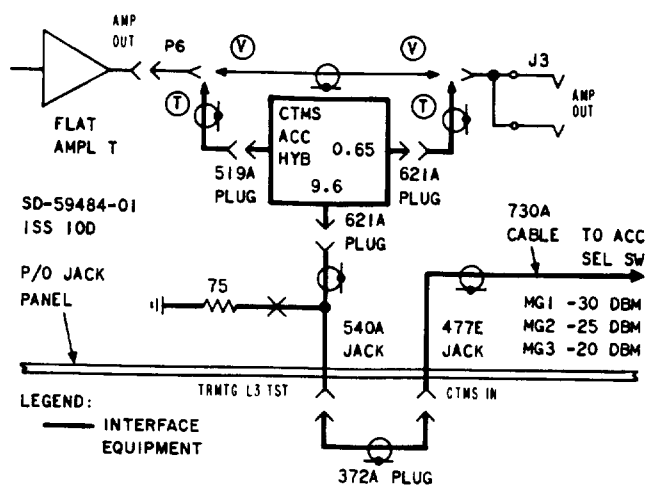

Fig. 7—L3 Transmitting Access Circuit

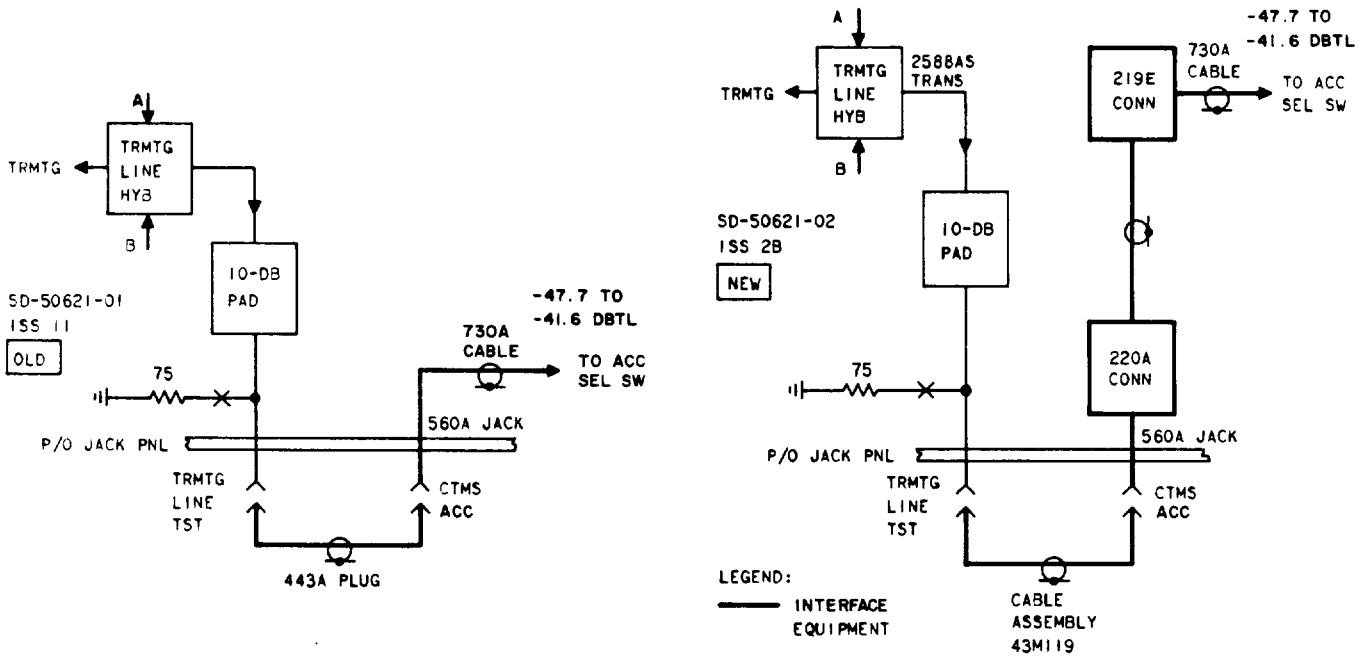

Fig. 8—L4 Transmitting Access Circuit



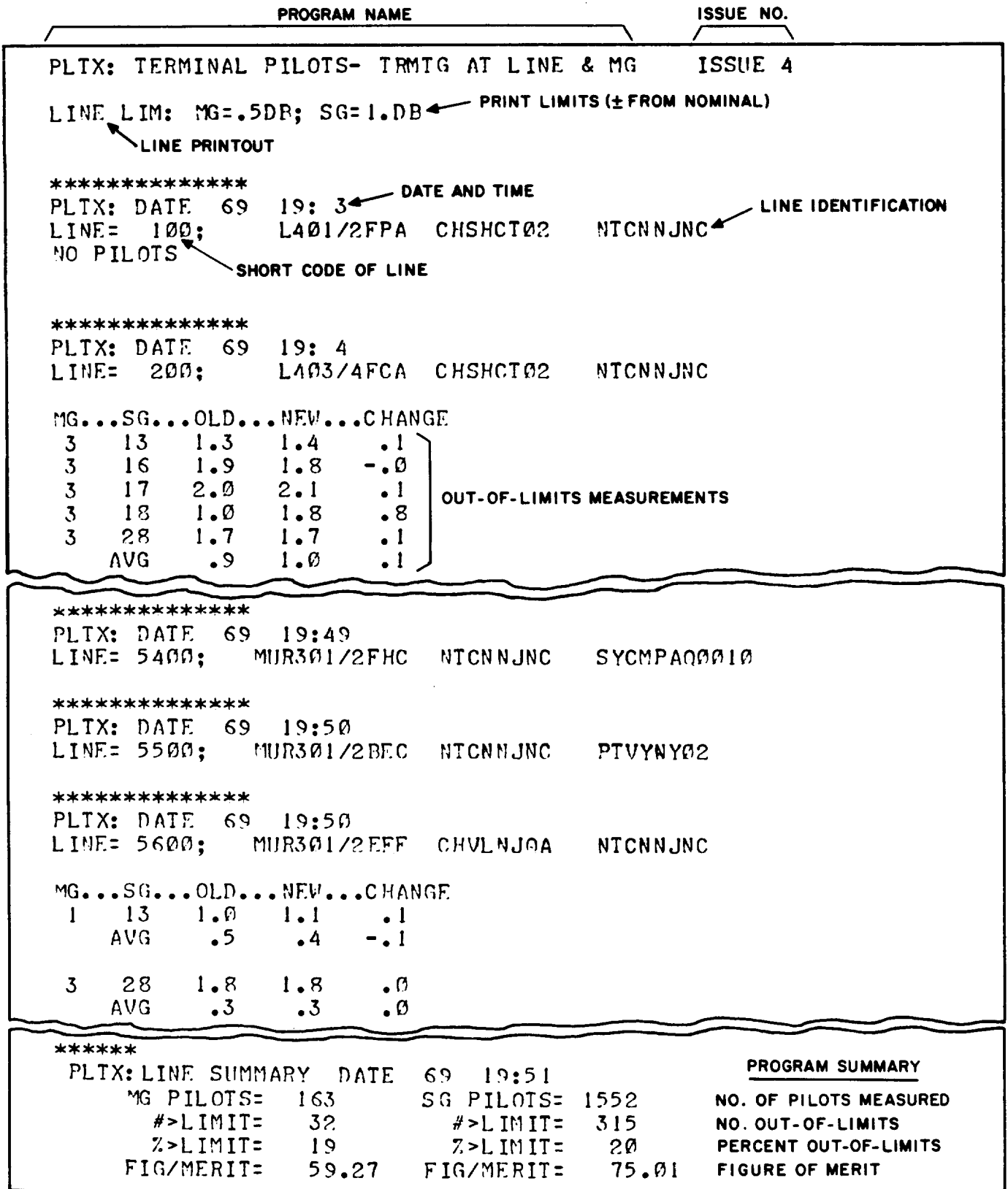

Fig. 9—PLTX Printout of MG and SG Pilots at Line Access

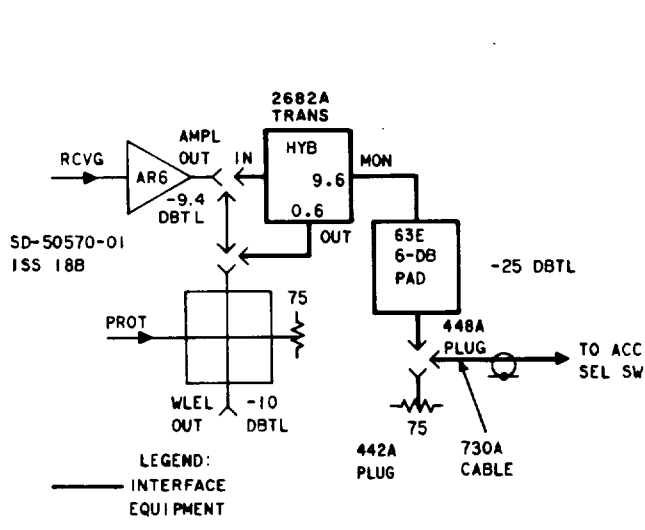

Fig. 10—3A WLEL Receiving Access Circuit (for TD-2, TD-3, and TH-3)

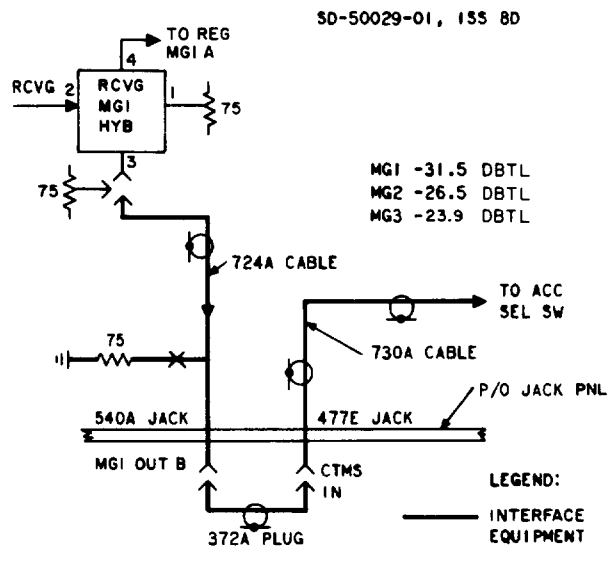

Fig. 11—TH-1 Receiving Access Circuit

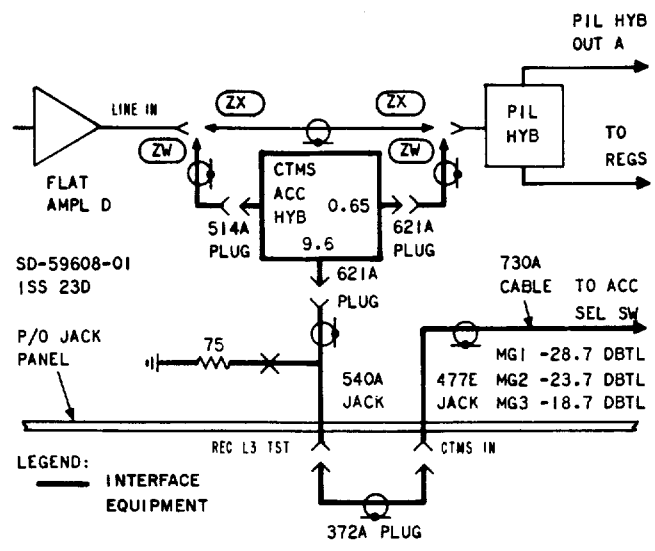

Fig. 12—L3 Receiving Access Circuit

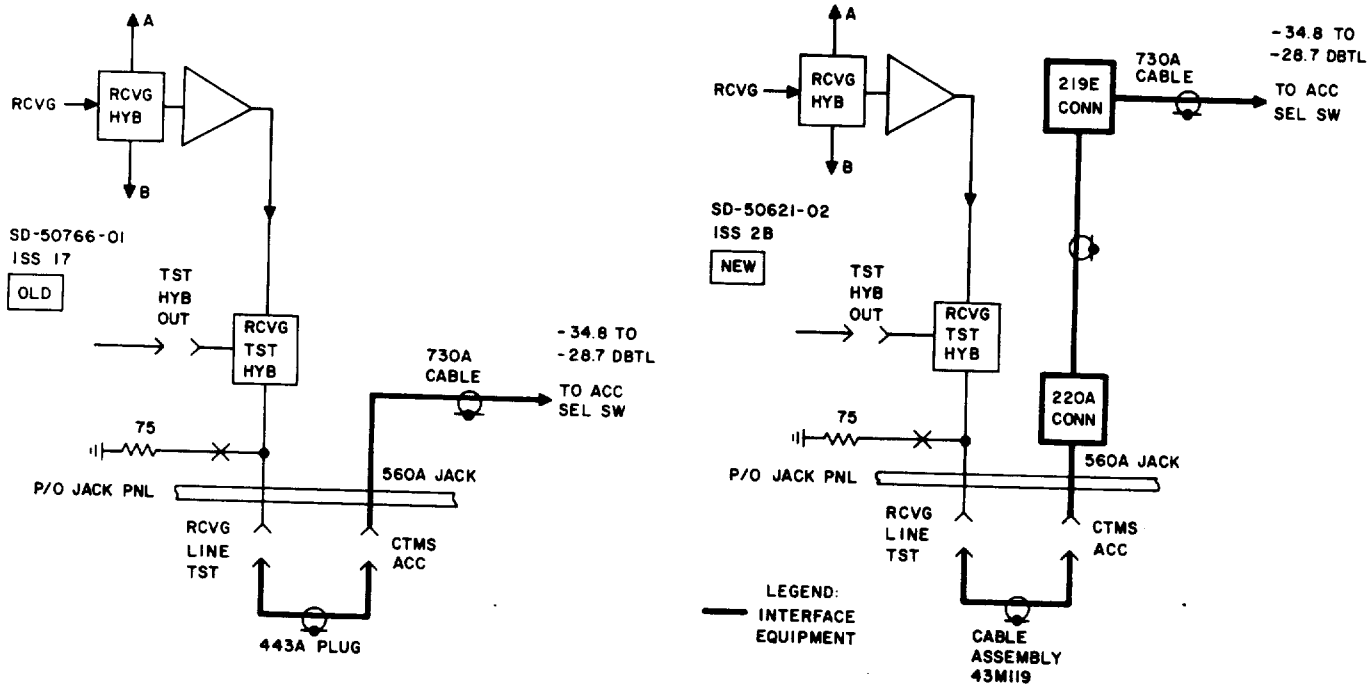

Fig. 13—L4 Receiving Access Circuit

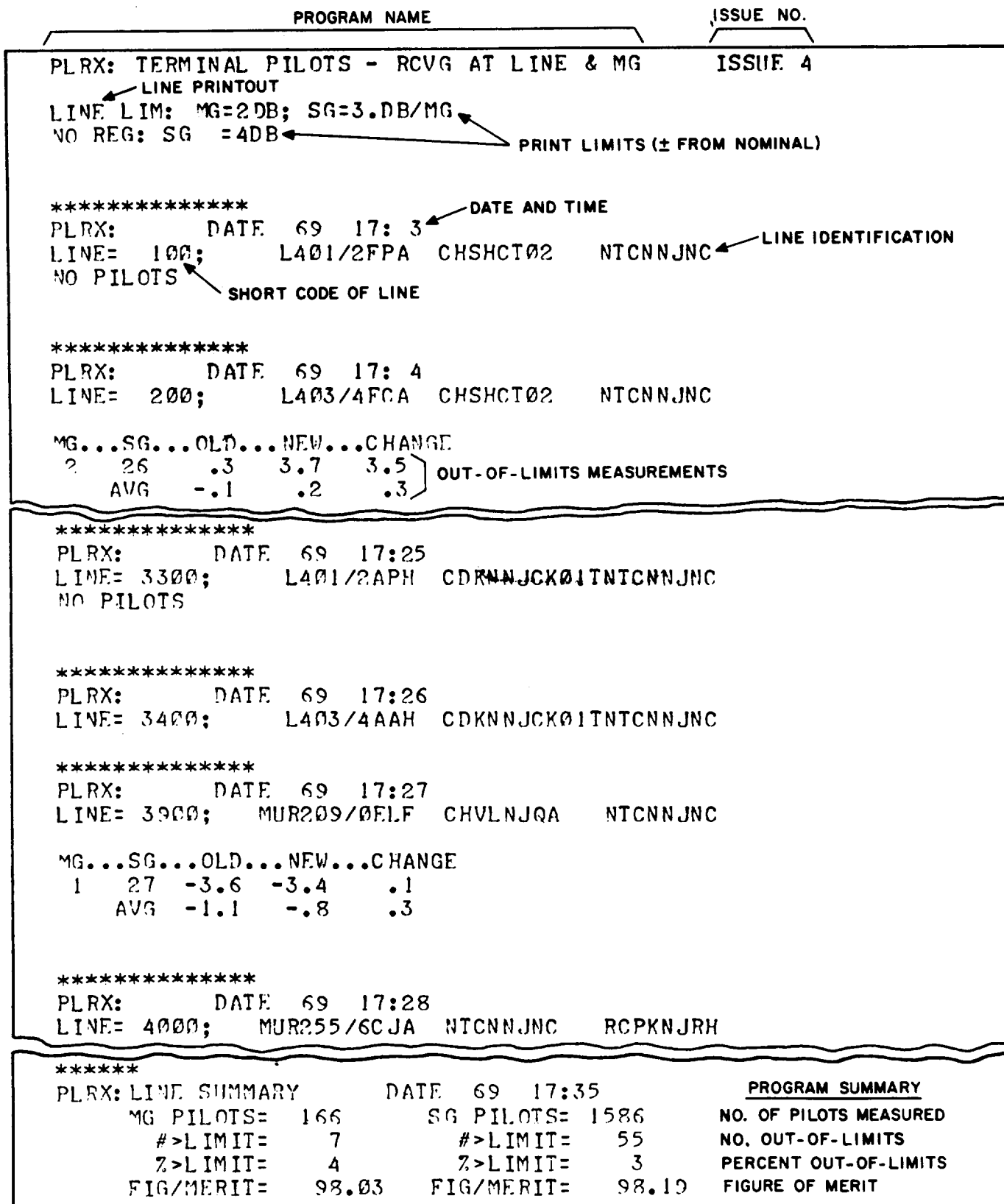

Fig. 14—PLRX Printout of MG and SG Pilots at Line Access

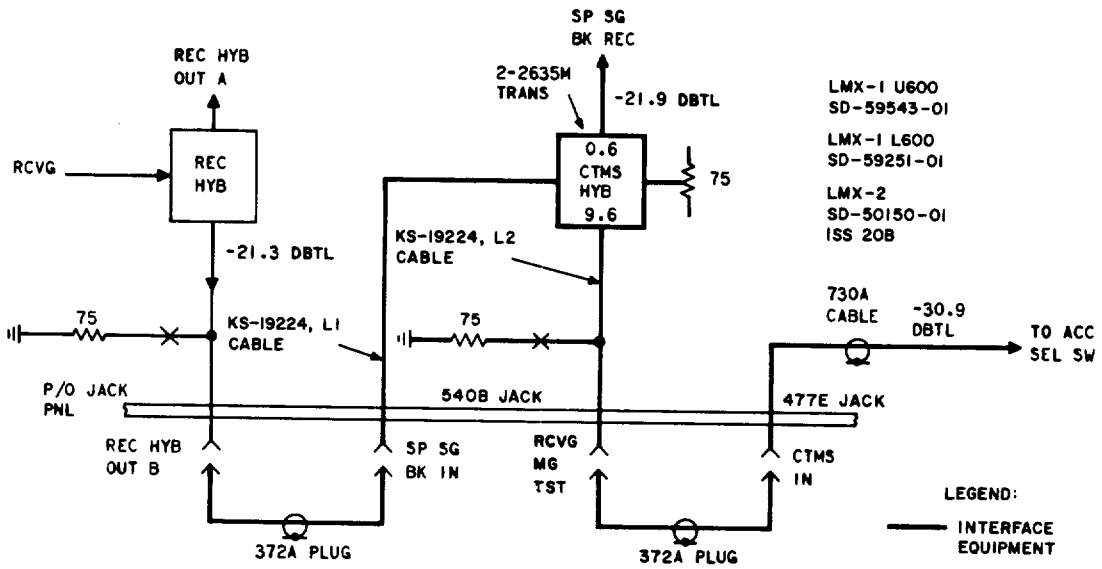

Fig. 15—LMX-1 and LMX-2 Multiplex Receiving Mastergroup Access Circuit

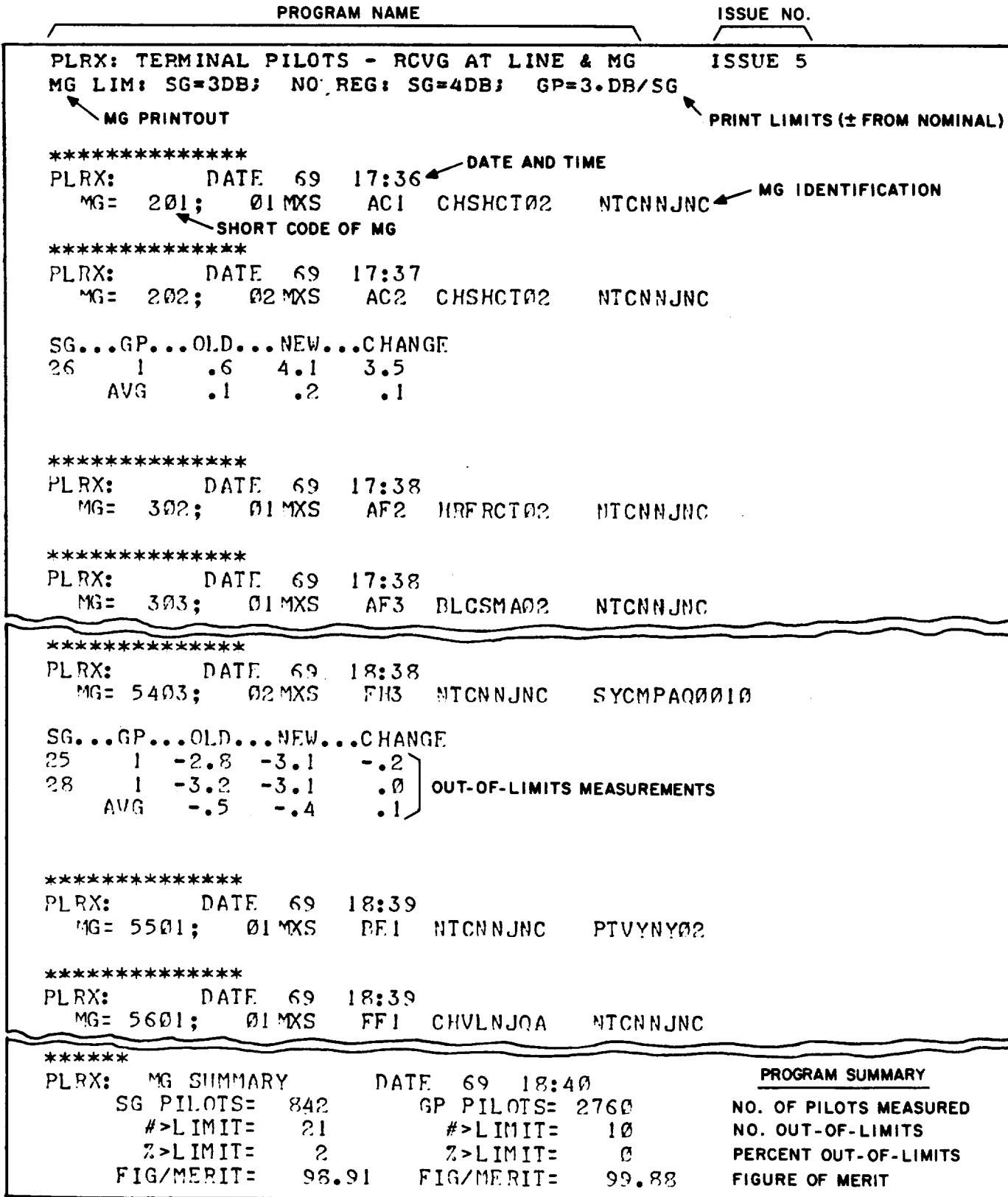

Fig. 16—PLRX Printout of SG and GR Pilots at Mastergroup Access

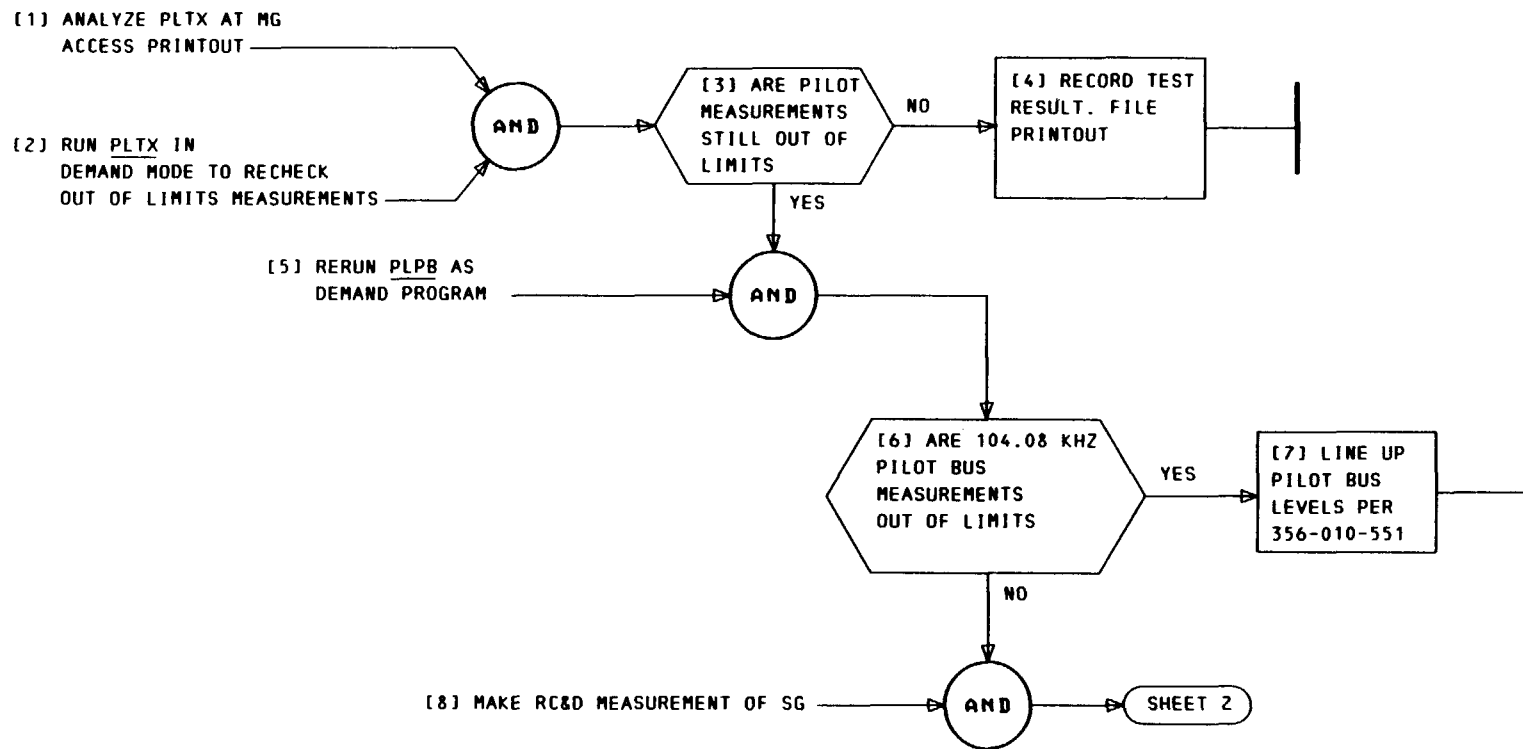

Chart 1—Correct Pilot Deviations of PLTX at Mastergroup Printout (Sheet 1 of 2)

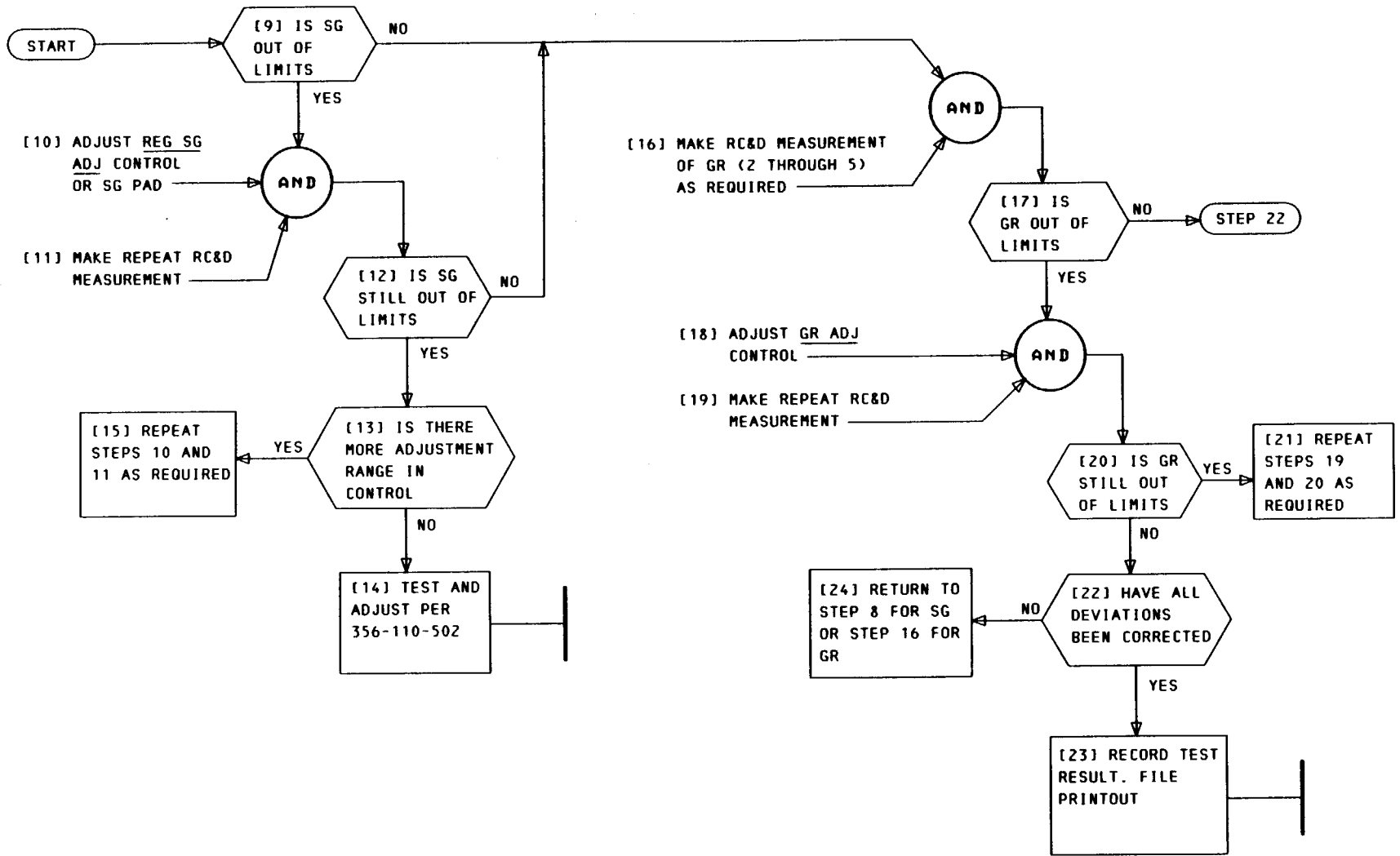

Chart 1—Correct Pilot Deviations of PLTX at Mastergroup Printout (Sheet 2 of 2)



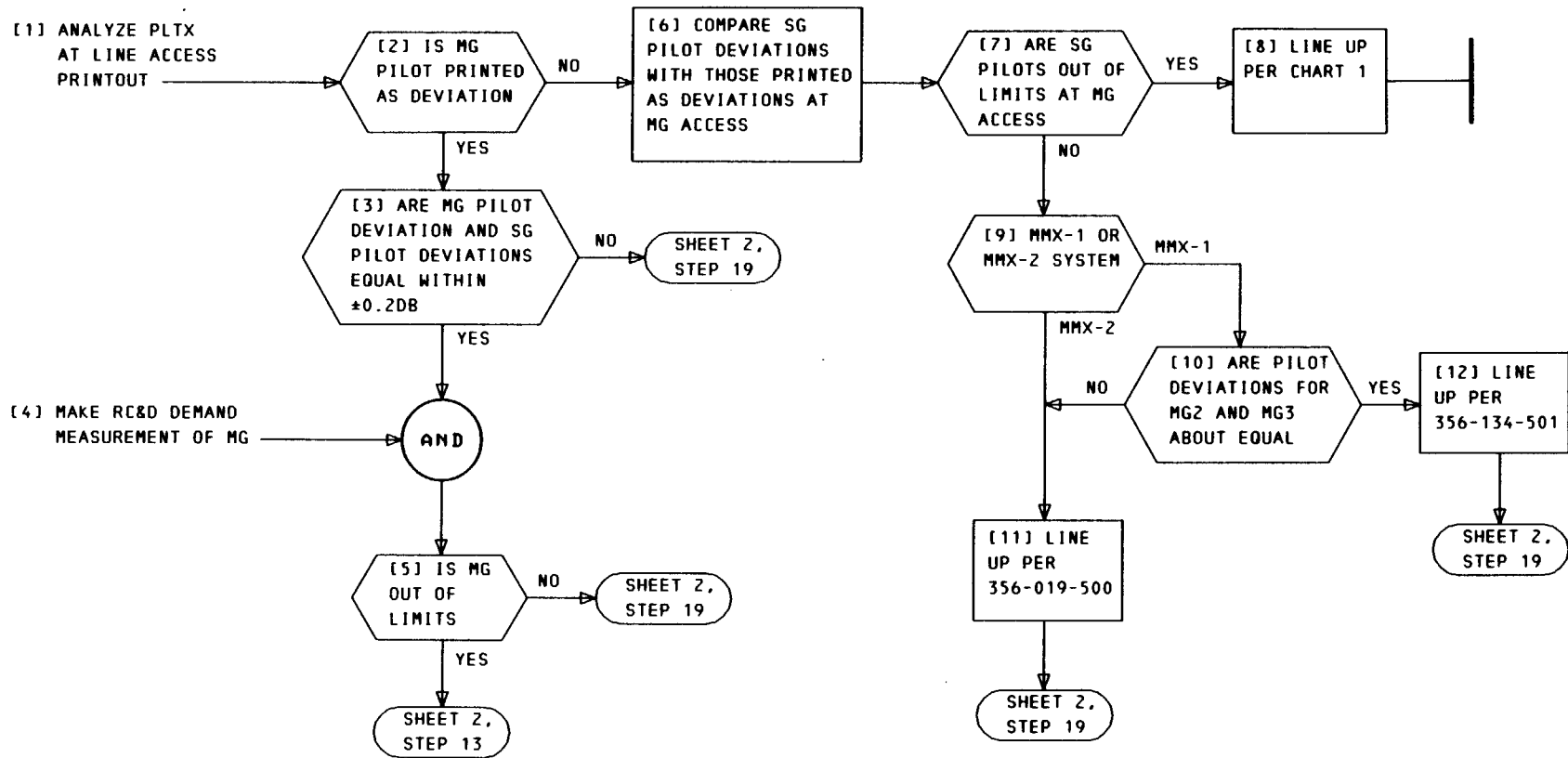

Chart 2—Correct Pilot Deviations of PLTX at Line Printout (Sheet 1 of 2)

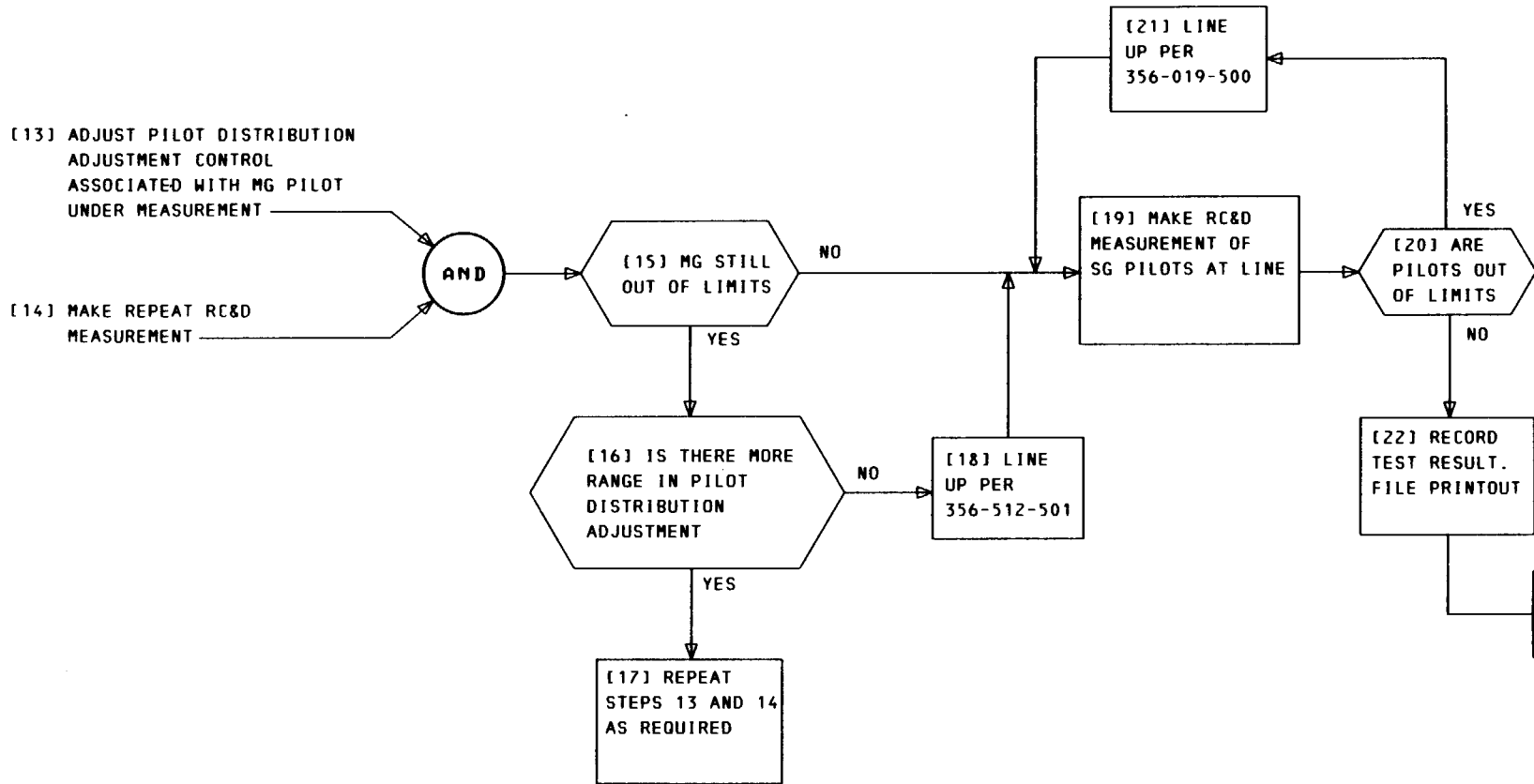

Chart 2—Correct Pilot Deviations of PLTX at Line Printout (Sheet 2 of 2)

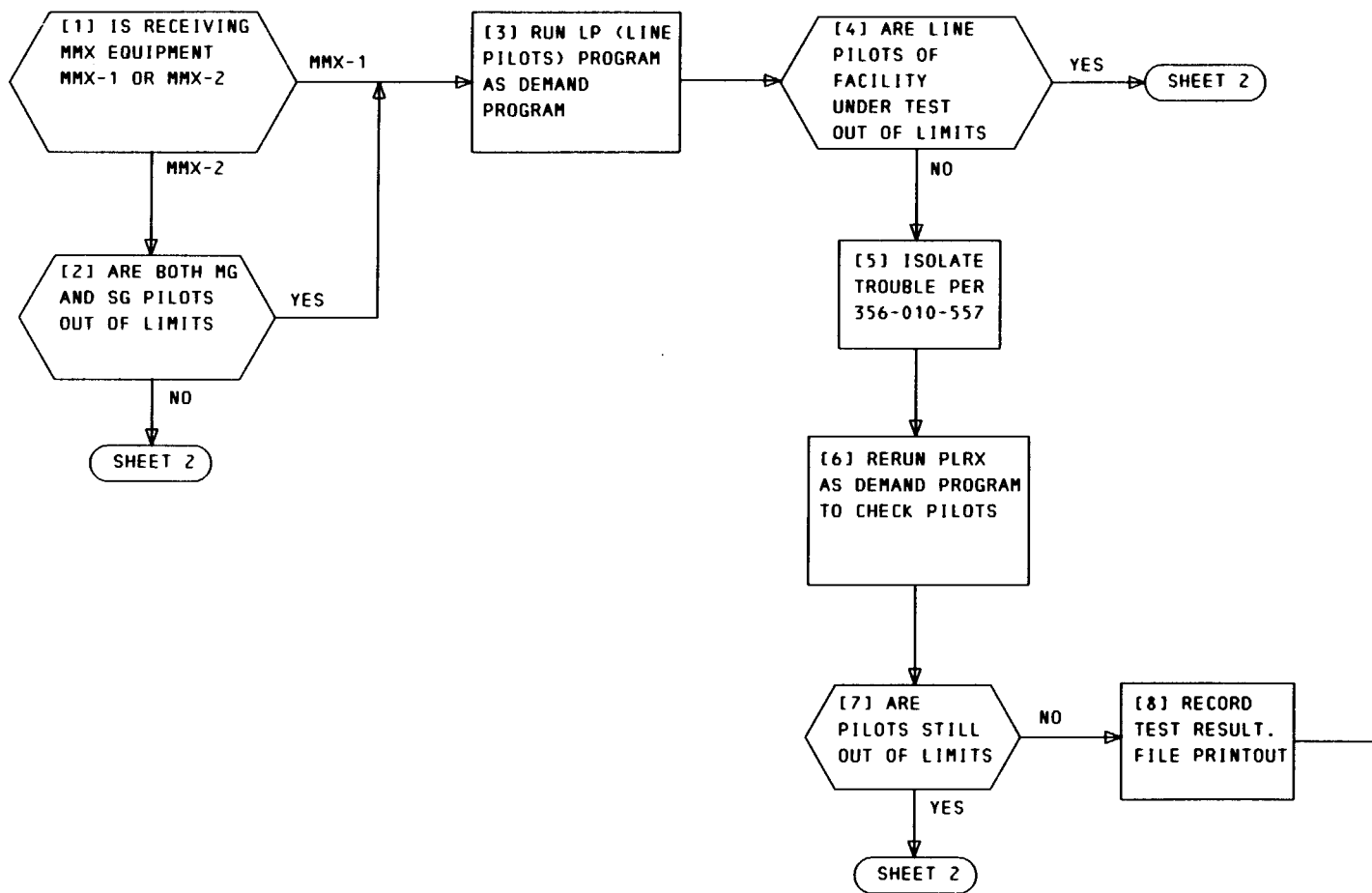

Chart 3—Correct Pilot Deviations of PLRX at Line Printout (Sheet 1 of 2)

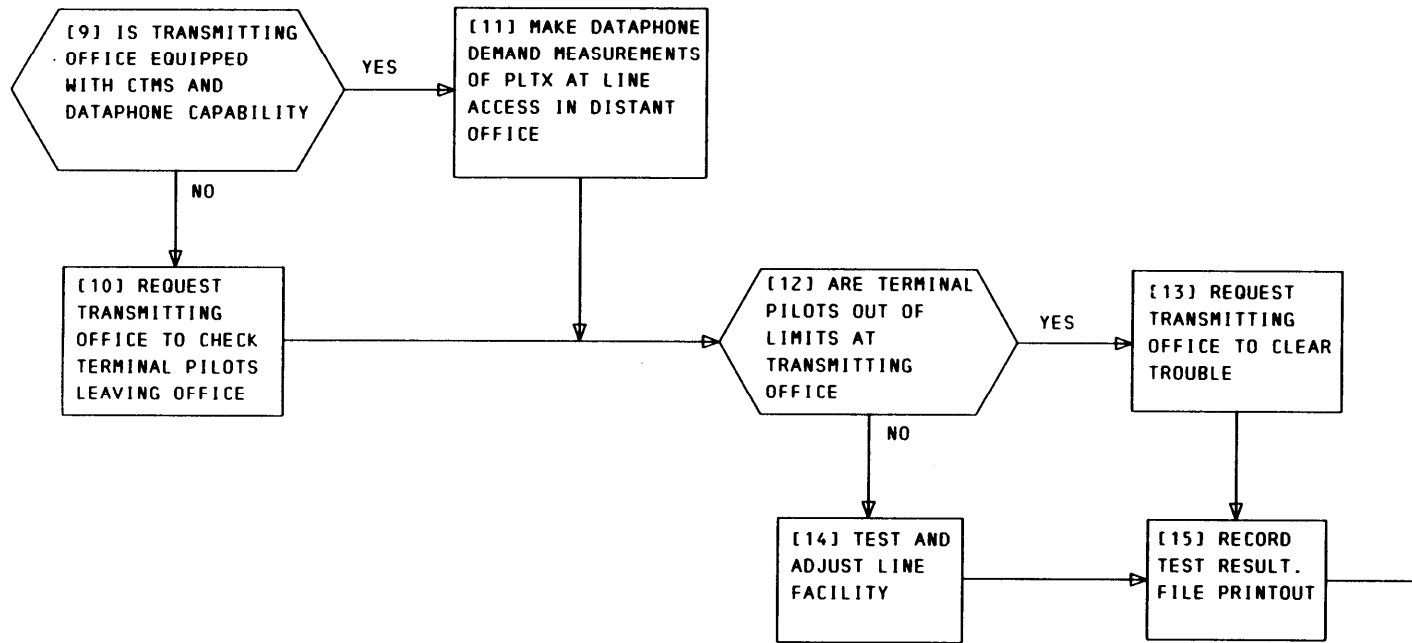

Chart 3—Correct Pilot Deviations of PLRX at Line Printout (Sheet 2 of 2)

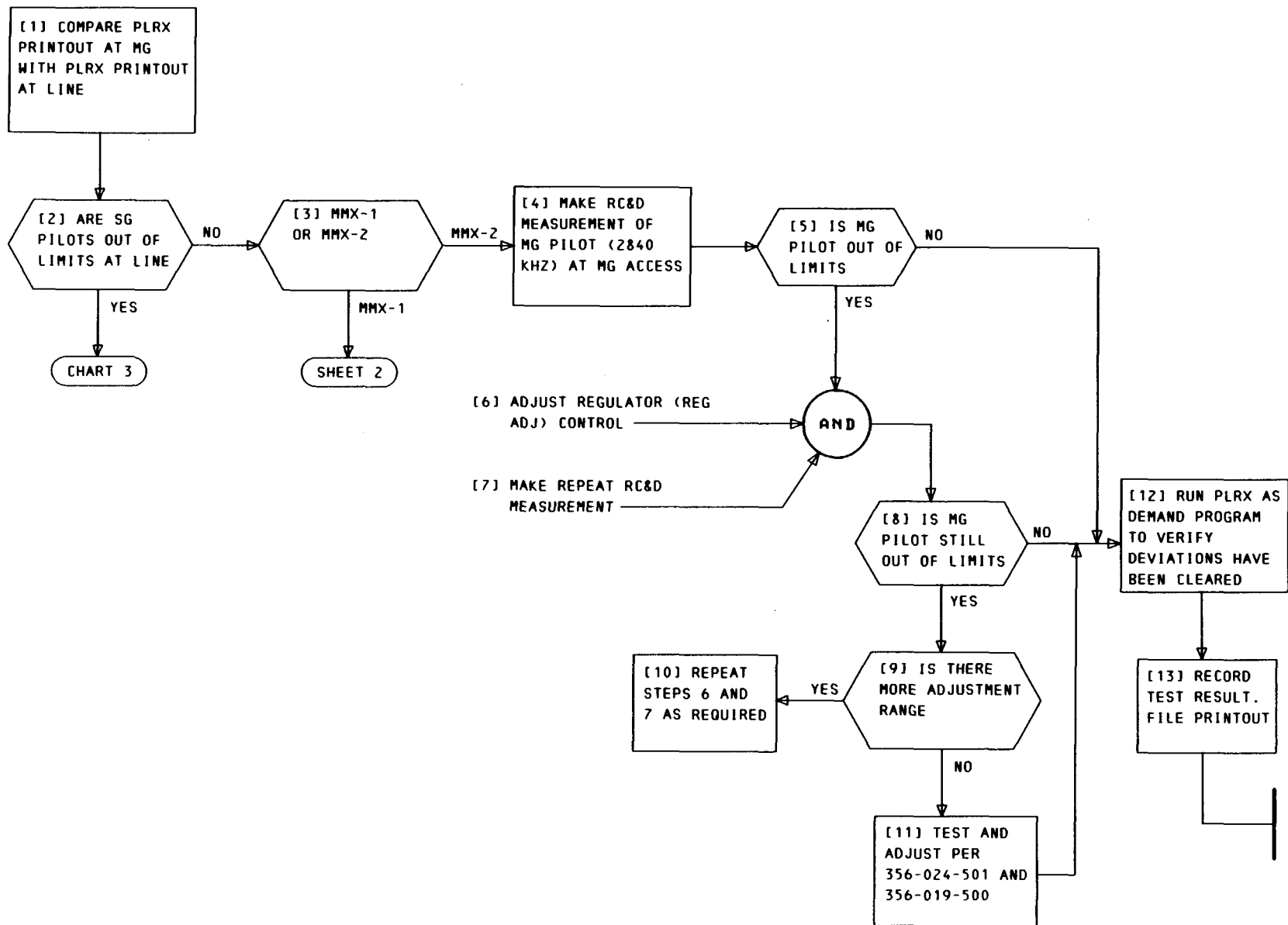

Chart 4—Correct Pilot Deviations of PLRX at Mastergroup Printout (Sheet 1 of 2)

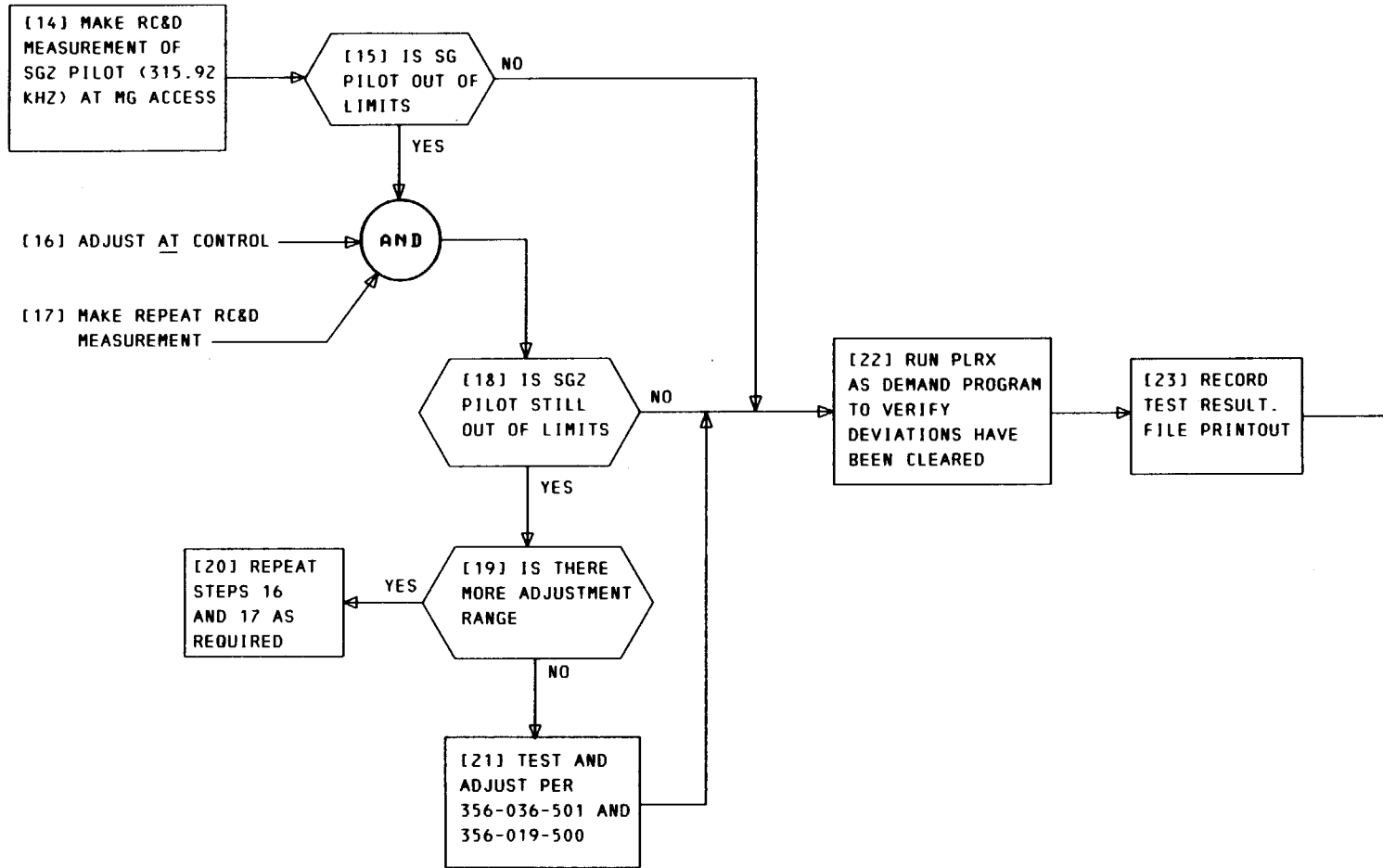

Chart 4—Correct Pilot Deviations of PLRX at Mastergroup Printout (Sheet 2 of 2)