

L MULTIPLEX TERMINALS
MMX-1
TRANSMITTING MASTERGROUPS
PATCHING PROCEDURES

This section provides patching procedures whereby regular equipment (transmitting mastergroups) is removed from or restored to service. Because of the numerous configurations applicable to the equipment involved, only typical transmitting mastergroup configurations are depicted by these procedures. Each office must determine its own equipment configuration and establish applicable patching procedures.

To prevent service interruptions while patching mastergroup equipment, effective monitoring procedures should be used. Three types of signals are available for monitoring purposes: test tone, conversation, and pilot. The most effective signal is a 1-kHz tone on a voice channel; however, local policy must establish monitoring and verification procedures to keep service interruptions to a minimum.

Transmission requirements must be met for the equipment involved before proceeding.

APPARATUS

Receiving Test Equipment (Section 356-010-500) capable of measuring the signal to be monitored at the correct power

Test Cords and Plugs as required

| STEP | PROCEDURE |
|------|--|
| | <p>Caution: <i>Since some patches may affect transmission levels, patching should be kept to a minimum. Before attempting any patches, read and understand the entire procedure.</i></p> <p>Note: To prevent service interruptions due to patching errors, the craftsman must have a thorough understanding of the following:</p> <ul style="list-style-type: none">(a) Transmission circuits involved(b) Local equipment and jack designations(c) Local policy regarding minimum monitoring requirements. |

| STEP | PROCEDURE |
|------|---|
| 1 | <p>Monitoring</p> <p>Select a voice-frequency channel working in the mastergroup bank to be patched; verify that the selected channel is not in service.</p> |
| 2 | <p>At the voice-frequency patch bay (VFPB), connect a 1-kHz test tone to the MOD IN jack of the selected channel [patch (1), Fig. 1].</p> <div data-bbox="214 553 1387 861" style="text-align: center;"> </div> |
| 3 | <p>Prepare the receiving test equipment (RTE) to measure the translated 1-kHz tone at the correct power for the monitoring point (Fig. 1).</p> <p>Note 1: See Section 359-080-501 for frequency charts and level diagrams.</p> <p>Note 2: Always monitor at a point in the circuit path beyond the final patch point.</p> |
| 4 | <p>At the HFPB, connect the RTE to the TRSG TERM OUT B jack [patch (2), Fig. 1]. Tune for the translated 1-kHz signal.</p> <p>Note: It may be necessary to remove the 1-kHz tone at the MOD IN jack to verify that the correct signal is being monitored.</p> |
| 5 | <p>Patching</p> <p>To remove regular equipment from service, proceed to Step 6.</p> <p>To restore regular equipment to service, proceed to Step 11.</p> |
| 6 | <p>Removing Regular Equipment From Service</p> <p>Locate the jacks (Fig. 2) associated with the regular and spare equipment to be patched.</p> |
| 7 | <p>At the transmitting patch panel (MG-HFPB), perform the following steps:</p> <p>(a) Remove the 358B (75-ohm termination) from the TRSG HYB IN MG() B jack [patch (1), Fig. 3].</p> <p>Note: Jack designations may vary between offices. The new designations (Table A) are used in this procedure.</p> |

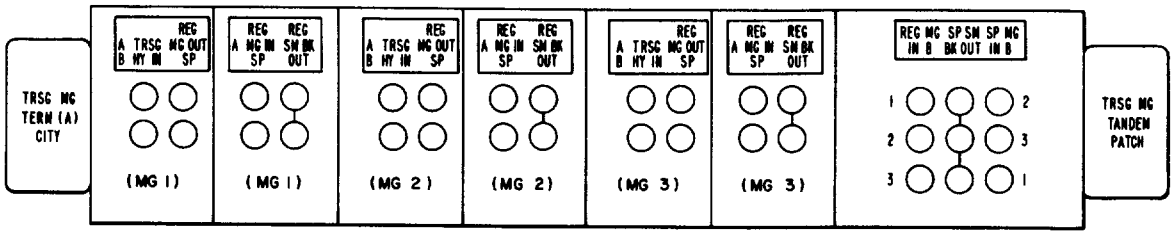
| STEP | PROCEDURE |
|------|--|
| | <div style="text-align: center;">  <p>Fig. 2—Transmitting Patch Jacks (MG-HFPB)</p> <p>(b) Insert a 372A plug (through connection) into the TRSG HYB IN MG() B and SP MG() OUT jacks [patch (2), Fig. 3].</p> <p>(c) Insert a 372A plug into the SP MG() IN A and multiple REG SM BK OUT jacks [patch (3), Fig. 3].</p> </div> |

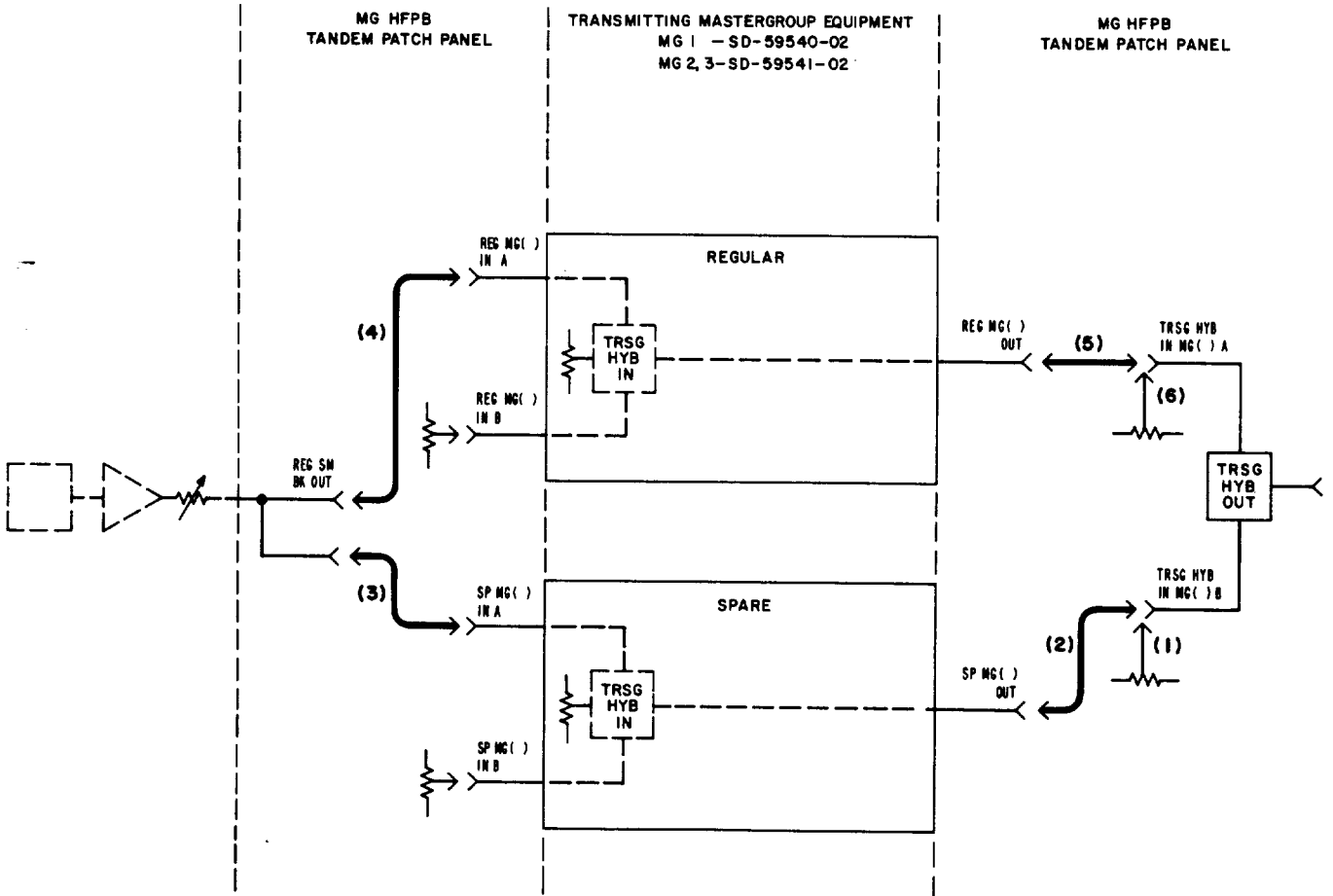

Fig. 3—Removing Regular Equipment From Service—Patching Procedure

| STEP | PROCEDURE |
|------|---|
| 8 | Observe the RTE indication. |
| | Requirement: Approximately a 3-dB increase in power |
| 9 | At the transmitting tandem patch panel (MG-HFPB), |
| | (a) Remove the 372A plug from the REG MG() IN A and multiple REG SM BK OUT jacks [patch (4), Fig. 3]. |
| | (b) Observe the RTE indication. |
| | Requirement: Normal power indication for the monitoring point |
| | (c) Remove the 372A plug from the TRSG HYB IN MG() A and REG MG() OUT jacks [patch (5), Fig. 3]. |
| | (d) Insert a 358B plug into the TRSG HYB IN MG() A jack [patch (6), Fig. 3]. |
| 10 | Disconnect the 1-kHz test tone and the RTE; where possible, identify all patches. |
| | Restoring Regular Equipment To Service |
| 11 | Locate the jacks (Fig. 2) associated with the regular and spare equipment to be patched. |
| 12 | At the transmitting tandem patch panel (MG-HFPB), perform the following steps: |
| | (a) Remove the 358B plug (75-ohm termination) from the TRSG HYB IN MG() A jack [patch (1), Fig. 4]. |
| | Note: Jack designations may vary between offices. The new designations (Table A) are used in this procedure. |
| | (b) Insert a 372A plug (through connection) into the TRSG HYB IN MG() A and REG MG() OUT jacks [patch (2), Fig. 4]. |
| | (c) Insert a 372A plug into the REG MG() IN A and multiple REG SM BK OUT jacks [patch (3), Fig. 4]. |
| 13 | Observe the RTE indication. |
| | Requirement: Approximately a 3-dB increase in power |
| 14 | At the transmitting tandem patch panel (MG-HFPB), |
| | (a) Remove the 372A plug from the SP MG() IN A and multiple REG SM BK OUT jacks [patch (4), Fig. 4]. |
| | (b) Observe the RTE indication. |

TABLE A

| OLD DESIGNATION | NEW DESIGNATION |
|---------------------------------|------------------------------|
| REG SM OUT | REG SM BK OUT |
| SP SM OUT | SP SM BK OUT |
| REG OR SP MG (1) IN LG A | REG OR SP MG () IN A |
| REG OR SP MG (1) IN LG B | REG OR SP MG () IN B |
| REG OR SP TRSG HYB IN MG 1 LG A | REG OR SP TRSG HYB IN MG 1 A |
| REG OR SP TRSG HYB IN MG 1 LG B | REG OR SP TRSG HYB IN MG 1 B |
| REG OR SP TRSG HYB IN MG 2 LG A | REG OR SP TRSG HYB IN MG 2 A |
| REG OR SP TRSG HYB IN MG 2 LG B | REG OR SP TRSG HYB IN MG 2 B |
| REG OR SP TRSG HYB IN MG 3 LG A | REG OR SP TRSG HYB IN MG 3 A |
| REG OR SP TRSG HYB IN MG 3 LG B | REG OR SP TRSG HYB IN MG 3 B |

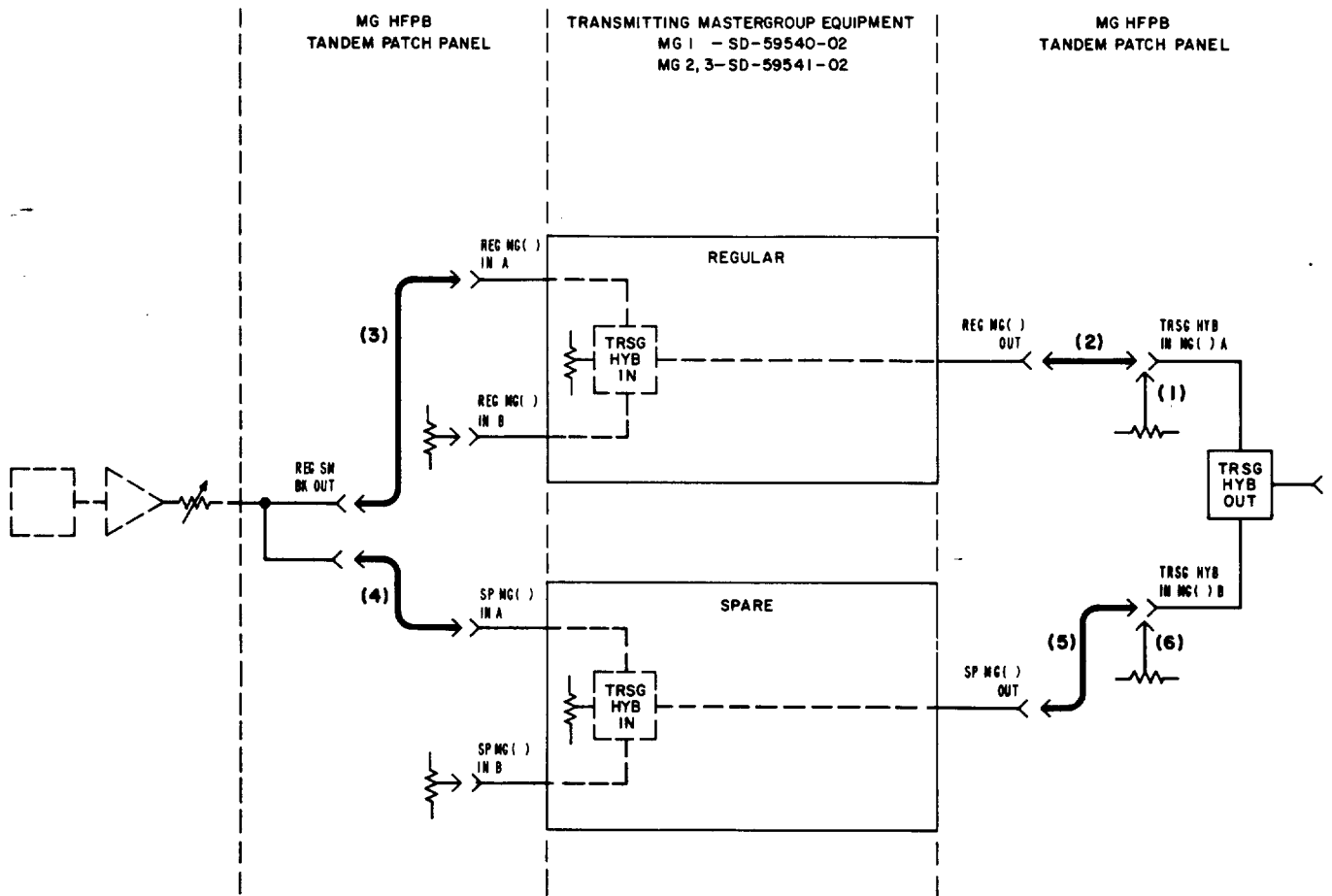

Fig. 4—Restoring Regular Equipment To Service—Patching Procedure

| STEP | PROCEDURE |
|------|--|
| 15 | <p>Requirement: Normal power indication for the monitoring point</p> <ul style="list-style-type: none">(c) Remove the 372A plug from the TRSG HYB IN MG() B and SP MG() OUT jacks [patch (5), Fig. 4].(d) Insert a 358B plug into the TRSG HYB IN MG() B jack [patch (6), Fig. 4]. <p>Disconnect the 1-kHz test tone and the RTE.</p> |