L MULTIPLEX TERMINALS
LMX-1
CARRIER AND PILOT SUPPLY
GROUP CARRIER DISTRIBUTING CIRCUIT
AMPLIFIER OUTPUT POWER

PURPOSE OF TEST

To measure and adjust, if necessary, the output power of the group carrier distribution amplifiers (Fig. 1).

REASON FOR ISSUE

This section is reissued to correct errors and improve the test procedures. Arrows are used to indicate significant changes. *Equipment Test Lists are not affected.*

SYNOPSIS

Each group carrier distributing circuit consists of two identical carrier filters, an ADJ equalization pad, two variable gain amplifiers, and either a resistive or capacitive distribution bus.

Outputs from the A and B 4-kHz harmonic generators are connected through the carrier generator transfer panel to the inputs of the carrier filters.

The filter having the highest output power is connected through an ADJ pad in order to equalize the two output signals. In the event of failure, automatic switching will select either the A or B harmonic generator input to the F1 or F2 filters, respectively.

The selected group carrier frequency is divided equally through a resistive hybrid and connected to two variable gain amplifiers. The outputs of both amplifiers are paralleled and connected to either a resistive or capacitive distribution bus for connection to group modulators or demodulators, pilot supply, and alarm circuit.

♦Tests are made at the BRDG jacks provided across the output of each group amplifier. The BRDG jacks are connected through protective resistors and provide a relative indication of the correct operation of the amplifier while it is connected to the distribution bus. Power requirements for all groups, when measured at the BRDG jacks, will be +0.2 dBm \pm 2.0 dB.♦

The group distribution bus is fed simultaneously by the A and B amplifiers. Inserting a plug into the OUT jack of one amplifier will reduce the power at the distribution bus approximately 2 dB.

NOTICE

Not for use or disclosure outside the
Bell System except under written agreement

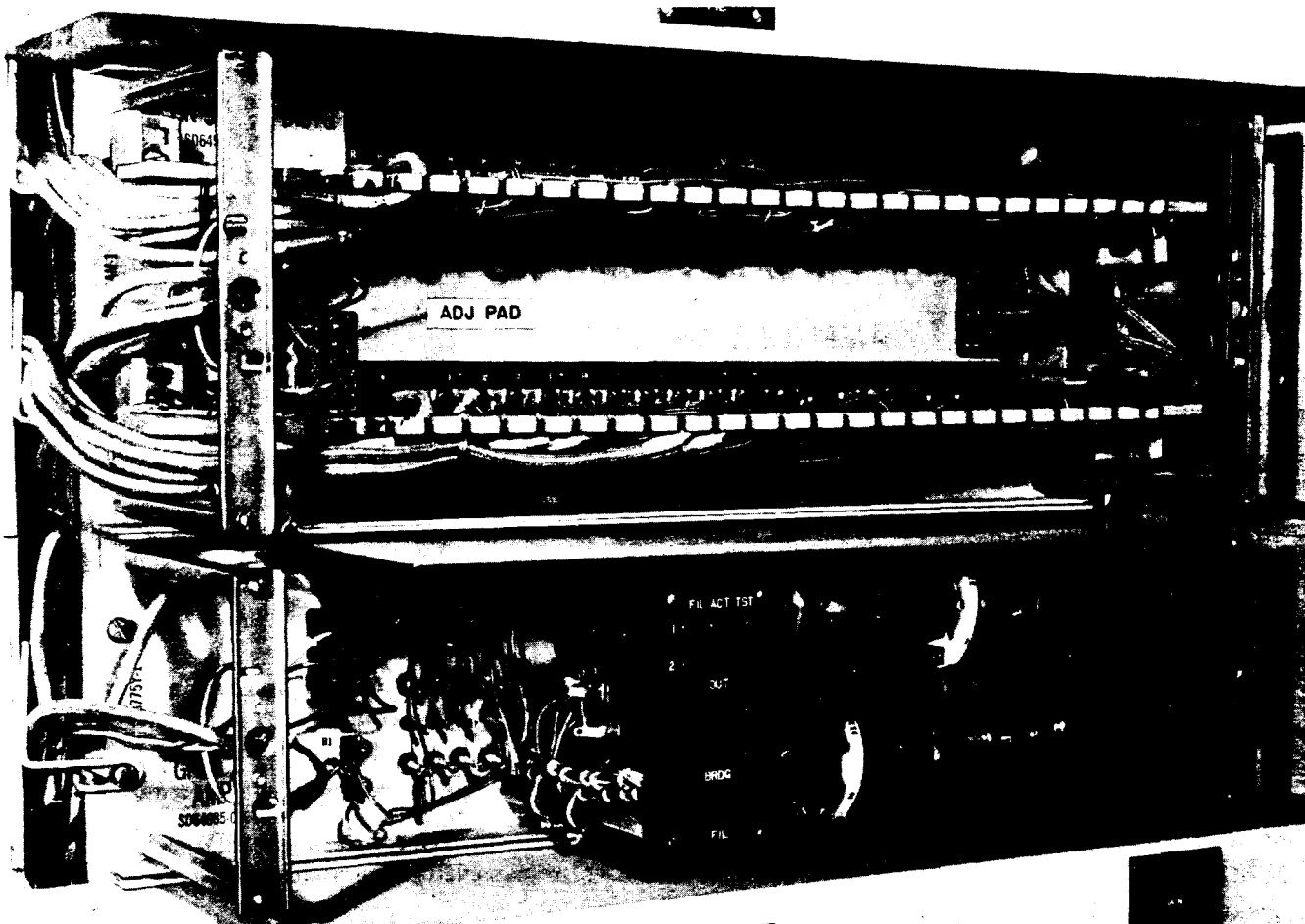

Fig. 1—Group Carrier Distribution Bus and Associated Distribution Amplifiers

CHART	PAGE
1—Power Measurement at BRDG Jacks	3
2—Power Measurement at OUT Jacks	5

APPARATUS

Receiving Test Equipment (Section 356-010-500) having the following input characteristics:

Frequency: 420 to 612 kHz

Power: 0 dBm (Chart 1); +21.0 dBm (Chart 2), both with suitable attenuation

APPARATUS:

Impedance: 135 ohms

3P20B CordSuitable **21-dB Attenuator** as required (Example: KS-1394 or Siemens 3D 112b).**CHART 1****POWER MEASUREMENT AT BRDG JACKS**

STEP	PROCEDURE
1	Prepare the receiving test equipment (RTE) for a 135-ohm measurement of the group carriers to be measured at 0.0 dBm (Table A).
2	Connect the RTE to the BRDG jack of the A amplifier [patch (1), Fig. 2].
3	Read the RTE meter. Requirement: +0.2 dBm \pm 2.0 dB for all groups
4	If the requirement of Step 3 is met, proceed to Step 5. If it is not met, perform the tests in Chart 2.
5	Remove [patch (1), Fig. 2] and connect the RTE to the BRDG jack of the B amplifier [patch (2), Fig. 2].

TABLE A
GROUP CARRIER AMPLIFIERS – OUTPUT
POWER AT BRDG JACKS

GROUP	FREQ (KHZ)	OUTPUT POWER (DBM)
1	420	+0.2 \pm 2.0 dB
2	468	+0.2 \pm 2.0 dB
3	516	+0.2 \pm 2.0 dB
4	564	+0.2 \pm 2.0 dB
5	612	+0.2 \pm 2.0 dB

CHART 1 (Cont)

STEP	PROCEDURE
------	-----------

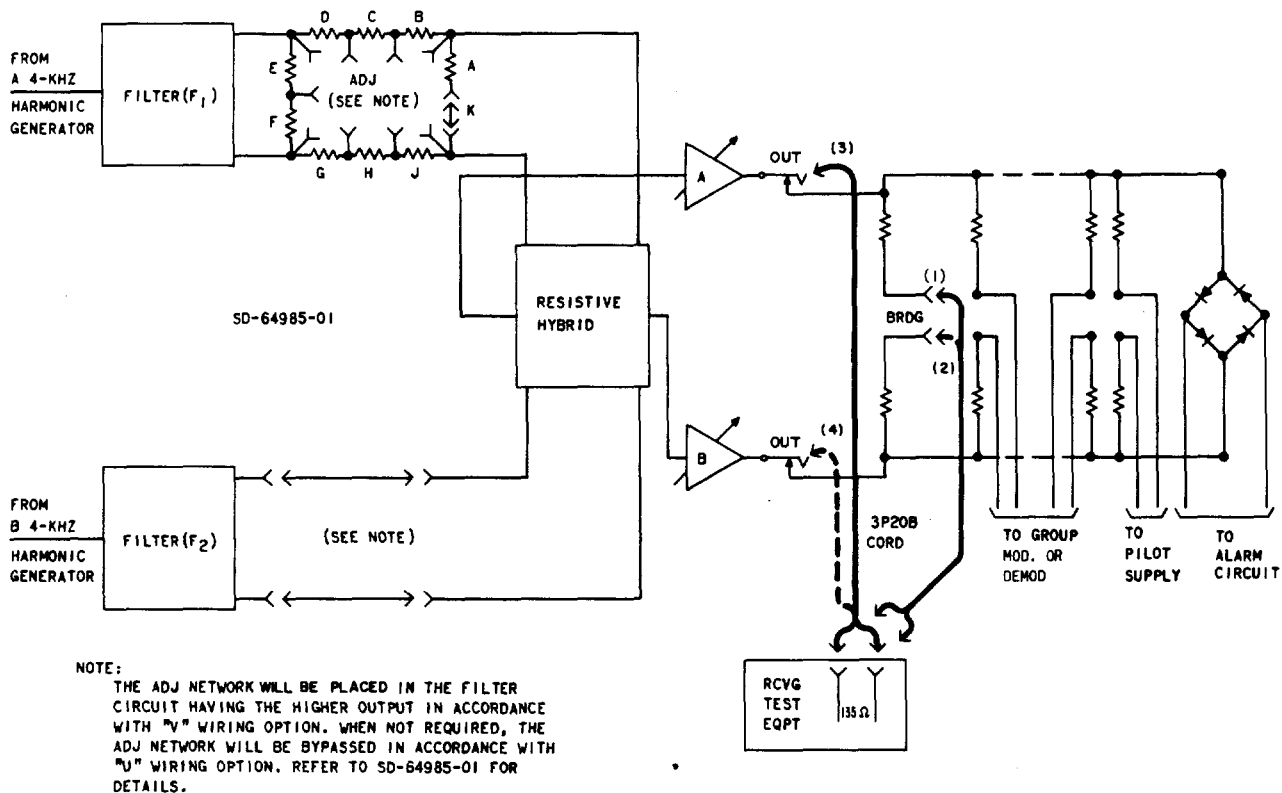

Fig. 2—Group Carrier Distributing Circuit—Measurement of Amplifier Output Power

6 Read the RTE meter.

Requirement: +0.2 dBm \pm 2.0 dB

7 If the requirement of Step 6 is met for all groups, remove [patch (2), Fig. 2] and proceed to Step 8. If it is not met, perform the tests in Chart 2.

8 At the carrier generator transfer panel, determine the working 4-kHz harmonic generator by depressing the TEST key. The working generator will be indicated by a lighted A or B panel lamp.

9 Manually transfer service to the standby 4-kHz harmonic generator as covered in Section 356-150-300.

 CHART 1 (Cont)

STEP	PROCEDURE
	Caution: <i>Transfer of the carrier supply will cause hits on data and telegraph service; therefore, the number of transfers should be limited to minimize service interruptions.</i>
10	Repeat Steps 1 through 6.
	Requirement: Indications should not differ from those obtained in Steps 3 and 6 by more than:
	(a) ± 0.5 dB for Groups 1, 4, and 5
	(b) ± 0.25 dB for Groups 2 and 3.
11	◆If requirements are not met, perform equalization tests in Section 356-154-501.◆
12	Remove [patch (2), Fig. 2].
13	At the carrier generator transfer panel, restore the transfer switch to NORM.

 CHART 2

 POWER MEASUREMENT AT OUT JACKS

- 1 Prepare the RTE for a 135-ohm measurement of the group carrier frequency to be measured at +21.0 dBm (Table B).
- 2 Connect the RTE to the OUT jack of the A group amplifier [patch (3), Fig. 2].
- 3 Read the RTE meter.
- Requirement:** See Table B.
- 4 If the requirement of Step 3 is not met, check the filter circuit input (Section 356-152-501) and then adjust the amplifier GAIN control to meet the requirement.
- 5 Remove [patch (3), Fig. 2] and connect the RTE to the OUT jack of the B group amplifier [patch (4), Fig. 2].
- 6 Read the RTE meter.
- Requirement:** See Table B.
- 7 If the requirement of Step 6 is not met, adjust the amplifier GAIN control to meet the requirement. Remove [patch (4), Fig. 2].

CHART 2 (Cont)

STEP	PROCEDURE
------	-----------

TABLE B
GROUP CARRIER AMPLIFIERS – OUTPUT
POWER AT OUT JACKS

GROUP	FREQ (KHZ)	OUTPUT POWER (DBM)	
		CAPACITIVE BUS	RESISTIVE BUS
1	420	+21.4 ±1.0	+21.4 ±1.0
2	468	+21.4 ±0.6	+21.4 ±0.25
3	516	+21.4 ±0.6	+21.4 ±0.25
4	564	+21.4 ±1.0	+21.4 ±1.0
5	612	+21.4 ±1.0	+21.4 ±1.0

8 At the carrier generator transfer panel, determine the working 4-kHz harmonic generator by depressing the TEST key. The working generator will be indicated by a lighted A or B panel lamp.

9 Manually transfer service to the standby 4-kHz harmonic generator per Section 356-150-300.

Caution: *Transfer of the carrier supply will cause hits on data and telegraph service; therefore, the number of transfers should be limited to minimize service interruptions.*

10 Repeat Steps 1 through 7.

Requirement: Indications should not differ from those obtained in Steps 3 and 6 by more than:

- (a) ±0.5 dB for Groups 1, 4, and 5
- (b) ±0.25 dB for Groups 2 and 3.

11 If the requirements of Step 10 are met, proceed to Step 12. If they are not met, perform equalization tests in Section 356-154-501.

12 Remove [patch (4), Fig. 2].

13 At the carrier generator transfer panel, restore the transfer switch to NORM.